



Politecnico di Bari

Repository Istituzionale dei Prodotti della Ricerca del Politecnico di Bari

Novel, cost-effective configurations of combined power plants for small-scale cogeneration from biomass: Design of the immersed particle heat exchanger

This is a pre-print of the following article

Original Citation:

Novel, cost-effective configurations of combined power plants for small-scale cogeneration from biomass: Design of the immersed particle heat exchanger / Amirante, R.; Distaso, E.; Tamburrano, P.. - In: ENERGY CONVERSION AND MANAGEMENT. - ISSN 0196-8904. - 148:(2017), pp. 876-894. [10.1016/j.enconman.2017.06.047]

Availability:

This version is available at <http://hdl.handle.net/11589/111523> since: 2021-03-12

Published version

DOI:10.1016/j.enconman.2017.06.047

Publisher:

Terms of use:

(Article begins on next page)

Novel, cost-effective configurations of combined power plants for small-scale cogeneration from biomass: design of the Immersed Particle Heat Exchanger

Riccardo Amirante, Elia Distaso and Paolo Tamburrano

Department of Mechanics, Mathematics and Management (DMMM),
Polytechnic University of Bari, Italy

Abstract

This paper aims at proposing a general procedure for the preliminary design of the Immersed particle heat exchanger, which is a novel high temperature gas to gas heat exchanger using ceramic particles as solid intermediate medium for the purpose of transferring heat between two gases in high temperatures applications where negligible pressure drops are needed. This work gives an insight into the application of this heat exchanger to a novel, small scale, externally fired combined cycle, providing details regarding its architecture and characteristics as well as novel solutions that can reduce the capital costs of the heat exchanger while increasing its efficiency. Analytical models are developed for the design of the systems necessary to move the particles within the heat exchanger and for the evaluation of the associated energy losses. In addition, an optimization design procedure is developed in order to correctly select the main geometric parameters of the heat exchanger with application to a generic externally fired combined cycle. The procedure is finally tested on a specific case, in which specific thermodynamic values of the externally fired combined cycle were considered. The results show that the project is highly viable, as the dimensions of the heat exchanger are compact with both the pressure and energy losses being negligible.

Keywords: biomass; combined cycle; gas to gas heat exchanger

NOMENCLATURE

c_p	<i>Specific heat at constant pressure</i>	$[J/(kg\ K)]$
D_{top}	<i>Diameter of the top column</i>	$[m]$
D_{bot}	<i>Diameter of the bottom column</i>	$[m]$
D_r	<i>Rotor diameter</i>	$[m]$
G_a	<i>Air mass flow rate</i>	$[kg/s]$
$G_{a,lost}$	<i>Total loss of compressed air</i>	$[kg/s]$
$G_{a,lost,1}$	<i>Loss of compressed air (first contribution)</i>	$[kg/s]$
$G_{a,lost,2}$	<i>Loss of compressed air (second contribution)</i>	$[kg/s]$
$G_{a,lost,3}$	<i>Loss of compressed air (third contribution)</i>	$[kg/s]$
G_b	<i>Fuel mass flow rate</i>	$[kg/s]$
G_p	<i>Particle mass flow rate</i>	$[kg/s]$
G_s	<i>Steam mass flow rate</i>	$[kg/s]$
H_{top}	<i>Height of the top column</i>	$[m]$

H_{bot}	<i>Height of the bottom column</i>	<i>[m]</i>
i	<i>Enthalpy</i>	<i>[J/kg]</i>
h	<i>Blade height</i>	<i>[m]</i>
n_{mod}	<i>Number of IPHE modules</i>	
p	<i>Static pressure</i>	<i>[Pa]</i>
S_{tot}	<i>Overall heat exchange surface</i>	<i>[m²]</i>
T	<i>Temperature</i>	<i>[K]</i>
V	<i>Volume of the particles discharged per revolution</i>	<i>[m³]</i>
W	<i>Blade width</i>	<i>[m]</i>

Greek

ϵ_{tol}	<i>Tolerance</i>
ξ	<i>Coefficient accounting for blade thickness</i>
λ	<i>Thermal conductivity</i>
λ_v	<i>Filling coefficient</i>
η_{conv}	<i>Efficiency of the pneumatic conveyor</i>
η_{IPHE}	<i>Efficiency of the IPHE</i>

Subscripts

1	<i>Compressor inlet</i>
2	<i>Compressor outlet</i>
2'	<i>Inlet of the bottom column</i>
3	<i>Turbine inlet</i>
5	<i>Inlet of the top column</i>
6	<i>Outlet of the top column</i>
bot	<i>Bottom of the IPHE</i>
top	<i>Top of the IPHE</i>
p	<i>Particles</i>
press	<i>Pressurization system</i>
sim	<i>Simulation</i>

Acronyms

<i>CHP</i>	<i>Combined heat and power</i>
<i>EFGT</i>	<i>Externally fired gas turbines</i>
<i>HRS</i>	<i>Heat recovery steam generator</i>

<i>HTHE</i>	<i>High temperature heat exchanger</i>
<i>IPHE</i>	<i>Immersed particle heat exchanger</i>
<i>ORC</i>	<i>Organic Rankine Cycle</i>
<i>PHS</i>	<i>Particle handling systems</i>
<i>RPM</i>	<i>Revolutions per minute</i>

25

26

1. Introduction

27

28

29

30

31

32

33

34

35

36

37

38

39

40

41

42

43

44

45

46

47

48

49

50

51

52

53

As established by the recent 2015 United Nations Climate Change Conference held in Paris, COP 21, all nations have to promote the employment of renewable technologies in order to reduce the quantity of CO₂ released into the environment. The declared target is to limit the temperature increase to 2 °C compared to pre-industrial levels [1]. To reach this goal, it is very important to develop novel and effective technologies capable of boosting the exploitation of renewable sources [2]. Among these, biomass is the most continuous source of energy [3]; biomass can be used either directly as solid fuel feeding power plants or indirectly after conversion into a secondary form of energy (e.g. syngas and biogas) by using air, oxygen and/or steam [4]. In spite of the several advances achieved in biomass gasification systems [5], the direct use of biomass needs further developments in relation to the state of the art. Over the past years, the industrial and university research has been focused on the development and improvement in ORC power plants, which are, at the state of the art, the most widespread and profitable technology applicable to burning biomass for small scale cogeneration (production of heat and power) [6]. Different ORC configurations were studied in [7] to exploit high temperature waste heat; in contrast, the application of ORC to low grade waste heat recovery was thoroughly investigated in [8]. The effects of the thermodynamic parameters on the ORC performance were examined in detail in [9] along with the effects of different working fluids. It results that the maximum values of electrical efficiency attained by small-scale biomass-fired Organic Rankine Cycle (ORC) systems (the leader technology for CHP generation from biomass) are lower than 20%, with the efficiency decreasing with the decreasing size of the plant [10].

The main problem regarding ORC power plants is the need for organic fluids, which usually have a global warming potential greater than zero and are usually toxic and inflammable. For these reasons, rather than focusing on the improvement in the ORC technology, the authors of this paper have been concentrating all their efforts on a different strategy, which aims at proposing a concrete alternative to ORC plants. The proposed alternative is a small-scale combined cycle employing a topping externally fired turbogas cycle followed by a bottoming steam cycle, which is capable of producing useful heat and power from solid biomass. This power plant, which was proposed in [11], has the advantage of using a natural fluid (water) instead of an organic molecule. Furthermore, the main idea is to feed this power plant with carbon neutral biomass and to position the plant on site (where the biomass is produced), thus avoiding the amount of CO₂

54 released into the environment because of fuel transportation (an example of carbon neutral biomass is
55 represented by pruning residues, which are usually unemployed in spite of their large availability, especially
56 in the Mediterranean regions [12]). These characteristics make the proposed power plant fully sustainable;
57 in addition, the feasibility in terms of efficiency was addressed in the previous paper [11], which
58 demonstrated that the presented combined cycle has the potential to achieve a high level of electrical
59 efficiency (up to 25%), while being cost-effective. That analysis was performed for a very low size of the plant,
60 namely for a produced electrical power of 100 kW_e. For such an electrical power produced from biomass, the
61 electrical efficiency of stand-alone ORC cycles is usually well below 20% [11].

62 The realization of the proposed combined cycle is made possible by the external combustion configuration,
63 in which the core is a gas to gas heat exchanger capable of coupling the turbogas with the external combustor
64 (to be fed with carbon neutral biomass). With regard to externally fired and/or closed cycle gas turbine
65 configurations, the studies present in the scientific literature mainly deal with the optimization of the
66 thermodynamic parameters of the proposed solutions [13]. As an example, in [14] the optimal
67 thermodynamic parameters were found for a plant with a power generation capacity of 1 MW and
68 incorporating a biomass gasifier using paper as fuel. As a further example, in [15] the coupling between an
69 103 externally fired gas turbine and a solar collector was investigated in detail.

70 However, the realization of an externally fired gas turbine (and hence externally fired combined cycle) is only
71 allowed by the presence of the gas to gas heat exchanger, and the scientific literature has not highlighted
72 effective gas to gas heat exchangers that are also capable of withstanding very high temperatures [16]. This
73 is due to the fact that the design of the gas to gas heat exchanger is not a trivial task, since it must ensure
74 low pressure drops while being capable of withstanding the high temperatures developed by a turbogas
75 cycle. Furthermore, it must be compact and able to guarantee a continuous operation mode. Unfortunately,
76 all these characteristics are very difficult for a gas to gas heat exchanger to obtain at the same time. Technical
77 solutions provided to date mainly refer to low temperature applications, namely, to the design of
78 recuperators for small- and microturbines, where the employed low pressure ratios make the heat recovery
79 mandatory. A variety of gas-to-gas recuperators were discussed in [17], in which plate, plate fin, printed
80 circuit, and spiral and tubular heat exchangers were compared, confirming that the only way to reach very
81 high temperatures is to use an intermediate thermal medium, made of ceramic material, first to recover and
82 then to release heat from a high temperature flow to another one. In another study, a wide range of heat
83 exchanger concepts and demonstrators were compared [18], confirming the highest potential of ceramic
84 recuperators over the other ones. The main problem is that currently available ceramic heat exchangers have
85 either a non-continuous operation mode or produce too high pressure drops. Two innovative concepts for
86 microturbine applications were proposed recently: a ceramic honeycomb regenerator disk [18] and the novel
87 "Swiss-Roll" [19]. In the former, the ceramic honeycomb is the thermal vector able to absorb heat from the

88 hot flow and to release it to the cold flow, passing alternatively into a rotating structure. The latter is made
89 up of “two flat plates that are wrapped around each other, creating two concentric channels of rectangular
90 cross-section” [19]: the theoretical efficiency of this heat exchanger is 85%, but with a pressure drop of 10%.
91 A similar architecture, developed by Zimmermann et al. [20], is composed of two ceramic tanks that are
92 periodically switched to allow the heat exchange between hot and cold gases. This configuration has the
93 drawback of being discontinuous.

94 Because of the typical drawbacks caused by the employment of ceramic materials (high pressure drops and
95 discontinuous operation), some studies are investigating on valid alternatives to ceramic materials, such as
96 new alloys capable of withstanding very high temperatures and pressures [21].

97 In this scenario, because of the lack of available gas to gas heat exchangers capable of both withstanding high
98 temperatures and producing negligible pressure drops as well as working continuously, two configurations
99 for the gas to gas heat exchanger were proposed by the authors in the previous paper, with the first one
100 being based on a conventional tube and shell configuration made of a highly-resistant metallic alloy, such as
101 a nickel alloy. This solution has a limitation regarding the maximum temperature reachable at the inlet of the
102 gas turbine, which results in a limitation in the maximum cycle efficiency. For this reason, another solution
103 was also proposed for the gas to gas heat exchanger, named the immersed particle heat exchanged (IPHE).
104 The IPHE employs ceramic particles as an intermediate solid medium with high thermal capacity: the particles
105 fall in a column where the combustion gases flow from the bottom to the top; the warmed up particles are
106 then collected at the bottom of the column and inserted into the top of a second column where they transfer
107 the accumulated heat to the counterflowing cold gas, namely the compressed air coming from the
108 compressor. By virtue of its unique characteristics (it does not make use of metallic surfaces for the heat
109 exchange and is composed of large vertical ducts which make the pressure drops negligible), the IPHE has
110 the potential to overcome the unresolved problems regarding gas to gas heat exchangers, namely the
111 achievement of high temperatures and low pressure drops at the same time, while guaranteeing a
112 continuous operation mode.

113 The previous paper [11] was based on the thermodynamic analysis of the small scale combined cycle;
114 however, the design and application of the innovative heat exchanger to the combined cycle was not
115 performed. This paper is the second part of the previous paper [11] in that gives an insight into the IPHE,
116 providing more details regarding its architecture and characteristics, in addition to proposing a general
117 approach for the design of its main components in the case of application to small scale externally fired
118 combined cycles. The main objective is to find out the main dimensions (height and diameters of the heat
119 exchanger) necessary for the heat exchange and evaluate the feasibility in terms of bulkiness and energy
120 losses when the IPHE is applied to a specific case of study.

121

122

123

124

2. Materials and methods

125

126

127

128

129

130

131

132

133

134

135

136

137

138

139

140

141

142

143

144

145

146

147

148

149

150

151

152

153

154

155

This section shows the application of the IPHE to the combined cycle presented in [11], providing all the necessary details about the architecture of the IPHE. Fundamental systems serving the purpose of moving the particles inside the heat exchanger are conceived, and analytical models are developed to design these systems and study the associated energy losses. The architecture and analytical model of the heat exchange columns, which are the core of the heat exchanger, are also presented and discussed. An optimization process design is finally developed that is based on the coupling among the analytical models, a genetic algorithm and a CFD analysis of the heat exchange between the particles and the gas within both columns.

2.1 Application of the immersed particle heat exchanged to small scale combined cycles externally fired with biomass

Figure 1 shows the proposal of application to the combined cycle. The latter must be externally fired, with the input thermal power being given by the combustion of carbon neutral biomass, such as pruning residues [12]; the output mechanical power is given by both the gas turbine of the topping cycle and the steam turbine of the bottoming cycle. The air, suctioned by the external environment, is compressed by a centrifugal compressor and delivered into the high temperature gas to gas heat exchanger (HTHE), where it undergoes a great temperature increase. The air exiting the HTHE can expand through the gas turbine, which transforms the air enthalpy into mechanical work. After the expansion is concluded, the air discharged from the turbine is delivered into the combustion chamber, in which the combustion between the biomass and the oxygen present in the air takes place. The produced hot gases are conveyed firstly into a cleaning system (represented by an insulated cyclone separator) and then into the HTHE to transfer their heat to the compressed air (the latter is going to enter the turbine) without mixing with each other. After the heat exchange is concluded, the cooled down flue gases, rather than being exhausted into the atmosphere, are delivered to the heat recovery steam generator (HRSG) in order to generate superheated steam, which can expand through a small steam turbine. The steam can be expanded down to 1 bar (or similar pressure levels), rather than being expanded to lower pressures, in order to allow high temperature heat recovery (100 °C) from its condensation. In this way, the power plant is capable of producing useful thermal power in addition to electric power, thus achieving a combined heat and power configuration (CHP). Summarizing, the proposed architecture of combined cycles presents the following innovative aspects:

- The external combustor combined with the HTHE allows adapting gas turbine plants to dirty fuels: unlike internal combustion gas turbines (where the combustion gases enter the turbine), the combustion gases do not expand through the turbine, which is prevented from being damaged by metal and solid compounds generated by the combustion of dirty fuels, such as solid biomass.

- 156 • Different solutions can be adopted for the compressor-turbine group of the topping cycle. In fact, the
 157 compressor-turbine group can be taken from the automotive industry (since in several models the turbine
 158 blades are made of Nickel alloy and can withstand high temperatures, up to 1150 K) and coupled with a
 159 lower temperature power turbine (easy to manufacture). Alternatively, either an automotive compressor-
 160 turbine group can be adapted to be connected to an electric generator or a compressor-turbine-generator
 161 assembly can be manufactured ex-novo.
- 162 • The bottoming part of the power plant is a typical steam cycle, but with the particularity of having its
 163 components downsized in comparison with typical steam cycles employed for energy generation. The
 164 commercially available “Green steam turbine” is proposed to be used as the micro-turbine of the
 165 bottoming cycle [11]; it is a cheap model that is capable of generating a maximum electrical power of
 166 about 15 kWe, with a maximum pressure of 10 bar and a maximum temperature of 225 °C. Using the data
 167 provided by the manufacturer, the isentropic efficiency can be estimated to be equal to about 50%, which
 168 is the highest value among commercially available micro-steam expanders.

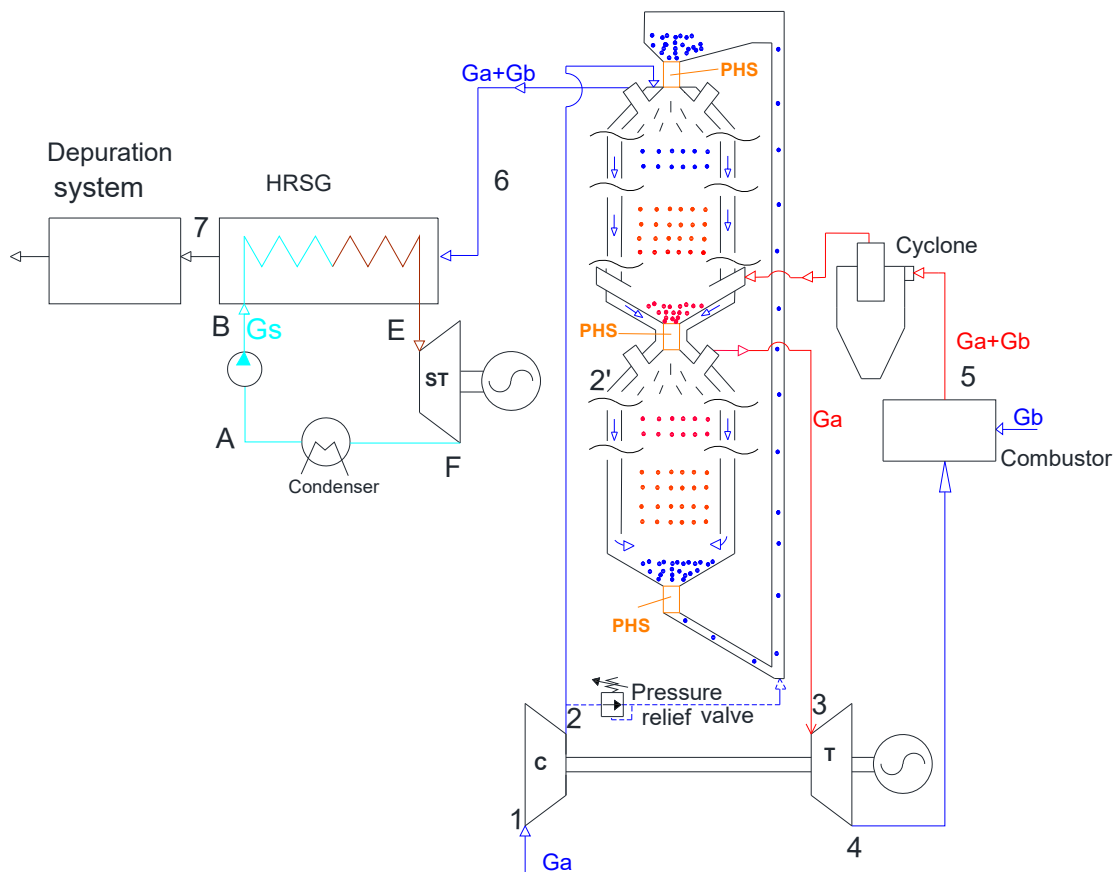

169
 170 *Fig.2. Application of the IPHE to small scale combined cycles (PHS= particle handling systems, HRSG=heat*
 171 *recovery steam generator, G_a = air mass flow rate, G_b = fuel mass flow rate, G_s =steam mass flow rate)*
 172

173 The IPHE serves as the HTHE and can be composed of either one or more modules, depending on the values
174 of the mass flow rates. As shown in Fig. 1, each module is composed of two heat exchange columns: the
175 upper one has the function of heating up small ceramic particles falling from its top down to its bottom, in
176 counter-flow with the hot gases coming from the external combustor. The gases rise from the bottom of the
177 upper column up to its top; afterwards, they leave the IPHE and enter the HRSG. Simultaneously, the warmed
178 up particles exiting the upper column are collected, pressurized and transferred into the lower column;
179 during their fall within the bottom column, they transfer heat to the compressed air coming from the
180 compressor, increasing its temperature up to the level required by the gas turbine. In order to guarantee a
181 continuous operation mode, the particles must be delivered back from the bottom to the top of the plant.
182 This task is performed by a pneumatic conveyor, which uses a very small part of the compressed air to lift
183 the particles up to the top of the heat exchanger. The pressure needed to lift the particles can be adjusted
184 by using a pressure relief valve, as shown in Fig. 1.

185 Because of the pressure difference existing between the two columns (the upper one is almost at ambient
186 pressure, whereas the lower one is at the same pressure as that generated by the compressor), three particle
187 handling systems are introduced and designed in this work in order to effectively transfer the particles
188 between the two columns. The upper handling system allows transferring the particles coming from the
189 pneumatic conveyor into the upper column, the central system serves as a particle pressurization system
190 needed to transfer the particles from the lower pressure environment into the higher-pressure one, whereas
191 the lower system allows the particles to be moved from the lower column into the pneumatic conveyor. As
192 shown in Fig. 1, each particle handling system is preceded by an accumulation reservoir, in order to enable
193 the variation in the particle flow rate, thus giving high flexibility to the whole system.

194 Initially, the IPHE was thought to be employed in medium and large-scale power plants employing dirty fuels
195 such as coal [22]; however, a more sustainable project is its application to small-scale power plants capable
196 of burning biomass on site to produce useful heat power in addition to the electrical power. Furthermore, in
197 the initial solution proposed for the IPHE [23], both columns were proposed to be realized in ceramic
198 material, which can withstand the high temperatures present in a Joule Brayton cycle. However, this choice
199 could lead to high investment costs and difficulties manufacturing the project idea. To overcome this issue,
200 a new solution is developed in this paper: it consists in manufacturing every part of the IPHE out of steel,
201 whose thermo-mechanical resistance can be ensured by cooling the walls. This can be achieved by letting the
202 compressed air flow through the path shown in Fig. 1 before entering the lower column: in such a way, the
203 compressed air can flow through the external channels surrounding the most critical parts of the IPHE (walls
204 of the columns as well as pressurization system), thus taking heat away from the walls of the IPHE. A similar
205 strategy is used in both heavy duty and aero derivative gas turbines, in which a part of the compressed air

206 (referred to as secondary air) is used to cool the combustor liner and prevent the metals of the combustor
207 from being damaged.

208 2.2 Architecture and analytical model proposed for the particle handling systems

209 As mentioned before, because of the different pressure levels existing between the two columns, adequate
210 systems must be designed to move the particles within the IPHE. The authors dealt with this task also in
211 previous papers [22]; the previous work has allowed conceiving the solution presented in this paper. Fig. 2
212 shows the solution proposed for the three particle handling systems: each of them is made up of a convergent
213 reservoir, a guillotine valve and a rotary valve. With regard to the latter, it is a component widely used in
214 several industrial fields, allowing particles and loose material to be moved from two environments at
215 different pressures. It is mainly composed of a gear rotor rotating within a cover interposed between two
216 environments at different pressure. A few commercially available solutions have been recently proposed to
217 avoid the interference occurring among the particles, the moving parts and the stator. One of these employs
218 helical profiles for the blades of the rotor, another employs particular shapes for the inlet section; either one
219 could be used in the present case, thus avoiding interference problems noticed in previous studies [23].
220 The application of these systems to the IPHE can be made possible by using a reservoir to be placed
221 downstream of the rotary valve, in addition to a guillotine valve to be interposed between the rotary valve
222 and the reservoir. In this way, the adjustment of the opening degree of the guillotine valve can allow the
223 quantity of particles entering the rotary valve to be regulated properly, thus avoiding particle accumulation
224 at the inlet of the rotary valve, which could result in interference issues. With this system, the particle flow
225 rate injected into the columns can be adjusted by acting on the rotational speed of the rotors, while the
226 opening degree of the guillotine valves can be changed to ensure the highest possible filling within the rotor
227 chambers while avoiding particle interference.

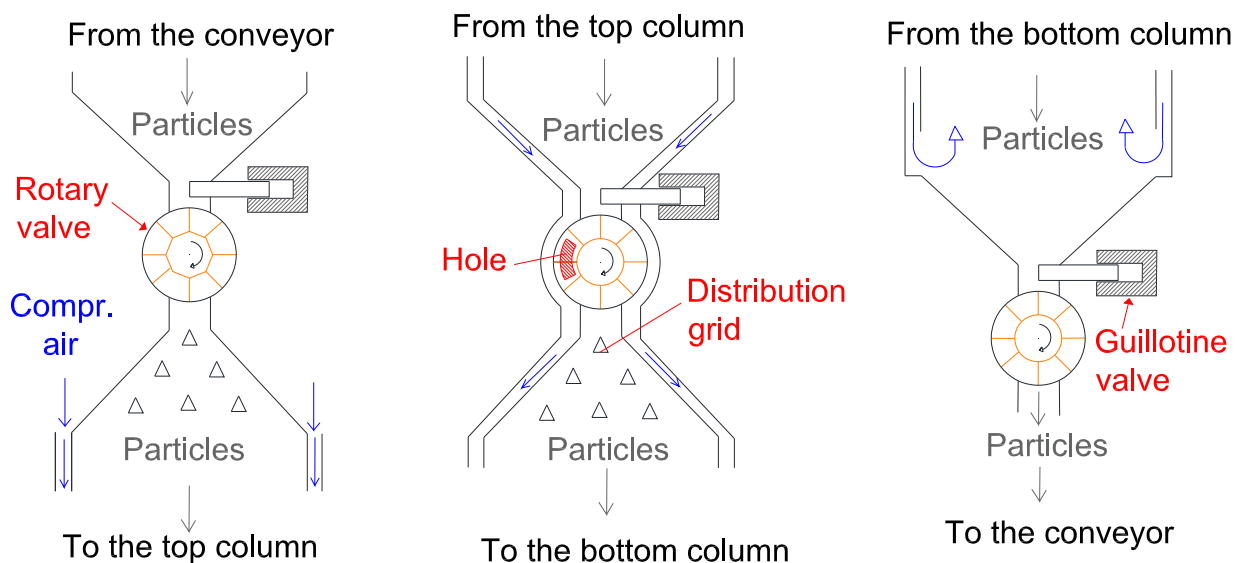

229 *Fig.2. Configuration proposed for the particle handling systems (left: upper system, centre: pressurization*
230 *system; right: lower system)*

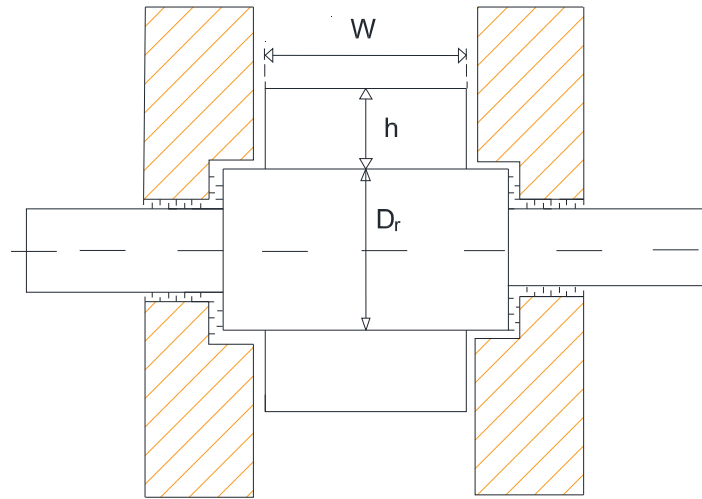

231
232 *Fig.3. Geometric parameters of the three rotary valves (W=blade width; h=blade height; D_r=rotor diameter)*

233
234 Another innovative aspect presented in this paper regards the materials to be used for manufacturing the
235 particle handling systems: in fact, in the new architecture proposed, all the three systems can be made out
236 of stainless steel, even the central one. The latter is the most critical, because it operates at the highest
237 temperatures; however, the external cooling system (achieved by means of the internal channel for the
238 compressed air, see Fig. 1 and 2) can allow steel to withstand such critical conditions without having to make
239 the rotor and its blades out of more expensive ceramic materials. The only precautionary measure to be
240 taken for the central rotary valve can be to coat its steel blades and the steel rotor surface with a layer of
241 ceramic material (e.g. alumina), in order to enhance the thermo-mechanical resistance of the surfaces in
242 contact with the hot particles.

243 Unlike the top and bottom rotary valves, the central one presents a hole in its cover, which is connected with
244 the top column by means of an additional pipe. This solution is needed to facilitate the passage of the
245 particles from the top column into the chamber of the rotor. In fact, after the particles have been discharged
246 from a rotor chamber into the bottom column, the chamber is full of compressed air, which needs to be
247 ejected from the chamber in order to lower the pressure to the atmospheric value and attain the same
248 pressure as that of the top column, thus allowing the particles to enter the rotary valve more effectively. The
249 air ejected from the hole is recovered by means of the above-mentioned pipe and delivered into the top
250 column.

251 The particles must be introduced at the top of each column as uniformly as possible over the entire diametral
252 section of the column, in order to maximize the heat exchange with the counter-flowing gas (which is
253 combustion gas in the top column and compressed air in the bottom one). For this reason, a distribution grid

254 is placed downstream of the rotary valve in both columns in order to distribute the particles over the entire
255 flow area.

256 The volume of each rotary valve can be calculated by using the following equation:

$$G_p = \lambda_v \rho_p V n n_{mod} \quad (1)$$

257 where G_p is the overall particle mass flow rate, λ_v is the filling coefficient (which takes into account the real
258 volume occupied by the particles within the rotor chamber), ρ_p is the particle density, V is the volume of the
259 particles discharged per revolution, n is the rotational speed and n_{mod} is the number of modules the IPHE is
260 split into. Using the symbols shown in Fig. 3, the volume calculated through equation (1) can be related to
261 the width (W) and height (h) of the blades as follows:

$$V = \xi W h (D_r + h) \pi \quad (2)$$

262 where ξ is a coefficient taking into account the blade thickness and D_r is the diameter of the rotor. In order
263 to achieve an optimum filling, the width of the blades (W) should be taken large, whereas their height (h)
264 and the diameter of the rotor (D_r) should both be taken small. As an example, having adopted the geometric
265 relations $h = W/2$ and $D_r = W$, equation 2 becomes equation (3) allowing the width of the blades (W) to be
266 calculated:

$$V = \xi \frac{3W^3}{4} \pi \quad (3)$$

267 The implementation of the three particle handling systems along with the pneumatic conveyor causes a small
268 quantity of compressed air to move from the bottom column into the top one. This compressed air escaping
269 the bottom column does not move to the external environment but enters the top column, thus being useful
270 for the bottoming cycle. However, this must be considered as a loss of compressed air, because such a small
271 quantity of compressed air cannot expand through the gas turbine. The total loss of compressed air $G_{a,lost}$ is
272 the sum of the following contributions:

273 1) Quantity of compressed air ($G_{a,lost,1}$) moving from the bottom column to the top one because of the
274 pressurization system (central rotary valve). This loss is due to the fact that, after the particles have
275 been discharged from a chamber (volume comprised between two blades) of the rotary valve into
276 the bottom column, the chamber is full of compressed air. This air needs to be ejected from the
277 chamber in order to lower the pressure to the atmospheric value; this is achieved by means of a pipe
278 connecting the top column with the rotor. This loss can be calculated as follows:

$$G_{a,lost,1} = \rho_3 V n n_{mod} \quad (4)$$

279 where ρ_3 is the density of the compressed air at the outlet of the bottom column.

280 2) Quantity of compressed air ($G_{a,lost,2}$) moving from the bottom column to the pneumatic conveyor
281 because of the bottom rotary valve. This loss is due to the fact that a small quantity of compressed
282 air occupies the interstices comprised among the particles within the rotary valve during the particle

283 transfer from the bottom column into the pneumatic conveyor; as a result, this compressed is
284 transferred into the pneumatic conveyor together with the particles. This loss can be calculated as
285 follows:

$$G_{a,lost,2}=(1-\lambda_v)\rho_2' Vn n_{mod} \quad (5)$$

286 where ρ_2' is the density of the compressed air at the inlet of the bottom column.

287 3) Quantity of compressed air ($G_{a,lost,3}$) taken from the compressor to lift the particles from the bottom
288 to the top of the plant. In this regard, it must be considered that the power required to lift the
289 particles (equal to $G_p g H$, where g is the gravitational acceleration and H is the total height of the
290 IPHE) multiplied by the efficiency of the pneumatic conveyor η_{conv} must equal the mechanical power
291 taken off the gas turbine. By equating these two quantities, one obtains the air mass flow required
292 by the pneumatic conveyor:

$$G_{a,lost,3} = \frac{G_p g H}{(i_3-i_4)\eta_{conv}} \quad (6)$$

293 This analysis has neglected the loss of compressed air that passes between the blade of the rotor and the
294 cover and that moves from the bottom column to the top column. This further loss can be neglected for two
295 reasons, both due to the use of metallic material (steel). The first reason is that the employment of metallic
296 material allows the clearance between the inner diameter of the case and the rotor blade to be reduced as
297 much as possible. In addition, the use of metallic material allows an easy and effective design of air tight
298 systems (Fig. 3 shows an air tight system achieved with labyrinth seals which prevent air leakage to the
299 external environment).

300 2.3 Architecture and analytical modelling of the top and bottom columns

301 The architecture conceived in this paper for both columns is different from that presented in previous studies
302 [24]; in the new solution presented here, the compressed air coming from the compressor is delivered to the
303 top of the IPHE, from which it flows downwards within an internal channel comprised between the external
304 casing and the walls of the columns. During this path, the compressed air cools the walls of the IPHE until
305 reaching the inlet of the bottom column; at this point, the compressed air inverts its direction and flows
306 upwards and is heated by the particles until it reaches the outlet of the bottom column (which is connected
307 to the gas turbine). Contemporaneously, the hot gases enter the top column and heat the particles up during
308 their upward motion.

309 This new solution has been introduced because it has the potential not only to dramatically reduce the capital
310 costs (by avoiding using ceramic and/or composite materials) but also to minimize the thermal dispersion
311 towards the external environment. The latter feature can further be enhanced by insulating the external
312 casing of the heat exchanger.

313 The diameters and heights of both columns as well as the particle diameter and the particle flow rate must
 314 be chosen properly to achieve the desired heat exchange efficiency of the IPHE, η_{IPHE} , which can be defined
 315 as follows (see Fig. 1 for symbols):

$$\eta_{IPHE} = \frac{i_3 - i_2}{i_5 - i_2} \quad (7)$$

316 In the top column, the thermal power released by the hot gases is acquired mainly by the particles and
 317 partially by the compressed air. This heat transfer in the top column can be expressed as follows (see Fig. 2
 318 for symbols):

$$(G_a + G_b)(i_5 - i_6) = G_p(i_{p,top} - i_{p,press}) + G_a(i_{2'} - i_2) \quad (8)$$

319 where $i_{p,top}$ and $i_{p,press}$ are the enthalpies of the particles at the top and bottom of the top column,
 320 respectively; $i_{2'}$ denotes the enthalpy of the compressed air exiting the external channel of the top column.
 321 In the bottom column, the heat transfer between the particles and the compressed air is given by equation
 322 9:

$$G_a(i_3 - i_{2'}) = G_p(i_{p,press} - i_{p,bottom}) \quad (9)$$

323 where $i_{p,bottom}$ denotes the enthalpy of the particles exiting the bottom column. The latter can be related
 324 to the enthalpy of the particles entering the top column, $i_{p,top}$, as follows:

$$i_{p,top} = i_{p,bottom} - \Delta i_{p,loss} \quad (10)$$

325 where $\Delta i_{p,loss}$ represents the enthalpy that the particles lose during their rise from the bottom to the top of
 326 the plant. It is crucial to design the bottom and top particle handling systems as well as the pneumatic
 327 conveyor so that $\Delta i_{p,loss} \sim 0$. To accomplish this, these systems must be insulated properly; and this is a simple
 328 task because the particles moving from the bottom to the top of the plant have a low temperature, which is
 329 expected to be slightly higher than the temperature of the air exiting the compressor (T_2). In addition, the
 330 heat exchange between the particles and the air can be neglected in the conveyor, because the quantity of
 331 air mass flow rate taken by the pneumatic conveyor is very small and has a temperature level very similar to
 332 that of the particles exiting the bottom column (the air is taken from the compressor outlet at the
 333 temperature T_2).

334 335 2.4 Computational fluid dynamics modelling of the top and bottom columns

336 By virtue of the symmetry of the geometry, and in order to reduce the computational time, only a quarter of
 337 the fluid domain can be meshed for both columns by using the software Ansys Fluent [25].

338 Fig. 4 shows the whole architecture of the top column and the part of the top column that was simulated,
 339 namely only the part needed for the heat exchange between the particles and the counter flowing gas. The
 340 distribution grid at the top of the column must be designed so as to distribute the particles over the entire
 341 flow section; similarly, the inlet ducts for the combustion gases are to be designed so as not to distort the

342 gases ascending the top column, in addition to ensuring negligible pressure drops. The CFD analysis was
343 therefore conducted only on the part of the top column responsible for the heat exchange with the
344 hypothesis that both the particles are injected over the entire flow area and the hot gases enter this part of
345 the column uniformly. In this manner, it was possible to let the optimization procedure effectively find out
346 the values of the diameter and height of the top column (D_{top} and H_{top}) that are necessary to achieve the
347 desired heat exchange. After the diameters and heights have been found by the optimization procedure, it
348 will be possible to correctly design both the particle distribution grid and the inlet ducts in order to achieve
349 the above-discussed features. This will be the objective of forthcoming studies. Fig. 5 shows the structured
350 grid generated for the top column along with the zone types employed, which are also visible in Fig. 4 for
351 ease of comprehension. The two fluids, namely the compressed air and combustion gases, are counter-
352 flowing and are separated by a solid domain, which is meshed with hexahedral elements. The combustion
353 gases enter the internal domain through *Inlet 1* and exit the internal domain through *Outlet 1*;
354 simultaneously, the compressed air enters the external domain through *Inlet 2* and exits the external domain
355 through *Outlet 2*.

356

357

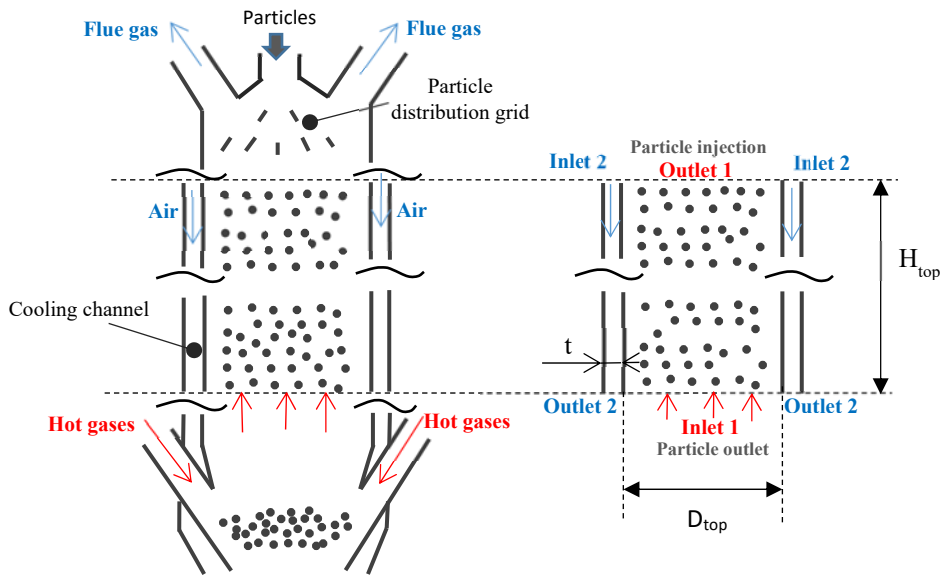

358
 359 Figure 4. Architecture for the top column (left) and simulated part (right)
 360 (design parameters: H_{top} and D_{top} ; fixed parameter: $t=0.06\text{m}$)
 361

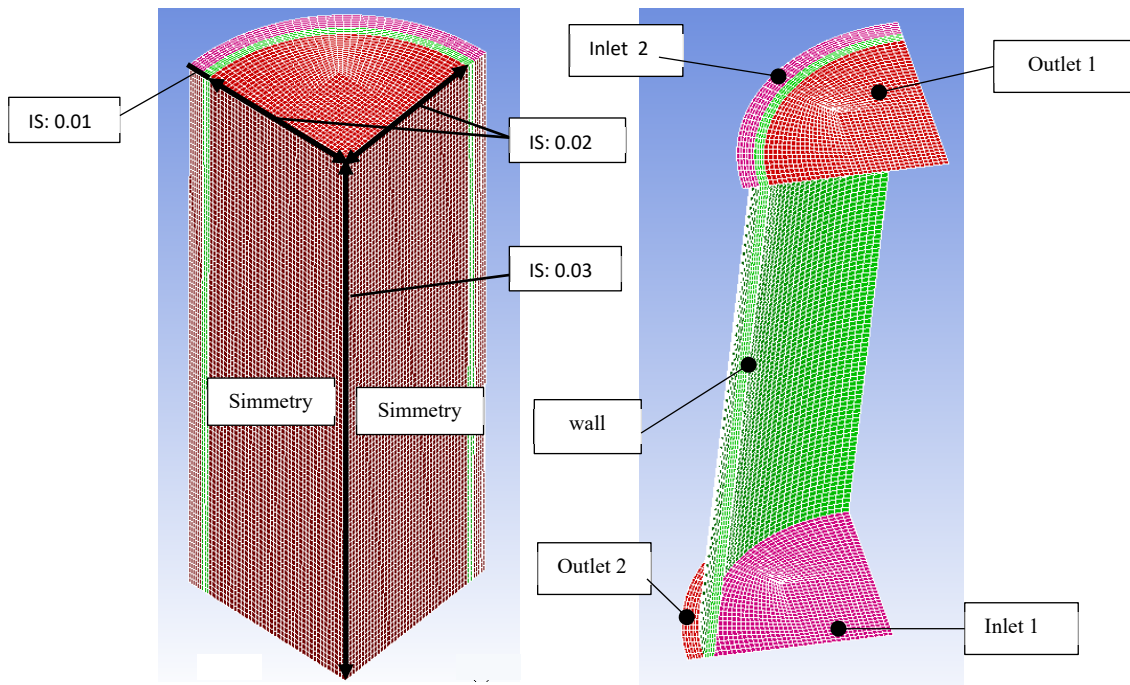

362
 363
 364 Fig. 5. Computational grid employed for the top column, example for $D_{top}=1.5\text{ m}$ and $H_{top}=3\text{m}$.
 365 (IS=interval size expressed in meters)
 366

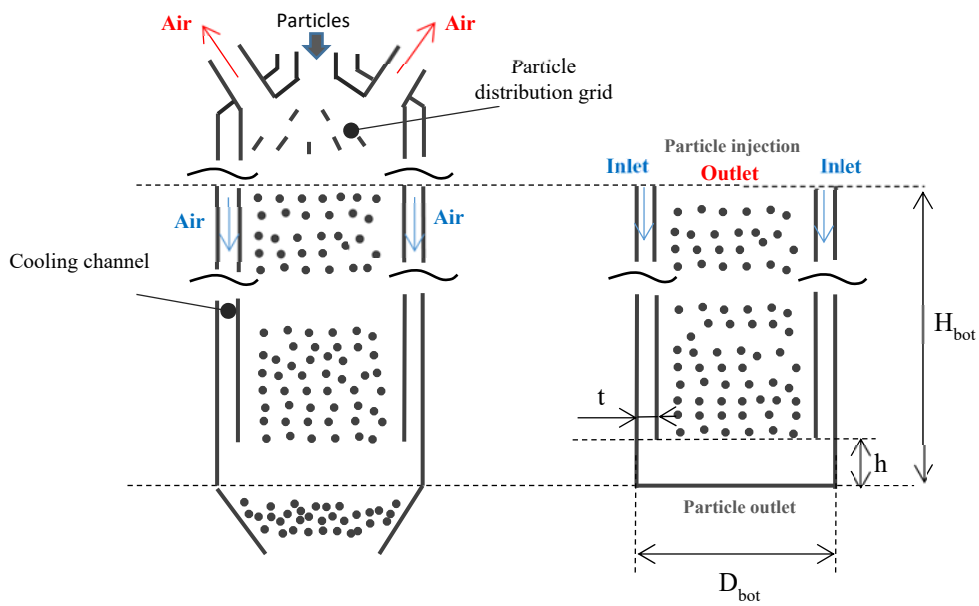

367

368

Fig. 6. Architecture for the bottom column (left) and simulated part (right)

369

(design parameters: H_{bot} and D_{bot} ; fixed parameters: $t=0.06m$ and $h=0.3m$)

370

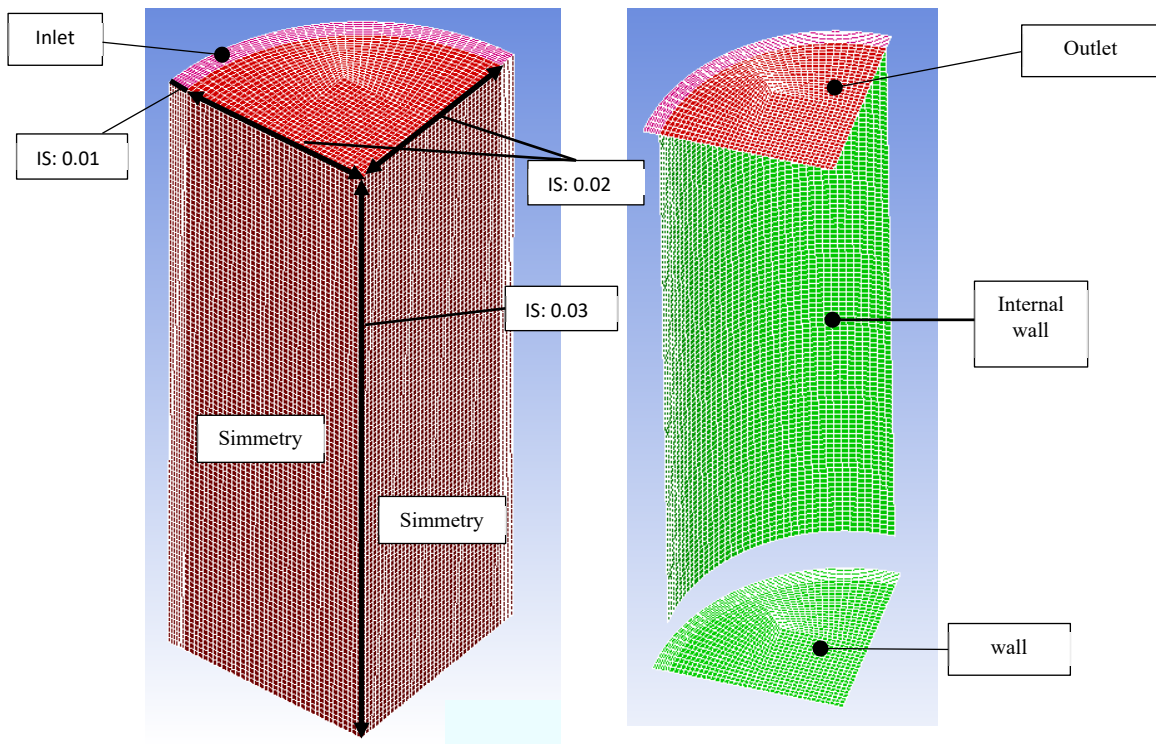

371

372

373

Fig. 7. Computational grid employed for the bottom column; example for $D_{top}=1.5 m$ and $H_{top}=3m$

374

(IS=interval size expressed in meters)

375

376

377 Similarly, Fig. 6 shows the whole architecture of the bottom column and the simulated part. Also in this case,
378 the zone associated with the distribution grid was not simulated, as the aim of this work is to find the
379 dimensions (height and diameter) of the part necessary to achieve the desired heat exchange for both
380 columns. Fig. 7 shows the computational grid generated for the bottom top column along with the zone types
381 employed (which can also be seen in Fig. 6). The compressed air enters the external domain through the *Inlet*
382 and flows through the external channel comprised between the inner and the outer walls. After having
383 entered the bottom column through an internal section, the air flows upwards and exits the domain through
384 the *Outlet*. In this case, the wall separating the external channel from the internal part of the column is not
385 meshed; instead, an internal surface is used and defined as an internal wall with a specified thickness. This
386 strategy is used to avoid meshing a very thin solid domain (in the bottom column, the wall separating the flux
387 of descending air from the flux of ascending air can be designed very thin because the two fluxes have the
388 same pressure).

389 For both mesh typologies, the two surfaces where the physical geometry and the flow pattern have mirror
390 symmetry are defined as symmetry zones.

391 With regard to the mesh setting employed in the optimization process, the strategy was to mesh fixed edges
392 with fixed interval sizes, as shown in Fig. 4 and Fig. 6. The remaining edges were meshed with an interval size
393 necessary to achieve a structured grid in the entire domain. With this setting, the size of the computational
394 grid (number of cells) depends on the values of the dimensions (e.g., the computational grids reported in Fig.
395 5 and Fig. 7 have a size of about 150000 cells), but the simulation of the fluid is very similar for all the
396 geometries explored by the optimizer regardless of their dimensions, because the interval size is the same
397 for the selected edges. The fixed values of the interval sizes results from a grid independence analysis, not
398 reported here for brevity; the maximum skewness factor is less than 0.5 for all meshes.

399 Table 1 reports the boundary conditions associated with the zone types shown in Figures 5 and 6. The
400 particles in the top and bottom columns are injected, with imposed mass flow rate and temperature, from
401 *Outlet 1* (fig. 5) and *Outlet* (fig.7), respectively; the injected particles are allowed to exit through *Inlet 1* (fig.5)
402 and the bottom *Wall* (fig. 7). The main properties of both the continuous phase and the particles are reported
403 in Table 2. The combustion gas properties were assumed equal to the compressed air properties for
404 simplicity; the conduction inside the particles is neglected because of their small size.

405 The discrete phase model is employed: it is able to solve transport equations for the continuous phase
406 (compressed air or combustion gases), and to simulate the discrete second phase (ceramic particles) in a
407 Lagrangian frame of reference. Fluent computes the trajectories of these discrete phase entities, as well as
408 heat and mass transfer to/from them. The coupling between the phases calculates the impact both on the

409 discrete phase trajectories and on the continuous phase flow. The trajectory is based on the force balance
 410 on the particle (gravity and drag in the present case), while heat transfer calculations are based on the
 411 convective and radiative heat to/from the particle, using the local continuous phase conditions as the particle
 412 moves through the flow.

413 The standard k- ω model is employed to predict turbulence. This model was selected as it shows high
 414 performance for wall-bounded flows, providing high accuracy [25]. Furthermore, it is very suitable for
 415 optimization processes (in which the conditions near walls remarkably change from solution to solution)
 416 allowing for a very accurate near wall treatment with an automatic switch from a wall function approach to
 417 a low-Reynolds number formulation according to the values of y^+ [25].

418 All the equations are solved using second order discretization schemes. With regard to the number of
 419 iterations, about 2000 iterations are needed to reach a very good converge level (less than 10^{-4} in all the
 420 scaled residuals, with the energy residual being of the order of 10^{-6}). As no data are available in the scientific
 421 literature (this architecture is new), the confidence in the CFD model was established by analysing the
 422 residual levels for the energy (which is of the same order as the software default convergence criterion) and
 423 by checking the predicted heat transfer between gas and particles. In fact, using larger interval sizes than
 424 those shown in fig. 5 and fig. 7, the simulations provided inaccurate results in terms of heat exchange: in such
 425 a case, the predicted amount of heat flow that was released from the hot particles was different from the
 426 one transferred to the cold air in the bottom column (the same happened for the top column).

427

428

Column	Zone type	Boundary condition	Values
Top column	Inlet 1	Mass flow inlet	Mass flow rate= $\frac{G_a+G_b}{4 n_{mod}}$ Temperature= T_5
	Outlet 1	Pressure outlet	Pressure= p_6
	Outlet 1	Particle Injection	Particle flow rate= $\frac{G_p}{4 n_{mod}}$ Particle temperature= $T_{p,top}$
	Inlet 2	Mass flow inlet	Mass flow rate= $\frac{G_a}{4 n_{mod}}$ Temperature= T_2
	Outlet 2	Pressure outlet	Pressure= p_6
Bottom column	Inlet	Mass flow inlet	Mass flow rate= $\frac{G_a}{4 n_{mod}}$ Temperature= T_2

	Outlet	Outflow	
	Outlet	Particle Injection	Particle flow rate= $\frac{G_p}{4 n_{mod}}$ Particle temperature= $T_{p,press}$

429 *Table 1. Zone types and boundary conditions employed for both columns (see Fig.1 and Fig.2 for symbols;*
430 *n_{mod} denotes the number of modules the IPHE is split into)*

431

Phase	Density (ρ)	c_p [kJ/kgK] (specific heat)	λ [W/mK] (Thermal conductivity)
Fluid	Incompressible ideal gas	$c_p = \frac{1}{M}(a+bT+cT^2+dT^3)$ [26] a=28.11 b=0.1967*10 ⁻² c=0.4802*10 ⁻⁵ d=-1.966*10 ⁻⁹ M=28.97 kg/kmol; T in K	$\lambda = a+bT+cT^2$ [26] a=0.003782 b=7.948*10 ⁻⁵ c=-1.610*10 ⁻⁸ T in K
Particles	3600 kg/m ³	$c_p = a+bT+cT^2+dT^3$ [26] a=175.7 b=2.8085 c=2.5814*10 ⁻³ d=8.268*10 ⁻⁷ T in K	Particle conduction is neglected
Internal walls	Solid (steel)	502.48 J/(kgK)	16.27 W/(mK)

432 *Table 2. Properties set for the fluid, particles and the internal walls*

433

434

435 2.5 Optimization process

436 In order to accomplish the task of designing both columns so as to achieve the desired heat exchange
437 efficiency η_{IPHE} , an optimization process design is proposed that is based on the coupling between a genetic
438 algorithm and a CFD analysis of the heat exchange between the particles and the gas within both columns.
439 The optimization design consists in a sequential and iterative process implemented in the optimization
440 software ModeFRONTIER [27]. With regard to the optimization algorithm, MOGAII was chosen as the
441 optimizer; the efficiency of the employed algorithm is due to the new “directional cross-over” operator,
442 which outperforms the classical “two point cross-over” [28]. The parameters chosen for MOGA II are shown
443 in table 3: the effectiveness of this setting was demonstrated in previous studies [29].

444

Parameter	Value
Probability of directional cross over	0.5

Probability of Selection	0.05
Probability of Mutation	0.1
Elitism	enabled

Table 3 .Parameters of MOGA II

445

446

447 The initial population was generated by the employed DOE algorithm (Constraint Satisfaction, with a number
448 of individuals equal to 100, which corresponds to the number of individuals per generation).

449 The chosen design parameters are: number of heat exchangers (n_{mod}), height (H_{top}) and diameter (D_{top}) of the
450 top column, height (H_{bot}) and diameter (D_{bot}) of the bottom column, particle diameter (D_p). The first design
451 parameter, namely the number of heat exchangers (n_{mod}), is introduced to explore the possibility of splitting
452 the IPHE into more modules, with each module being composed of a top column coupled with a bottom
453 column. In the optimization procedure, this parameter determines how many parts the gas flow rate (G_a+G_b),
454 the air flow rate (G_a) and the particle flow rate (G_p) must be split into. Therefore, according to the value of
455 n_{mod} , the boundary conditions are calculated as shown in Table 1. To avoid the generation of large but short
456 columns, the constraints $H_{top}>D_{top}$ and $H_{bot}>D_{bot}$ were imposed. With regard to the value assumed for the
457 particle flow rate G_p , it was fixed equal to the values of the gas flow rate G_a+G_b , in order to reduce the number
458 of design parameters.

459 The objectives are the minimization of the overall heat exchange surface S_{tot} and the minimization of the
460 difference $|T_{3,sim} - T_3|$, where $T_{3,sim}$ is the predicted temperature of the air exiting the bottom column and
461 T_3 is the desired fixed inlet temperature of the gas turbine. The minimization of the overall heat exchange
462 surface was chosen as objective because it is important to design the heat exchanger as compact as possible:
463 the bulkier the heat exchanger, the more expensive the overall cost. Furthermore, the implementation of a
464 very large heat exchanger would be unfeasible for such a small scale power plant. The large surfaces needed
465 for the heat exchange is a common problem of typical gas to gas heat exchangers, therefore this objective
466 allows understanding whether the novel architecture of the IPHE can effectively overcome this issue. The
467 second objective was chosen because the IPHE must provide a desired heat exchange efficiency and hence a
468 desired inlet temperature of the gas turbine.

469 The design parameters, objectives and constraints are summarized in Table 4 for completeness.

470 The evaluation of the individuals is automatically performed through the following procedures:

- 471 (a) CFD simulation of the top column, which leads to the calculation of the predicted temperature of
472 the particles exiting the top column, $T_{p,press, sim}$.
- 473 (b) CFD simulation of the bottom column, aimed at the calculation of the air temperature at the outlet
474 of the bottom column, $T_{3,sim}$.

475 (c) Evaluation of the objectives, selection, crossover and mutation .

Design parameters	$n_{mod}, H_{top}, D_{top}, H_{bot}, D_{bot}, D_p$
Objectives	Minimization of both S_{tot} and $ T_{3,sim} - T_3 $
Constraints	$H_{top} > D_{top}, H_{bot} > D_{bot}$ $ T_{p,press,sim} - T_{p,press} < \epsilon_{tol}$.
Fixed parameters	$G_p = G_a + G_b$ $T_2, T_3, T_5, G_a, G_b, T_{p,press}, T_{p,top}, \eta_{IPHE}$

476 *Table 4. Design parameters, objectives, constraints and fixed parameters (see fig.1 for symbols)*

477 In order to speed up the entire optimization procedure, the passage from step a (CFD simulation of the top
478 column) to step b (CFD simulation of the bottom) column is allowed only if all the particles can fall down and
479 if the predicted particle temperature at the exit of the top column ($T_{p,press,sim}$) reaches the desired value at the
480 exit of the top column, namely $T_{p,press}$ (a tolerance coefficient ϵ_{tol} can be introduced, as shown in Table 4). The
481 latter value ($T_{p,press}$) is a fixed parameter and can be determined, for a given heat exchange efficiency of the
482 IPHE (η_{IPHE}), by using equations 7-10, which can allow fixing the particle temperatures both at the outlet of
483 the top column ($T_{p,press}$) and at the inlet of the top column ($T_{p,top}$). Summarizing, the value of $T_{p,top}$ must be
484 used, in the CFD simulation of the top column, as the injection temperature of the particles into the top
485 column. In contrast, the value of $T_{p,press}$ must be used as the temperature to reach through step a (CFD
486 simulation of the top column), which enables the activation of step b (CFD simulation of the bottom column).
487 A flow chart of the optimization process is reported in Fig. 8.
488 The CFD simulations of the columns represent a great part of the computational cost of the entire procedure,
489 while the optimization process presented here needs to be compatible with typical industrial design time. To
490 address this issue, the computational grid partition together with the parallel processing was employed to
491 reduce the overall processing time. The grid partitioning, or domain decomposition, consists in splitting the
492 computational grid of a single individual into smaller sized grids that allow the contemporary use of more
493 than one processor of the same machine. Such a decomposition speeds up the computation since it fits within
494 the memory limits of the employed machine. In addition, the parallel processing allows the concurrent
495 evaluation of more individuals, and this tool is not available for gradient based algorithms or similar ones,
496 e.g. the Simplex algorithm, which cannot afford multiple evaluations to make decisions. In contrast, a genetic
497 algorithm makes decisions and generates a new population of individuals only after the entire current
498 population has been explored, thus fitting the parallel processing very well.

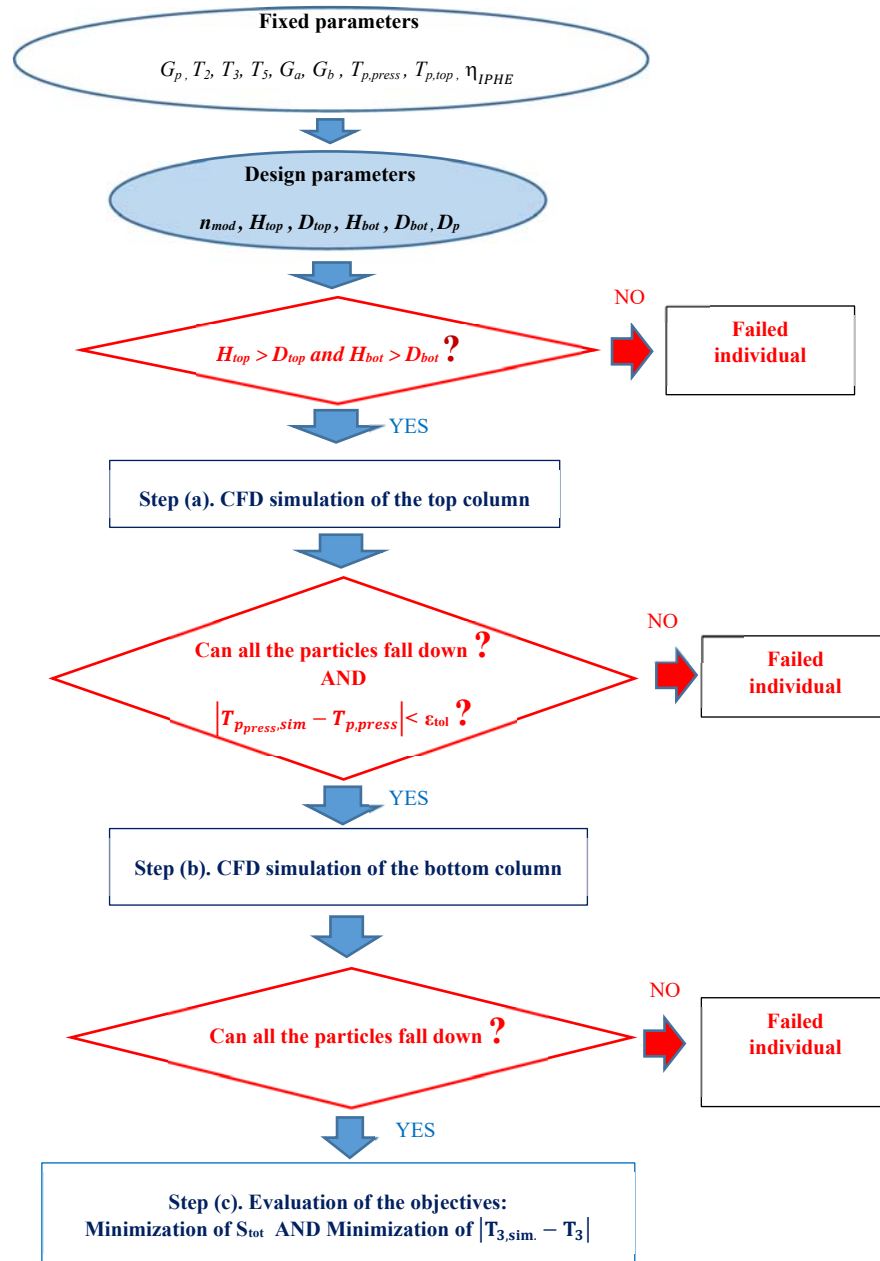

499

500

501

502

3. Results

503

504

505

506

507

508

Fig.8- Flow chart of the optimization process (see Fig.1 for symbols)

The geometric optimization procedure was applied to the small scale combined cycle (see Fig.1) characterized by the thermodynamic values reported in [11] and obtained through the thermodynamic optimization procedure presented in [11]. The study performed in [11] was instrumental in determining the values of the cycle parameters (temperatures and flow rates) that allowed the plant performances to be optimized. Different objective functions were considered, namely the optimization of the electrical efficiency of the combined cycle, the optimization of the thermal efficiency of the combined cycle and the optimization

509 of the overall efficiency of the combined cycle. In this work, the methodology presented in Section 2 is applied
510 to the latter case (optimization of the overall efficiency of the combined cycle). Fig. 9 reports the
511 corresponding values of the thermal parameters and flow rates, namely those parameters that allow the
512 overall efficiency of the combined cycle (electrical efficiency plus thermal efficiency) to be optimized. In these
513 conditions the heat exchange efficiency required to the IPHE, η_{IPHE} (expressed through equation 7), is equal
514 to 0.75. As discussed in [11], the heat exchange efficiency was set to this value so as to increase the
515 temperature of the flue gases entering the HRSG (T_6) and hence to maximize the thermal power transferred
516 in the HRSG, allowing a great quantity of thermal and electrical energy to be generated in the bottoming
517 cycle.

518 The electrical efficiency of the power plan is 0.2212 according to the calculation performed in [11]. This value
519 was determined assuming that the pressure drops in the part of the circuit from the gas turbine exit to the
520 HRSG exit are negligible. This assumption was thoroughly discussed and justified in [11], where each
521 component was analysed in detail. The pressure drops in the HRSG and cyclone separators [29] are usually
522 so low that they can be neglected for the calculation of thermodynamic properties. The IPHE, serving as the
523 HTHE, produces negligible pressure drops either, and this assumption will be verified in the following. The
524 most critical component in terms of pressure drops is usually the combustor; however, it should be noted
525 that, in the present configuration, it operates at ambient pressure and therefore can be designed more
526 effectively than typical pressurized fluidized bed combustor. In addition, the design of the components in the
527 present plant can take advantages of the very low air flow rate of the circuit in order to minimize the pressure
528 losses.

529 In case of non-negligible pressure drops in line 4-7 (see fig.1 and fig.9), a fan would be needed at the exit of
530 the HRSG in order to compensate for these losses. The absorbed power would penalize the net electrical
531 power and hence the efficiency of the plant. Figure 10 shows a graph reporting how the performance of the
532 plant would be penalized by the increasing pressure drop in line 4-7, which evidences the importance of
533 minimizing the pressure drops. According to this calculation, if the pressure drops are maintained within the
534 order of 0.05 Pa, then the electrical efficiency will be reduced by 1% only.

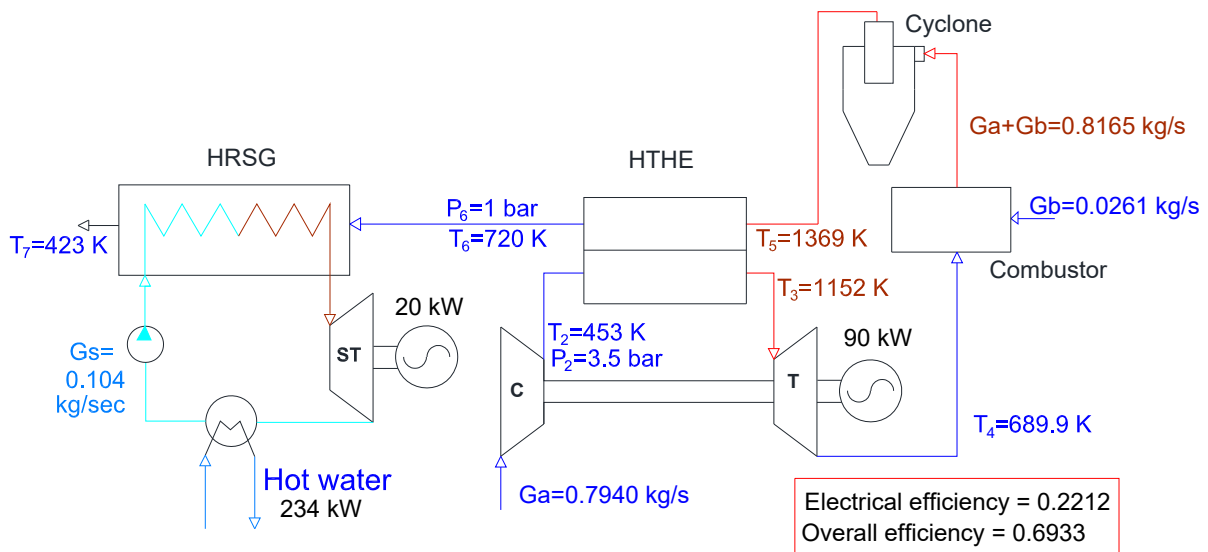

Fig. 9. Case of study for the application of the IPHE

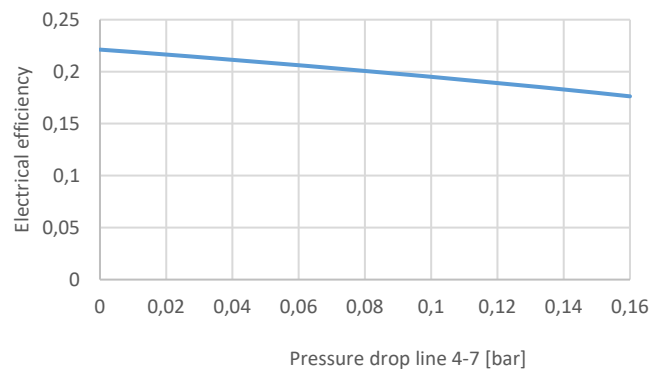

Fig. 10. Electrical efficiency (net electrical power over input thermal power) as a function of the pressure drop in line 4-7

The chosen design space is reported in Table 5; Table 6 reports the values of some thermal parameters fixed in the optimization procedure. As mentioned earlier, the values of both $T_{p,top}$ and $T_{p,press}$ were determined by using equations 7-10. The explanation for these fixed values was exposed in Section 2 thoroughly. Table 6 reports some geometrical parameters fixed for both columns.

Design parameter	Unit	Range	Step	Number of points
number of heat exchangers (n_{mod})	/	1-6	1	6
height of the top column (H_{top})	[m]	0.4-3	0.1	27
diameter of the top column (D_{top})	[m]	0.3-2	0.1	18
height of the bottom column (H_{bot})	[m]	0.4-3	0.1	27

diameter of the bottom column (D_{bot})	[m]	0.3-2	0.1	18
particle diameter (D_p)	[mm]	0.1-1	0.01	91

Table 5. Design space employed in the optimization procedure

Parameter	value
G_p (kg/sec)	0.8165
$T_{p,top}$ (K)	620
$T_{p,press}$ (K)	1220 (tolerance $\epsilon_{tol}= 10$ K)

Table 6. Values assumed in the optimization procedure

Fixed geometrical parameters	value
Width of the external channel [m]	0.06
Width of the internal walls [m]	0.04
Roughness of the walls [m]	$5e^{-05}$
Reflection coefficient (interaction particle-wall)	0.5

Table 7. Geometrical parameters fixed for both columns

The process was stopped after 3000 individuals had been explored (termination criterion). The optimization process was managed by a personal computer equipped with an Intel core i7 processor at 3.3 GHz and 64 GByte of ram. Four configurations were computed in parallel and each configuration was partitioned into two sub-domains. With this hardware resource, and thanks to the strategy described in Section 2.4, two weeks were needed to conclude the optimization.

Fig. 11 reports two geometries explored for the top column by the optimization process. The first geometry (Fig. 11a) is characterized by an internal diameter very small ($D_{top}=0.8m$) but a considerable height ($H_{top}=2.3$ m), with the particle diameter being equal to $D_p=0.26mm$. In contrast, the second geometry (Fig.11b) is larger ($D_{top}=1.2m$) but shorter ($H_{top}=1.8$ m), with a particle diameter of $D_p =0.6$ mm. Both the particle contours and the gas velocity contours reveal that, in the first case, the particles are pushed against the walls and a part of them cannot fall down. This is due to the fact that the particle diameter is too small in comparison with the air velocity, with the latter being very high because of the small column diameter. As a result, the gas and the particles are confined in two different regions of the pipe, flowing separately. This behaviour must be avoided; in contrast, to achieve a correct operation of the IPHE and thus a high heat transfer efficiency, the particles must be distributed as uniformly as possible in all transversal sections; namely, the particle trajectories must be straight too. In the second case, the ratio of the particular diameter to the column diameter is more convenient and both the particles and the gas can flow more uniformly within the column.

569 However, in the latter case the final temperature of the particles is not high as expected, which means that
 570 the combination of design parameters is not optimal.

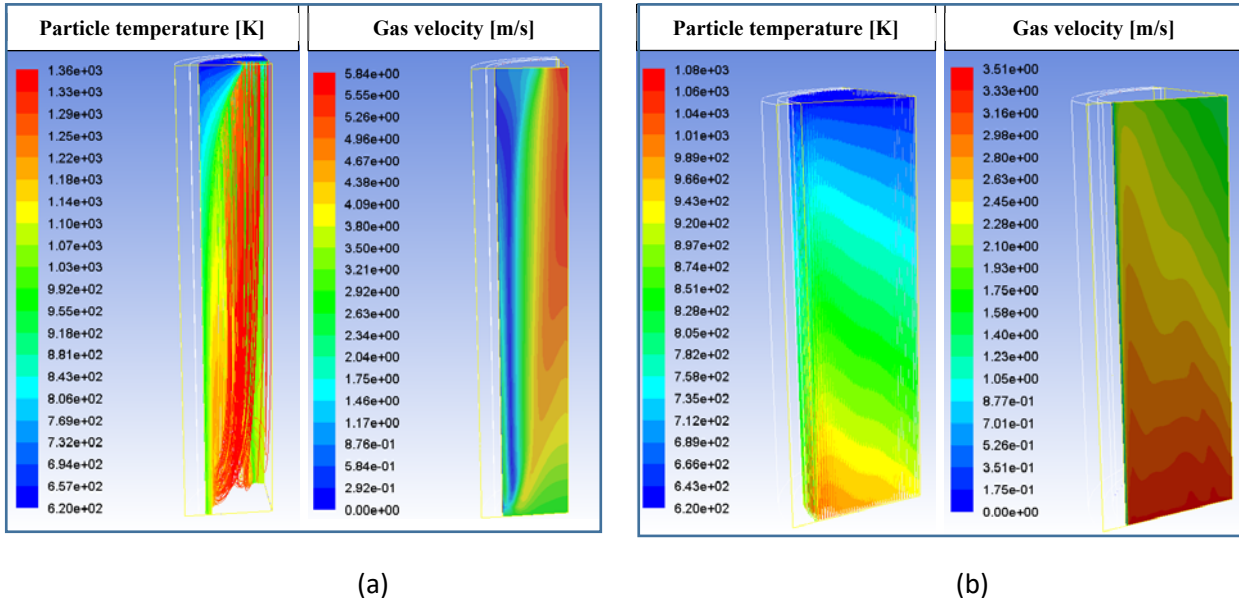

571

572

573 *Fig. 11. Non-optimal geometries for the top column. $D_{top}=0.8m$, $H_{top}=2.3m$ and $D_p=0.26mm$ (a); $D_{top}=1.2m$,*
 574 *$H_{top}=1.8m$ and $D_p=0.6mm$ (b)*

575 This comparison serves as an example to evidence that the particle diameter along with all the other
 576 geometric parameters must be properly selected in order to avoid that the gas flow distort the particle fall,
 577 pushing the particles away from a straight path (or vice-versa). The optimization procedure allows
 578 discovering and discarding the ineffective geometries, thus moving towards optimal solutions.

579 The optimization process allowed the determination of the Pareto Front, which represents the set of those
 580 individuals that are not dominated by any others; in other words, the Pareto Front represents the limit
 581 beyond which the design cannot further be improved. Figure 12 shows each feasible individual (combination
 582 of the design parameters that respect the prescribed constraints) plotted as a point at the location specified
 583 by its values of the objectives, namely S_{tot} and $|T_{3,sim} - T_3|$. Because of the imposed constraints, the number
 584 of feasible individuals results very small. It is possible to observe the Pareto Front located at the frontier of
 585 the feasible individuals; as expected, it is not possible to choose an individual belonging to the front that is
 586 capable of minimizing S_{tot} and minimizing $|T_{3,sim} - T_3|$ at the same time, because these objectives are
 587 conflicting; as a result, the optimum must be chosen according to which of the two performance parameters
 588 must be favoured and to what extent.

589

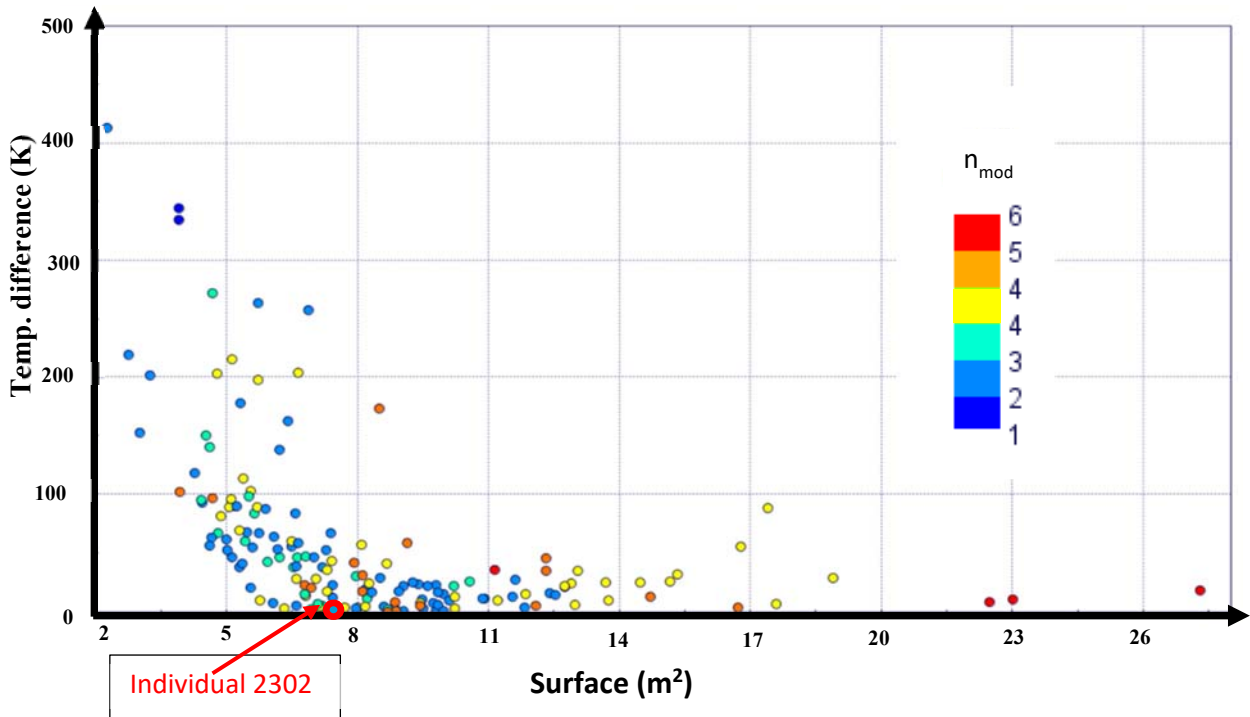

590
591
592
593

Fig. 12. Feasible individuals plotted in the objective space, with indication of the individual selected (individual 2302)

594 In this analysis, the minimization of $|T_{3,sim} - T_3|$ was preferred over the minimization of S_{tot} , because a
595 reduction in T_3 would cause a consequential reduction in the efficiency of the cycle (see fig.9). According to
596 this strategy, the optimum was selected among the non-dominated solutions of the Pareto front
597 characterized by $|T_{3,sim} - T_3|$ being less than 0.5%. Among these, individual 2302 was selected because it
598 has the lowest surface S_{tot} ; its values of the design parameters are reported in Table 8 along with the values
599 of the objectives and constraints.

Individual 2302	
Optimal design parameters	value
number of heat exchangers (n_{mod})	2
height of the top column (H_{top})	2.1 m
diameter of the top column (D_{top})	1.2 m
height of the bottom column (H_{bot})	1.7 m
diameter of the bottom column (D_{bot})	1 m
particle diameter (D_p)	0.26 mm
Objectives and constraints	value

S_{tot} (overall surface)	7.42 m ²
Temperature difference ($ T_{3,sim} - T_3 $)	2.5 K
Predicted particle temperature at the outlet of the top column, $T_{p_press, sim}$	1221 K

Table 8. Individual selected: geometric and thermal parameters

600

601 Fig. 12 refers to the top column of individual 2302; Fig. 12a shows the particles traces coloured by the particle
602 temperature; Fig.12b shows the particles traces coloured by the particle velocity, whereas Fig. 12c shows the
603 contours of gas temperature plotted along the symmetry planes.

604

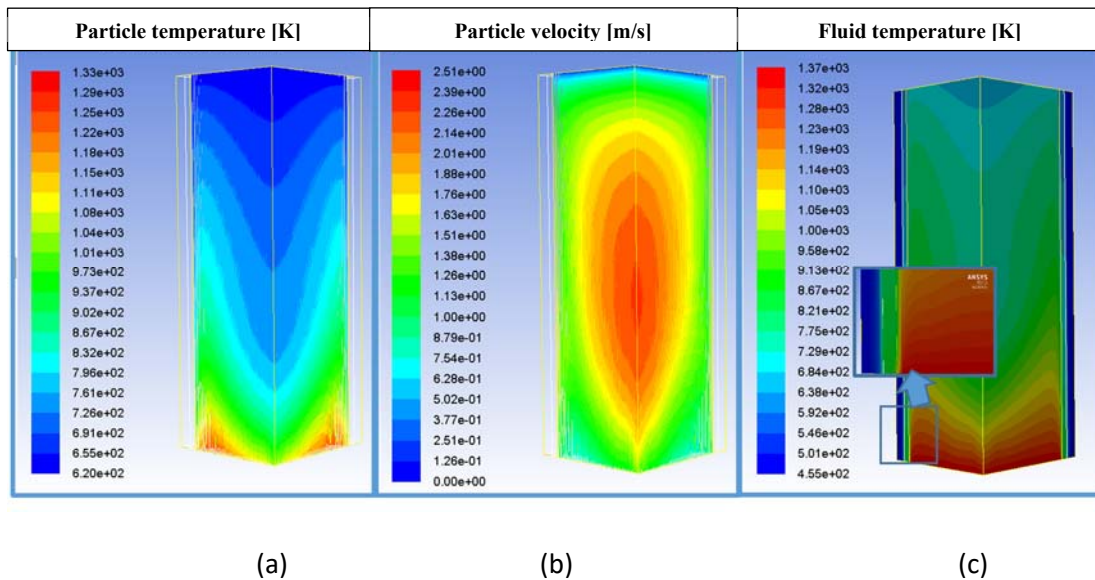

605

606

607 Fig. 12. Particle temperature (a), particle velocity (b) and gas temperature (c) of individual 2302 (top
608 column)

609 Fig. 12a shows that the particles gradually increase their temperatures while descending to the bottom. The
610 final average temperature of the particles is 1221 K (this temperature respects the prescribed constraint, see
611 table 6). As shown in Fig 12b, the velocity of the particles increases while the particles are falling down
612 because of gravity, with the maximum velocity being registered approximately at the centre of the column.
613 After this, the particles slow down because the gas velocity increases from the bottom to the top of the
614 column (because of the gas temperature profiles shown in Fig. 12c) until approaching the bottom of the
615 column with an average velocity of about 0.5 m/s.

616 Similarly, Fig. 13 refers to the bottom column of individual 2302; Fig. 13a, 13b and 13c report, respectively,
617 the particles traces coloured by the particle temperature, the particles traces coloured by the particle velocity
618 and the contours of gas temperatures plotted along the symmetry planes. As shown in Fig. 13c, the
619 compressed air enters the external channel surrounding the bottom column at the temperature of 502 K
620 (which corresponds to the temperature at which it left the top column), flows through the internal channel

621 and finally enters the bottom column through the internal channel. After having exchanged heat throughout
 622 its ascent, the compressed air reaches the average temperature of 1154.5 K at the exit of the top column.
 623 It is possible to observe both in Fig. 12c and in Fig. 13c that the internal wall temperature is maintained at
 624 low values, with the maximum temperature being predicted in the top column (as expected) with a value of
 625 about 870 K. This temperature is tolerable by most steels, also considering that the internal wall of the top
 626 column is subjected to a very low pressure gradient (3.5 bar). With regard to the pressure losses in both
 627 columns, they were predicted to be negligible, with the overall pressure drop suffered by the air from the
 628 inlet to the outlet of the IPHE being 49 Pascal only.

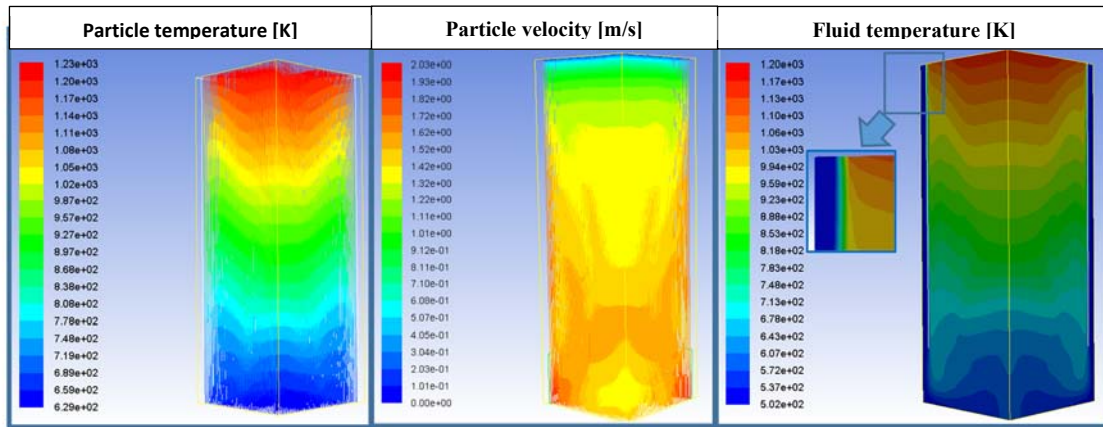

(a)

(b)

(c)

629
 630 *Fig. 12. Particle temperature (a), particle velocity (b) and air temperature (c) of individual 2302 (bottom*
 631 *column)*

632
 633
 634 After having selected the number of heat exchangers, the geometrical values for both columns as well as the
 635 particle diameter, equations 1-3 can be used to design the three particle handling systems. The calculation
 636 of the volume of each rotor (V) can be achieved by using equation (1); however, the following parameters
 637 need to be fixed and/or determined before, specifically: rotational speed of the rotor (n) and filling coefficient
 638 (λ_v). With regard to the rotor speed (n), it must be kept quite slow, in order to ensure a good filling of the
 639 chambers; a value of 0.1 revolution/s was chosen for this calculation. With regard to filling coefficient (λ_v), it
 640 can be assumed equal to 0.5, as the particles are expected to occupy a half of each chamber in the case of a
 641 good filling. With these assumptions, the volume of each rotor results to be equal to $V=0.002268 \text{ m}^3$. In
 642 addition, using a geometry having $h=W/2$, $D_r=W$ and $\xi=0.8$ (see equation 3), it results that the width of the
 643 blades (W) is equal to 10.63 cm, the height (h) of the blades is 5.32 cm and the diameter of the rotor (D_r) is
 644 10.63 cm. The main assumptions and geometric parameters are also reported in Table 9.

645

Rotary valve	value
n [rpm]	6
λ_v	0.5
ξ	0.9
Volume per revolution (V) [m ³]	0.002268
Blade width (W) [cm]	10.63
Blade height (H) [cm]	5.315
Rotor diameter (D _r) [cm]	10.63

Table 9. Rotary valve dimensions and parameters

646

647

648 With regard to the loss of compressed air, it can be calculated by using equations 4-6. Assuming that the
649 pneumatic conveyor has an efficiency equal to $\eta_{\text{conv}}=0.2$ one obtains:

$$\begin{aligned}
 G_{a,\text{lost},1} &= 0.000481 \text{ kg/s} \rightarrow \frac{G_{a,\text{lost},1}}{G_a} = 0.0606\% \\
 G_{a,\text{lost},2} &= 0.000614 \text{ kg/s} \rightarrow \frac{G_{a,\text{lost},2}}{G_a} = 0.0774\% \\
 G_{a,\text{lost},3} &= 0.000614 \text{ kg/s} \rightarrow \frac{G_{a,\text{lost},3}}{G_a} = 0.0757\% \\
 G_{a,\text{lost}} &= 0.794 \text{ kg/s} \rightarrow \frac{G_{a,\text{lost}}}{G_a} = 0.214\%
 \end{aligned}
 \tag{11}$$

650 Table 10 reports the losses of compressed air for completeness. The sum of the three contributions shows
651 that the overall loss of compressed air is absolutely negligible, being of the order of 0.2% of the overall
652 compressed air delivered by the compressor.

Loss of compressed air	Value (%)
First contribution of loss of compressed air $\left(\frac{G_{a,\text{lost},1}}{G_a}\right)$ [%]	0.0606
Second contribution of loss of compressed air $\left(\frac{G_{a,\text{lost},2}}{G_a}\right)$ [%]	0.0774
Third contribution of loss of compressed air $\left(\frac{G_{a,\text{lost},3}}{G_a}\right)$ [%]	0.0757
Overall loss of compressed air $\left(\frac{G_{a,\text{lost}}}{G_a}\right)$ [%]	0.214

Table 10. Losses of compressed air

653

654 Summarizing, the application of the approach described in section 2 has led to the conclusion that the IPHE
655 should be split into two modules, with both being characterized by an overall height necessary for the heat
656 exchange of 3.8 m (height of the top column plus height of the bottom column), with a maximum diameter
657 of 1.2 m (representing the diameter of the bottom column). The particles should be manufactured with a
658 diameter of 0.26 mm to make the above dimensions of the columns effective, thus achieving the desired

659 heat exchange efficiency. As expected, because of the large difference in density between gas and ceramic
660 particles, the three rotary valves result to be very small, with a volume per revolution of 0.002268 m³. These
661 data regard a specific case of application, namely a small scale combined cycle capable of generating an
662 electrical power of 110 kWe and a thermal power of 234 kW, with an air mass flow rate of about 0.8 kg/s and
663 a HTHE efficiency of 0.75. In these conditions, the size of the IPHE results to be quite compact, evidencing
664 that its implementation into a real plant would not present particular issues in terms of dimensions. The low
665 size is due to the high overall heat exchange coefficient that in turn results from the uniform dispersion of
666 the thermal vector (the ceramic particles) within the gas stream. It should be noted that the increase in the
667 heat exchange efficiency, η_{IPHE} , would require higher heights for the columns; however, the analysis
668 reported in [11] demonstrated that the achievement of very high values for η_{IPHE} is not necessary, as the
669 increase in η_{IPHE} causes a reduction in the gas temperature entering the HRSG. Furthermore, the CFD
670 analysis of both columns has shown that the architecture proposed for both columns allows the temperature
671 of the walls to remain within low values which are tolerable by most steels results. This feature is particularly
672 important, because the use of steel for both columns (instead of ceramic material) can allow constructing
673 the columns easily and with low costs. As a result, the manufacturing and assembly of the IPHE does not
674 represent an issue, also considering that even the particle handling systems can be manufactured out of steel
675 thanks to the architectures proposed. With regard to the loss of compressed air, it was demonstrated that
676 only a negligible part (0.2% of the flow rate suctioned by the compressor) is lost because of the particle
677 handling systems. In addition, the pressure drops caused by both columns is absolutely negligible. These
678 results have shown that the project is highly viable, thus encouraging further studies and the forthcoming
679 experimental validation of the project.

680

681 **4. Conclusions**

682 The aim of this paper was to propose a general approach for the design of the immersed particle heat
683 exchanger (IPHE), suitable to external combustion plants using alternative or dirty fuels, such as carbon-
684 neutral biomass. In particular, the focus was the application of the IPHE to a novel typology of small scale
685 combined cycles proposed in previous studies. Taking advantages of the preliminary results achieved in
686 previous studies, new technical solutions having general validity were studied, proposed and modelled in this
687 paper. The immersed particle heat exchanger employs solid particles as an intermediate solid medium to
688 transfer heat from the hot gases (exiting the external combustor at low pressure) to the compressed air
689 (exiting the compressor at high pressure); because of this architecture, three particle handling systems plus
690 a pneumatic conveyor are needed to move the solid medium between the two columns. The solution
691 proposed for each particle handling system is mainly composed of a convergent reservoir, a guillotine valve

692 and a rotary valve. With regard to the latter, it can be easily implemented into the IPHE because it is a
693 component widely used in several industrial fields, allowing particles and loose material to be moved from
694 two environments at different pressures, being mainly composed of a gear rotor spinning within a cover
695 interposed between two environments at different pressure. Analytical models were developed that are
696 based on simple equations allowing both the main dimensions of the particle handling systems to be
697 determined and the loss of compressed air (due to the presence of these systems) to be estimated. Besides,
698 a new architecture for both columns was conceived in this paper taking advantage of previous architectures
699 presented in previous studies; the main difference is that the compressed air coming from the compressor,
700 before entering the bottom column, is forced to flow through an internal channel comprised between the
701 external casing and the walls of the columns. During this path, the compressed air cools the walls of the IPHE
702 until reaching the inlet of the bottom column; this new solution has the potential not only to dramatically
703 reduce the capital costs (by avoiding using ceramic and/or composite materials) but also to minimize the
704 thermal dispersion towards the external environment. In respect of this new architecture, a thorough
705 optimization design procedure was developed in this paper in order to select the optimum values of the IPHE
706 modules, diameters and heights of both columns as well as the particle diameter that allow achieving the
707 desired heat exchange efficiency. The optimization design is based on the interaction among simple analytical
708 equations (allowing fixing some necessary thermal parameters), a genetic algorithm (MOGA II) and a
709 thorough CFD analysis of the heat exchange between the particles and the gas within both columns. As far
710 as the CFD modelling phase is concerned, only a quarter of the fluid domain was be meshed for both columns,
711 taking advantage of the symmetry of the geometry. The main features of this CFD analysis (including
712 geometry, zone types, boundary conditions, model and material properties) as well as the optimization
713 strategy (including the characteristics of the optimization algorithm, constraints and objectives) were
714 reported thoroughly.

715 The optimization procedure, which has general validity (in that it can be applied to different values of the
716 parameters characterizing the combined cycle) was tested with application to specific values of thermal
717 parameters and flow rates of a combined cycle capable of producing about 110 kW_e; in these conditions, the
718 thermal efficiency of the IPHE is equal to 0.75. With regard to the result of the optimization procedure, it was
719 found that the IPHE must be split into two modules having small size, showing the feasibility of the project
720 in terms of dimensions. In addition, it was shown that the internal wall temperature is maintained within low
721 values by virtue of the new architecture proposed, with the maximum temperature being predicted in the
722 top column (as expected) with a value of about 870 K, allowing for the use of stainless steels instead of more
723 expensive ceramic and/or composite materials. With regard to the loss of compressed air due to the
724 employment of the particle handling systems, it was demonstrated, by using the proposed analytic equations,
725 that overall loss of compressed air is absolutely negligible.

726 The application of the whole design procedure to a specific case has shown that project is highly viable; the
727 next step will be the experimental validation of the entire project idea, with the construction of a pilot plant
728 composed of an externally fired combined cycle coupled with the high temperature gas to gas heat exchanger
729 (by means of a project funded by Apulia Region, at the LabZero Research Centre of Polytechnic University of
730 Bari in the south of Italy).

731 In addition to demonstrating the viability of the project, this paper was aimed at providing the necessary
732 tools and a general validity design procedure which can help other researchers and/or industrial
733 manufacturers to design and construct prototypes of high temperature gas to gas heat exchangers to be
734 applied to small scale externally fired gas turbines or combined cycles for the distributed energy generation
735 from carbon-neutral biomass.

736
737
738
739

740 5. References

- 741 1. Vandyck, T., Keramidis, K., Saveyn, B., Kitous, A., & Vrontisi, Z. (2016). A global stocktake of the Paris
742 pledges: Implications for energy systems and economy. *Global Environmental Change*, 41, 46-63.
- 743 2. Amelio, M., Ferraro, V., Marinelli, V., & Summaria, A. (2014). An evaluation of the performance of an
744 integrated solar combined cycle plant provided with air-linear parabolic collectors. *Energy*, 69, 742-
745 748.
- 746 3. Amirante, R., Cassone, E., Distaso, E., & Tamburrano, P. (2017). Overview on recent developments in
747 energy storage: Mechanical, electrochemical and hydrogen technologies. *Energy Conversion and*
748 *Management*, 132, 372-387.
- 749 4. Loha C., Chatterjee P.K., Chattopadhyay, H. (2011). Performance of fluidized bed steam gasification
750 of biomass—modeling and experiment. *Energy Convers Manage*, 52(3):1583–8.
- 751 5. Loha, C., Chattopadhyay, H., & Chatterjee, P. K. (2014). Three dimensional kinetic modeling of
752 fluidized bed biomass gasification. *Chemical Engineering Science*, 109, 53-64
- 753 6. Borsukiewicz-Gozdur A, Wis´niewski S, Mocarski S, Ban´kowski M. ORC power plant for electricity
754 production from forest and agriculture biomass. *Energy Convers Manage* 2014;87:1180–5.
- 755 7. Zhang C, Shu G, Tian H, Wei H, Liang X. Comparative study of alternative ORC based combined power
756 systems to exploit high temperature waste heat. *Energy Convers Manage* 2015;89:541–54.
- 757 8. Dai Y, Wang J, Gao L. Parametric optimization and comparative study of organic Rankine cycle (ORC)
758 for low grade waste heat recovery. *Energy Convers Manage* 2009;50(3):576–82.
- 759 9. Wei D, Lu X, Lu Z, Gu J. Performance analysis and optimization of organic Rankine cycle (ORC) for
760 waste heat recovery. *Energy Convers Manage* 2007;48(4):1113–9.
- 761 10. Capata R, Toro C. Feasibility analysis of a small-scale ORC energy recovery system for vehicular
762 application. *Energy Convers Manage* 2014;86:1078–90
- 763 11. Amirante, R., & Tamburrano, P. (2015). Novel, cost-effective configurations of combined power plants
764 for small-scale cogeneration from biomass: Feasibility study and performance optimization. *Energy*
765 *Conversion and Management*, 97, 111-120.
- 766 12. Amirante, R., Clodoveo, M. L., Distaso, E., Ruggiero, F., & Tamburrano, P. (2016). A tri-generation plant
767 fuelled with olive tree pruning residues in Apulia: An energetic and economic analysis. *Renewable*
768 *Energy*, 89, 411-421.

- 769 13. Rovense, F., Amelio, M., Ferraro, V., & Scornaienchi, N. M. (2016). Analysis of a Concentrating Solar
770 Power Tower Operating with a Closed Joule Brayton Cycle and Thermal Storage. *International Journal*
771 *of Heat and Technology*, 34(3), 485-490.
- 772 14. Soltani, S., Mahmoudi, S. M. S., Yari, M., & Rosen, M. A. (2013). Thermodynamic analyses of an
773 externally fired gas turbine combined cycle integrated with a biomass gasification plant. *Energy*
774 *Conversion and Management*, 70, 107-115.
- 775 15. Santos, M. J., Merchán, R. P., Medina, A., & Hernández, A. C. (2016). Seasonal thermodynamic
776 prediction of the performance of a hybrid solar gas-turbine power plant. *Energy Conversion and*
777 *Management*, 115, 89-102.
- 778 16. Jeong JH, Kim LS, Lee JK, Ha MY, Kim KS, Ahn YC. Review of heat exchanger studies for high-efficiency
779 gas turbines. In *ASME Turbo Expo 2007: Power for Land, Sea, and Air*. American Society of Mechanical
780 Engineers; January 2007. p.833–40
- 781 17. C. F. McDonald, Recuperator considerations for future higher efficiency microturbines, *Applied*
782 *Thermal Engineering*, vol. 23, no. 12, pp. 1467–1487, 2003.
- 783 18. D. G. Wilson and J. M. Ballou, Design and performance of a high-temperature regenerator having very
784 high effectiveness, lowleakage and negligible sealwear, in *Proceedings of theASME Turbo Expo*, pp.
785 183–197, Barcelona, Spain, May 2006.
- 786 19. B. J. Tsai and Y. L.Wang, “A novel Swiss-Roll recuperator for the microturbine engine,” *Applied*
787 *Thermal Engineering*, vol. 29, no. 2-3, pp. 216–223, 2009.
- 788 20. P. Zimmermann, A. Cardenas, C. Hirsch, and T. Sattelmayer, “Simulation of a micro turbine’s dynamic
789 behavior in a biomass incineration power plant based on the Pebble Heater technology,” in
790 *Proceedings of the ASME Turbo Expo*, vol. 5, pp. 93–102, Orlando, Fla, USA, June 2009.
- 791 21. D.Aquaro and M. Pieve, High temperature heat exchangers for power plants: Performance of
792 advanced metallic recuperators, *AppliedThermal Engineering*, vol. 27, no. 2-3, pp. 389–400, 2007.
- 793 22. Amirante, R., & Tamburrano, P. (2014). High Temperature Gas-to-Gas Heat Exchanger Based on a Solid
794 Intermediate Medium. *Advances in Mechanical Engineering*, 6, 353586.
- 795 23. Catalano, L. A., Amirante, R., Tamburrano, P., & Copertino, S. (2012). Analysis of the complementary
796 energy losses of a high temperature gas to gas heat exchanger based on a solid intermediate medium.
797 *WIT Transactions on Engineering Sciences*, 75, 109-120.
- 798 24. Catalano, L. A., De Bellis, F., Amirante, R., & Rignanese, M. (2011). An immersed particle heat
799 exchanger for externally fired and heat recovery gas turbines. *Journal of Engineering for Gas Turbines*
800 *and Power*, 133(3) doi:10.1115/1.4002157.
- 801 25. ANSYS FLUENT Theory Guide 14.0. November 2011. Fluent Inc.
- 802 26. Cengel YA. Introduction to thermodynamics and heat transfer. New York: McGraw Hill Higher
803 Education Press; 2007. p. 253–62.
- 804 27. ModeFRONTIER™ User Manual. 2007. ESTECO s.r.l., AREA Science Park, Trieste, Italy.
805 <http://www.esteco.com> Barbarelli,S., Amelio, M., Castiglione, T., Florio, G., Scornaienchi, N. M.,
806 Cutrupi, A., & Zupone, G. L. (2014). Analysis of the equilibrium conditions of a double rotor turbine
807 prototype designed for the exploitation of the tidal currents. *Energy Conversion and Management*,
808 87, 1124-1133.
- 809 28. Amirante, R., Catalano, L. A., Poloni, C., & Tamburrano, P. (2014). Fluid-dynamic design optimization
810 of hydraulic proportional directional valves. *Engineering Optimization*, 46(10), 1295-1314.
- 811 29. Amirante, R. & Tamburrano, P. (2016). Tangential inlet cyclone separators with low solid loading:
812 Design by means of 3D fluid dynamic optimization. *Engineering Computations*, 33(7), 2090-2116.

813
814 **Acknowledgments**

815 The research presented in this work is funded by “Fondo di Sviluppo e Coesione 2007-2013 – APQ
816 Ricerca Regione Puglia, Programma regionale a sostegno della specializzazione intelligente e della
817 sostenibilità sociale ed ambientale - FutureInResearch”.
818