



Politecnico
di Bari

Repository Istituzionale dei Prodotti della Ricerca del Politecnico di Bari

Effects of dust on photovoltaic measurements: A comparative study

This is a pre-print of the following article

Original Citation:

Effects of dust on photovoltaic measurements: A comparative study / Lay-Ekuakille, A.; Ciaccioli, A.; Griffo, G.; Visconti, P.; Andria, G.. - In: MEASUREMENT. - ISSN 0263-2241. - ELETTRONICO. - 113:(2018), pp. 181-188.
[10.1016/j.measurement.2017.06.025]

Availability:

This version is available at <http://hdl.handle.net/11589/117436> since: 2022-06-10

Published version

DOI:10.1016/j.measurement.2017.06.025

Publisher:

Terms of use:

(Article begins on next page)

Effects of dust on photovoltaic measurements: A comparative study

A. Lay-Ekuakille ^a, A. Ciaccioli ^a, G. Griffo ^a, P. Visconti ^a, G. Andria ^b

^aDepartment of Innovation Engineering, University of Salento, Lecce, Italy

^bDepartment of Electrical and Information Engineering, Polytechnic of Bari, Bari, Italy

A B S T R A C T

Keywords:

Photovoltaic measurements
Dust
Solar radiation
MPPT
Solar energy
Efficiency
CdTe module
Pollution

Installation of renewal energy plant is a vital question for safeguarding cities and human agglomerations against pollution and helping them in the effort to save conventional energy contribution. As it is a wide-spread issue, PV plants can be located everywhere even in a severe conditions on the proviso that no external depositions, covering and coating the solar module, can alter the photovoltaic efficiency. To solve the problem, practically speaking, diverse solutions are envisaged and among them there is a continuous cleaning of dust by means of water and special liquids. The research proposes a modelling of the effect of dust on efficiency using experimental measurements provided through MPPT (maximum power point tracker) installed in the measuring architecture. Dust covering the PV module reduces the solar irradiance affecting the energy conversion. A comparison has been performed between a clean PV module under MPPT variations and another one of the same technology (CdTe, cadmium telluride) with dust. Both acquisitions have been carried out simultaneously for around one month. Both measurement campaigns agree with the scientific literature.

1. Introduction

Thin-film CdTe PV module is generally used in area where the interest is to capture diffuse radiation of sunlight. CdTe is an active material having the following properties:

- It has an energy gap of 1.45 eV necessary to capture solar radiation;
- A very light absorption is denoted since its energy gap is direct;
- Low cost production thanks to developed deposition techniques;
- Strong bonding leads to an extremely high chemical and thermal stability.

By using the most advanced processes, numerous film-fabrication techniques have been used to deposit CdTe for moderate- to high-efficiency solar cells, and for some reviews of these we suggest the Handbook of Photovoltaic Science [1]; the photovoltaic behavior of CdTe/CdS solar cells having conversion efficiency from ~10 to ~16% has been remarkably independent of the CdTe deposition technique.

The current commercial efficiency is around 13% while the new record is approximately 18.7%. However, the main advantages of this technology are: reliable production of energy thanks to the high thermal tolerance and high performance, even in the case

of diffuse sunlight. As we may know, there are different methods for determining the energy production, hence the efficiency. One of the most immediate and affordable methods is the matrix method but it is difficult to apply it for thin-film CdTe module. However some positive findings have been developed [2] that allow us today to use it for this kind of module. As any photovoltaic module, thin-film CdTe module is affected by dust covering its surface. Not only dust but all depositions can negatively impact on the electrical characteristics of the module. The quality of deposition has diverse impacts because dust is a simple covering of surface that can be removed by water but in case of persistent deposition due to heavy materials, that are the consequences of hydrocarbons and solvents [3], in this case the effects can be irreversible on the module not only as a decrease of the quantity of sunlight to be converted in electrical energy but also damages on the PV glass and electrical connections. For this latter case, a localization of a PV plant becomes questionable since the cost of the disposal of these materials will become very high for the owner. In an analytical viewpoint, dust and other materials which are deposited on PV modules could be the result of three kinds of deposition [4–6]: dry, humid (wet) and shadow.

1.1. Dry deposition

With this acceptance we intend all processes by means of which gas and particles present in the atmosphere are transferred to ground surface, either on objects (buildings and others) or living

beings (vegetation, animals, humans). The term “dry” refers as to mechanisms that determine the transport of gas and particles to surface, and not to the nature of the surface. The intuitive and common concept used to describe the dry deposition of a certain micropollutant, gaseous or particulate, is the deposition speed v_d defined as [7]

$$v_d = \frac{F}{c(z)} \quad (1)$$

where

F is the flow of removed pollutant per unit of surface [$\text{g m}^{-2} \text{sec}^{-1}$].

$c(z)$ stands for pollutant concentration near the ground [g m^{-3}].

v_d speed of deposition [ms^{-1}].

The dry deposition of atmospheric gas and particulates takes place in two distinct steps: first, transferring of micropollutants to a surface, while the second step regards the retention of micropollutants on such surface.

1.2. Wet deposition

Wet deposition includes all processes through which atmospheric contaminants are transported on soil in diverse forms of precipitations (rains, snows, fogs). Hence, wet deposition concerns the interaction of pollutants with atmospheric water and it encompasses chemical reactions in aqueous phase, beyond the process of precipitation.

Let $Q(t)$ be the quantity of pollutant at instant t , after a range dt , we will have

$$Q(t + dt) = Q(t)e^{l_w(t)dt} \quad (2)$$

where $l_w(t)$ is the coefficient of washout and it can be expressed in terms of precipitation intensity, $P(t)$ [in mm/h], that is

$$l_w(t) = l_{w0}P(t)^a \quad (3)$$

in which $l_{w0}(t)$ is a constant that depends upon the type of pollutant and a is an exponent that varies from 0.75 up to 1 [8].

1.3. Shadow deposition

There is a further mechanism that can be qualitatively defined as “intermediate” between the previous ones. It is due to droplets of cloud or fog, alias shadow deposition [9,10]. This phenomenon has the characteristics of wet deposition, because clouds and fogs are constituted by droplets of liquid water. Unlike elements of precipitation (droplets of rain, snowflakes, beans of hailstorm), which deposition is essentially produced by gravitational sedimentation. Pollutants encompassed in droplets are in contact with surfaces, which they can interact with. The balance of shadow deposition of a pollutant i will be composed by two terms: the first is related to the volume of water (droplets) deposited per unit of time and surface and the second dealing with the concentration of pollutant i within the deposited droplets:

$$d_i = d_{H_2O}c_i \quad (4)$$

where

d_{H_2O} is the volume of water deposited [$\text{l m}^{-2} \text{h}$]

c_i is the concentration of i -th pollutant inside droplets [g l^{-1}]

d_i is the total quantity of i -th pollutant removed for shadow deposition [$\text{g m}^{-2} \text{h}$]

The terms d_{H_2O} is not directly determined but it is necessary to calculate it by knowing the dimensional distribution of droplets. A further difficulty derived from the circumstance according to which the concentration c_i cannot be constant in droplets of diverse dimensions. The term d_{H_2O} can be split in two parts,

$$d_{H_2O} = LWC v_{d_{H_2O}} \quad (5)$$

where

LCW (*Liquid Water Content*) is the content of liquid water in the cloud or fog, summation of volumes of single droplets suspended in air per unit of volume [$\text{l m}^{-3} \text{h}$]. $v_{d_{H_2O}}$ is the speed of deposition of droplets [mm^{-1}]. In concise terms, the elements that concur to determine the shadow deposition are the followings:

- content of liquid water within the cloud/fog;
- speed of deposition of droplets;
- concentration of pollutants in the droplets;
- frequency of clouds and fogs.

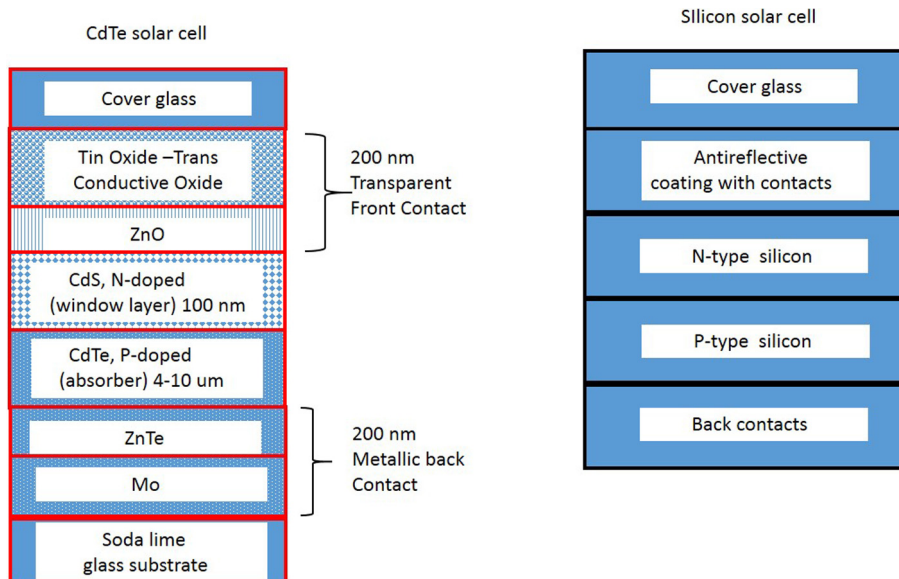

Fig. 1. Cross section of CdTe and silicon solar cells.

As a practical example, Fig. 1 shows two different cross-sections of CdTe and silicon PV cells respectively. Above all, a protective stratum of glass is represented to avoid direct contact between atmosphere and cell/panel. Glass can be “corroded” by hazardous material deposition from dangerous emissions, mostly containing metals. However it is almost an exceptional case since glass is resistant to the high majority of chemical elements. In the event of “corrosion”, the glass should certainly have a fabrication defect. However, deposition can penetrate the PV cell by means of the contour of the panel since it is generally protected by a metallic tape for small plants but it is not mounted for normal big plants in order to put panels in a juxtaposed way.

The aforementioned considerations yield to a great concern when managing photovoltaic plants, especially in some sites like deserts, industrial areas, areas with high deposition rates, etc. . . Many company installing PV modules use special ecological liquid cleaners [11–13] to remove deposition, hence, damages on modules since deposition can bring to a decrease of produced energy up to 50%. This kind of percentage is an economic loss for users.

2. Scenario and context

The experimental facility is located on the roof of the Department of Innovation Engineering according to GPS co-ordinates (40.335273, 18.114991). The context, as illustrated in Fig. 2, displays the presence of infrastructures capable of producing dusts at short distances but we have also depositions from saharian aerosols, pollutants from industrial plants and in some cases saltiness. Quarries, close to the plant, have a particular influence, because they use plants for crushing limestone for different granular dimensions. Even if plants are covered according to current legislation, wind and lorry traffic are source of dust diffusion and air-transportation. The other sources are buildings and civil infrastructures under construction. We have chosen to perform the proposed analysis on thin-film CdTe PV modules since their efficiency is lower than that related to mono/polycrystalline modules for concentrated sunlight.

The thin-film CdTe PV modules are depicted in Fig. 3 and they are connected to MPPT (maximum power point tracking) system [14] and the acquisition architecture is illustrated in [15] and sum-

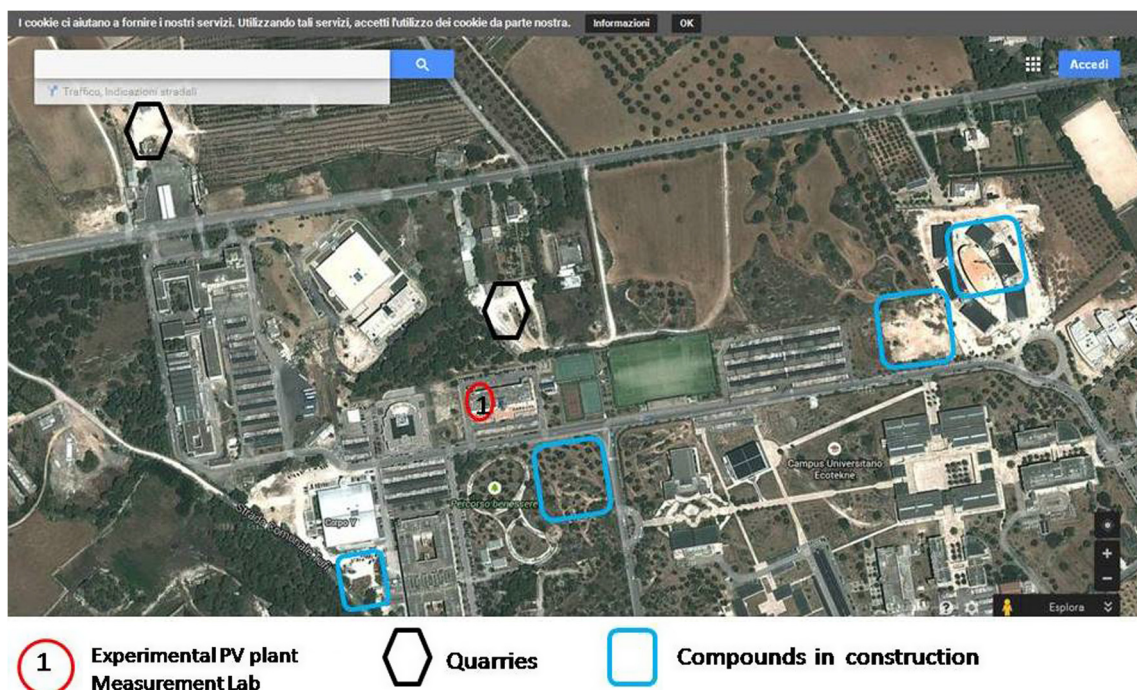

Fig. 2. Scenario and context of experimental activities within Lecce campus.



Fig. 3. View of thin-film CdTe PV modules located on the Dept lab roof.

marized in the next section. A dedicated software is used to process data including atmospheric conditions as wind, humidity, solar radiation, etc. . . These conditions are monitored by dedicated instrumentation located on the roof.

3. Experimental architectures and data acquisition

The experimental architecture consists in different units, starting from monitoring devices: the pyranometer CM11 [16] for measuring solar radiation, direct solar radiation and diffused one, a weather station WS3650 [17] able to transmit via wireless system data to the computer station. The general architecture is illustrated in Fig. 4. The PV module (75 w, K-275, First Solar), based on thin-film CdTe, is used for this purpose which parameters are read and stored by means of a dedicated software and computer (see Fig. 5). However, before transmitting data to computer, they are first processed and stored by a MPPT 3000 [18] in order to trace and find the requested point in accordance with the plots of Fig. 6 using the GUI illustrated in Fig. 7. A datalogger, agilent 34,970 [19], is connected to the computer, receiving data from MPPT and the other monitoring devices and apparatuses.

The acquisition system is a 24 h complex system able to perform measurements for all PV modules installed on the roof of the Dept lab. To avoid data missing and mismatch, all the system is connected to an UPS (uninterruptible power system). Every two minutes we have an acquisition of PV module data, for instance, power, voltage, current, MPPT resistances and operating parameters, etc. . . The MPPT system, watching Fig. 8, contains power unit and controlling parts. The MPPT system must be always connected to a load resistance. This latter has an impact on data

recovery. To allow better variation of MPPT resistance, an additional and external resistance has been included. The optimal load resistance of this MPPT ranges from 18 up to 22 ohms, especially for south italian regions.

Any value out this range can change the performance in calculating energy production and as it is outlined in previous sections, the main scope is to realize a system able to understand the effect



Fig. 5. Measurement GUI for PV module acquisition.

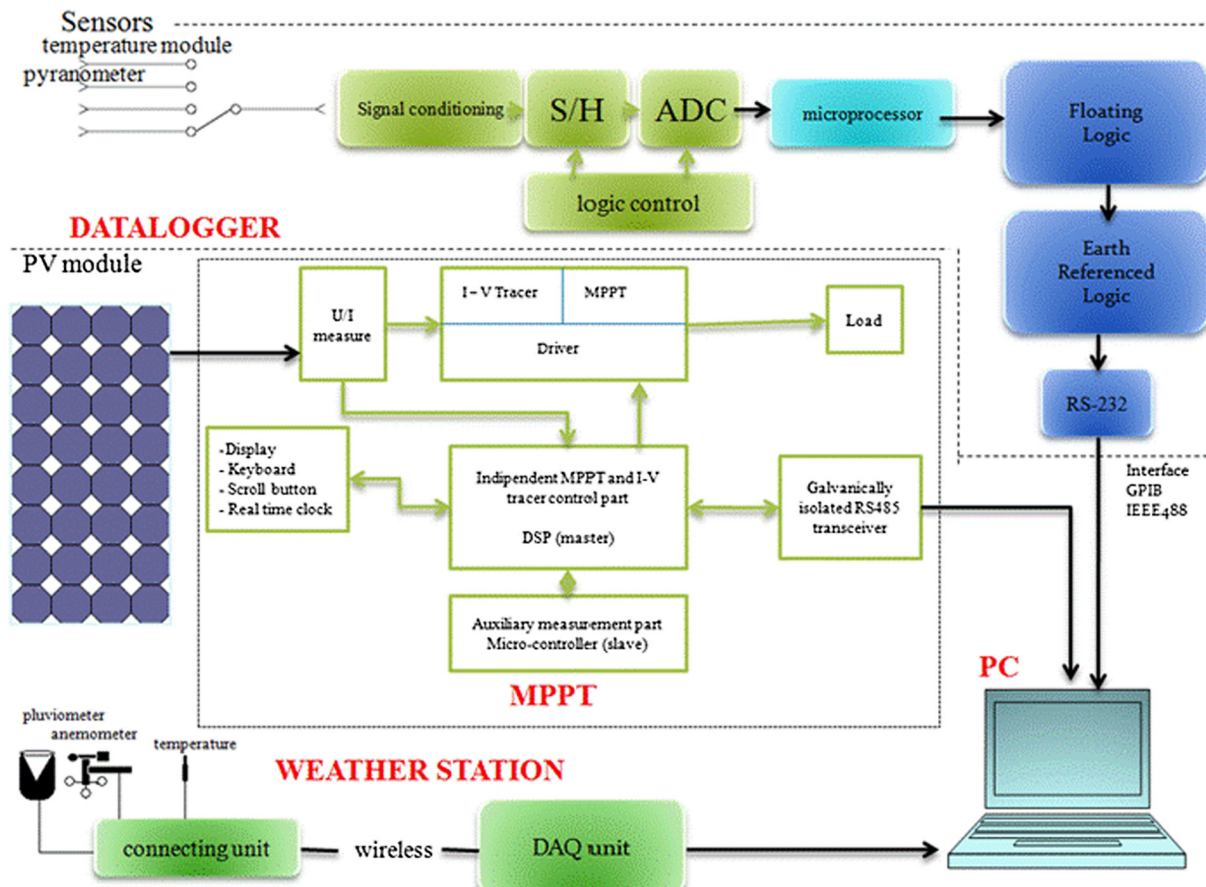

Fig. 4. Measurement architecture system.

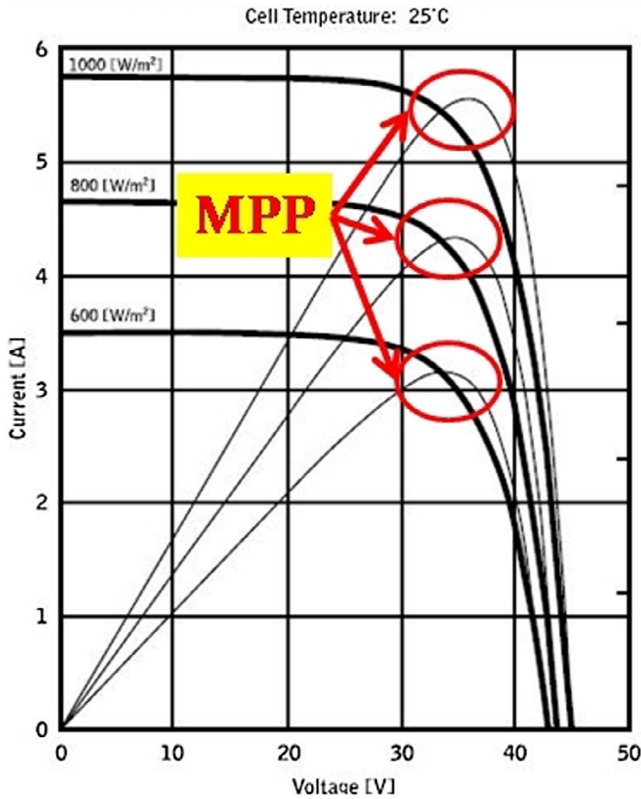

Fig. 6. MPPT plots.

of shadow (covering film) due to dust in connection with the energy production. This kind of approach, using only a MPPT is very interesting since it can be performed without using an actual film of dust even if the experiment requires dust on the PV module.

4. Results

The experiments have been conducted from the beginning of may 2014 up to mid June 2014. The chosen period is very significant in Lecce since may and June are the transitional month from spring to summer with interesting diffuse radiation earlier in the morning and appropriate quantity of wind [20]. Two PV modules based on thin-film CdTe have been used with the architecture of previous section. As we may know, the general formulation of the efficiency of a PV module is given by

$$\eta = \frac{P_{out}}{P_{in}} = \frac{V_{oc} I_{sc} FF}{EA_c} \quad (6)$$

where

- V_{oc} is the open-circuit voltage;
- I_{sc} is the short-circuit current;
- FF is the fill factor;
- E is the incident radiation flux;
- A_c is the area of collector.

Given the experimental plant above described and the PV module, taking into account the efficiency depicted in Eq. (6), the only quantities that can change are V_{oc} and I_{sc} . The first is the open-circuit voltage and the latter is the short-circuit current. Both quantities can be influenced by the dust film deposited on the PV module.

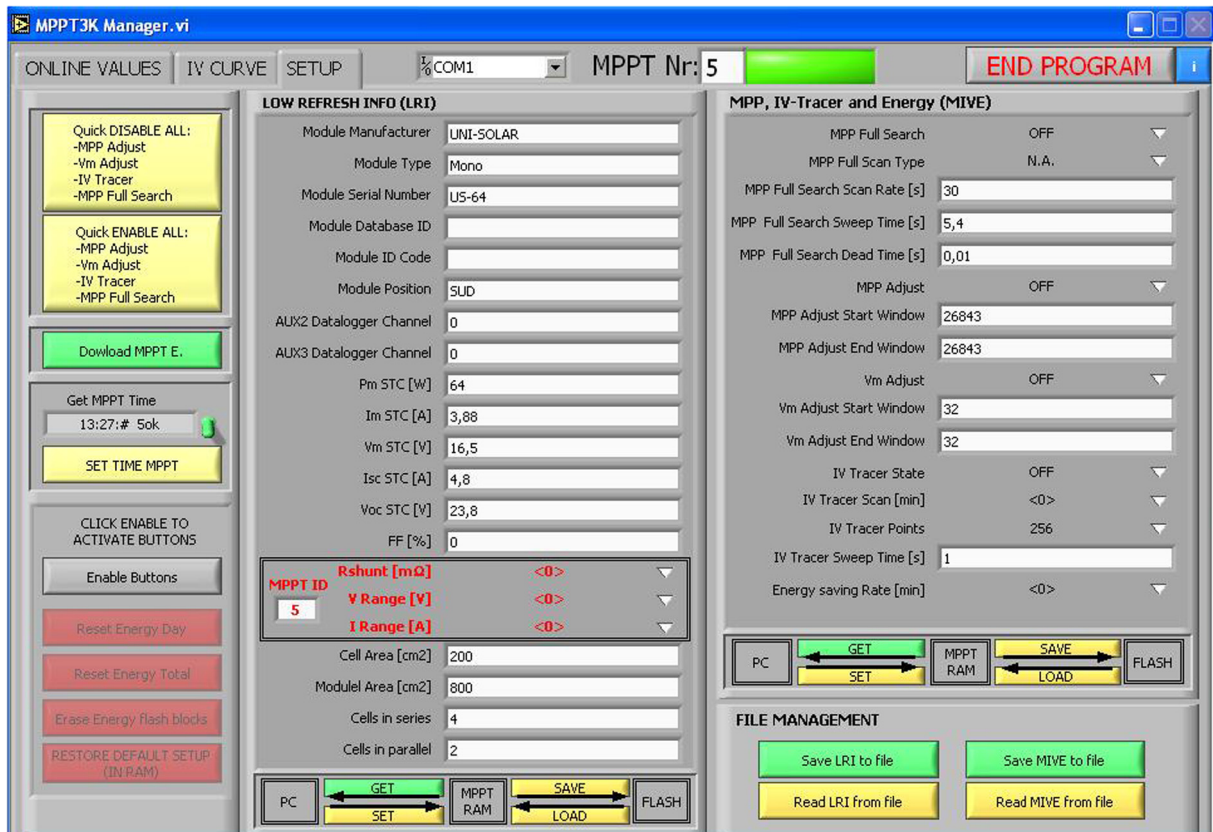

Fig. 7. MPPT GUI.

Fig. 9 describes the power produced by the same CdTe in normal conditions, same period, without dust on the module. The experiment with the introduction of additional resistance yields to results expressed in Fig. 10. Four resistance values have been used, that is, $8\ \Omega$, $10\ \Omega$, $23.5\ \Omega$ and $47\ \Omega$. As we have sentenced, the optimal range of MPPT load resistance is 18 ohms up to 22 ohms (for the considered location) even if the operating load resistance range is from $18\ \Omega$ up to $47\ \Omega$. The choice of resistance in such interval depends upon the climate where the CdTe module is located. Fig. 10 ($23.5\ \Omega$) is similar to that of Fig. 9 and there is a uniform distribution with the increasing of solar radiation G expressed in W/m^2 . But there are small abnormalities at $35\text{--}39\ ^\circ C$ versus $60\text{--}130\ W/m^2$; in Fig. 9, there is no energy production while in Fig. 10 there is, even small. That is due to the overcoming

of the optimal resistance for $1.5\ \Omega$. All figures illustrate the electrical power (vertical axis), and in the horizontal plane we have temperature vs solar radiation.

Remembering that below $18\ \Omega$ as MPPT load resistance, there is an increase of current that could be dangerous for the working procedures of the system. In Fig. 10 we see the power production for $10\ \Omega$ and $8\ \Omega$. The daily average power production is shown in Fig. 11. From this last figure we report the power in function of the days of measurements. With $5.95\ \Omega \pm 10\%$, we have a produced power ($103\ W$) greater than the $75\ W$ nameplate power of the PV module. This is apparently a nonsense but it is not; going down with the value of resistance, we used resistances with uncertainty of $10\ \Omega$. The theoretical maximum power of the used PV module is around $95\ W$, plus 10% of resistance uncertainty, this brings to the

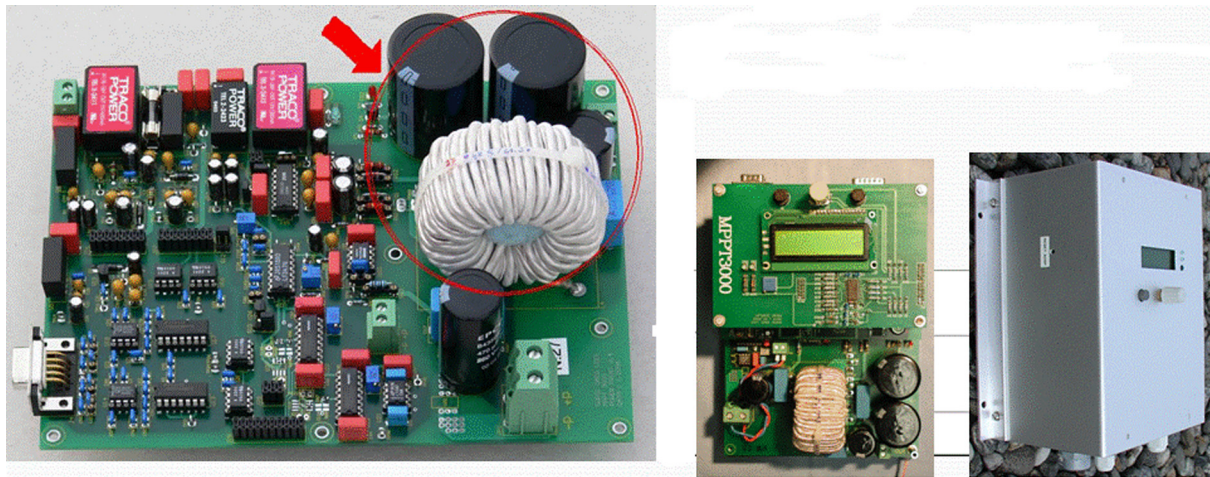

Fig. 8. MPPT 3000 inner part. The red arrow indicates power unit.

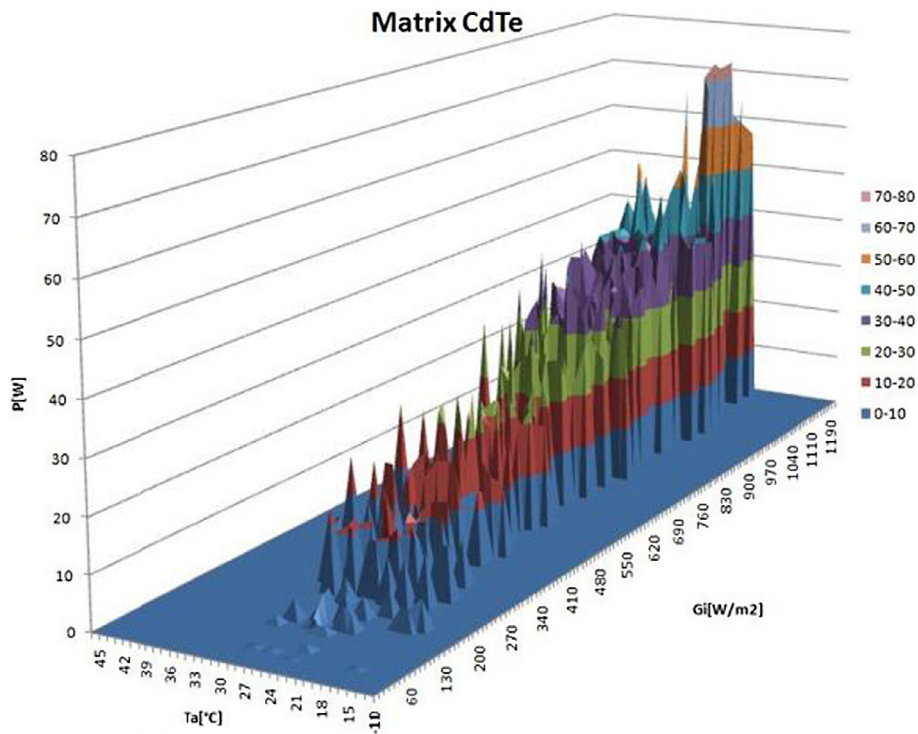

Fig. 9. Normal experimental CdTe power matrix.

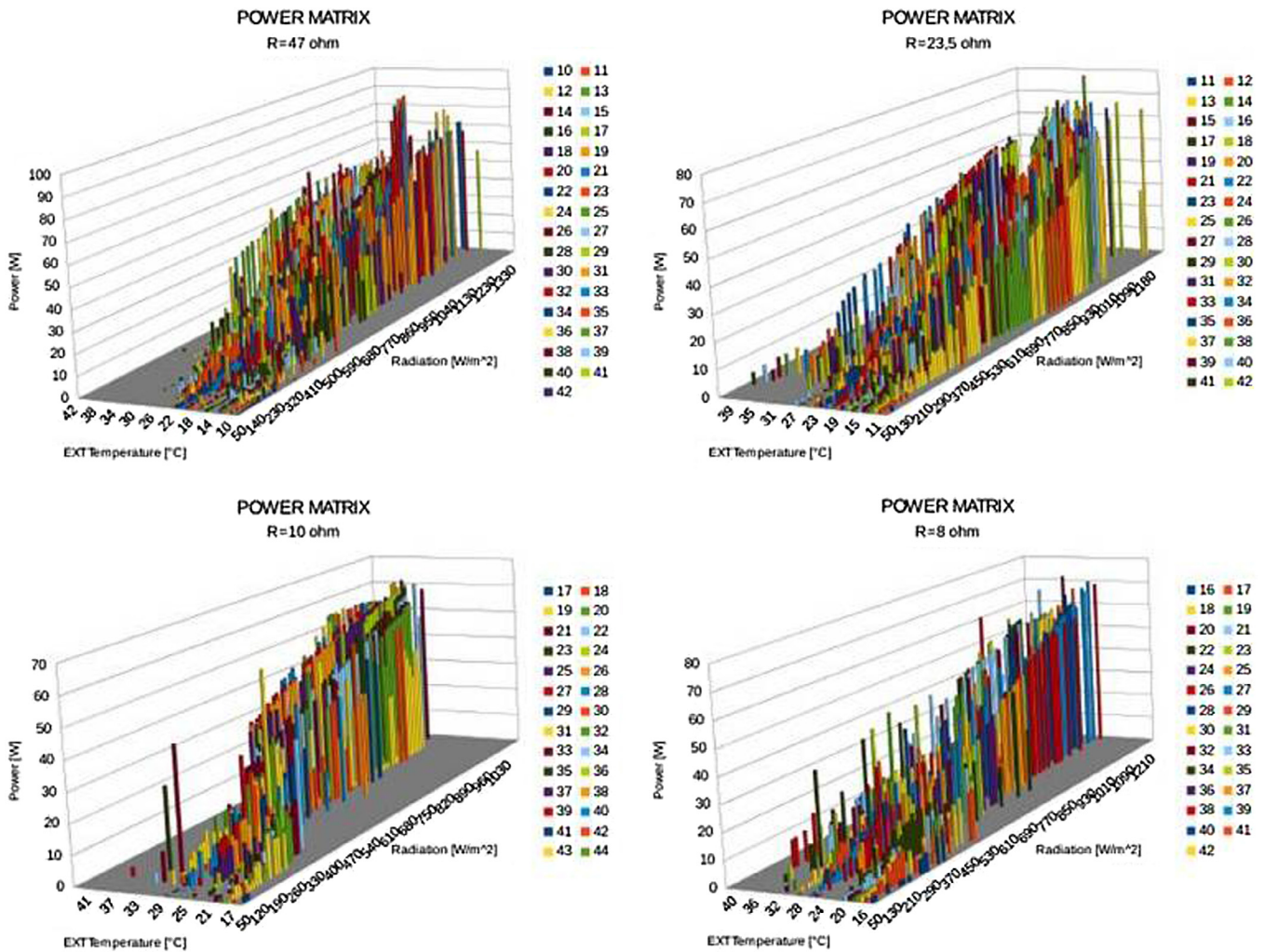

Fig. 10. Dust-based experimental CdTe power with matrix method varying R.

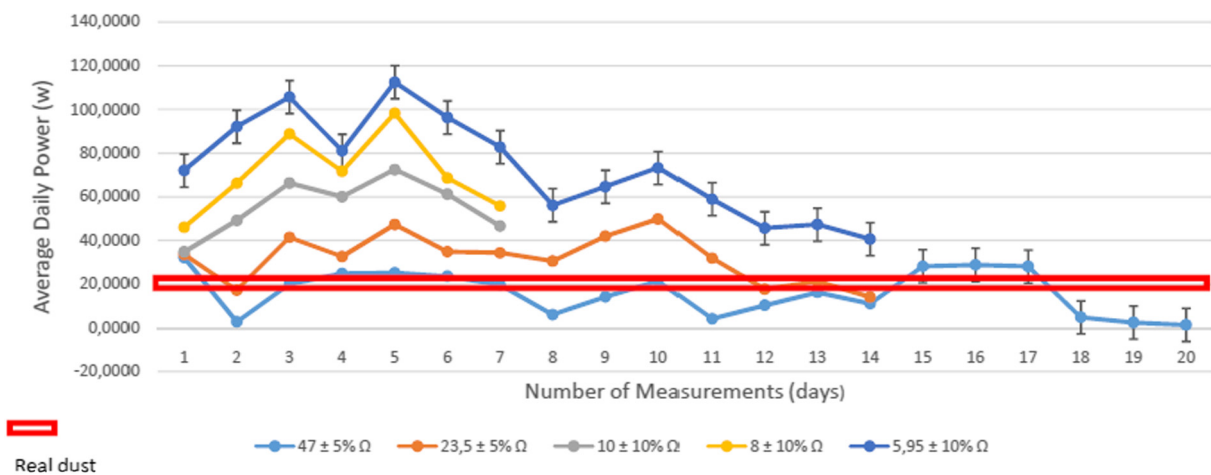

Fig. 11. Experimental comparison between real dust presence and MPPT resistance variation.

determined power of 103 W. This is also true because of the increasing of current due to the decreasing of the resistance. According to the experimental data the decrease of power has been mainly pointed out with the MPPT load resistance of $47\ \Omega \pm 5\%$ that corresponds to 20 w. That is true since the PV module, which

investigations have been conducted on, has not been voluntarily cleaned since six years and when it rains the module is generally covered. This aspect falls within the research topic regarding ageing of PV module. Dust operates as shadow on PV module as it is illustrated in Fig. 12. The captions sentence the following: with

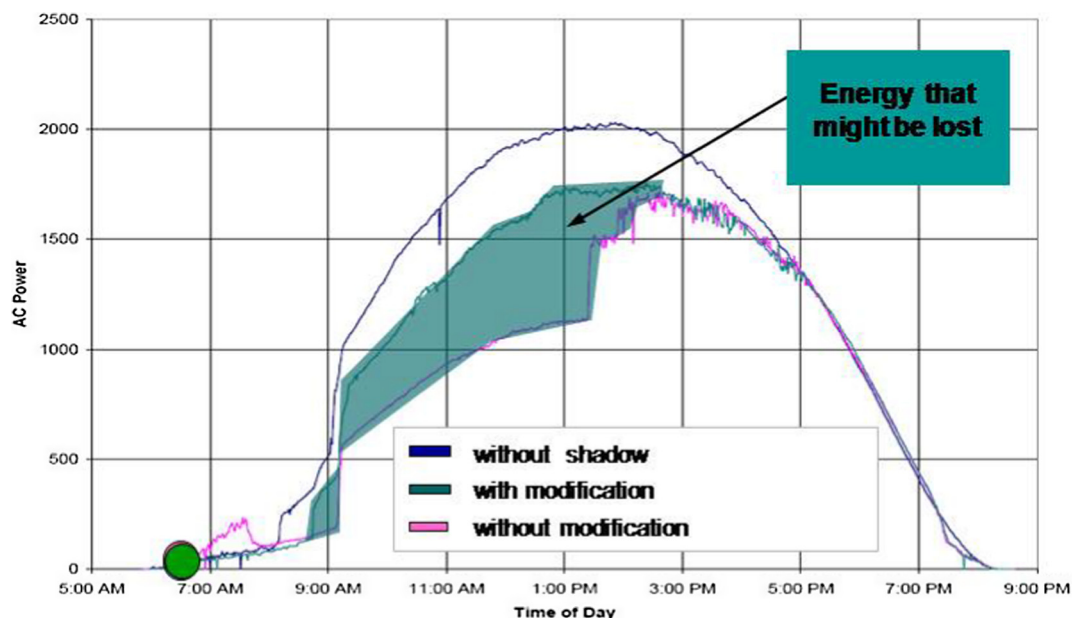

Fig. 12. Energy loss for shadow on PV module.

modification stands for introduction of resistance. Fig. 12 is an alias of Fig. 11 because it illustrates, in another manner, the impact of shadow, intended as long time dust film on the PV module.

5. Final outlook

With this paper, we have investigated on the possibility of performing modelling and experimental trials for retrieving the interested parameters able to allow a further simulation of dusts and pollutants deposition [21,22] on thin-film CdTe PV modules. While the results of this research can be expected for mono/polycrystalline PV modules, it is not for thin-film CdTe PV modules in the climate conditions of the location. As we may know, this kind of PV module is generally used where the diffuse radiation is very important as in northern areas of the world, for example from Germany/Belgium (Europe) while in southern Europe, mono/polycrystalline PV modules are generally used. After many years, the deposition becomes very hard to remove because of crystallization, that is, the film of dusts and pollutants [23] becomes like a caramel or fatness. So, a decrease from 75 w down to 20 w after six years of exposure to contaminants is matter of reflection for managing PV plants in dirty atmospheres. For verifying the state of PV modules before and after cleaning, onsite inspection systems and devices are needed by means of special sensing systems [24–26] capable of detecting eventual holes and stripes.

References

- [1] Handbook of Photovoltaic Science and Engineering (Second Edition Edited by Antonio Luque Instituto de Energia Solar, Universidad Politecnica de Madrid, Spain and Steven Hegedus Institute of Energy Conversion, University of Delaware, USA, A John Wiley and Sons, Ltd., Publication), December 2010.
- [2] A. Lay-Ekuakille, A. Arnesano, P. Vergallo, Thin-film-based CdTe PV module characterization: measurements and energy prediction improvement, *Rev. Sci. Instrum.* 84 (2013) 15114–15117.
- [3] L. Piper, A. Lay-Ekuakille, P. Vergallo, V. Pelillo, A Novel Pseudo-Stationary Modeling of Pollutant Measurement Prediction from Industrial Emissions, XX IMEKO World Congress Metrology for Green Growth September 9-14, 2012, Busan, Republic of Korea.
- [4] A. Sara Janhäll, Review on urban vegetation and particle air pollution – Deposition and dispersion, vol. 105, 2015, pp. 130–137.
- [5] A. Lay-Ekuakille, A. Trotta, Predicting VOC concentration measurements: cognitive approach for sensor networks, *IEEE Sens. J.* 11 (11) (2011), pp.3923–3030.
- [6] A. Lay-Ekuakille, P. Vergallo, N.I. Giannoccaro, A. Massaro, D. Caratelli, Prediction and Validation of Outcomes from Air Monitoring Sensors and Networks of Sensors, V International Conference on Sensing Technology, ICST2011, Nov 28th – Dec 1st 2011, Palmerston North, New Zealand
- [7] A.M. Taiwo, R.M. Harrison, Z. Shi, A review of receptor modelling of industrially emitted particulate matter, *Atmos. Environ.* 97 (November 2014) 109–120.
- [8] E. Jurado et al., Wet Deposition of Persistent Organic Pollutants to the Global Oceans, *Environ. Sci. Technol.* 39 (8) (2005) 2426–2435.
- [9] L. Morselli, Acid deposition - precursors, interaction with Environment and Materials, Maggioni Editore, 1991.
- [10] A. Lay-Ekuakille, I. Palamara, D. Caratelli, F.C. Morabito, Experimental IR Measurements for Hydrocarbon Pollutant Determination in Subterranean Waters, *Review of Scientific Instruments*, Vol. 84, pp. 015103-1 (8 pages) 2013.
- [11] <http://www.solar-panel-cleaners.com/how-clean-solar-panels/>.
- [12] <http://www.energymatters.com.au/panels-modules/cleaning-solar-panels/>.
- [13] P. Vergallo, A. Lay-Ekuakille, A. Ciaccioli, G. Griffo, Compensating environmental influencing factors for characterizing PV module efficiency, in: 5th Imeko TC19 Environmental Measurements, 23-24 september 2014, Chemnitz, Germany.
- [14] A. Lay Ekuakille, G. Vendramin, A. Fedele, L. Vasanelli, A. Trotta, PV Maximum Power Point Tracking Through Pyranometric Sensor: Modelling and Characterization, *Int. J. Smart Sens. Intell. Syst.* 1 (3) (2008) 659–678.
- [15] C. Calo', A. Lay-Ekuakille, P. Vergallo, C. Chiffi, A. Trotta, A. Fasanella, A.M. Fasanella, Measurements and Characterization of Photovoltaic Modules for Tolerance Verification, *IJMTIE, International Journal of Measurement Technologies and Instrumentation Engineering*, vol. 1 no. 2, , april-july 2011, pp. 73–83.
- [16] <http://www.delta-t.co.uk>
- [17] <http://www.weather-station-products.co.uk/lacrosse-weather-station-ws3650>
- [18] http://www.supsi.ch/isaac/fotovoltaico/sistemi_pv/prodotti/mppt-3000.html
- [19] <http://www.keysight.com/en/pd-1000001313:epsg:pro-pn-34970A/data-acquisition>
- [20] P. Vergallo, A. Lay-Ekuakille, Spectral analysis of wind profiler signal for environment monitoring, in: *IEEE I2MTC*, May 13-16, 2012, Graz, Austria.
- [21] V. Pelillo, L. Piper, A. Lay-Ekuakille, A. Lanzolla, G. Andria, R. Morello, Geostatistical approach for validating contaminated soil measurements, *Measurement* 47 (1) (2013) 1016–1023.
- [22] A. Sayyah, M.N. Horenstein, M.K. Mazumder, Yield loss of photovoltaic panels caused by depositions, *Sol. Energy* 09 (107) (2014) 576–604.
- [23] J.K. Kaldellis, P. Fragos, M. Kapsali, Systematic experimental study of the pollution deposition impact on the energy yield of photovoltaic installations, vol. 36, n. 10, 2011, pp. 2717–2724.
- [24] N.I. Giannoccaro, A. Massaro, L. Spedicato, A. Lay-Ekuakille, Detection analysis of small notches damages using a new tactile optical device, *IEEE/ASME Trans. Mechatron.* 20 (1) (2015) 313–320.
- [25] N.I. Giannoccaro, A. Massaro, L. Spedicato, A. Lay-Ekuakille, M. Missori, M.A. Malvindi, Characterization of an innovative like-eye sensor for feature detection and robot sensing measurement, *Measurement* 55 (2014) 153–167.
- [26] N.I. Giannoccaro, L. Spedicato, A. Lay-Ekuakille, A. Massaro, "Automatic Diagnostic by Using a New Optical Sensor", 2nd IEEE Metroaerospace 2015, June 4-5, 2015, Benevento, Italy