



Politecnico  
di Bari

Repository Istituzionale dei Prodotti della Ricerca del Politecnico di Bari

A simulation and control model for building energy management

This is a post print of the following article

*Original Citation:*

A simulation and control model for building energy management / Fanti, Maria Pia; Mangini, Agostino Marcello; Roccotelli, Michele. - In: CONTROL ENGINEERING PRACTICE. - ISSN 0967-0661. - STAMPA. - 72:(2018), pp. 192-205. [10.1016/j.conengprac.2017.11.010]

*Availability:*

This version is available at <http://hdl.handle.net/11589/123077> since: 2021-03-05

*Published version*

DOI:10.1016/j.conengprac.2017.11.010

Publisher:

*Terms of use:*

(Article begins on next page)

# A Simulation and Control Model for Building Energy Management

Maria Pia Fanti<sup>a</sup>, Agostino Marcello Mangini<sup>a</sup>, Michele Roccotelli<sup>a</sup>

<sup>a</sup>*Department of Electrical and Information Engineering of the Polytechnic of Bari, Via Orabona 4, 70125 Bari, Italy fax: +390805963410, email: {mariapia.fanti, agostinomarcello.mangini, michele.roccotelli}@poliba.it*

---

## Abstract

This paper deals with the energy consumption management problem in buildings by modelling and controlling the main electric appliances. Renewable energies are taken into account by considering the production schedules of both wind and solar sources. Each appliance is described by modular mathematical models by means of the Matlab/Simulink software. A simulator is designed that allows modelling the load energy consumptions and helps to recognize how they contribute to peak demand. Moreover, a controller to manage the load usage is designed in a Petri Net framework. In the proposed control strategy, the comfort conditions are respected for each appliances on the basis of the user preferences. Finally, a real case study validates and tests the effectiveness of the simulator applied to the considered appliances.

*Keywords:* Building energy management, Appliance control, Simulation, Petri Net, Matlab/Simulink.

---

## 1. Introduction

One of the main problems to be faced in the near future is the increase of the power demand. Indeed, in the next decade, power demand is estimated to rise by 19% and the existing infrastructures can increase their productivity by only 6% [1]. In the last years, the building energy consumption amounts to around 30% of all energy consumed in advanced countries. In this context, it is important to encourage the building and business owners to adopt new technologies in order to reduce the demand for the electric grid [2]. The literature is poor in accurate real-time simulation and control tools

about the Building Energy Management (BEM), even if the building energy consumption represents much of the total energy consumed in advanced countries.

This paper proposes a detailed model devoted to simulate the building appliance energy consumptions and control the loads usage by a strategy that takes in account both the total building energy consumptions and the respect of the comfort conditions. The aim is twofold: i) provide a simulation framework in order to sensitize the building and business owners to use new Information and Communication Technology (ICT) tools to reduce the demand on the electric grid; ii) propose a control logic forcing the building appliances to follow a demand reduction strategy. In particular, the controller is modeled in a Discrete Event System framework described by a Petri Net (PN). Moreover, the control strategy is applied in a simulation environment describing the dynamics of the following loads: Heating Ventilation and Air Conditioning (HVAC) system, water heater, dishwasher, washing machine, refrigerator, freezer, oven, iron, TV, PC, dimmable lamps and renewable sources such as photovoltaic and eolic. In particular, the demand reduction strategy is implemented by a Building Energy Management System (BEMS) and aims at monitoring the real-time building energy consumptions in order to:

- avoid the overcoming of power provided by the electric grid;
- respect the user comfort by an intelligent power reduction based on a priority list of the electric loads.

The use of the priority criteria in order to manage the domestic electric loads are introduced in the related literature by [3].

Moreover, a discrete-event formalism modelling the system dynamics is presented for testing alternative priority lists and capturing emerging criticalities. To this aim, the proposed PN model is both a mathematical tool for process simulation and a graphical tool [4] for allowing a modular design of discrete event system controller. Furthermore, the PN can be automatically converted into commonly used language for Programmable Logical Controllers (PLCs) [5].

This paper is organized as follows. Section 2 reviews the literature on BEM, while Section 3 presents the simulation framework and its components. Section 4 describes in detail the loads model while Section 5 shows the con-

troller model. Moreover, Section 6 introduces a case study and analyses the simulation results. Finally, Section 7 draws the conclusions.

## 2. Literature Review

Recent researches focus on energy management problems and the proposed technological solutions can be divided in two main categories [6], [7]

- predictive energy management;
- real time control algorithms.

The predictive energy management research proposes model predictive control methods which incorporate both forecasts and updated information in order to obtain an optimal appliance scheduling. Such models mainly aims at minimizing the building energy costs [8–12].

Chen *et al.* [8] present an appliance scheduling scheme for residential BEM controllers in order to minimize the energy costs. Finite-horizon scheduling optimization problems are formulated to exploit operational flexibilities of thermal and non-thermal appliances using a model predictive control method which incorporates both forecasts and newly updated information.

In [9] the authors address the problem of finding the optimal control action for heating, cooling, ventilation, blind positioning, electrical lighting, humidity. The proposed appliance scheduling is determined in such a way that the temperature,  $CO_2$  and luminance levels in building zones stay within the desired comfort ranges and the physical and economic constraints are satisfied.

Moreover, papers [10–12] solve an optimal stochastic control problem for the home energy management system. Indeed, Li *et al.* [10] develop an integrative demand response strategy based on two stage stochastic programming model that considers the energy usage of critical appliances essentially stochastic. The optimization objective is to minimize a customer electricity cost. In addition, [11] models the building energy system as pure stochastic differential equation models, and then the authors follow the completing square technique to solve the stochastic home energy management problem. Finally, in [12] a stochastic dynamic programming framework for the optimal energy management of a smart home with plug-in electric vehicle energy storage is proposed.

The second research category develops optimum operation scheduling models of domestic electric appliances using integer linear programming and simulation frameworks. The goal is to reduce peak power, energy costs taking in account the customer comfort range [13–22].

In particular, papers [13–16] propose intelligent energy controller algorithms that efficiently manage energy consumption for both heating and cooling appliances. In [13] a distributed intelligent energy algorithm that minimizes energy use in the heating and cooling system within the home by taking into consideration occupant preferences is proposed. Li *et al.* [14] presents a computational experiment approach to develop and investigate demand response strategies for the HVAC system of a typical residential house. The authors use four different demand response algorithms: optimization, particle swarm optimization, heuristic method and an integrative computing platform that combines a home energy simulator and MATLAB together. Moreover, [15] considers a distributed and cooperative approach for coordinating the power demand of electric thermal systems while Zhang *et al.* [16] focuses on developing an interdisciplinary mechanism that combines machine learning, optimization, and data structure design to generate optimal demand response policies for HVAC systems.

Since the energy system of the future is expected to be composed of a large variety of ICT tools, recent works investigate the problem of controlling each typology of electric appliances. In particular, the energy systems may lately make use of new controllers and communication infrastructure and benefit from cyber-physical system advantages [23]. Moreover, the use of low-power narrowband power line communication can support home energy management systems with respect to the limits of wireless communication. Indeed, in an home framework it is difficult to communicate with all electric appliances for the presence of walls or obstacles. On the other hand, the use of narrowband power line communication greatly improves the packet success rate to the electric appliances [24].

Wang *et al.* [17] propose an agent-base model to evaluate the BEMS in residential demand response implementation. In particular, the BEMS intelligently controls household loads with association of smart meters. The proposed model can be considered as a test-bed to evaluate various demand response strategies and technologies.

Moreover, [18] presents a home energy management system that schedules the energy usage in a smart home in response to utility pricing signals. Yu and Dexter [19] propose a model-free method using reinforcement learning

scheme to tune a supervisory controller for a low-energy building system online.

In addition, Lai *et al.* [20] present a smart appliance management system to recognize electric appliances in home networks, which uses sensing devices that measure current to calculate the power consumption of the appliances. The paper is focused on the architecture to be designed for monitoring the electric appliances.

In this field Fanti *et al.* [25] propose a PN model to describe the behaviour of a controller that manages the home appliance in order to reduce the consumptions.

The authors of [22] investigate the possibility to support the development of home energy systems and residential micro grid concepts by simulations including detailed load models in order to improve the efficiency of the applied energy management strategy or control strategy.

In this context, Gudi *et al.* [1] propose an optimized operation of household appliances in a Demand-Side Management (DSM) based simulation tool. In particular, the main purpose of the authors is to illustrate customer-driven DSM operation, and evaluate an estimate for home electricity consumption while minimizing the customers cost. A binary Particle Swarm Optimization is used for optimizing the DSM operation. The consumption of appliances is deducted by data-sheets that report the energy consumption in steady state.

Moreover, [6] presents a novel algorithm based on adaptive scheduling to reduce energy during peak hours without affecting the comfort of occupants in a smart home. The proposed approach is described and applied to a realistic example simulated in MATLAB/Simulink framework.

On the other hand, Piloni *et al.* [21] analyse the issue of introducing adjustments in the appliances' scheduling during the user working period for energy cost savings. The authors propose a Quality of Experience aware smart home energy management system, which relies on the knowledge of the annoyance suffered by the users when the operations of appliances are changed with respect to the ideal users preferences.

### 2.1. Paper Contribution

In the related literature, simulation and control studies have paid less attention to the problem of appliances' scheduling operations. However, some works [6, 22] highlight the possibility of developing BEMSs by simulations. Moreover, the authors in [21] are aware that changing the appliance scheduling can be annoyance for the building occupants.

In this context, this paper proposes a simulation and control model for BEMS in order to monitor and perform the loads real-time control. The control procedure allows the aggregated power consumption does not exceed the available power profile and avoid curtailment, by managing the appliances according to the comfort preferences.

The controller is integrated in a Matlab/Simulink tool where appliances and renewable energy sources are modeled. In this way, the simulation is not only a framework to test the controller, but also a suitable tool to sensitize the building occupants. **Finally, the simulation and control model is validated by experimental data measured in a large size dwelling equipped with domestic appliances and renewable energy sources. Smart meters and wifi smart plugs are used to collect energy consumption data.**

In conclusion, the main novelties of this paper are summarized as follows:

- i) with respect to [1] a simulation and control model for BEMS is proposed to take into account the comfort and the priority of the building occupants. Moreover, the controller is modeled by a PN that can be easily converted into a commonly used language for PLCs;
- ii) unlike paper [6], this paper models the load dynamics considering not only the appliances maximum power and cycle time but also their warm-up period.

### **3. Simulation Framework for Appliances Modelling and Control**

This section introduces the simulation and control framework describing the BEMS behaviour. The control unit of the BEMS is specified and modeled in a PN framework and manages the appliances by respecting the user preferences. The appliances and the renewable energy sources constitute the building micro-grid and are modeled by the Matlab/Simulink tool. Moreover, the load controller is integrated in the Simulink model to perform the loads real-time control.

The Simulink model of the simulation and control systems is represented in Fig. 1 and includes 6 modules: the domestic loads for which the state of functioning (on/off) is provided, the power consumed by each load, the set-points of each load, the available energy provided by the electric main grid and the renewable sources, the total power cost and the controller modeled in a PN framework. The inputs of the controller are the power consumptions, the available power profile, the set-points and priority vectors of loads. In

particular, the available power is given by the energy bought by the main grid and the energy provided by the renewable sources. The control procedure imposes that the aggregated power consumption does not exceed the available power profile in order to avoid power curtailment, by managing the loads consumption reduction according to the comfort preferences. More in detail, according to the Italian Distribution System Operator (DSO) rules, if the available energy profile is not sufficient to satisfy the total energy demand by the domestic loads, then a power curtailment is applied to the user. To avoid this inconvenience, the load controller implements a real-time control procedure with the objective of switching off the controllable loads or reducing their consumption, according to their priorities and respecting the comfort settings.

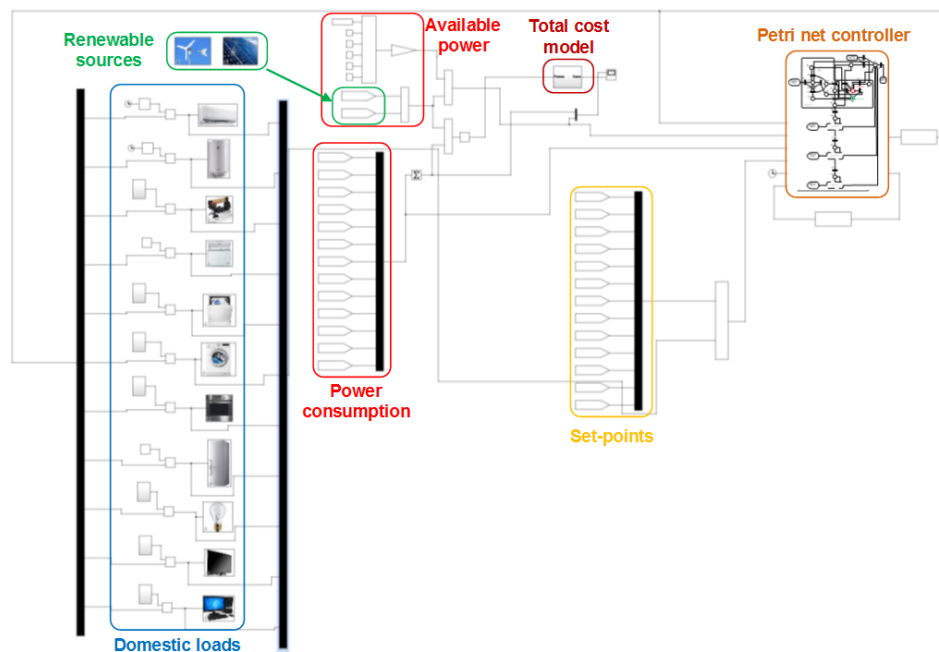

Figure 1: The Simulink model of the simulation and control framework.

#### 4. Domestic Loads Models

In this section, the most common appliances of a domestic environment are modeled and controlled by using Matlab/Simulink and Simscape tools.

It is remarked that other appliances can be modeled and included into the simulation model depending on the user necessities. Typically, the appliances can be divided in two categories: controllable and non-controllable. The controllable appliances can be switched off or partialized by a controller. In particular, the following controllable loads are modeled: HVAC system (heating and cooling mode), water heater, dishwasher, washing machine and dimmable lamps.

The non-controllable appliances are passive loads that cannot be switched off or partialized: oven, tv, pc, iron, refrigerator and freezer.

Moreover, wind and solar renewable sources are modeled and integrated in the system.

#### 4.1. HVAC System Model

The HVAC system is modeled both in heating and cooling functioning mode. Typically, these devices are composed by an external and an internal units connected by pipelines in which a refrigerant flows. They can be on/off or inverter driven. The on/off type is typically controlled by a thermostat that switches on (off) the voltage source of the compressor, keeping the air temperature at the desired level. On the other hand, in the second type, the compressor is powered by an inverter proportionally to the difference between the measured and the desired (set-point) temperatures. In this section, the second type of HVAC system is analyzed because it ensures better results for energy consumption minimization.

The model of the HVAC system is represented in Fig. 2. The main components of this model are respectively specified in Fig. 3, 4 and 5: 1) heating model, 2) cooling model, 3) building thermodynamic model and 4) cost of energy model.

In particular, the simplified heating and cooling model is shown in Fig. 3, where the inverter works with a variable power, the thermal power  $P_t$  is proportional to  $\Delta T$  that represents the difference between the desired (set-point) and measured indoor temperatures. Moreover, a saturation block imposes that the technical maximum value of  $P_t$  is as follows:

$$P_t(t) = \begin{cases} K\Delta T, & \text{if } 0 < K\Delta T < P_{t,max} \\ 0, & \text{otherwise,} \end{cases} \quad (1)$$

with  $K[m^2 * \frac{W}{m^2 * ^\circ C}]$  proportional gain that includes the heat transfer coefficient and the surface area. The electric power  $P_e(t)$  is obtained as follows:

$$P_e(t) = \frac{P_t(t)}{\gamma}, \quad (2)$$

where it holds  $\gamma = COP$  for the heating, i.e., the Coefficient of Performance, and  $\gamma = -EER$  for the cooling, i.e., the Energy Efficiency Ratio [26].

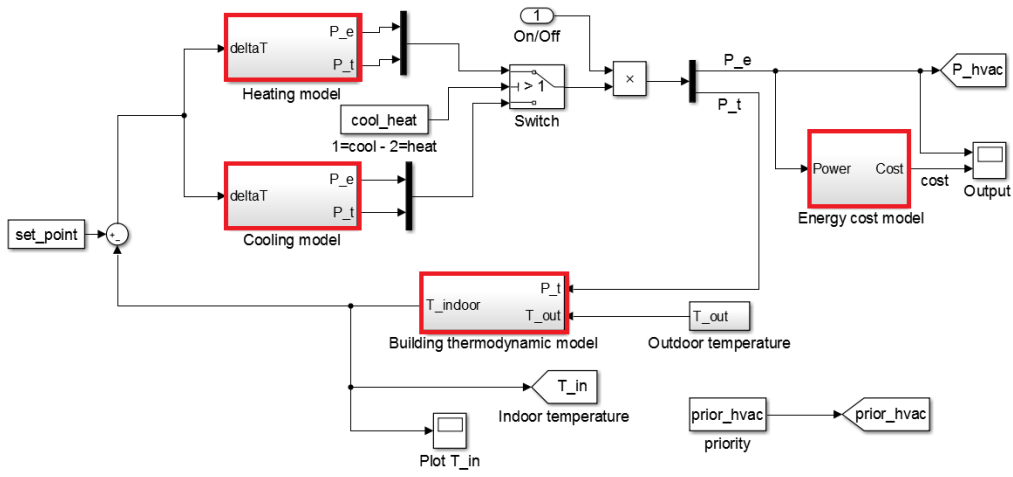

Figure 2: The Simulink model of HVAC system.

Now, in order to model the building thermodynamic the following parameters and variables are introduced:  $T_{in}(t)[^{\circ}C]$ , indoor air temperature (at time  $t$ );  $T_{out}(t)[^{\circ}C]$ , outdoor air temperature at time  $t$ ;  $R_{th}[\frac{m^2 \cdot ^{\circ}C}{W}]$ , thermal resistance;  $M[Kg]$ , air weight;  $c[\frac{J}{Kg \cdot K}]$ , specific heat at constant pressure of air;  $P_t(t)[W]$  thermal power by the HVAC system at time  $t$ ;  $P_{loss}(t)[W]$ , thermal power loss at time  $t$ .

The building thermodynamic model is shown in Fig. 4 and is described by the following equations [27]:

$$P_{loss}(t) = \frac{T_{in}(t) - T_{out}(t)}{R_{th}}, \quad (3)$$

$$\frac{dT_{in}(t)}{dt} = \frac{1}{M * c} (P_t(t) - P_{loss}(t)). \quad (4)$$

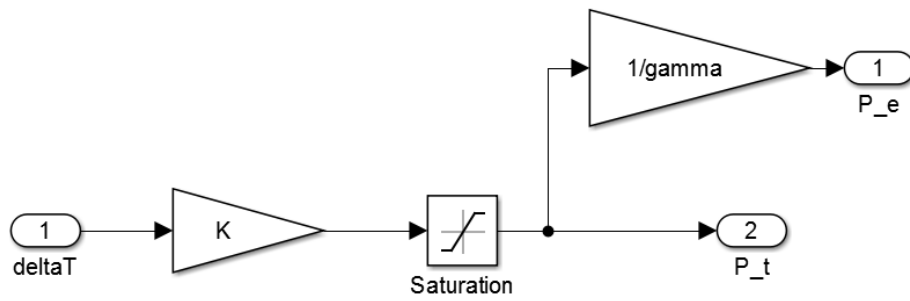

Figure 3: The Simulink model of heating and cooling systems

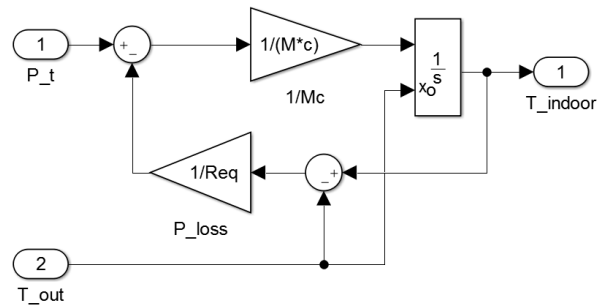

Figure 4: The Simulink model of the building thermodynamic.

Moreover, the energy cost model is shown in Fig. 5. The parameter  $T_h$  is introduced to impose the time horizon in which the energy cost is determined. Inside time horizon  $T_h$ , the cost of energy is higher during the time interval  $[T_{start}, T_{end}]$ .

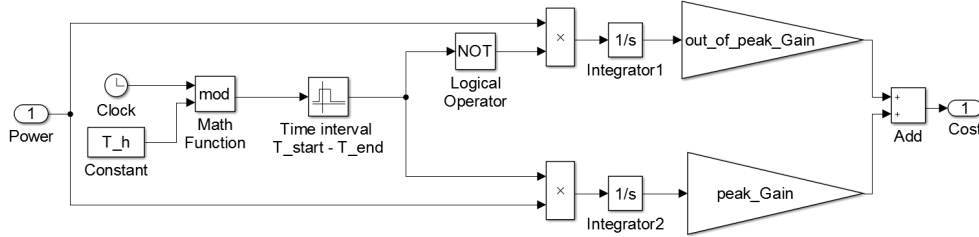

Figure 5: The Simulink model of the energy cost.

Furthermore, the outdoor temperature is modeled by using a sine curve with mean value equal to the mean air temperature of a typical day (winter day for heating, summer day for cooling).

#### 4.2. Water Heater Model

The water heater is typically composed by an electric resistance that heats up the water. The water temperature set-point can be manually set up and a thermostat allows controlling on/off the power source to keep the desired temperature. The necessary variable of the model are listed as follows:  $C[J/^\circ C]$ , thermal capacity of water in the tank;  $T_{hw}(t)[^\circ C]$ , hot water temperature in tank;  $T_{in}(t)[^\circ C]$ , indoor air temperature outside tank;  $T_{cw}[^\circ C]$ , inlet cold water temperature;  $W_d(t)[l/sec]$ , average hot water draw per time;  $\rho[kg/J]$ , density of water;  $V_l[l]$ , volume of tank;  $C_p[J/kg * ^\circ C]$ , specific heat of the water;  $SA[m^2]$ , surface area of the tank;  $R_{th}[\frac{m^2 * ^\circ C}{W}]$ , thermal resistance of the tank.

The heat dynamics is modeled by the following differential equation [28]:

$$C \frac{dT_{hw}(t)}{dt} = G(T_{in} - T_{hw}(t)) + HW_d(t)(T_{cw} - T_{hw}(t)) + P_t(t), \quad (5)$$

with  $C = \rho C_p V_l$ ,  $G = \frac{SA}{R_{th}}$  and  $H = \rho C_p$ . Moreover, the term  $G(T_{in} - T_{hw}(t))$  represents the heat lost in the tank and  $HW_d(t)(T_{cw} - T_{hw}(t))$  is the heat lost to handle hot water. The Simulink model of the electric water heater is reported in Fig. 6. The water flow is denoted by a variable signal in the considered time interval, while the thermostat is modeled by a relay block that drives the on/off switch of the system. The thermostat is controlled by the temperature difference  $\Delta T = T_{hw,set} - T_{hw}(t)$ .

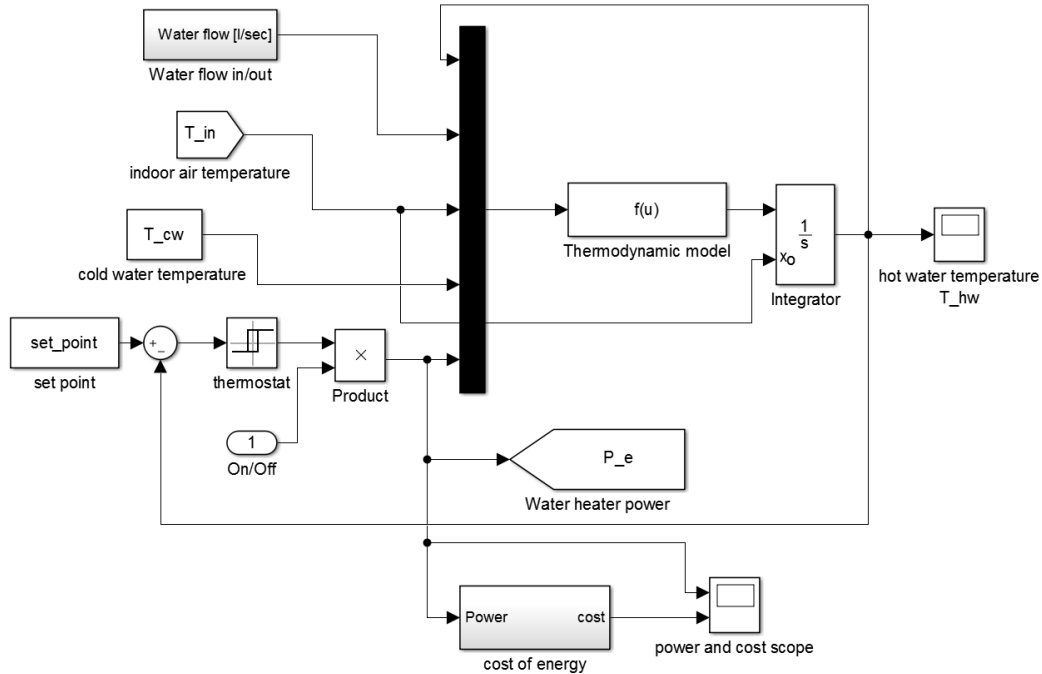

Figure 6: The Simulink model of the electric water heater.

#### 4.3. Washing Machine and Dishwasher Models

Washing machines and dishwashers are heterogeneous systems composed by mechanical parts, a hydraulic system, a thermal system and an electronic control system. To model such appliances, an asynchronous monophasic motor is considered [29] in order to allow the rotation of the machine. In addition, a thermal system heats up the water according to the washing

program selected by the user. The parameters of the asynchronous motor are reported in Table 1 and the direct and inverse impedances of the motor are formalized in equations (6) and (7), respectively:

$$z_{forward} = (j\frac{X_m}{2}) || (\frac{R_2}{2s} - j\frac{X_2}{2}), \quad (6)$$

$$z_{backward} = (j\frac{X_m}{2}) || (\frac{R_2}{2(2-s)} - j\frac{X_2}{2}). \quad (7)$$

Then, the input impedance is the following:

$$z_i = z_1 + z_{forward} + z_{backward}, \quad (8)$$

where  $z_1$  is the stator impedance.

Table 1: Asynchronous motor parameters

Asynchronous Motor
Washing machine / Dishwasher
Source Voltage: $V$
Source Frequency: $f$
Stator Resistance: $R_1$
Stator Reactance: $X_1$
Rotor Resistance: $R_2$
Rotor Reactance: $X_2$
Magnetic Reactance: $X_m$
Slide coefficient: $s$
Number of poles: $p$

The output power is given by (9) where  $I_1 = \frac{V}{z_i}$  is the stator current:

$$P = VI_1 \cos\phi. \quad (9)$$

The stator losses, the output mechanical power and the rotation per minute (rpm) are respectively computed as follows:

$$P_{loss,st} = |I_1|^2 R_1, \quad (10)$$

$$P_m = |I_1|^2 (R_{forward} - R_{backward})(1 - s), \quad (11)$$

$$rpm = \frac{Vf}{p}. \quad (12)$$

The water heaters of washing machines and dishwashers to manage high temperatures are modeled as in section 4.2. Moreover, different machine programs can be considered and modeled by adopting lookup tables.

#### 4.4. Dimmable Lamp Model

The dimmable lamp is controlled by a dimmer that is an electronic regulator able to control the power absorbed by the lamp and to vary its lighting intensity. It is modeled by adopting the Simscape tool [30] that enables to rapidly create physical systems, such as electric devices, by assembling fundamental components into a schematic, within the Simulink environment (see Fig. 7). In this case, the Simscape physical blocks are a DC voltage source, a resistor, a voltage sensor and a current sensor. The output of the Simscape blocks are input of Simulink blocks through the PS-Simulink converter blocks that convert physical signals into Simulink signals (see Fig. 7).

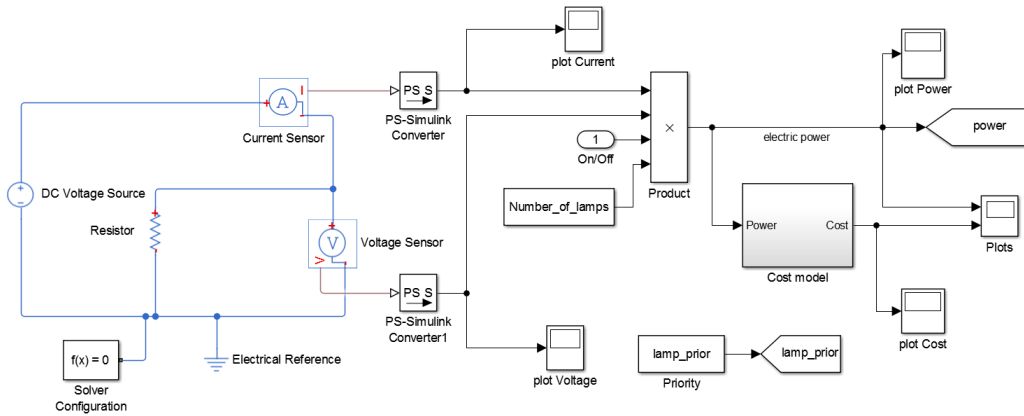

Figure 7: The Simulink model of the dimmable lamps.

In addition, the user can set the number of lamps to be used and the source voltage in the range  $V_{min} - V_{max}$ .

#### 4.5. Non-Controllable Loads

Concerning the non-controllable loads, the oven, the iron, the refrigerator and the freezer are modelled by the following equation [27]:

$$C \frac{dT(t)}{dt} = G(T_{in} - T(t)) + Q(t) \quad (13)$$

where  $Q(t) = P(t)$  for oven and iron,  $Q(t) = P(t)EER$  for refrigerator and freezer.

It is evident that  $C$ ,  $G$ ,  $T_{in}$ ,  $T(t)$  and  $Q(t)$  are different for each appliance according to their characteristics.

The Simulink model that describes TV and PC is depicted in Fig. 8. The power consumption is assumed to be constant when the two appliances are on.

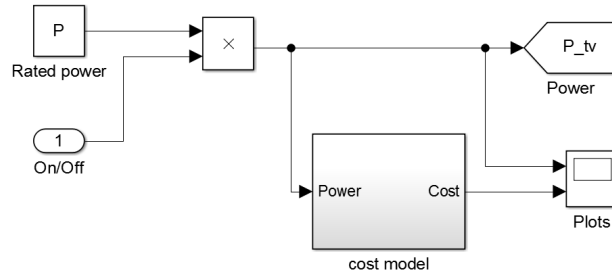

Figure 8: The Simulink model of TV and PC.

#### 4.6. Renewable Energies

Finally, wind and photovoltaic renewable energy sources are modeled by considering their production forecasts for a time period of 24 hours. The forecasted power  $P_f(t)$  and time data vectors are saved in a lookup table in the Simulink model both for eolic and photovoltaic (see Fig. 9).

### 5. Controller Model in a Petri Net Framework

This section, deals with the problem of controlling the building energy consumption by designing the load controller in a PN framework. First, some basic definitions on PN [4] are recalled, then, the load controller is described in detail.

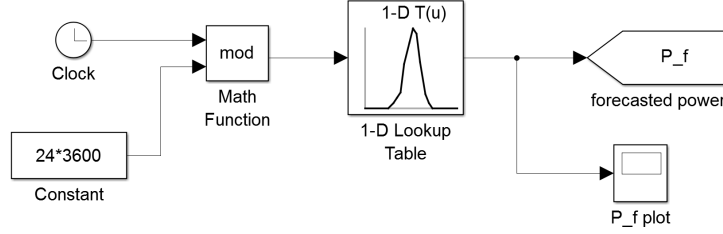

Figure 9: The Simulink model of wind and photovoltaic sources.

### 5.1. Basic Definitions

A PN is a bipartite graph described by the four-tuple  $PN=(P, T, Pre, Post)$ , where  $P$  is a set of places with  $|P| = m$  and  $T$  is a set of transitions with  $|T| = n$ . Note that symbol  $|A|$  denotes the cardinality of the generic set  $A$ . Matrices  $Pre : P \times T \rightarrow \mathbb{N}^{m \times n}$  and  $Post : P \times T \rightarrow \mathbb{N}^{m \times n}$  are the *pre-* and *post-*incidence matrices, respectively, which specify the arcs connecting places and transitions. More precisely, for each  $p \in P$  and  $t \in T$  element  $Pre(p, t)$  ( $Post(p, t)$ ) is equal to a natural number indicating the arc multiplicity if an arc going from  $p$  to  $t$  (from  $t$  to  $p$ ) exists, and it equals 0 otherwise. Note that  $\mathbb{N}$  is the set of non-negative integers. Matrix  $C = Post - Pre$  is the  $m \times n$  incidence matrix of the net  $PN$ .

For the pre- and post-sets the dot notation is used, e.g.,  $\bullet t = \{p \in P : Pre(p, t) > 0\}$ . The state of a PN is given by its current marking, which is a mapping  $M : P \rightarrow \mathbb{N}^m$ , assigning to each place of the net a nonnegative number of tokens. A PN system  $\langle PN, M_0 \rangle$  is a net  $PN$  with an initial marking  $M_0$ . A transition  $t_j \in T$  is enabled at a marking  $M$  if and only if for each  $p \in \bullet t_j$  it holds:  $M(p) \geq Pre(p, t_j)$ . When  $t_j$  fires, the PN reaches a new marking  $M'$ , that is  $M' = M + C \cdot \vec{t}_j$ , where  $\vec{t}_j$  is the  $n$ -dimensional firing vector corresponding to the  $j$ -th canonical basis vector.

### 5.2. Controller Petri Net Model

The controller is modeled by a set of PN modules: each module is devoted to control a particular load. Furthermore, the modules are sequentially connected starting from the lowest priority level (load 1) and ending to the highest priority level (load  $n$ ) as shown in Fig. 10. For the sake of simplicity, Fig. 10 shows just the PN control module of load 1, since the other PN modules are the same. Moreover, Tables 2 and 3 describe the meaning of the PN places and transitions, respectively.

At the initial marking  $M_0$  shown in Fig. 10, the controller is inactive (place  $p_1$  is unmarked), the specific load is on (place  $p_6$  marked) and the set-point is not matched (place  $p_{10}$  marked). The set-point matched or set-point not matched are defined for determining if the comfort settings of the considered load are respected or not.

Now, assume that a demand reduction is necessary because the building consumption exceeds the available energy profile. More precisely, when the smart meter detects the overconsumption issue, the BEMS starts a procedure to reduce the loads consumption (transition  $t_0$  fires). The BEMS performs the control procedure ( $t_1$  fires and place  $p_2$  is marked) starting from the load with lowest priority (load 1). Since load 1 is on (place  $p_6$  marked), the BEMS checks if the load set-point is matched (transition  $t_2$  fires and places  $p_{12}$  and  $p_3$  are marked). For each generic load two possible cases occur: a) the set-point of load 1 is matched (transition  $t_{11}$  fires and place  $p_9$  is marked); b) the set-point of load 1 is not matched (place  $p_{10}$  is marked).

(a): *The set-point is matched*

Since the load set point is matched (place  $p_9$  is marked), the BEMS turns off load 1 in order to reduce the building consumptions without penalizing the user comfort:  $t_8$  fires and place  $p_8$  is marked enabling  $t_5$ ; in turn  $t_5$  fires and place  $p_5$  is marked. At this point, transition  $t_6$  fires and place  $p_1$  is marked again. The BEMS verifies the consumption reduction. If the obtained consumption reduction is sufficient to avoid power curtailment, then the control procedure terminates (transition  $t_{13}$  fires). On the contrary, if the consumption reduction is not sufficient, the BEMS restarts the control procedure ( $t_1$  fires). Now, load 1 is off, and the BEMS has to verify the possibility to turn off the next load (transition  $t_4$  fires and place  $p_4$  is marked). Moreover, when a load is off, the set-point can turn into the state of not matched (transition  $t_9$  fires and place  $p_{13}$  is marked enabling transition  $t_7$ ): the BEMS switches on the load (transition  $t_7$  fires).

(b): *The set-point is not matched*

Since the load set-point is not matched (place  $p_{10}$  is marked), the BEMS cannot switch off load 1 (transition  $t_{10}$  fires and place  $p_{11}$  is marked enabling the transition  $t_3$ ) and verifies the possibility to turn off the next load (transition  $t_3$  fires and place  $p_4$  is marked).

Let us remark that for the dimmable lamps when place  $p_5$  is marked, it means

that the load is not off but the load energy consumption is set to a minimum value necessary to guarantee 300 lux of illuminance in the room [31].

Table 2: Place description.

<i>Place</i>	Description
$p_1$	The BEMS starts the control procedure
$p_2$	The BEMS checks the status of the selected load
$p_3$	The load is on
$p_4$	The control procedure ends for the selected load and is ready to start for the next load
$p_5$	The load is switched off (the load energy consumption is off or reduced)
$p_6$	The load is switched on
$p_7$	Conditions for re-initializing the BEMS control procedure (place $p_1$ )
$p_8$	Conditions for switch off the load because the set-point is matched
$p_9$	The load set-point is matched
$p_{10}$	The load set-point is not matched
$p_{11}$	Conditions for start the control procedure of the next load because the set-point is not matched.
$p_{12}$	Set-point control
$p_{13}$	Conditions for switch on the load
$p_{14}$	The BEMS starts the control procedure for the next load.

## 6. Case Study

In this section, in order to show the effectiveness of the proposed model, a real apartment situated in Bari, a city of southern Italy, is studied, that is equipped with a  $3kW$  photovoltaic plant and includes all the considered appliances. Furthermore, for the validation of the simulation and control system, the dwelling has been equipped with a wifi control system composed

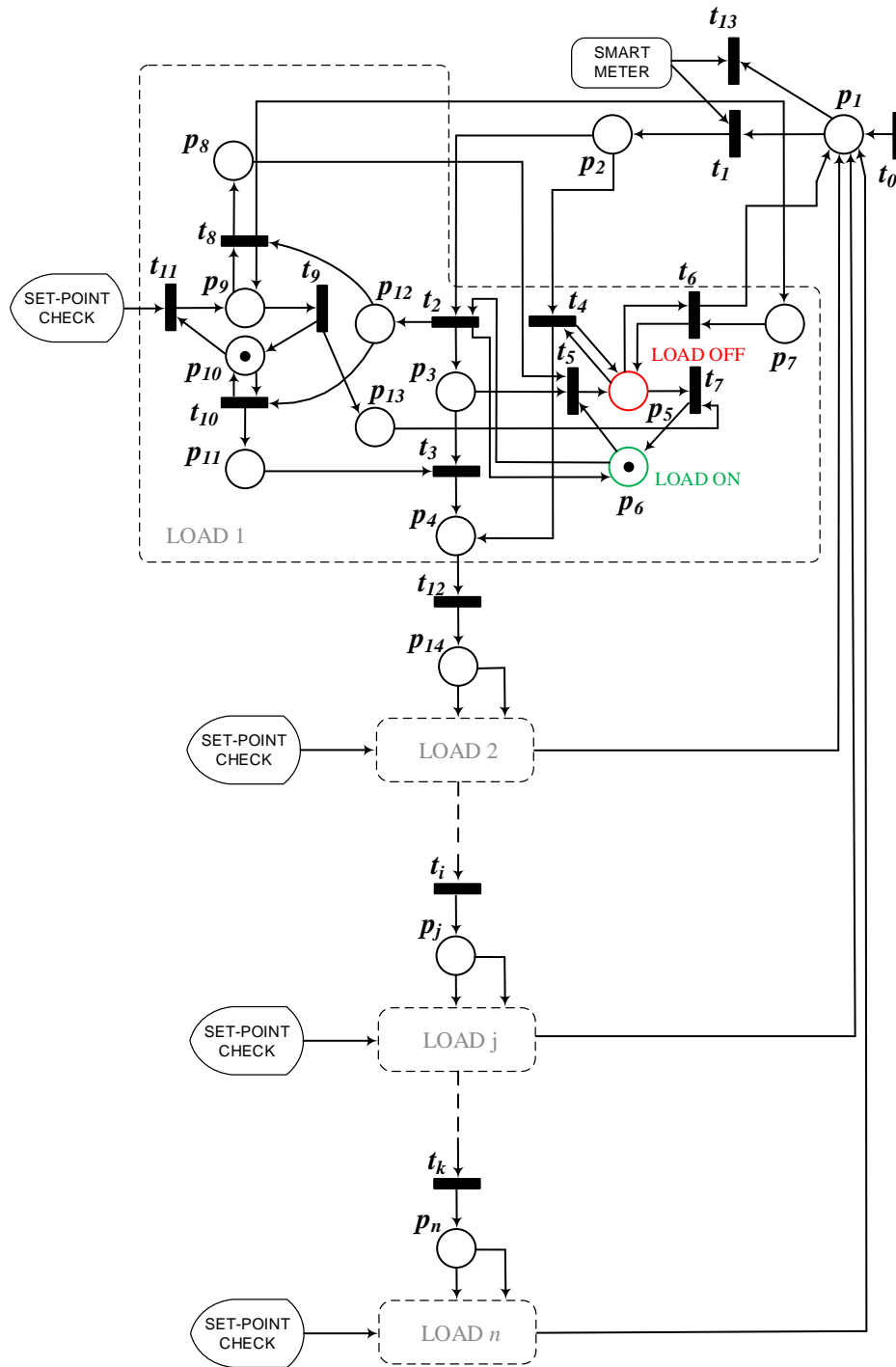

Figure 10: The load controller model.

Table 3: Transition description.

<i>Transition</i>	Description
$t_0$	The control procedure starts
$t_1$	The BEMS starts to investigate the status of the load
$t_2$	Verify of the set-point status
$t_3$	End of the control procedure for the selected load
$t_4$	End of the control procedure for the selected load
$t_5$	Switch the load off
$t_6$	Re-initialization of the BEMS control procedure
$t_7$	Switch the load on
$t_8$	Verify of the condition set-point matched
$t_9$	Turn set-point in the state of not matched
$t_{10}$	Verify of the condition set-point not matched
$t_{11}$	Match of the set-point
$t_{12}$	Start of the control procedure of the next load
$t_{13}$	End of the control procedure

by: 1) a smart meter that measures the aggregated current and voltage data of the considered appliances; 2) smart plugs that controls the household electric appliances and are able to i) activate/deactivate the appliance, ii) measure appliance consumption with an accuracy of 0.2%, iii) communicate and transmit data to the central controller; 3) a PLC devoted to apply the control strategy by managing the measurement and control devices. To this aim the PN control strategy, has been converted to a ladder diagram program, downloaded in the PLC.

In particular, the consumption of the domestic appliances during a typical winter day is studied. It is remarked that applying the model to a summer day scenario will provide very similar results because the HVAC is the only appliance that will be used in a different functioning mode (cooling mode). For these reasons no significant differences will be obtained in term of aggregated consumption and cost if compared to a winter day scenario. In this case study, the simulations are performed and compared in two cases: i) all the appliances are not controlled; ii) the HVAC system, the water heater, the dishwasher, the washing machine, the dimmable lamps are controlled by the proposed control logic. In the following the parameters of the considered domestic loads are described in details.

- 1) The dishwasher has a rated power of  $1950W$  and the water heater is described by the following parameters:  $V_l = 3$ ;  $SA = 0.3$ ;  $R_{th} = 1$ ;  $\rho = 1$ ;  $C_p = 4186$ ;  $T_{in} = 10^\circ C$ . Moreover, the parameters settings of the asynchronous motors are reported in Table 4. The functioning of the dishwasher is characterized by four different washing programs: eco, light, classic and intense. Here, the functioning of the cheap eco program is described and simulated in order to allow energy saving by working at low temperature ( $50^\circ C$ ). The eco program works for 130 minutes: the electric motor is activated after 3 minutes and it stays on for 117 minutes with the last 10 minutes dedicated to the cold air flow to eliminate humidity; the water heater is activated after 30 seconds and stays on for 85 minutes allowing the water temperature to rise up to  $50^\circ C$ . The Simulink model of the dishwasher with the four selectable programs is shown in Fig. 11.
  
- 2) The washing machine has a rated power of  $1950W$  and the parameters of the water heater are chosen according to the functioning program:  $V_l = 5$ ;  $SA = 0.3$ ;  $R_{th} = 1$ ;  $\rho = 1$ ;  $C_p = 4186$ ;  $T_{in} = 10^\circ C$ . The thermostat range of tolerance is  $\pm 0.05$  and the parameters of the asynchronous motors are reported in Table 4. The considered washing programs are white cotton, eco cotton, synthetics, delicates, woolens and centrifuge. In this case, the behaviour of the white cotton program that lasts 180 minutes is simulated. The washing machine works as follows: the motor starts to work after 3 minutes allowing the basket to charge water, and stays on for 162 minutes moving the basket at 550 rpm and working at half power. Then the centrifuge is activated for 15 minutes at 1100rpm and at maximum power. The water heater of the machine is on after one second to rise up to the temperature of  $90^\circ C$  (after 14 minutes), then it keeps on working for 150 minutes. The total power consumed by the white cotton program is given by the sum of the motor and water heater consumptions and it is about  $2270W$  at peak periods. The Simulink model of the washing machine is shown in Fig. 12. The asynchronous motor parameters for the washing machine and the dishwasher are specified in Table 4.
  
- 3) The HVAC system works in heating mode according to the following parameters: rated power  $8000W$ ,  $COP = 3.2$ ,  $T_{out,mean} = 10^\circ C$  and  $T_{in,set} = 22^\circ C$ .

- 4) The Simscape library is used to model a dimmable lamp of  $220V$  and  $15W$  and the source voltage can vary in the range  $[0 - 220]V$ , as it is shown in Fig. 14.
- 5) The water heater is characterized by the following parameters:  $V_l = 50$ ;  $SA = 1.2$ ;  $R_{th} = 1$ , rated electric power  $1500W$ , range of tolerance for thermostat  $\pm 2$ ,  $T_{hw,set} = 50^\circ C$  and  $T_{cw} = 15^\circ C$ .

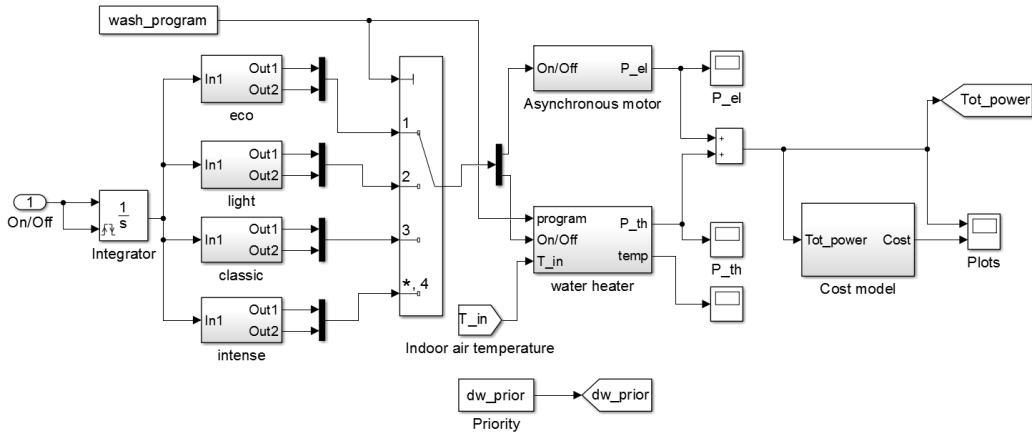

Figure 11: The Simulink model of the dishwasher.

The parameters of oven, iron, refrigerator and freezer are reported in Table 5. In addition, the TV and PC have respectively a power consumption of  $120W$  and  $100W$ .

The on intervals of the appliances and the priorities of the controllable appliances are reported in Table 6.

Moreover, a GUI is designed to set up all the parameters of the system. Fig. 13 shows a screen-shot of the simulator panel that is devoted to start and stop the simulation and to set up and plot the appliances parameters. In particular, the power grid box allows to set up the power source by the grid. In particular, according to the Italian DSO tariff [32], three power levels can be selected that correspond to  $3.3$ ,  $4.5$  or  $6kW$ . In addition, Fig. 14 provides the layout of the GUI blocks of the controllable loads and of the wind energy.

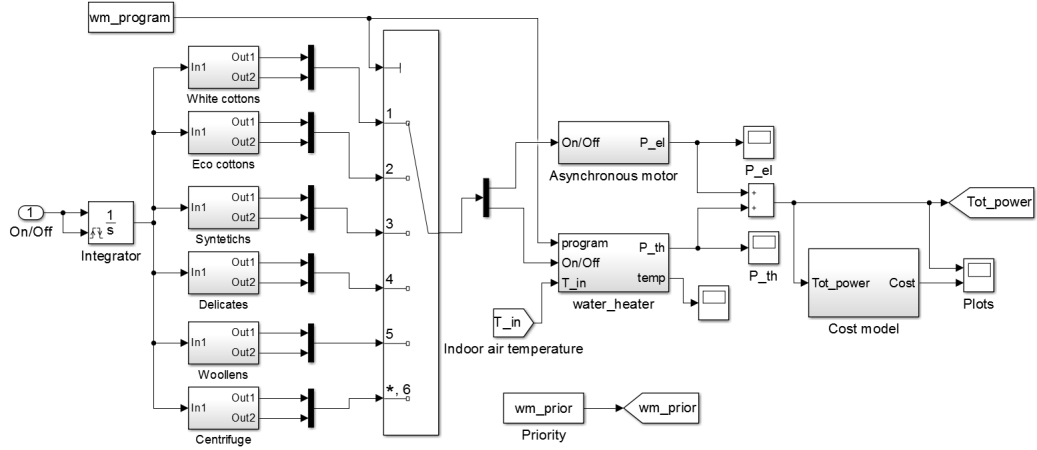

Figure 12: The Simulink model of the washing machine.

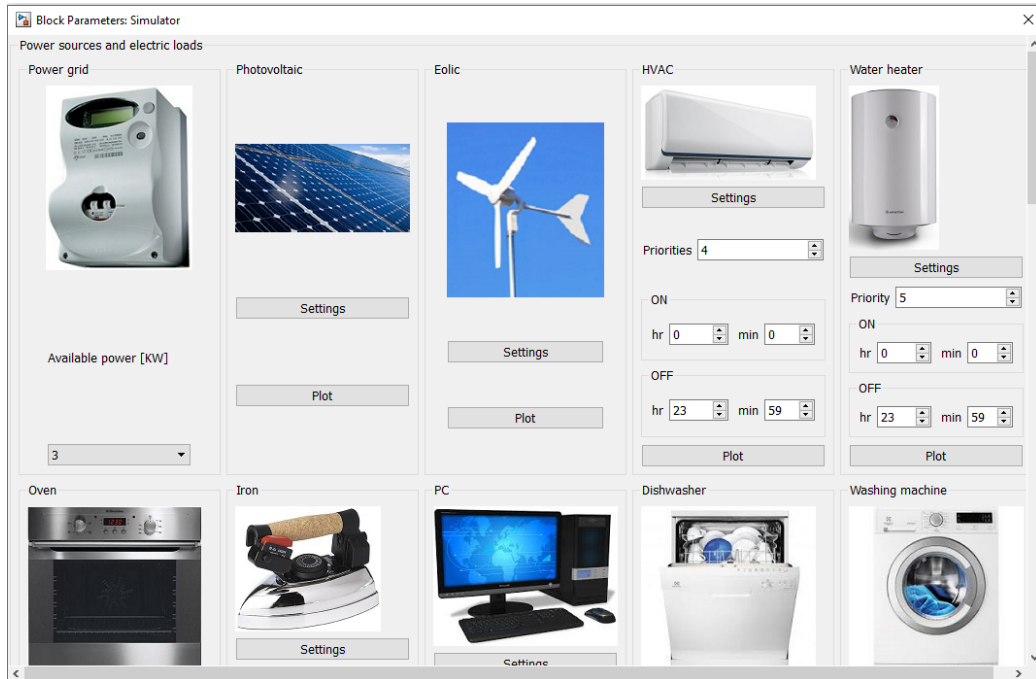

Figure 13: A screenshot of the GUI of the simulator panel.

Table 4: Asynchronous motor parameters

Asynchronous Motor		
	Washing machine	Dishwasher
$V$	220V	220V
$f$	50Hz	50Hz
$R_1$	4.2 $\Omega$	0.3 $\Omega$
$X_1$	1.03 $\Omega$	0.92 $\Omega$
$R_2$	10.05 $\Omega$	4.82 $\Omega$
$X_2$	2.97 $\Omega$	5.14 $\Omega$
$X_m$	58.17 $\Omega$	58.18 $\Omega$
$s$	0.05	0.05
$p$	10	4

Table 5: The non-controllable loads parameters

	Oven	Iron	Refrigerator	Freezer
Rated power [W]	2000	1300	120	120
$T_{set}$ [ $^{\circ}C$ ]	180	140	5	-18
Thermostat range [ $^{\circ}C$ ]	$\pm 10$	$\pm 10$	$\pm 1$	$\pm 1$
$C$	60	1031.63	35000	30000
$G$	0.23	3.26	1.16	1.16
$EER$	/	/	3.5	2.3

To set up the simulations, 3.3kW of available power from the main grid are considered. In addition, two different production profiles are initialized for the wind and photovoltaic energy. Therefore, to avoid power curtailment by the DSO, the aggregated load of the dwelling must not exceed the total available profile (sum of power from the grid and power from the renewable sources) for a specific time horizon. In this case, if the power consumption by the aggregated load exceeds the available power for more than 2 minutes, a power curtailment will occur by the DSO [32].

Table 6: Domestic Loads settings for a winter day

Domestic loads	On/off intervals	Priority
Dishwasher	on: 15.30; 21.30 ( $pd_1$ )	1
Washing machine	on: 19.00 ( $pr_1$ )	2
HVAC	on: 19.00-23.00 (heating mode)	3
Lights	on: 6.30-7.00; 17.00-18.00; 20.30-23.59	4
Water heater	on: h24	5
Oven	on: 12.00-13.00; 20.30-21.00	/
Iron	on: 15.00-16.00	/
TV	on: 8.00-8.30; 11.00-11.50; 13.00-15.00; 20.00-23.59.	/
PC	on: 8.30-13.00; 14.30-16.30; 19.30-21.30	/
Refrigerator	on: h24	/
Freezer	on: h24	/

Two simulations are performed to show the PN control efficacy on the loads consumption: case i) simulation of the aggregated consumption without PN control; case ii) simulation of the aggregated consumption by enabling the control. Fig. 15 shows the results of case i): the total load demand exceeds the available power profile in different time periods for more than two minutes, rising up to about  $8kW$ . This situation leads to the DSO power curtailment: to respect the DSO rules and consequently to avoid power curtailment, the load controller is activated. The result of the case ii) simulation is depicted in Fig. 16. By comparing Fig. 15 and Fig. 16, it is evident how the application of the controller allows a total consumption reduction in the time periods where the aggregated load exceeds the available power. This result ensures the continuity of the power sourcing and consequently avoids that all appliances are shut down. Moreover, Fig. 17 depicts the incremental curves of cost in case i and case ii.

In addition, Fig. 18 shows in detail the effect of the controller application on the controllable loads: the power consumption and cost profiles resulting by the two simulations are compared. Starting from the load with lowest

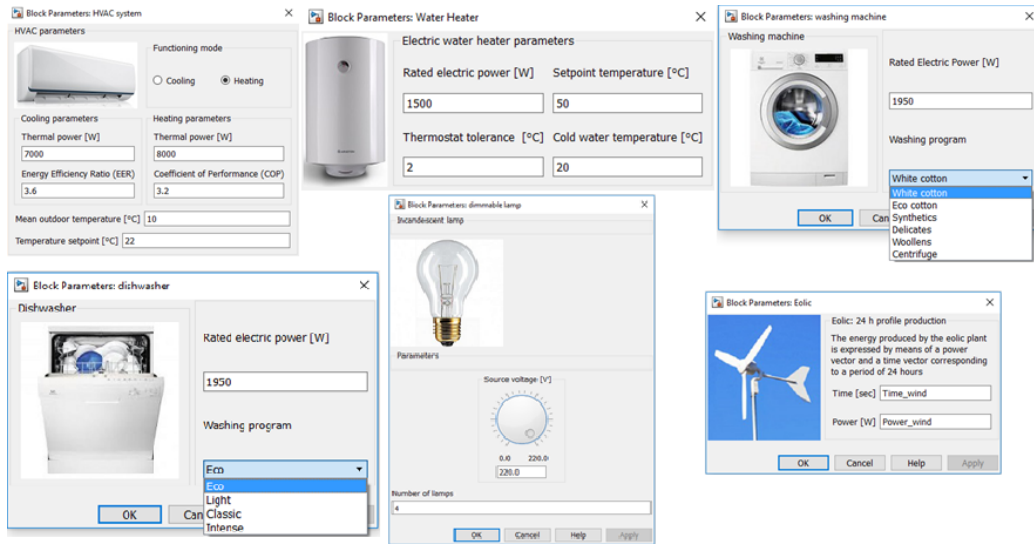

Figure 14: The layout of the GUI blocks of controllable loads and eolic.

priority, i.e., the dishwasher, and following the priority list of Table 6, the controller reduces the power consumption of each appliance in the time periods where the aggregated load overcomes the available power. The controller action allows the power supply seamless, respecting the comfort and reducing the cost of energy for each load.

### 6.1. Model validation

To validate the performance of the simulation and control system, it is necessary determining how closely the simulation model represents the real system and it is here achieved considering 30 winter days in March 2017. A scenario is associated to each day to be considered both for model simulation and real plant application. In particular, the performance index is the incremental curve of cost during a day. Indeed, the dwelling users are very interested in the economic aspect and the energy consumption is related to the cost. To validate and test the simulation and control model the performance index is evaluated on 30 days. To this purpose, Fig. 19 shows the incremental curve of the average cost obtained respectively by the 30 simulated and real scenarios. The results prove that the simulation closely represents the real system. It is remarked that the simulation model determines an energy cost equal to 3.3€ in a winter day, while the measures obtained by the smart

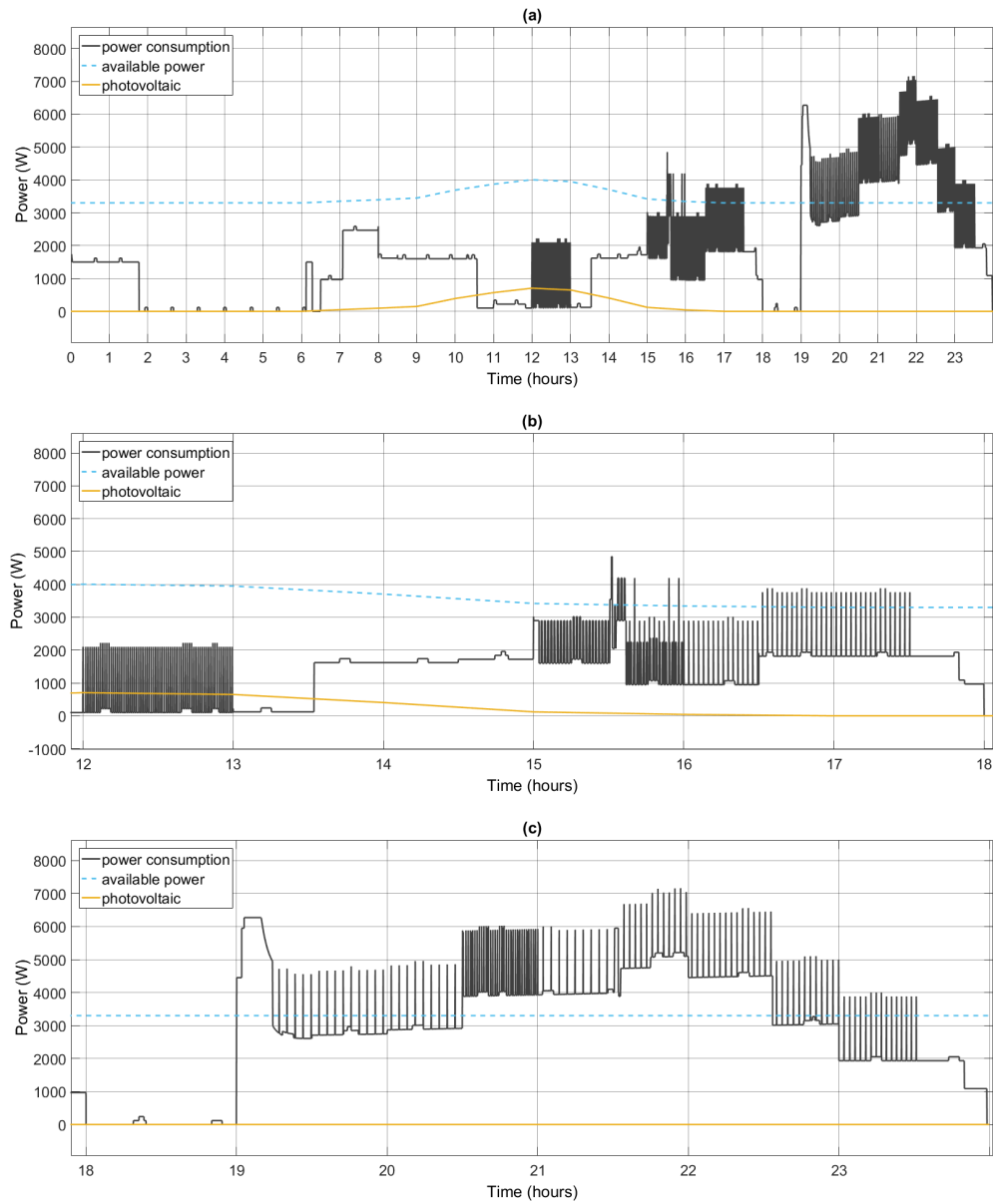

Figure 15: (a): The 24h power consumption, available power and photovoltaic power production without loads control. (b): zoom of graphic (a) from  $t = 12$  to  $t = 18$ . (c): zoom of graphic (a) from  $t = 18$  to the end of the day.

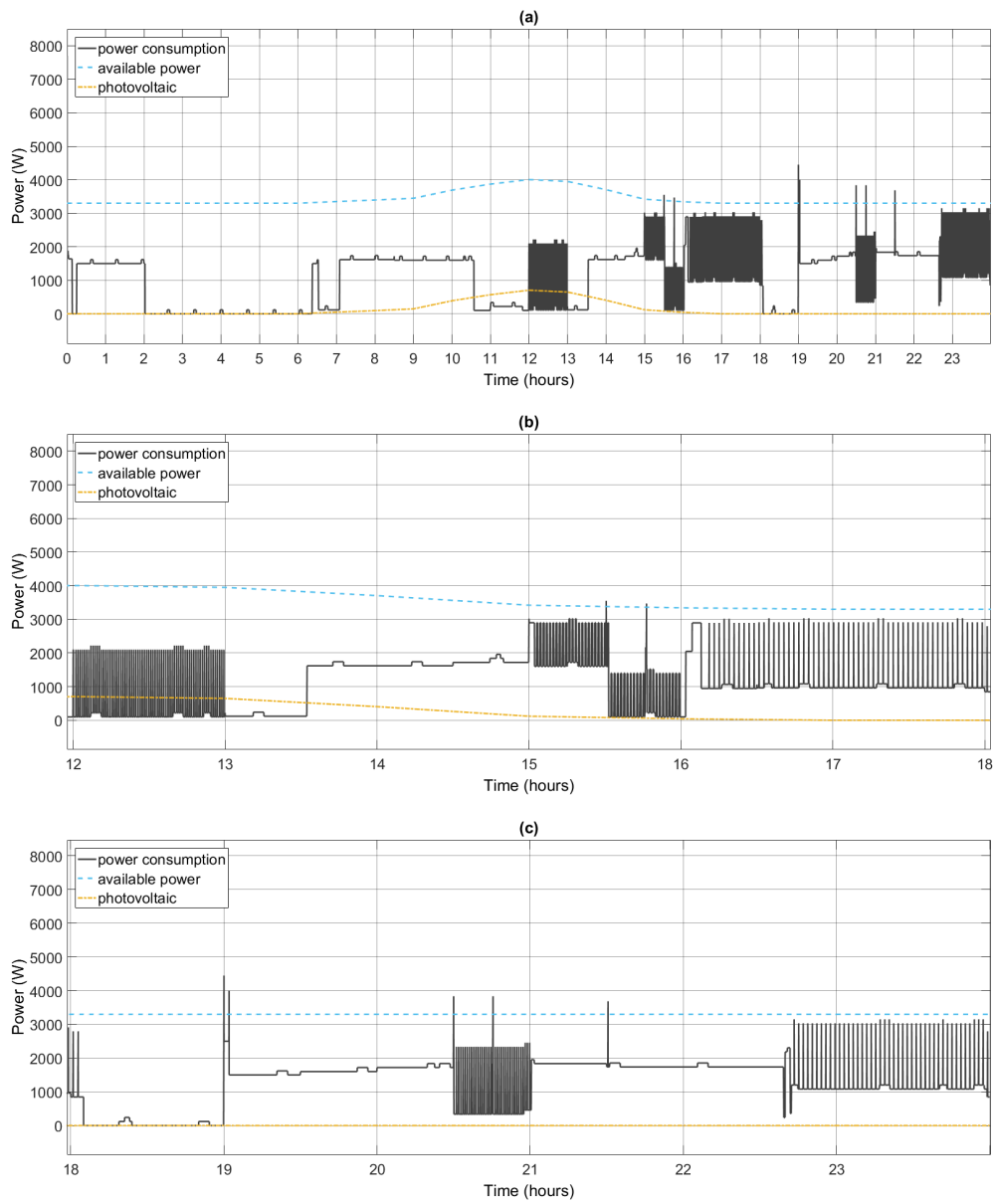

Figure 16: (a): The 24h power consumption, available power and photovoltaic power production with loads control. (b): zoom of graphic (a) from  $t = 12$  to  $t = 18$ . (c): zoom of graphic (a) from  $t = 18$  to the end of the day.

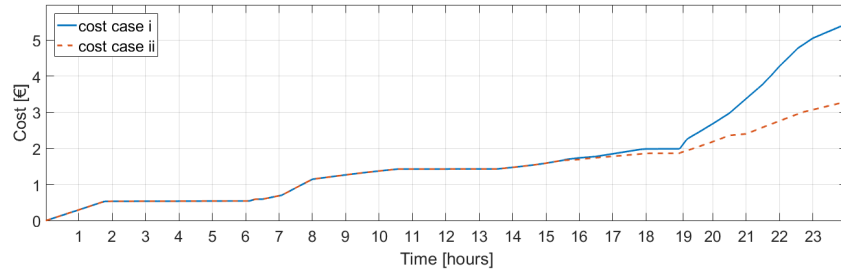
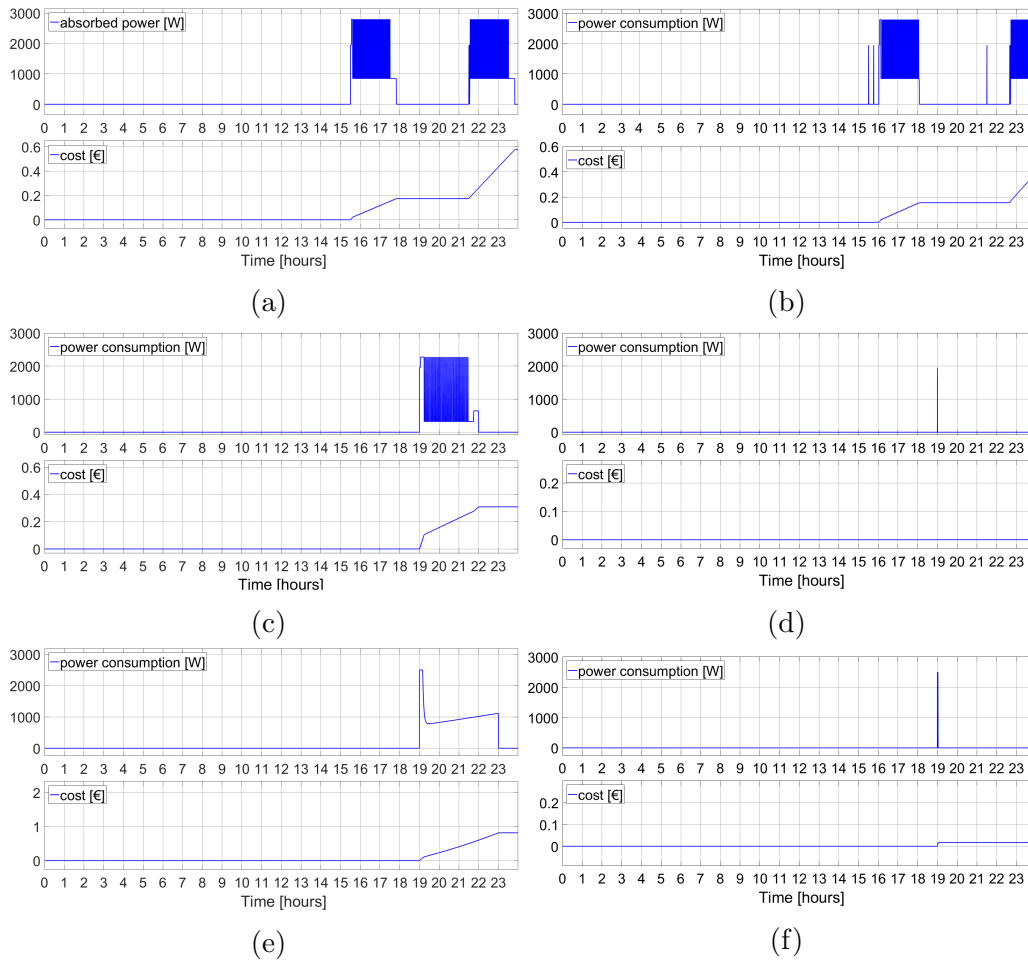

Figure 17: The cost of appliances consumption in case i and case ii.



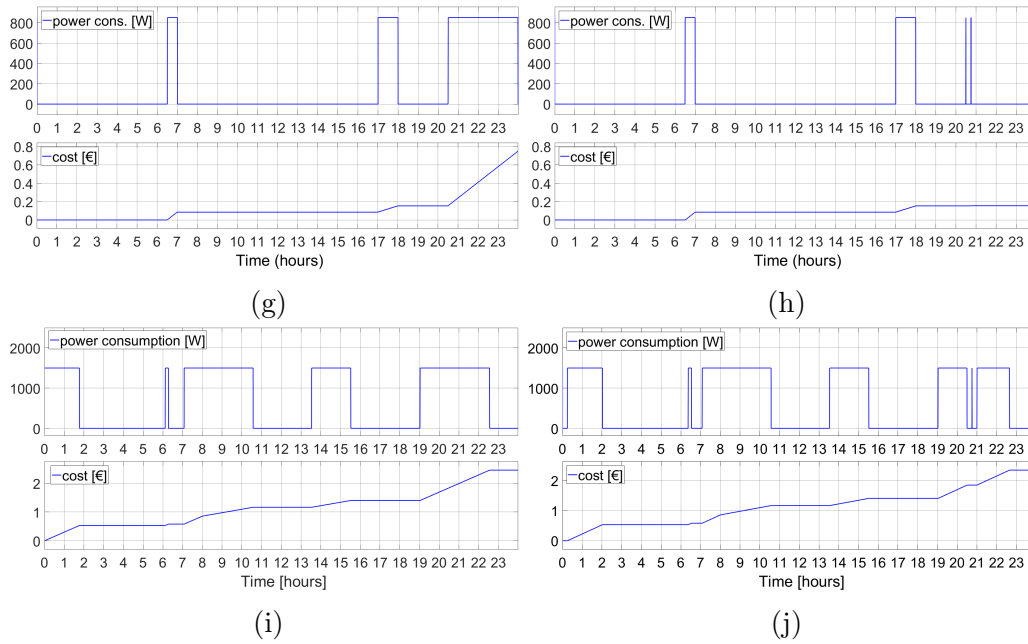

Figure 18: The power consumption and cost daily profiles with and without the PN control: (a), (c), (e), (g), (i) show consumption and cost profiles without control of dishwasher, washing machine, HVAC, lights and water heater, respectively; (b), (d), (f), (h), (j) show consumption and cost profiles under control application of dishwasher, washing machine, HVAC, lights and water heater, respectively.

meter show an average cost of 3.15€ with a consequent relative error of 4.8 %.

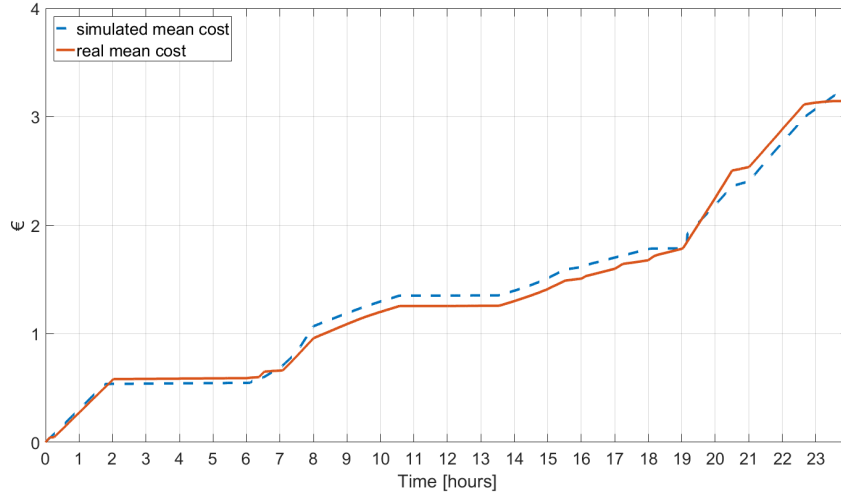

Figure 19: The comparison between the mean cost of the simulated and real scenarios during 30 days in winter.

## 7. Conclusions

This paper proposes a simulation and control model in a Matlab/Simulink environment and a Petri Net (PN) framework to manage building appliances consumption. This model allows a Building Energy Management System (BEMS) to perform energy consumption estimation and control of different kind of appliances. Indeed, the appliances models are integrated in a simulator able to provide their energy consumptions and costs. The designed simulator can help to analyze many scenarios during peak and off peak demand and allows the user to reduce the usage of some loads and their associated costs. To this aim, a PN model is proposed to describe the control of the load usage. The PN allows specifying the BEMS control strategy that guarantees the comfort conditions for each of the loads on the basis of the user preferences and to avoid power supply curtailment. The modeling and control techniques are applied to a building with 12 different loads. The simulation results validate the model and show the effectiveness of the proposed control

strategy. Future research will propose a larger simulation campaign, including other appliances, and the optimization of the control strategy. Moreover, the optimal set-points for each appliance will be investigated.

## 8. Appendix

### Nomenclature

#### *List of Acronyms*

Building Energy Management (BEM).  
 Building Energy Management System (BEMS).  
 Demand Side Management (DSM).  
 Distribution System Operator (DSO).  
 Direct Current (DC).  
 Heating Ventilation and Air Conditioning (HVAC).  
 Information and Communication Technologies (ICT).  
 Petri Net (PN).  
 Programmable Logic Controller (PLC).

#### *Parameters*

$K$ , proportional gain including the heat transfer coefficient and the surface area [ $m^2 * \frac{W}{m^2 * ^\circ C}$ ].  
 $COP$ , Coefficient of Performance for heating system.  
 $EER$ , Energy Efficiency Ratio.  
 $R_{th}$ , thermal resistance [ $\frac{m^2 * ^\circ C}{W}$ ].  
 $M$ , air weight [ $Kg$ ].  
 $c$ , air specific heat at constant pressure [ $\frac{J}{Kg * K}$ ].  
 $T_h$ , time horizon,  $T_h \in \mathbb{R}$ .  
 $T_{start}$ , start time of time horizon  $T_h$  [ $hh : mm$ ].  
 $T_{end}$ , end time of time horizon  $T_h$  [ $hh : mm$ ].  
 $T_{out,mean}$ , mean of outdoor air temperature [ $^\circ C$ ].  
 $C$ , thermal capacity of water in the tank [ $J/^\circ C$ ].  
 $\rho$ , density of water [ $Kg/J$ ].  
 $V_l$ , volume of tank [ $l$ ].  
 $C_p$ , specific heat of the water [ $J/Kg * ^\circ C$ ].  
 $SA$ , surface area of the tank [ $m^2$ ].  
 $V$ , source voltage of the asynchronous motor [ $V$ ].  
 $f$ , frequency of the asynchronous motor [ $Hz$ ].

$R_1$ , stator resistance of the asynchronous motor [ $\Omega$ ].  
 $R_2$ , rotor resistance of the asynchronous motor [ $\Omega$ ].  
 $X_1$ , stator reactance of the asynchronous motor [ $\Omega$ ].  
 $X_2$ , rotor reactance of the asynchronous motor [ $\Omega$ ].  
 $X_m$ , magnetic reactance of the asynchronous motor [ $\Omega$ ].  
 $s$ , slide coefficient of the asynchronous motor.  
 $p$ , number of poles of the asynchronous motor.  
 $z_1$ , stator impedance of the asynchronous motor [ $\Omega$ ].  
 $z_{forward}$ , direct impedance of the asynchronous motor [ $\Omega$ ].  
 $z_{backward}$ , inverse impedance of the asynchronous motor [ $\Omega$ ].  
 $z_i$ , input impedance of the asynchronous motor [ $\Omega$ ].  
 $rpm$ , rotation per minute.  
 $V_{min}$ , minimum source voltage [ $V$ ].  
 $V_{max}$ , maximum source voltage [ $V$ ].

#### *Variables*

$P_t(t)$ , thermal power (at time  $t$ ) [ $W$ ].  
 $P_e(t)$ , electric power (at time  $t$ ) [ $W$ ].  
 $T_{in}(t)$ , indoor air temperature (at time  $t$ ) [ $^{\circ}C$ ].  
 $T_{out}(t)$ , outdoor air temperature (at time  $t$ ) [ $^{\circ}C$ ].  
 $P_{loss}(t)$ , thermal power loss (at time  $t$ ) [ $W$ ].  
 $T_{hw}(t)$ , hot water temperature in the tank [ $^{\circ}C$ ].  
 $T_{hw,set}(t)$ , hot water set-point temperature for the tank [ $^{\circ}C$ ].  
 $T_{cw}(t)$ , inlet cold water temperature [ $^{\circ}C$ ].  
 $P(t)$ , output power (at time  $t$ ) [ $W$ ].  
 $I_1(t)$ , stator current of the asynchronous motor (at time  $t$ ) [ $A$ ].  
 $P_{loss,st}(t)$ , stator losses of the asynchronous motor (at time  $t$ ) [ $W$ ].  
 $P_m(t)$ , output mechanical power of the asynchronous motor (at time  $t$ ) [ $W$ ].  
 $P_f(t)$ , forecasted power production (at time  $t$ ) [ $W$ ].  
 $W_d(t)$ , average hot water draw per time [ $l/sec$ ].

- [1] N. Gudi, L. Wang, V. Devabhaktuni, S. S. S. R. Depuru, Demand response simulation implementing heuristic optimization for home energy management, in: North American Power Symposium 2010, 2010, pp. 1–6.
- [2] M. Deshmukh, S. Deshmukh, Modeling of hybrid renewable energy sys-

- tems, *Renewable and Sustainable Energy Reviews* 12 (1) (2008) 235 – 249.
- [3] M. Pipattanasomporn, M. Kuzlu, S. Rahman, Demand response implementation in a home area network: A conceptual hardware architecture, in: *2012 IEEE PES Innovative Smart Grid Technologies (ISGT)*, 2012, pp. 1–8.
  - [4] J. Peterson, *Petri net theory and the modeling of systems*, Prentice-Hall, 1981.
  - [5] D. F. Bender, B. Combemale, X. Crégut, J. M. Farines, B. Berthomieu, F. Vernadat, *Ladder Metamodeling and PLC Program Validation through Time Petri Nets*, Springer Berlin Heidelberg, Berlin, Heidelberg, 2008, pp. 121 – 136.
  - [6] H. Chaouch, J. B. H. Slama, Modeling and simulation of appliances scheduling in the smart home for managing energy, in: *2014 International Conference on Electrical Sciences and Technologies in Maghreb (CISTEM)*, 2014, pp. 1–5.
  - [7] M. P. Fantì, A. M. Mangini, M. Roccotelli, W. Ukovich, A district energy management based on thermal comfort satisfaction and real-time power balancing, *IEEE Transactions on Automation Science and Engineering* 12 (4) (2015) 1271–1284.
  - [8] C. Chen, J. Wang, Y. Heo, S. Kishore, Mpc-based appliance scheduling for residential building energy management controller, *IEEE Transactions on Smart Grid* 4 (3) (2013) 1401 – 1410.
  - [9] S. Prvara, J. Cigler, Z. Va, F. Oldewurtel, E. ekov, Use of partial least squares within the control relevant identification for buildings, *Control Engineering Practice* 21 (1) (2013) 113 – 121.
  - [10] H. Li, C. Zang, P. Zeng, H. Yu, Z. Li, N. Fenglian, Optimal home energy management integrating random pv and appliances based on stochastic programming, in: *2016 Chinese Control and Decision Conference (CCDC)*, 2016, pp. 429 – 434.
  - [11] J. Dong, A. A. Malikopoulos, S. M. Djouadi, T. Kuruganti, Application of optimal production control theory for home energy management in

- a micro grid, in: 2016 American Control Conference (ACC), 2016, pp. 5014 – 5019.
- [12] X. Wu, X. Hu, X. Yin, S. Moura, Stochastic optimal energy management of smart home with pev energy storage, *IEEE Transactions on Smart Grid PP (99)* (2016) 1–1. doi:10.1109/TSG.2016.2606442.
  - [13] R. Abaalkhail, M. Orozco, A. E. Saddik, Home energy saving for heating/cooling system by distributed intelligent energy controller, in: 2012 IEEE International Instrumentation and Measurement Technology Conference Proceedings, 2012, pp. 604–609.
  - [14] S. Li, D. Zhang, A. B. Roget, Z. O’Neill, Integrating home energy simulation and dynamic electricity price for demand response study, *IEEE Transactions on Smart Grid* 5 (2) (2014) 779–788.
  - [15] M. Franceschelli, A. Gasparri, A. Pisano, Coordination of electric thermal systems for distributed demand-side management: A gossip-based cooperative approach, in: 2016 European Control Conference (ECC), 2016, pp. 623–630.
  - [16] D. Zhang, S. Li, M. Sun, Z. O’Neill, An optimal and learning-based demand response and home energy management system, *IEEE Transactions on Smart Grid* 7 (4) (2016) 1790–1801.
  - [17] Z. Wang, R. Paranjape, Agent-based simulation of home energy management system in residential demand response, in: 2014 IEEE 27th Canadian Conference on Electrical and Computer Engineering (CCECE), 2014, pp. 1–6.
  - [18] T. Hansen, E. Chong, S. Suryanarayanan, A. Maciejewski, H. Siegel, A partially observable markov decision process approach to residential home energy management, *IEEE Transactions on Smart Grid PP (99)* (2016) 1–1. doi:10.1109/TSG.2016.2582701.
  - [19] Z. Yu, A. Dexter, Online tuning of a supervisory fuzzy controller for low-energy building system using reinforcement learning, *Control Engineering Practice* 18 (5) (2010) 532 – 539.

- [20] Y.-X. Lai, J. J. P. C. Rodrigues, Y.-M. Huang, H.-G. Wang, C.-F. Lai, An intercommunication home energy management system with appliance recognition in home network, *Mobile Networks and Applications* 17 (1) (2012) 132 – 142.
- [21] V. Pilloni, A. Floris, A. Meloni, L. Atzori, Smart home energy management including renewable sources: A qoe-driven approach, *IEEE Transactions on Smart Grid* PP (99) (2016) 1–1. doi:10.1109/TSG.2016.2605182.
- [22] C. Molitor, K. Togawa, S. Bolte, A. Monti, Load models for home energy system and micro grid simulations, in: 2012 3rd IEEE PES Innovative Smart Grid Technologies Europe (ISGT Europe), 2012, pp. 1–6.
- [23] P. Palensky, E. Widl, A. Elsheikh, Simulating cyber-physical energy systems: Challenges, tools and methods, *IEEE Transactions on Systems, Man, and Cybernetics: Systems* 44 (3) (2014) 318–326.
- [24] A. Ikpehai, B. Adebisi, Home energy management system over low-power narrowband plc, in: 2016 10th International Symposium on Communication Systems, Networks and Digital Signal Processing (CSNDSP), 2016, pp. 1–6.
- [25] M. P. Fanti, A. M. Mangini, M. Roccotelli, A petri net model for a building energy management system based on a demand response approach, in: 22nd Mediterranean Conference on Control and Automation, 2014, pp. 816–821.
- [26] Coefficients of performance: available at <http://www.powerknot.com/how-efficient-is-your-air-conditioning-system.html>.
- [27] E. Rathakrishnan, *Fundamentals of Engineering Thermodynamics*, PHI Learning, 2005.
- [28] M. Shaad, A. Momeni, C. P. Diduch, M. Kaye, L. Chang, Parameter identification of thermal models for domestic electric water heaters in a direct load control program, in: 2012 25th IEEE Canadian Conference on Electrical and Computer Engineering (CCECE), 2012, pp. 1–5.

- [29] P. Sen, Principles of Electric Machines and Power Electronics, John Wiley & Sons, November,2013.
- [30] Simscape tool: available at <https://www.mathworks.com/products/simscape.html>.
- [31] Lighting levels for us government buildings: available at <https://www.gsa.gov/portal/content/101308>.
- [32] Electricity meter manual: available at [http://www.asmb.it/export/sites/asmb/\\_downloads/it/energia-elettrica/informazioni/il-nuovo-contatore-elettronico.pdf](http://www.asmb.it/export/sites/asmb/_downloads/it/energia-elettrica/informazioni/il-nuovo-contatore-elettronico.pdf).