



Politecnico
di Bari

Repository Istituzionale dei Prodotti della Ricerca del Politecnico di Bari

Technical efficiency measures of industrial symbiosis networks using enterprise input-output analysis

This is a pre-print of the following article

Original Citation:

Technical efficiency measures of industrial symbiosis networks using enterprise input-output analysis / Fraccascia, Luca; Albino, Vito; Garavelli, Achille Claudio. - In: INTERNATIONAL JOURNAL OF PRODUCTION ECONOMICS. - ISSN 0925-5273. - STAMPA. - 183:(2017), pp. 273-286. [10.1016/j.ijpe.2016.11.003]

Availability:

This version is available at <http://hdl.handle.net/11589/126029> since: 2021-03-14

Published version

DOI:10.1016/j.ijpe.2016.11.003

Publisher:

Terms of use:

(Article begins on next page)

Technical exchange efficiency of industrial symbiosis networks using enterprise input-output analysis

Abstract

An important challenge that firms should be able to tackle regards the mitigation of the environmental impact of their production processes avoiding additional costs. Using industrial symbiosis (IS), two different firms can obtain mutual environmental and economic benefits, at the same time, exchanging wastes for primary inputs. Industrial symbiosis networks (ISNs), i.e. networks of firms and production processes exchanging wastes among them, are thus emerging and efficiency measures are needed to be defined and investigated, in order to drive the ISN design and development.

In this paper, we develop the concept of technical exchange efficiency of ISNs. A measure of such an efficiency is proposed. This measure is computed by using an input-output approach at the enterprise level to model symbiotic flows within ISNs. A case example is discussed in order to show the practical application of technical exchange efficiency of ISNs. In particular, technical exchange efficiency of ISNs can be useful in order to drive the development of existing ISNs and to design new industrial systems exploiting the IS approach.

Keywords: Industrial symbiosis, Industrial Symbiosis Networks, Technical efficiency, Enterprise Input-Output

1. Introduction

Industrial ecology is a concept that concerns the interactions between industrial activities and the environment (Graedel, 1994). In particular, industrial ecology analyses materials and energy flows in industry, the effect of these flows on the environment, and the way these flows are affected by economic, political, social, and legal factors (White, 1994).

Industrial symbiosis (IS) is a subfield of industrial ecology that engages separate industries in a collective approach to competitive advantage, involving physical exchange of materials, energy and services (Chertow, 2000). This approach allows to achieve economic, environmental, and social advantages for the firms involved and for the entire community (Mirata, 2004). The usefulness of the IS approach to boost resource use and production efficiency has been recognized by European Commission (2011), which has explicitly recommended its implementation. As a result, policymakers of many countries have introduced the IS practice in their environmental agenda (e.g., Mirata, 2004; Mirata and Emtairah, 2005; Van Berkel et al., 2009; Costa et al., 2010). Applications of IS are available in both developing and developed countries, confirming the

effectiveness of IS in pursuing eco-sustainable development (e.g., Sakr et al., 2011; Olayide, 2015). Various forms of IS have been recognized (Chertow, 2000, 2007) in terms of spatial scale (within a firm, among firms co-located, among firms not co-located), types of relationship (exchange of wastes and by-products, sharing of services and information), and planning approach (top down, bottom up). These IS forms are the result of the interaction among actors along three different dimensions: technical, economic, and social one.

An industrial symbiosis network (ISN) is a network of production processes among which IS relationships exist (Fichtner et al., 2004). ISNs can either be designed adopting a top-down approach or, conversely, let emerge from the bottom (Chertow, 2007). The cases of Kalundborg in Denmark and the National Industrial Symbiosis Programme (NISP) in United Kingdom demonstrate that both these approaches can be successful (Mirata, 2004; Jacobsen, 2006).

With the aim to better understand the potentialities of IS approach, several contributions analysing benefits generated by ISNs have been proposed by the literature (Chertow and Lombardi, 2005; Mattila et al., 2010; Sokka et al., 2011). In particular, the reduction in environmental impact of production processes and in costs generated for the firms involved has been quantified for different case studies. However, such an approach of analysis is unable to provide indications about the extent to which the IS is applied in an efficient manner within a given ISN, i.e. if the benefits currently generated could be further increased by better implementing the IS approach. Accordingly, a measure of efficiency for ISNs is lacking.

In this paper, we contribute to fill this gap by defining the concept of technical exchange efficiency of ISNs. A measure of the technical exchange efficiency is proposed adopting an input-output approach at the enterprise level (Lin and Polenske, 1998; Albino et al., 2002; Albino et al., 2003) to model production processes generating and requiring wastes, as well as the symbiotic exchanges taking place among these processes. A case example is used to show the computation of technical exchange efficiency and practical applications of such a measure. In particular, technical exchange efficiency of ISNs can be useful to drive the evolution of existing ISNs, as well as to design new industrial systems exploiting the IS approach.

The paper is organized as follow. Section 2 addresses the topic of IS. Section 3 develops the concept of technical exchange efficiency. In Section 4, the measure of technical exchange efficiency for a generic set of production processes exchanging wastes is developed and presented. Section 5 addresses and discusses the case example. Finally, conclusions are provided in Section 6.

2. Industrial symbiosis

The IS among production processes evokes the metaphor of natural symbiosis among organisms in ecosystems (Ayres, 1989; Korhonen, 2001). In this field, the word “symbiosis”, from ancient Greek σύν "together" and βίωσις "living", was coined by Albert Bernhard Frank in 1877, to indicate two species that live in close association with each other. Three subcategories of natural symbiosis have been identified (Douglas, 1994): mutualism, commensalism, and parasitism. In mutualistic symbiosis, the relationship between two organisms can be considered as a form of “biological barter”: one organism obtains at least one resource from the other organism in return for at least one service provided (Ollerton, 2006). Such an exchange allows that both the organisms benefit from symbiotic relationship because of their performance improvements. This situation does not occur in parasitism and commensalism, where only one organism benefits from the symbiotic relationship. This organism obtains nutrients or exploits services (for instance support or locomotion) provided by the other organism, without providing anything in return. The difference between the two subcategories is that, while in commensalism one organism benefits from symbiosis without affecting the performance of the other, in parasitism one organism benefits at the expense of the other, i.e. performance of the other organism is reduced (Table 1).

	Organism A	Organism B
Mutualism	Positive	Positive
Commensalism	Positive	None
Parasitism	Positive	Negative

Table 1. Impact on two organisms in each symbiosis subcategory.

In the IS context, production processes exchanging wastes for primary inputs correspond to natural organisms exchanging resources for services. Two production processes, A and B, implement a symbiotic relationship when at least one waste produced by the former is used to replace at least one primary input required by the latter (Lombardi and Laybourn, 2012). In such a case, the process B receives one resource (waste) from process A in return for a service provided (B is disposing wastes for A). Accordingly, IS can be conceptualized as a form of mutualistic symbiosis, since the relationship provides both the processes with environmental and economic benefits. In particular, from the environmental point of view, the amount of wastes disposed of in the landfill is reduced for process A, whereas the amount of primary inputs purchased from conventional sources is reduced for process B. Moreover, from the economical point of view, process A

benefits from reduction in waste disposal costs whereas process B benefits from reduction in primary input purchase costs (Esty and Porter, 1998; Albino and Fraccascia, 2015; Albino et al., 2016).

Literature has addressed the IS approach from technical, economical, and social point of view.

Two different cases of IS relationships can be recognized from the technical point of view: i) pure substitution between waste and primary input; ii) impure substitution between waste and primary input. Pure substitution occurs if a waste can be directly used in place of a primary input without any treatment process (Figure 1a). In the case of impure substitution, wastes need to be recycled before being used as inputs, i.e. some physical-chemical characteristics of the wastes have to be changed (Eilering and Vermeulen, 2004; Fichtner et al., 2005; Tudor et al., 2007). Hence, treatment processes making wastes suitable to be used as primary inputs have to be introduced. In carrying out this treatment, such processes may require additional primary inputs and energy and may generate additional wastes, in turn generating environmental impact (Figure 1b). However, the waste exchange is considered an IS process only if such an additional environmental impact is lower than the avoided one due to symbiotic exchange. Hence, although the need to treat wastes, the overall environmental benefits of IS relationships are positive (Mattila et al., 2010; Sokka et al., 2011; Mattila et al., 2012).

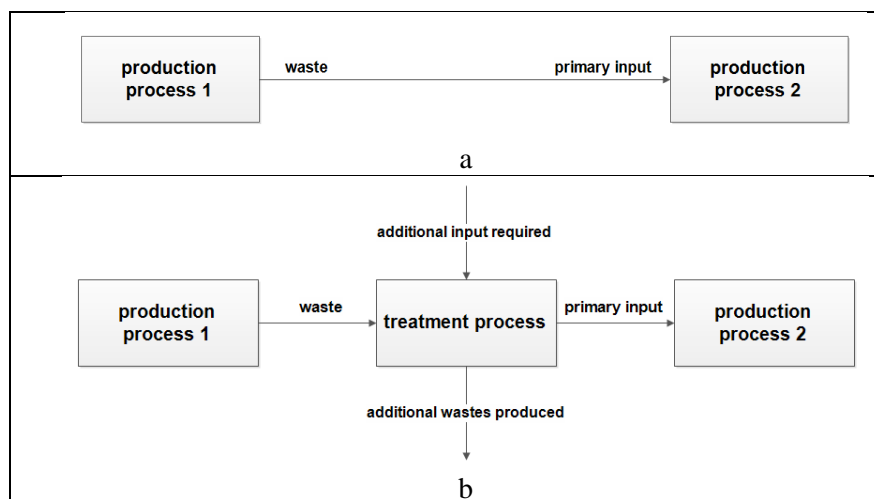

Figure 1. IS relationship with pure substitution between wastes and primary input (a) and IS relationship with impure substitution between wastes and primary input (b).

Literature recognized that the willingness to obtain economic benefit stemming from reduction in production costs or increase in revenues is the main driver that forces firms to implement IS (Esty and Porter, 1998; Lyons, 2007; Paquin et al., 2015). To establish an IS relationship, all the involved firms must achieve higher economic performance than in the absence of the relationship. Accordingly, IS relationships can arise

at several spatial levels and the choice of such a level is dominated by the transactions deriving from the economic logic of the firms involved (Lyons, 2007). Hence, IS relationships may also arise among production processes very far from each other until they are evaluated as economically convenient by all the involved firms (Sterr and Ott, 2004).

IS relationships may involve production processes belonging to the same firm or conversely belonging to different firms (Chertow, 2000). In the latter case, the effectiveness of IS can be negatively influenced by the diverging interests of involved actors, or by a missing collective action and cooperation (Eilering and Vermeulen, 2004). For this reason, IS has also been largely studied from the social point of view. Most of the literature agrees that trust and collaboration among the involved firms are the key factors for the preservation of IS relationships through time (e.g., Lambert and Boons, 2002; Hewes and Lyons, 2008). In fact, the success of IS is based on the individual perceptions of decision-makers, driven by their responsibilities and commitment on sustainable development (Posch, 2010). Mirata and Emtairah (2005) emphasized the importance of stimulating the collective definition of problems and of constructing inter-sectorial interfaces, and they defended the relevance of inter-organizational culture as a social component of IS. The development of measures able to point out the benefits and the opportunities of IS can strongly support the mutual understanding among all the actors involved.

Despite the importance of economic and social aspects in IS, we focus on technical one, since we evaluate it as a *conditio sine qua non* for the establishment of IS relationships. In particular, the technical aspect is related to the structure of symbiotic exchanges taking place among production processes. In the following section, we investigate the concept of efficiency related to how these exchanges are implemented.

3. Technical exchange efficiency of industrial symbiosis

This section is divided in two parts. In the former (Section 3.1), we investigate the concept of technical efficiency in industrial field, analysing its definition and measurement (Section 3.1.1) and how IS can affect such an efficiency (Section 3.1.2). In the latter, (Section 3.2), by exploiting the previous contribution, we develop the concept of technical exchange efficiency of IS.

3.1 Technical production efficiency in industrial context and the impact of industrial symbiosis on such an efficiency

3.1.1 Definition and measure of technical production efficiency

IS is implemented in the industrial context among production processes, each of them uses a given set of inputs to produce one or more outputs. In such a context, the concept of technical production efficiency can be considered (e.g. Agrell and Martin West, 2001; Ma et al., 2002; Kapelko et al., 2015). Such an efficiency can be defined for both a single production process and an industrial system composed by several production processes. In both cases, technical production efficiency addresses how the process/system transforms inputs into outputs. In this regard, let us consider a generic production process requiring two inputs, x and y , to produce a given output. All the combinations of productive factors that can be technically adopted to produce Π units of output are represented by the part of the Cartesian plane delimited at the bottom by the curve SS' in Figure 2. Accordingly, Π units of output can be indifferently produced by using Q_x units of input x and Q_y units of input y , by using $R_x > Q_x$ units of input x and $R_y < Q_y$ units of input y , or by using $P_x > Q_x$ units of input x and $P_y > Q_y$ units of input y .

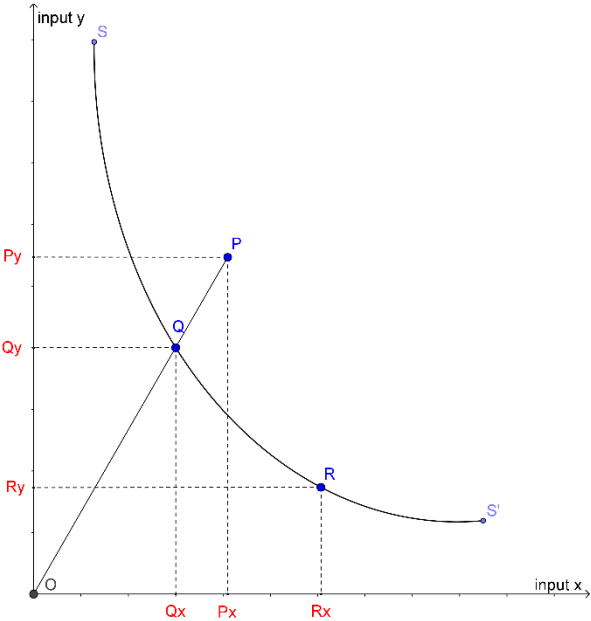

Figure 2. Graphical representation of the framework to evaluate technical production efficiency.

Koopmans (1951) first provided a formal definition of a production process technically efficient: “A producer is technically efficient if an increase in any output requires a reduction in at least one other output

or an increase in at least one input, and if a reduction in any input requires an increase in at least one other input or a reduction in at least one output". According to the Koopmans' definition, all the points on the curve SS' are technically efficient: in fact, for all these points, it is not technically possible to produce the same amount of output reducing the amount of input x (y) without increasing the amount of input y (x). For this reason, the curve SS' is defined as the efficient production frontier.

Let us assume now that the process would produce Π units of output using $P_x > Q_x$ units of input x and $P_y > Q_y$ units of input y (point P in Figure 2). According to the Koopmans' definition, such a point is not technically efficient, since the process could produce the same amount of output using lower amount of both inputs x and y . In this regard, the contributions of Debreu (1951) and Farrell (1957) allowed to develop a measure of technical production efficiency, known as the "Debreu-Farrell measure". Technical production efficiency of generic process can be measured as "one minus the maximum equiproportionate reduction in all inputs that still allows continued production of given outputs" (Lovell, 1993, p.10). According to this measure, all the efficient points have technical production efficiency equal to one. Of course, technical production efficiency of process denoted by the point P will be lower than one. It can be measured by using the following equation:

$$e = 1 - \left(\frac{\overline{QP}}{\overline{OP}} \right) \quad (1)$$

where \overline{QP} and \overline{OP} refer to the segments depicted in Figure 2. Hence, the higher the distance between the point P and the efficient production frontier (\overline{QP}), the lower the technical efficiency will be. Although this measure has been referred here to process/system with two inputs and one output, it can be easily extended to processes/systems with $N \geq 2$ inputs and $M \geq 2$ outputs (Farrell, 1957).

Firms are interested to adopt technically efficient production methods because, so doing, they minimize production costs. Moreover, the efficient production frontier can change over time, as a result of technological innovation in production methods (Färe et al., 1994). The amount of at least one input required to produce the same amount of output, *ceteris paribus*, can be reduced by such innovations. This case is depicted in Figure 3, where the new frontier is denoted as SS''. Because of innovation, it is now technically possible to produce Π units of output with $Q'_x < Q_x$ units of input x and $Q'_y < Q_y$ units of input y . Hence, the process denoted by the

point Q is no longer technically efficient and its current measure of technical production efficiency becomes lower than one.

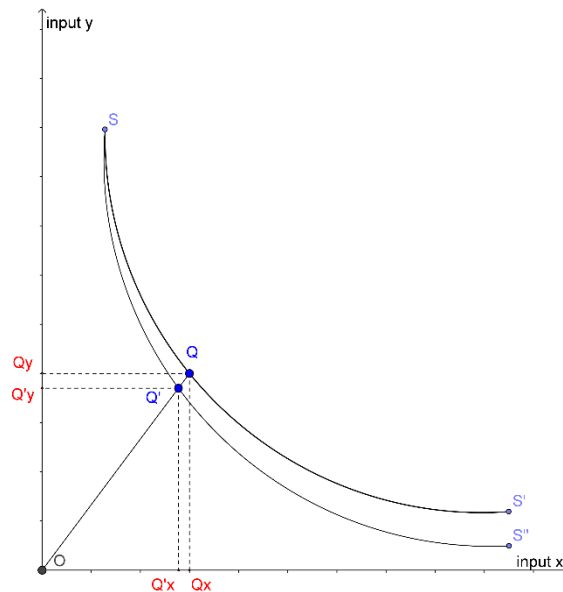

Figure 3. Effect of technological innovation on the efficient production frontier.

Firms are interested to innovate their production processes because, so doing, their economic performance is certainly improved. In fact, costs of inputs are reduced at equal revenues (when the same output is produced using lower inputs) or, conversely, revenues from outputs are increased at equal costs of inputs (when the same inputs allow to produce more output) (Farrell, 1957).

Moreover, as the environmental issue is gaining more attention, the definition of technical production efficiency can be extended considering wastes generated by production processes/systems as additional inputs (Rehinard et al., 1999; Kortelainen and Kuosmanen, 2004). Hence, at the same level of output, the efficient production frontier for a given process/system can be moved by two kinds of technological innovations: i) innovations allowing to reduce the amount of at least one required input, *ceteris paribus*; ii) innovations allowing to reduce the amount of at least one produced waste, *ceteris paribus*. Basing on the extended definition of technical efficiency, both these kinds of innovation improve the economic performance of the process/system, at the same time reducing its impact on the environment, *ceteris paribus*.

Then, technical production efficiency is related to the performance of the process/system: the efficiency can increase as the result of improvement in this performance. In particular, the efficiency is equal to one when the process/system has the highest reachable performance.

3.1.2 The impact of IS on technical production efficiency

When IS is implemented among processes belonging to an industrial system, the amount of wastes disposed of in the landfill as well as of inputs purchased from outside may be reduced. In such a case, some performance of the system can be enhanced.

Let us consider an industrial system composed by two production processes, A and B. For the sake of simplicity, let us assume that each process produces only one output (O(A) and O(B), respectively), requiring only one primary input (I(A) and I(B)) and producing only one waste (W(A) and W(B)) (Figure 4).

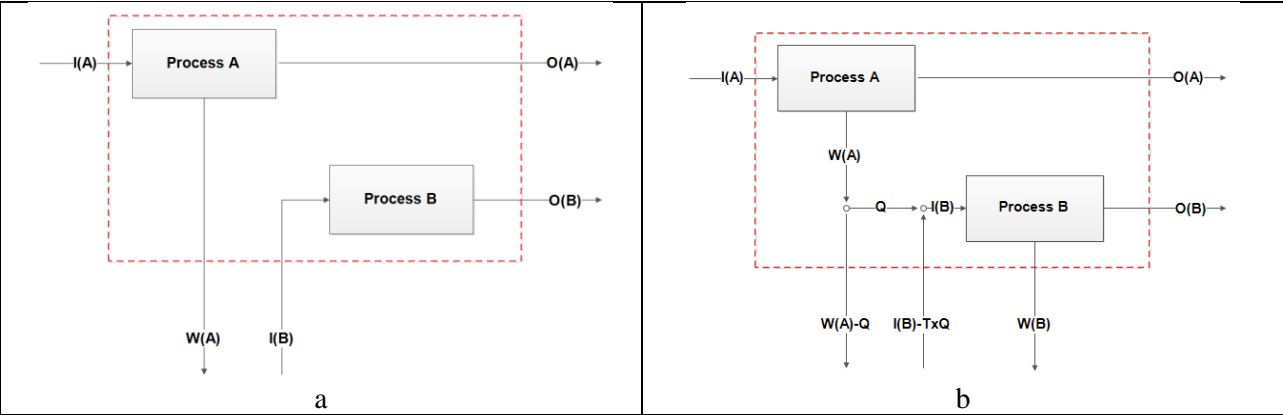

Figure 4. Industrial system composed by two production processes, when IS does not occur (a) and when IS occurs (b).

Let us assume that the system is perfectly efficient from technical point of view, i.e. that no inputs or wastes can be reduced at equal produced output (technical production efficiency of the system is equal to one). In particular, the amount of I(A) required and W(A) generated are directly proportional to the amount of O(A) produced. Similarly, the amount of I(B) required and W(B) generated are directly proportional to amount of O(B) produced. In such a system, there is no substitutability among productive factors, i.e. the current combination of required inputs and produced wastes is the only one able to produce the current amount of outputs. Hence, the efficient production frontier is composed by only one point, denoting the current status of the system in the space \mathbb{R}^4 (the number of dimensions is equal to the total number of inputs required and wastes produced by the system).

Let us assume now that feasibility conditions to replace I(B) with W(A) arise. Moreover, let us assume that one unit of W(A) is technically able to replace T units of I(B). Hence, Q units of waste produced by process A can be potentially used to replace TxQ units of input required by process B (Figure 4b). In this regard, two different cases may occur: pure substitution and impure substitution.

Pure substitution between $W(A)$ and $I(B)$. Let us consider the Cartesian plane where the x-axis denotes the amount of $W(A)$ disposed of in the landfill and the y-axis denotes the amount of $I(B)$ required from outside the system. For the sake of simplicity, we do not consider the other two dimensions ($I(A)$ and $W(B)$), since these parameters are not affected by the IS exchange. In such a plane, the point $N=(W(A), I(B))$ denotes the system when IS does not occur. When Q units of $W(A)$ are exchanged between processes, three different conditions may occur: i) $Q = \frac{I(B)}{T} < W(A)$. Such a case is denoted by the point $S=(W(A)-Q, 0)$ in Figure 5a: the system does not purchase any units of $I(B)$ from outside but it has to dispose of in the landfill $W(A)-Q$ units of $W(A)$; ii) $Q = W(A) < \frac{I(B)}{T}$. Such a case is denoted by the point $S=(0, I(B)-TxQ)$ in the Figure 5b: the system does not dispose of in the landfill any units of $W(A)$ but it has to purchase $I(B)-TxQ$ units of $I(B)$ from outside; and iii) $Q = W(A) = \frac{I(B)}{T}$. Such a case is denoted by the point O in the Figure 5c: the system does not purchase any units of $I(B)$ from outside and does not dispose of in the landfill any units of $W(A)$. The achievement of one of these three status depends on two parameters: i) the match between the produced amount of waste $W(A)$ and the required amount of input $I(B)$; and ii) the substitution rate T between waste and input. The angle α in Figure 5 is representative of this parameter: the higher T , the lower α will be, *ceteris paribus*¹.

¹ In fact, it results:

$$\alpha = \arccos \left\{ T \cdot \frac{I(B)}{\sqrt{[W(A) - Q]^2 + I(B)^2}} \right\} \quad \text{if } Q = \frac{I(B)}{T} < W(A) \text{ (Figure 5a)}$$

$$\alpha = \arccos \left\{ T \cdot \frac{I(B) - T \cdot Q}{\sqrt{W(A)^2 + [I(B) - T \cdot Q]^2}} \right\} \quad \text{if } Q = W(A) < \frac{I(B)}{T} \text{ (Figure 5b)}$$

$$\alpha = \arccos \left\{ T \cdot \frac{I(B)}{\sqrt{W(A)^2 + I(B)^2}} \right\} \quad \text{if } Q = W(A) = \frac{I(B)}{T} \text{ (Figure 5c)}$$

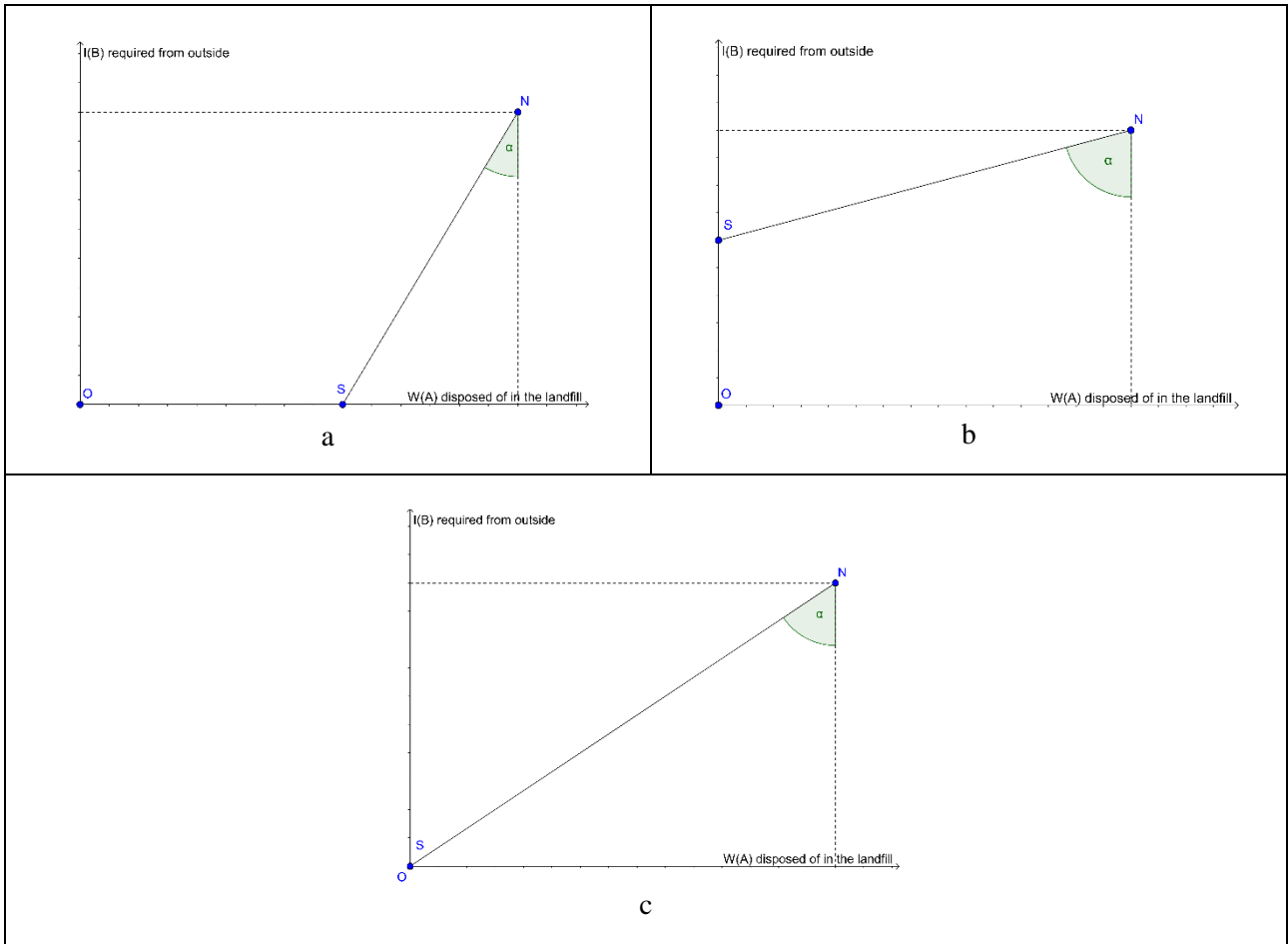

Figure 5. Effect of IS (when pure substitution occurs) on the efficient production frontier, in case: $Q = \frac{I(B)}{T} < W(A)$ (a), $Q = W(A) < \frac{I(B)}{T}$ (b), $Q = W(A) = \frac{I(B)}{T}$ (c).

Based on the definition of technical production efficiency, in all the three previous cases the system denoted by the point S is more efficient than the one denoted by the point N: in fact, at equal produced output, the amount of both W(A) disposed and I(B) purchased are lower than in the scenario without IS. This means that in all cases depicted in Figure 5, the efficient production frontier has moved due to IS. In fact, the system denoted by the point N, which was efficient before than IS became possible, is currently no longer efficient. Because of the Debreu-Farrell measure, the system denoted by the point S has now efficiency equal to one. All the points on the segment \overline{SN} become now technically attainable by the system. These points (except for the point S) have technical efficiency lower than one: in particular, the lower the distance from S, the higher the efficiency will be.

However, differently from the case in Figure 3, such a change of the efficient production frontier is not dependent on technological innovation reducing the amount of W(A) generated by process A and the amount of I(B) required by process B at equal produced output. In fact, the amount of both W(A) generated to produce O(A) and I(B) required to produce O(B) remain constant even when IS occurs, *ceteris paribus*. Instead, such

a change is due to the possibility provided by the IS to use part of generated $W(A)$ to replace part of required $I(B)$. Hence, in case of pure substitution between $W(A)$ and $I(B)$, production costs are of course reduced for both the processes: therefore, according to the economic logic driving the implementation of the IS approach, the system will implement IS, moving from point N to point S .

Impure substitution between $W(A)$ and $I(B)$. Let us consider now the case when impure substitution between $W(A)$ and $I(B)$ occurs. In such a case, we assume that $I(C)$ units of additional input are needed to exchange Q units of $W(A)$ between processes A and B . In the space depicted in Figure 6, the point $N=(W(A), I(B), 0)$ denotes the system when IS does not occur, whereas the point S denotes the system when IS occurs. In particular, three different cases may occur: i) $S=(W(A)-Q, 0, I(C))$ if $Q = \frac{I(B)}{T} < W(A)$ (Figure 6a); ii) $S=(0, I(B)-TxQ, I(C))$ if $Q = W(A) < \frac{I(B)}{T}$ (Figure 6b); and iii) $S=(0, 0, I(C))$ if $Q = W(A) = \frac{I(B)}{T}$ (Figure 6c).

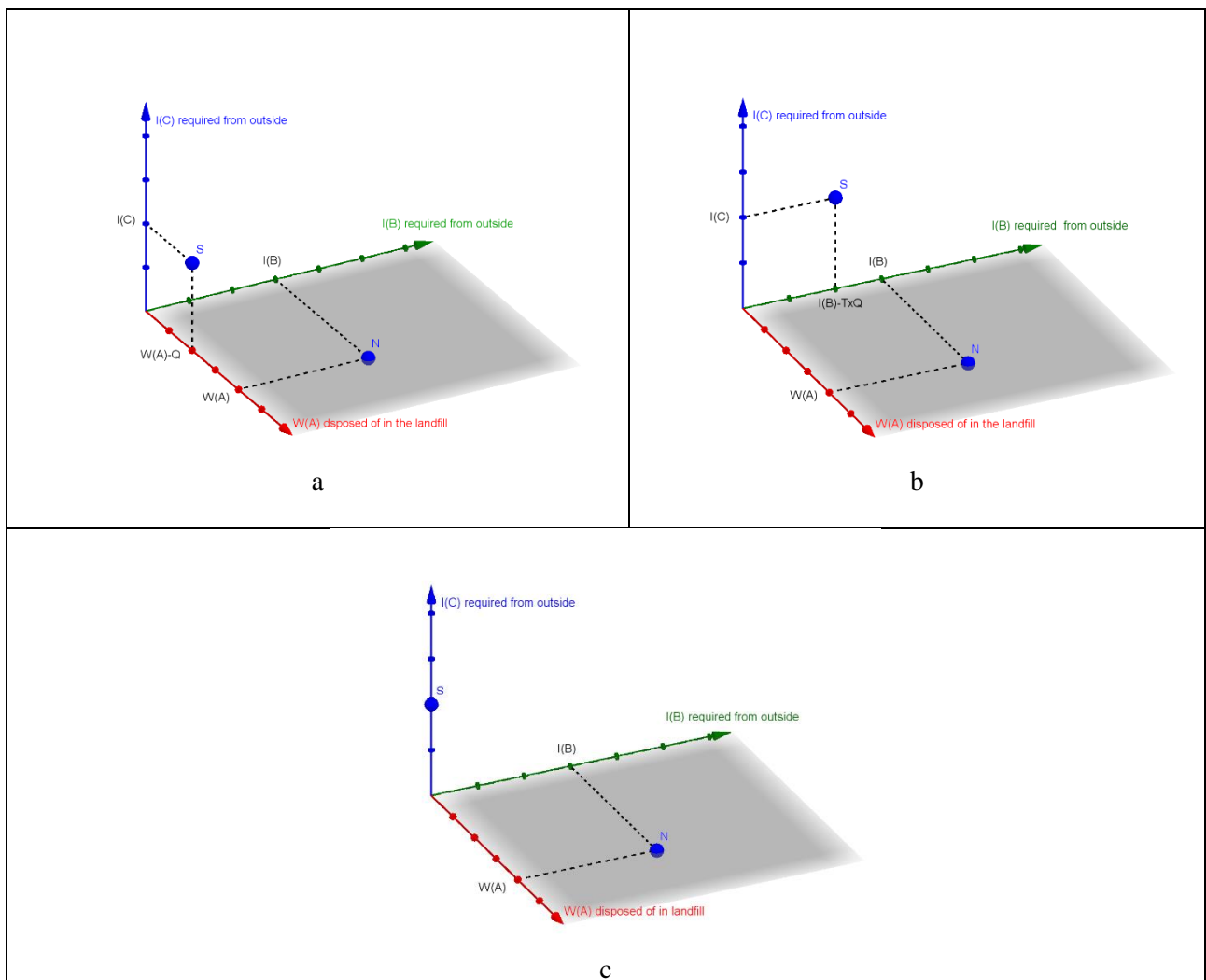

Figure 6. Effect of IS (when impure substitution occurs) on the efficient production frontier, in case: $Q = \frac{I(B)}{T} < W(A)$ (a), $Q = W(A) < \frac{I(B)}{T}$ (b), $Q = W(A) = \frac{I(B)}{T}$ (c).

Basing on the Koopmans' definition of technical production efficiency, we can argue that the systems denoted by points N and S in Figure 6 are characterized by the same efficiency. In fact, both W(A) disposed of in the landfill and I(B) purchased from outside are reduced by IS, but the symbiotic exchange requires additional input I(C), which is not required when IS does not occur. Hence, in case of impure substitution between W(A) and I(B), IS does not improve the technical production efficiency of the system. However, IS expands the space of production possibilities for the industrial system, making all the points on the segment \overline{NS} technically reachable by the system. This means that new combinations of production inputs are now available to produce the same amount of output. Nevertheless, on the contrary than the previous case, all the points denoting these combinations have the same technical production efficiency. Assuming that the advantage due to lower costs of input purchasing and waste disposing will be higher than the additional costs arising due to IS, the system will implement IS moving from point N to point S.

Pervious cases show that IS can affect two performance of ISNs: i) the amount of wastes disposed of in the landfill; and ii) the amount of primary inputs used by production processes. The higher the improvement in these performances, the higher the benefits provided by IS will be. Moreover, the improvement in these performances depend on how waste exchanges allow the match between waste supply and waste demand. For this reason, in defining the concept of efficiency related to IS, we refer to a technical exchange efficiency: such an efficiency focuses on waste exchanges among firms belonging to an ISN, evaluating the extent to which these exchanges are providing benefits.

Taking into account the previous contributions, in the next section we provide formal definition of technical exchange efficiency of IS and we propose a measure of such an efficiency.

3.2 The concept of technical exchange efficiency of IS

Let us consider an ISN when only one symbiotic exchange occurs, for instance the one depicted in Figure 4b. Assuming that replacing I(B) with W(A) is feasible from the environmental and economic point of view, the higher the amount of W(A) not disposed of in the landfill and the amount of I(B) not purchased from outside due to IS, the higher the benefits provided to the ISN by the IS approach will be. In particular, the highest benefits that such an exchange can provide are those arising when the overall amount of the produced

waste is not disposed of in the landfill and contemporaneously the overall amount of the required input is not purchased from outside the ISN because replaced by the waste. Therefore, we argue that the ISN is efficient from the symbiotic exchange point of view if, as a result of implementing IS among its processes, the ISN does not dispose of in the landfill any units of the exchanged wastes and, at the same time, does not purchase from outside any units of the replaced inputs. Such a condition has been defined as “perfect symbiosis” by Yazan et al. (2016). Therefore, as a corollary, we can argue that the ISN is efficient from the exchange point of view if perfect symbiosis occurs.

Let us consider the industrial system in Figure 4b. Such a system can be represented in the Cartesian plane where the x-axis denotes the amount of $W(A)$ disposed of in the landfill whereas the y-axis denotes the amount of $W(A)$ equivalent to the amount of $I(B)$ required by the ISN. In such a plane, the system when IS does not occur can be represented by the point $N=(W(A),I(B)/T)$. According to the definition of technical exchange efficiency, the ISN is efficient when $Q=W(A)=I(B)/T$. In such a case, the system will be denoted by the point $O=(0,0)$. Let us consider now the case where $Q=I(B)/T < W(A)$. Perfect symbiosis does not occur because the system has to dispose of in the landfill $W(A)-Q$ units of waste. The point denoting the system when symbiosis occurs is $S=(W(A)-Q,0)$. Perfect symbiosis would occur when, from the geometrical point of view, $S=O$: in such a condition, no difference between angles α and β in Figure 7 would occur ($\alpha=\beta$). Hence, the point S (ISN when symbiosis occurs) is much more distant from the point O (condition of perfect symbiosis) when $|\alpha-\beta|$ is higher. The segment \overline{PN} in Figure 7 is obtained by rotating the segment \overline{ON} by the angle $\beta-\alpha$ anticlockwise. It can be demonstrated that the segment \overline{PS} is proportional to $|\alpha-\beta|$: the higher the difference between α and β , the longer \overline{PS} will be. Such a framework can be used to propose a measure of technical exchange efficiency for the considered ISN defined by the following equation:

$$e = \frac{\overline{SN}}{\overline{ON}} \quad (2)$$

since $\overline{ON} = \overline{PN}$. Accordingly, technical exchange efficiency ranges between zero and one. In particular, it is equal to zero when symbiosis does not occur within the ISN ($S=N$ and therefore $\overline{SN} = 0$) whereas is equal to one when perfect symbiosis occurs ($S=O$ and therefore $\overline{SN} = \overline{SO}$). Moreover, the higher the distance between points S and P, the lower the technical exchange efficiency will be.

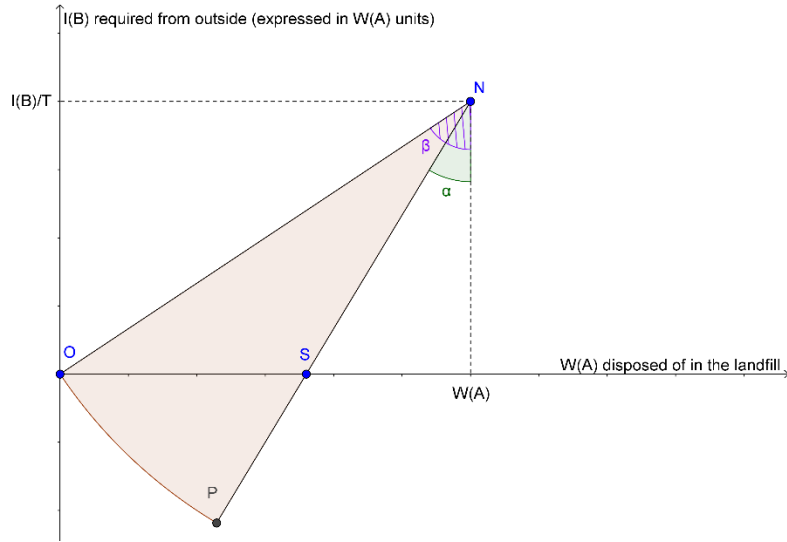

Figure 7. Graphical representation of the concept of technical exchange efficiency of IS.

Actually, the ISN depicted by point S is technically efficient from the production point of view but is not technically efficient from the symbiotic exchange point of view. This is due to the structure of the ISN, which does not allow the complete match between the amount of produced waste and the amount of required input. However, technical exchange efficiency can be increased by modifying the current structure of the ISN. In this regard, two kinds of structural changes can be implemented to increase technical exchange efficiency: i) reducing the amount of $W(A)$ produced within the ISN; and ii) increasing the amount of $I(B)$ required within the ISN. The former change can be obtained through technological innovation reducing the amount of $W(A)$ generated to produce one unit of output $O(A)$, *ceteris paribus*. The latter change can be obtained by increasing the amount of $O(B)$ produced, *ceteris paribus*. In both cases, we can observe that lower amount of $W(A)$ will be disposed of in the landfill. Moreover, from the geometrical point of view, $|\alpha - \beta|$ decreases.

It can be noted that one waste may replace more than one input within the ISN. In this regard, let us suppose that in a generic ISN $W(A)$ can indifferently replace the two inputs $I(B)$ and $I(C)$. In such a case, the overall amount of required inputs can be expressed in terms of the equivalent amount of $W(A)$. Hence, also this case can be depicted on the Cartesian plane shown in Figure 7. The point denoting the system when symbiosis does not occur will be $N = (W(A), I(B)/T_{AB} + I(C)/T_{AC})$, where T_{AB} and T_{AC} denote how many units of inputs $I(B)$ and $I(C)$ can be replaced by one unit of $W(A)$, respectively. Assuming that, when IS occurs, $W(A)$ replaces 40% of $I(B)$ and 50% of $I(C)$, the point denoting such a condition will be $S = (0, 0.4 * I(B)/T_{AB} + 0.5 * I(C)/T_{AC})$. Also in this case, technical exchange efficiency can be computed by using Equation (2).

Technical exchange efficiency of IS can be a useful tool to drive the evolution of the existing ISNs, aimed to improve the current performance of existing industrial systems. In addition, new industrial systems with high performance can be built by designing ISNs with high technical exchange efficiency, where production processes are highly integrated among them from the IS point of view. Such new systems based on IS approach can have lower environmental impact than the traditional ones since they are able to better use resources within them.

4. Measuring technical exchange efficiency for an industrial symbiosis network

In this section, we discuss about how to measure the technical exchange efficiency for a generic ISN composed by a given set of production processes.

In order to model the ISN, we use an input-output approach at the enterprise level. In particular, we first use the Enterprise Input-Output (EIO) model (Lin and Polenske, 1998; Albino et al., 2002; Albino et al., 2003) to shape primary input requirement and waste production by each production process. Then, we design the extension of the general EIO model to take into account also the symbiotic flows among production processes (Section 4.1). Afterwards, we show how to measure technical exchange efficiency by using data from the EIO model (Section 4.2).

4.1 Enterprise Input-Output model for ISNs

General EIO model. The EIO model describes the ISN as a network of production processes using an input–output approach. In general, a network of production processes consists of processes that procure materials and energy (primary inputs), transform them into outputs, and produce wastes. Two kinds of outputs can be produced: i) intermediate goods, destined to be used as input by other processes; ii) final goods for external markets. Hence, each process uses primary inputs from external markets and intermediate goods from other processes to produce outputs. Moreover, the wastes generated are disposed of in the landfill.

A generic ISN is made of n processes. For the sake of simplicity, we assume that each process produces only one main output. This output can be: i) all sold on final markets; ii) all used as intermediate good by other processes; and iii) in part sold on final markets and in part used as intermediate good by other processes. Hence,

each process has to produce output to satisfy: i) the final demand from external markets; and ii) the internal demand from other processes. In this regard, let f_0 be the $n \times 1$ vector of the final demand from external markets and x_0 the $n \times 1$ vector of gross outputs. Moreover, let Z_0 be the $n \times n$ matrix of the domestic intermediate deliveries, where the generic element Z_{0ij} denotes the amount of output produced by process i and used as intermediate good by process j . Then, the following identity holds:

$$x_0 = (I - Z_0 \cdot \hat{x}_0^{-1}) \cdot f_0 \quad (3)$$

where I is the $n \times n$ identity matrix and a “hat” is used to denote a diagonal matrix where $\hat{x}_{0ii} = x_{0i} \forall i$ and $\hat{x}_{0ij} = 0 \forall i \neq j$. In case of no flows of intermediate goods occur between processes ($Z_0 = \vec{0}$), the gross output of each process has only to satisfy the corresponding final demand ($x_0 = f_0$).

To produce its output, process i requires $n(r_i)$ primary inputs and generates $n(w_i)$ wastes (Figure 8). The network as a whole requires $n(r)$ primary inputs, with $n(r) \leq \sum_{i=1}^n n(r_i)$, and generates $n(w)$ wastes, with $n(w) \leq \sum_{i=1}^n n(w_i)$. Equality holds when either each primary input is used by only one process or each waste is produced by only one process, respectively.

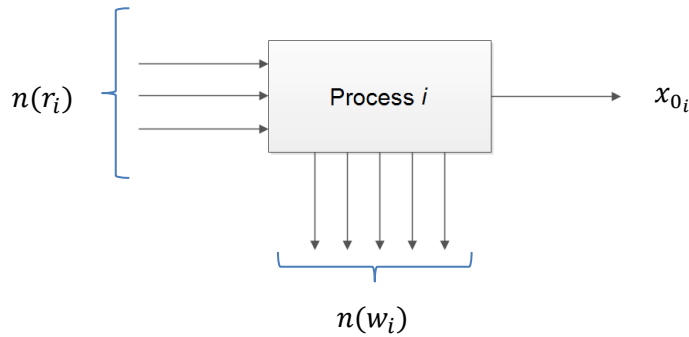

Figure 8. Graphical representation of a process in the ISN model.

Let r_0 be the $n(r) \times 1$ vector of primary inputs used in production processes and let w_0 be the $n(w) \times 1$ vector of wastes generated by production processes. Both primary inputs need and wastes production are related to the gross outputs by the following equations:

$$r_0 = R x_0 \quad (4)$$

$$w_0 = W x_0 \quad (5)$$

where the $n(r) \times n$ matrix of primary input coefficient R and the $n(w) \times n$ matrix of waste output coefficients W are obtained from observed data. The generic element R_{lj} denotes the quantity of primary input l required

to produce one unit of the output of process j . Similarly, the element W_{kj} denotes the quantity of waste k generated to produce one unit of the output of process j .

When a new final demand f ($n \times 1$) occurs for the ISN, we assume that matrices R and W remain constant. Then, we have a new gross output vector x ($n \times 1$) based on Equation (6) and, consequently, we can compute new vectors r ($n(r) \times 1$) and w ($n(w) \times 1$) from Equations (7) and (8).

$$x = (I - Z_0 \cdot \hat{x}_0^{-1}) \cdot f \quad (6)$$

$$r = Rx \quad (7)$$

$$w = Wx \quad (8)$$

EIO model for IS exchanges. When IS occurs, wastes of a process can be used to replace primary inputs in other processes. Then, in an ISN, processes can exchange among them intermediate goods and wastes for primary inputs. In particular, wastes of each production process can be either disposed of in the landfill or used as primary inputs by other processes. Each process can either purchase primary inputs from outside the ISN or use wastes from other processes as primary inputs. An ISN can be fully described if, for each production process, all the flows of primary inputs, intermediate goods, outputs, and wastes from and to both the other processes and the external markets are identified.

In order to model waste flows taking place among processes, for each couple of processes i and j we can define e^{ij} as the $n(w) \times 1$ vector of the observed symbiotic flows between i and j . The generic element e_k^{ij} denotes the amount of the k -th waste flowing from process i to process j .

Taking into account such a symbiotic exchange, two different cases may happen: i) pure substitution between waste k and primary input l ; ii) impure substitution between waste k and primary input l .

In case of pure substitution among waste and primary input, the waste can be directly used in place of primary input. If one unit of waste k generated by process i can replace P_{lk}^{ij} units of primary input l required by process j , e_k^{ij} units of waste k produced by process i replace $P_{lk}^{ij} \cdot e_k^{ij}$ units of primary input l in process j .

In case of impure substitution among waste and primary input, the waste has to be treated before being used as primary input. In the EIO approach, such a treatment is modelled as a process transforming wastes (input of treatment processes) in primary inputs (output of treatment processes). In Figure 9, the treatment process

transforming waste k generated by process i in primary input l required by process j is graphically depicted. Let RT_{pk}^{ij} be the amount of additional input p required to treat one unit of waste k and WT_{mk}^{ij} the amount of additional waste m generated by treating one unit of waste k . Hence, treating e_k^{ij} units of waste k requires $RT_{pk}^{ij} \cdot e_k^{ij}$ units of additional inputs p and generates $WT_{mk}^{ij} \cdot e_k^{ij}$ units of additional waste m .

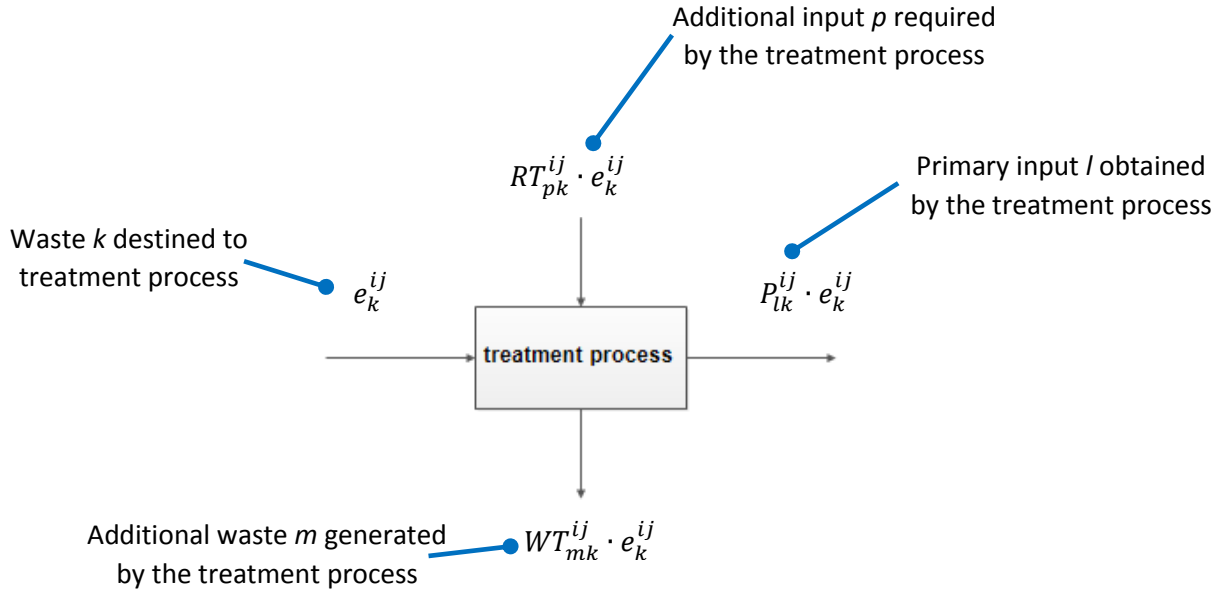

Figure 9. Graphical representation of the k -th waste treatment process in the ISN model.

Considering now the ISN as a whole, we can compute the environmental benefits due to the IS approach by using the EIO model. First, the $n(w) \times 1$ vector w^S of wastes saved, i.e. not disposed of in the landfill, is computed by using the following equation:

$$w^S = \sum_{i=1}^n \sum_{j=1}^n e^{ij} \quad (9)$$

Then, the $n(r) \times 1$ vector r^S of primary inputs saved, i.e. replaced by wastes and hence not purchased from outside the ISN, is computed by using the following equation:

$$r^S = \sum_{i=1}^n \sum_{j=1}^n P^{ij} \cdot e^{ij} \quad (10)$$

where P^{ij} is the $n(r) \times n(w)$ matrix denoting substitution rates among wastes produced by process i and primary inputs required by process j . The generic element P_{lk}^{ij} denotes how many units of primary input l are replaced by one unit of waste k .

Assuming that treatment processes generate tw additional wastes and require tr additional inputs, we can compute the $n(tw) \times 1$ vector of additional wastes generated (w^T) and the $n(tr) \times 1$ vector of additional inputs required (r^T) by the treatment processes by using the following equations:

$$w^T = \sum_{i=1}^n \sum_{j=1}^n WT^{ij} \cdot e^{ij} \quad (11)$$

$$r^T = \sum_{i=1}^n \sum_{j=1}^n RT^{ij} \cdot e^{ij} \quad (12)$$

where WT^{ij} is the $n(tw) \times n(w)$ matrix modelling waste generation by treatment processes and RT^{ij} is the $n(tr) \times n(w)$ matrix modelling input requirement by treatment processes.

Finally, let us consider the symbiotic exchange between processes i and j , where waste k replaces primary input l . In general, we highlight that the amount of exchanged waste cannot be higher than the amount of waste produced by process i . At the same time, such quantity cannot be higher than the correspondent amount of replaced input that is required by the process j . From numerical point of view, the following condition must be verified:

$$e_k^{ij} \leq \min \left\{ W_{ki} x_i, \frac{R_{lj}}{P_{kl}^{ij}} \cdot x_j \right\} \quad \forall (i, j, k, l), \quad P_{kl}^{ij} \neq 0 \quad (13)$$

4.2 Technical exchange efficiency measures

Let us consider the generic ISN where $n(w)$ wastes are exchanged. For the sake of simplicity in mathematical notation, let us assume that each waste is able to replace only one primary input. Hence, it results that $n(w) = n(r)$. Let w^E be the $n(w) \times 1$ vector of wastes equivalent to the input requirement. Such a vector is computed by using the following equation:

$$w^E = \left[\left(\sum_{i=1}^n \sum_{j=1}^n P^{ij} \right)^{-1} \right]^T \cdot (Rx) \quad (14)$$

where the generic element w_k^E denotes how many units of w_k are equivalent to the required amount of the input that waste k can replace.

Then, in the space $\mathbb{R}^{n(r)+n(w)} = \mathbb{R}^{2 \cdot n(w)}$ we can identify the point $N = (w_1, w_2, \dots, w_{n(w)}, w_1^E, w_2^E, \dots, w_{n(w)}^E)$, denoting the ISN when no symbiotic exchanges occur, and the point $S = (w_1 - w_1^S, w_2 - w_2^S, \dots, w_{n(w)} - w_{n(w)}^S, w_1^E - w_1^S, w_2^E - w_2^S, \dots, w_{n(w)}^E - w_{n(w)}^S)$, denoting the ISN when IS occurs. Technical exchange efficiency can be computed by using the following equation, which is the generalization in the multi-dimension space of the Equation (2):

$$e = \frac{|\overline{N - S}|}{|\overline{N - O}|} \quad (15)$$

where $\overline{N - O} = (w_1, w_2, \dots, w_{n(w)}, w_1^E, w_2^E, \dots, w_{n(w)}^E)$ and $\overline{N - S} = (w_1^S, w_2^S, \dots, w_{n(w)}^S, w_1^E - w_1^S, w_2^E - w_2^S, \dots, w_{n(w)}^E - w_{n(w)}^S)$.

Similarly to the case discussed in Section 3 for a two-dimension case, e values range between zero and one.

In particular, $e = 0$ when $S \equiv N$ whereas $e = 1$ when $S \equiv O$. Moreover, the higher $|\overline{N - S}|$, i.e., the lower the distance from the point O , *ceteris paribus*, the higher the technical exchange efficiency will be.

Using such a framework, we can decompose e in two further measures, which separately take into account the technical exchange efficiency for the wastes not disposed of in the landfill, e^w , and for the primary inputs saved, e^{PI} . Let us consider $\mathbb{R}^{n(w)}$ and $\mathbb{R}^{n(r)}$ as two vector subspaces of $\mathbb{R}^{n(w)+n(r)}$. In the former, the point $N_w = (w_1, w_2, \dots, w_{n(w)})$ has coordinates equal to the amount of all the produced wastes when IS does not occur, whereas the point $S_w = (w_1 - w_1^S, w_2 - w_2^S, \dots, w_{n(w)} - w_{n(w)}^S)$ has coordinates equal to the amount of the wastes disposed of in the landfill when IS occurs. Similarly, in the latter space, the point $N_{pi} = (w_1^E, w_2^E, \dots, w_{n(w)}^E)$ has coordinates equal to the amount of all primary inputs required by the ISN when IS does not occur, whereas the point $S_{pi} = (w_1^E - w_1^S, w_2^E - w_2^S, \dots, w_{n(w)}^E - w_{n(w)}^S)$ has coordinates equal to the amount of all primary inputs purchased from outside the ISN when IS occurs. e^w and e^{PI} can be computed by using the following equations:

$$e^W = \frac{|\vec{N}_w - \vec{S}_w|}{|\vec{N}_w - \vec{O}_w|} \quad (16)$$

$$e^{PI} = \frac{|\vec{N}_{pi} - \vec{S}_{pi}|}{|\vec{N}_{pi} - \vec{O}_{pi}|} \quad (17)$$

Both the measures range between zero and one. They are equal to zero when IS does not occur. In particular, e^W measures how ISN is efficient in reducing wastes disposal of in the landfill. It is equal to one when $S_w \equiv O_w$ i.e. when no wastes produced by the ISN are disposed of in the landfill, being recovered by symbiotic exchanges. Similarly, e^{PI} measures how ISN is technically efficient in reducing primary inputs purchasing from outside the network. This measure is equal to one when $S_{pi} \equiv O_{pi}$, i.e. when the primary inputs requirement of ISN is entirely satisfied by the wastes recovered within the network.

The efficiency measures previously identified can be also used to classify ISNs about their structural characteristics. Such a kind of classification is needed in order to understand how different structural attributes influence the exchanges of wastes and to better identify the strengths and weaknesses of a given ISN (Zhang et al., 2015). We identify three kinds of ISNs:

- **Waste absorbing ISNs.** They are characterized by $e^{PI} \ll e^W$ as the waste supply is much lower than the waste demand. Hence, the ISN has high performance in avoiding that wastes could be disposed of in the landfill but it shows low performance in saving the primary inputs (Figure 10a);
- **Primary input saving ISNs.** They are characterized by $e^{PI} \gg e^W$ as the waste supply is much higher than the waste demand. Hence, the ISN has high performance in saving the primary inputs but it shows low performance in avoiding that wastes could be disposed of in the landfill (Figure 10b);
- **Balanced ISNs.** They are characterized by $e^{PI} \cong e^W$ as there is an equilibrium between the waste supply and the waste demand. Hence, the ISN has quite similar performance in avoiding that wastes could be disposed of in the landfill and in saving the primary inputs (Figure 10c).

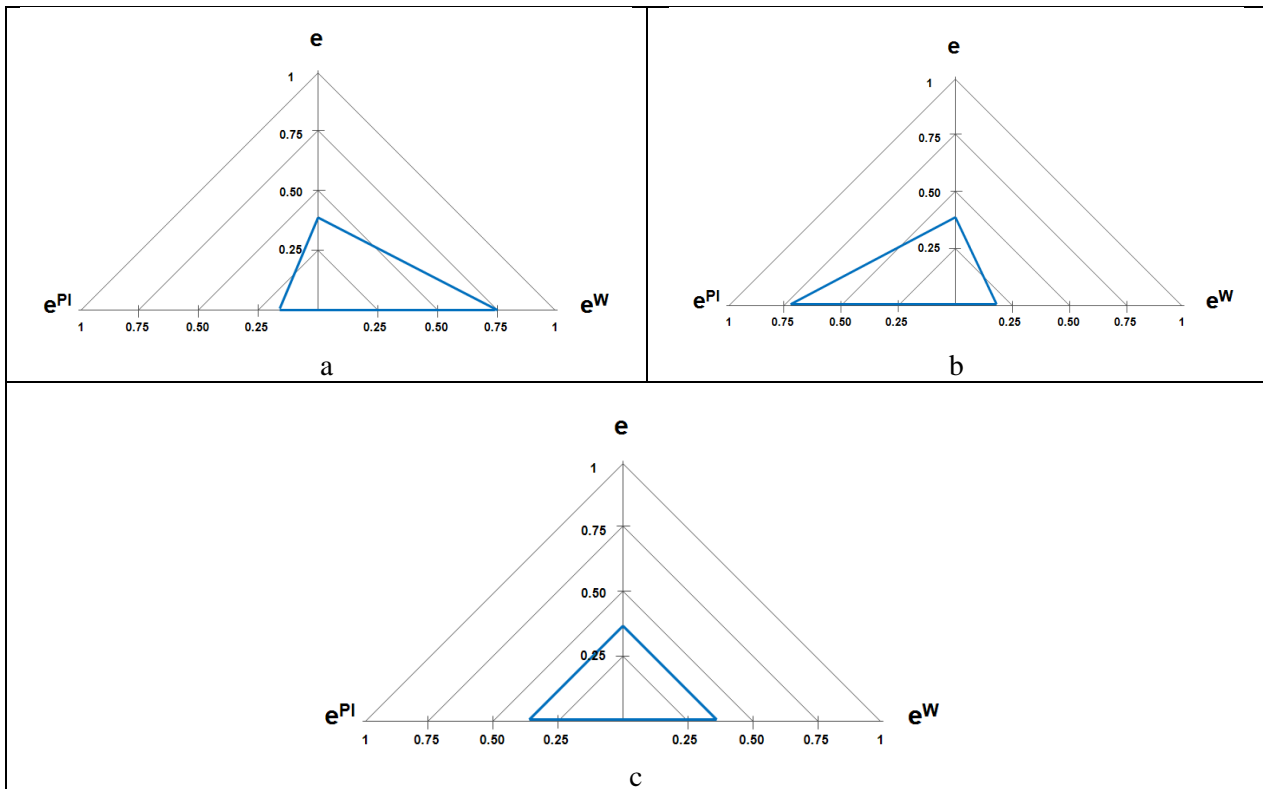

Figure 10. Graphical representation of the proposed ISN classification: (a) waste absorbing ISN; (b) primary input saving ISN; (c) balanced ISN. The same value of technical exchange efficiency can be obtained by ISNs with different e^W and e^{PI} .

5. Case example

In this section, we use a case example to show the computation of the technical exchange efficiency for a given ISN. Moreover, we show and discuss how such a measure can be useful to drive the evolution of the ISN.

5.1 Case description

The analysed ISN is composed by four production processes ($n=4$): exhausted tyres collection (process 1), cement production (process 2), synthetic grass production (process 3), and iron and steel production (process 4). No flows of intermediate goods occur among processes, so as the gross output of each process has only to satisfy the correspondent final demand. The gross output yearly generated by each process (vector x) is reported in Table 2.

Main product	Gross output
Exhausted tyres (x_1)	300 t
Cement (x_2)	3000 t
Synthetic grass (x_3)	300000 m ²
Iron and steel (x_4)	1000 t

Table 2. Observed gross output per year of each main product.

For the sake of simplicity, only wastes and primary inputs that can be involved in symbiotic exchanges are considered. The Process 1 generates two kinds of wastes from exhausted tyres collection: carcasses (w_1) and wheel rims (w_2). On the side of inputs, coal (r_1), resilient granules (r_2), and iron (r_3) are required by Process 2, Process 3, and Process 4, respectively. It results $n(w) = 2$ and $n(r) = 3$. Assuming that tyres consist in 50% carcass and 50% wheel rim, 0.5 tons of carcasses and 0.5 tons of wheel rims are produced for each ton of collected tyres. Moreover, producing 1 ton of cement requires 0.063 tons of coal, whereas producing 1 m² of synthetic grass requires $1.05 \cdot 10^{-4}$ tons of resilient granules (Albino and Yazan, 2013). Finally, we assume that 1 ton of iron is needed to produce 1 ton of steel. Hence, it results:

$$W = \begin{pmatrix} 0.5 & 0 & 0 & 0 \\ 0.5 & 0 & 0 & 0 \end{pmatrix} \quad R = \begin{pmatrix} 0 & 0.063 & 0 & 0 \\ 0 & 0 & 1.05 \cdot 10^{-4} & 0 \\ 0 & 0 & 0 & 1 \end{pmatrix}$$

According to Equations (7) and (8), the primary inputs required (vector r) and the wastes produced (vector w) are reported in Table 3.

		Process 1	Process 2	Process 3	Process 4
PRIMARY INPUT					
Coal	r_1		189 t		
Resilient granules	r_2			31.5 t	
Iron	r_3				1.000 t
WASTE					
Carcasses	w_1	150 t			
Wheel rims	w_2	150 t			

Table 3. Amount of required primary inputs and produced wastes by each process.

Carcasses can replace both coal and resilient granules. In this regard, the practice of substituting fossil fuels as coal with ground tires is widespread in the cement industry (Kääntee et al., 2004; Albino et al., 2011). Positive environmental effects of such a practice have been recognized in form of reducing net CO₂ and NO_x

emissions in comparison to fossil fuels (Cook and Kemm, 2004; European Cement Association, 2009; International Energy Agency, 2009). According to Corti and Lombardi (2004), 1 ton of tyres can replace 0,877 tons of coal. Moreover, the use of exhausted tyres as substitute of resilient granules in synthetic grass production is recognized as positive from environmental point of view. In this regard, 1 ton of exhausted tyres is assumed to replace 0,8 tons of resilient granules (Albino and Yazan, 2013). Finally, we assume one ton of wheel rim replaces one ton of iron. Accordingly, it results:

$$P^{12} = \begin{pmatrix} 0.877 & 0 \\ 0 & 0 \\ 0 & 0 \end{pmatrix} \quad P^{13} = \begin{pmatrix} 0 & 0 \\ 0.8 & 0 \\ 0 & 0 \end{pmatrix} \quad P^{14} = \begin{pmatrix} 0 & 0 \\ 0 & 0 \\ 0 & 1 \end{pmatrix}$$

For the sake of simplicity, we assume that pure substitution is possible for each symbiotic exchange.

The analyzed ISN is depicted in Figure 11, where only wastes and primary inputs that can be involved in symbiotic exchanges are represented.

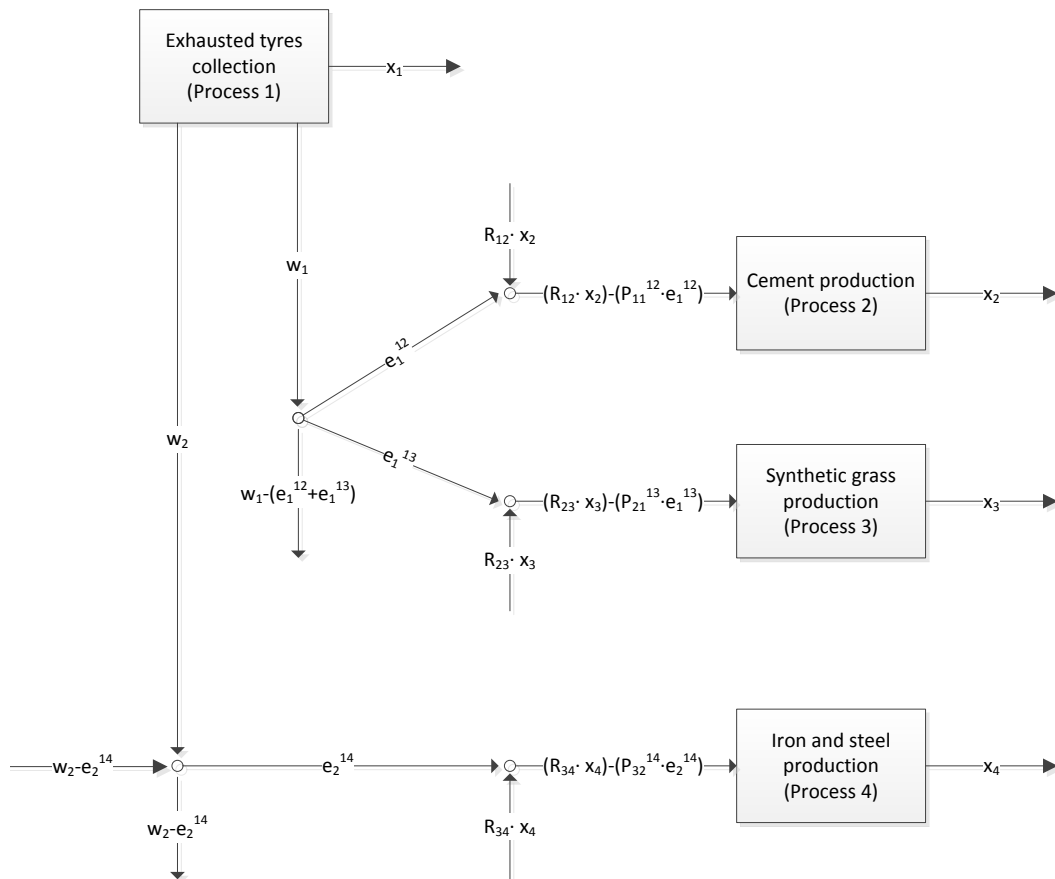

Figure 11. EIO graphical representation of the analysed ISN.

If the Process 1 choses the Process 2 as the first co-operator, then Process 2 will be supplied with priority. Accordingly, Process 1 will send 150 tons of carcasses to Process 2 whereas any tons of exhausted tyres will

be sent to Process 3. Moreover, the Process 1 sends 150 tons of wheel rims to Process 4. According to the EIO model in Section 4.1, it results:

$$e^{12} = \begin{pmatrix} 150 \\ 0 \end{pmatrix} \quad e^{13} = \begin{pmatrix} 0 \\ 0 \end{pmatrix} \quad e^{14} = \begin{pmatrix} 0 \\ 150 \end{pmatrix}$$

Hence, 150 tons of carcasses and 150 tons of wheel rims are not disposed of in the landfill due to IS. In fact, from Equation (9), it results:

$$w^S = e^{12} + e^{13} + e^{14} = \begin{pmatrix} 150 \\ 150 \end{pmatrix}$$

We can compute the amount of primary inputs saved using Equation (10). It results:

$$r^S = P^{12} \cdot e^{12} + P^{13} \cdot e^{13} + P^{14} \cdot e^{14} = \begin{pmatrix} 131.55 \\ 0 \\ 150 \end{pmatrix}$$

Accordingly, 131.55 tons of coal are replaced by carcasses and 150 tons of iron are replaced by wheel rims. The vector of wastes equivalent to primary input required can be computed by using Equation (14). It results:

$$w^E = [(P^{12} + P^{13} + P^{14})^{-1}]^T \cdot (R \cdot x) = \begin{pmatrix} 254.88 \\ 1000 \end{pmatrix}$$

This means that the overall amount of coal and resilient granules required within the ISN can be replaced by 254.88 tons of carcasses. Similarly, 1000 tons of wheel rims are required to replace all the iron used within the ISN.

In the vector space $\mathbb{R}^{n(w)+n(r)=2 \cdot n(w)}$ we can define the point $N=(150, 150, 254.88, 1000)$, denoting the ISN when IS does not occur, and the point $S=(0, 0, 104.88, 850)$, denoting the ISN when IS occurs. Technical exchange efficiency can be computed by using Equation (15). In this case, it results $\overrightarrow{N - S} = (150, 150, 150, 150)$ and $\overrightarrow{N - 0} = (150, 150, 254.88, 1000)$.

$$e = \frac{|\overrightarrow{N - S}|}{|\overrightarrow{N - 0}|} = \frac{300}{1053.55} = 0.2847$$

Efficiencies e^W and e^{PI} can be computed using Equations (16) and (17), respectively. It results $e^W = 1$ and $e^{PI} = 0.2056$. Graphical representation of the three measures is provided in Figure 12.

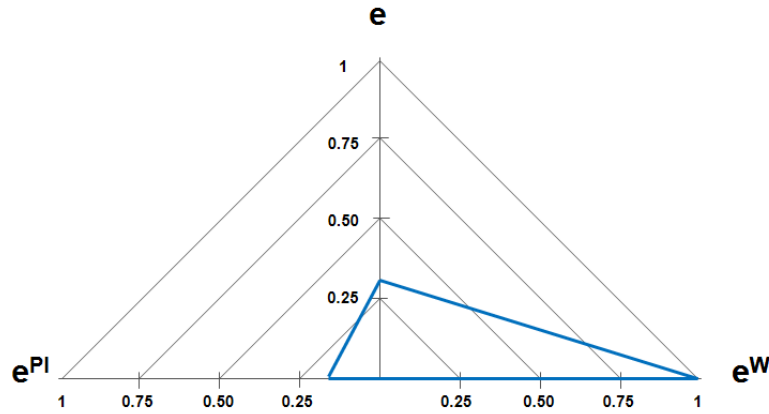

Figure 12. Graphical representation of the three efficiency measures for the analyzed ISN.

5.2 Discussion

The ISN has technical exchange efficiency equal to 0.2847. In particular, the ISN has high down-stream efficiency ($e^W = 1$), meaning that symbiotic exchanges are very effective in reducing the amount of wastes disposed of in the landfill. However, the up-stream efficiency is low ($e^{PI} = 0.2056$), meaning that low performance in reducing the amount of primary inputs purchased is achieved. In fact, nevertheless the 69.6% ($150 \cdot 0.877 / 189$) of coal is replaced by carcasses, no amount of synthetic grass is saved and only the 15% ($150 / 1000$) of the required iron is replaced by wheel rims. According to the classification proposed in section 4.2, this ISN can be actually considered as a “waste absorbing network”. Then, a strong difference between the amount of produced wastes and the amount of required primary inputs is observed.

Technical exchange efficiency can be increased by reducing such a difference. As the waste production is lower than the corresponding demand, the amount of wastes produced and exchanged within the ISN has to be increased. In turn, based on Equation (5), the amount of x_1 (collected tyres) has to be increased. In this regard, in Figure 13, the three measures of technical exchange efficiency are depicted as a function of the amount of collected tyres, *ceteris paribus*. Three different parts of the plane may be noted:

- As long as $x_1 \leq 500$ t, e^W remains equal to one and e^{PI} increases. This is because all the additional amount of produced wastes replaces primary inputs: hence, the amount of primary inputs purchased from outside the ISN is reduced. As an overall result, e increases;

- As long as $500 \text{ t} < x_1 \leq 2000 \text{ t}$, e continues to increase with lower growth rate. In particular, all the additional amount of wheel rims replaces iron in Process 4: therefore, since the amount of iron purchased from outside the ISN is reduced, e^{PI} increases. However, now the amount of produced carcasses has become higher than the correspondent demand. Therefore, part of produced carcasses has to be disposed of in the landfill. As a result, e^W decreases. As a whole, since the amount of disposed carcasses is lower than the amount of saved iron, e increases;
- When $x_1 > 2000 \text{ t}$, the demand of all the required primary inputs is entirely satisfied by the wastes available within the ISN: hence, e^{PI} becomes equal to one. However, the additional amount of both wastes produced have to be disposed of in the landfill: therefore, e^W decreases, causing that also e decreases.

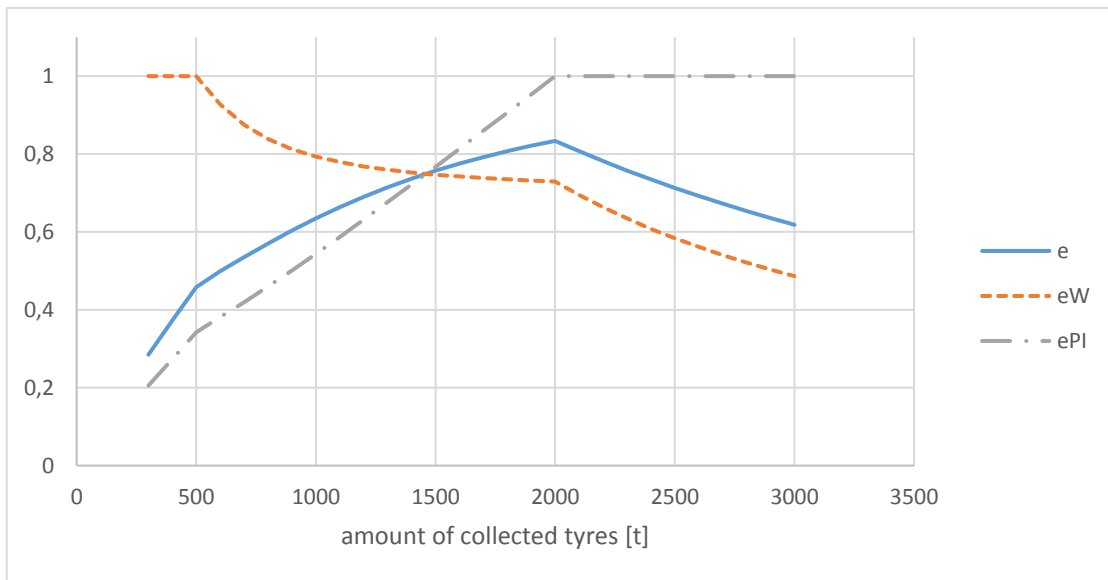

Figure 13. Technical exchange efficiency (e), down-stream efficiency (e^W), and up-stream efficiency (e^{PI}) of the ISN as a function of the amount of collected tyres.

Figure 13 also shows that increasing the amount of collected tyres, *ceteris paribus*, does not allow the ISN to achieve the condition of perfect symbiosis. In fact, the highest level of e achievable is lower than one. Perfect symbiosis occurs when the amount of each produced waste has to be equal to the correspondent amount demanded. Such a condition can be formalized by the following system of equations (Yazan et al., 2016):

$$\begin{cases} w_1 = r_1 + r_2 \Rightarrow W_{11}x_1 = \frac{R_{12}x_2}{P_{11}} + \frac{R_{23}x_3}{P_{12}} \\ w_2 = r_3 \Rightarrow W_{21}x_1 = \frac{R_{34}x_4}{P_{23}} \end{cases} \quad (18)$$

In particular, W_{11} , R_{12} , P_{11} , R_{23} , P_{12} , W_{21} , R_{34} , and P_{23} are constant. Hence, solving for x , it results:

$$\begin{cases} 0.5x_1 = 0.0718x_2 + 1.31 \cdot 10^{-4}x_3 \\ 0.5x_1 = x_4 \end{cases}$$

In this case, ∞^2 solutions exist. In Table 4, one of the possible solutions (for instance, that obtained by defining *a priori* the levels of x_3 and x_4) is shown.

Process	New final demand	Variation rather the current situation
1	6000 t	+ 5700 t
2	41200 t	+ 38210 t
3	300000 m ²	+ 0 m ²
4	3000 t	+ 2000 t

Table 4. Final demand for each production process which ensure the perfect symbiosis among processes.

Based on this solution, final demands of Processes 1, 2, and 4 have to be increased by 5700 t, 38210 t, and 2000 t, respectively, rather than the current levels. Such an increase could be obtained by adopting two different strategies: i) creating additional demand for outputs produced by firms currently involved in the ISN; and ii) including new firms within the ISN with the same production processes than those currently involved (tyres collection, cement production, steel production). Alternatively, final demand of process 3 does not need to be increased. Figure 14 shows the current values of efficiency (blue line) as well as the highest value achievable (green lines).

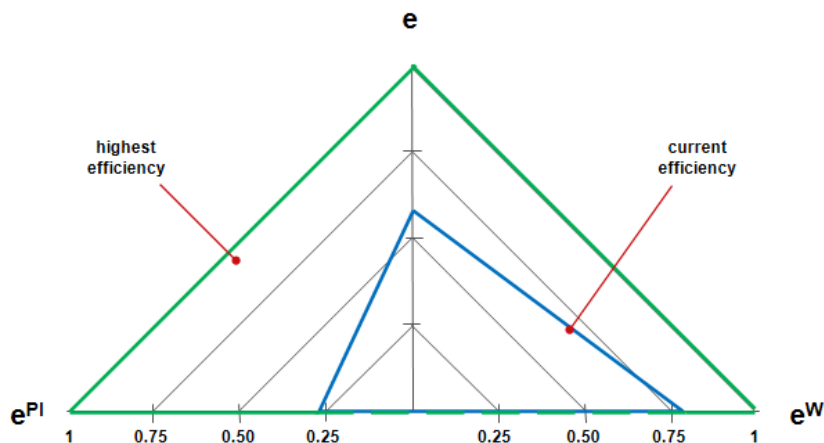

Figure 14. Graphical comparison between current efficiency (blue line) and highest efficiency achievable (green line).

Finally, notice that the condition of perfect symbiosis can be achieved by this ISN because the system in Equation (18) is solvable under the constraint that none of the x is equal to zero. In fact, a given x equal to zero

means that the correspondent process has to be eliminated from the ISN. Alternatively, if the system cannot be solved under such a constraint, the condition of perfect symbiosis cannot be achieved. In this regard, let us consider for instance the ISN depicted in Figure 15, where a symbiotic exchange closed-loop exists, i.e., waste from Process A is used by Process B and waste from Process B is used by Process A.

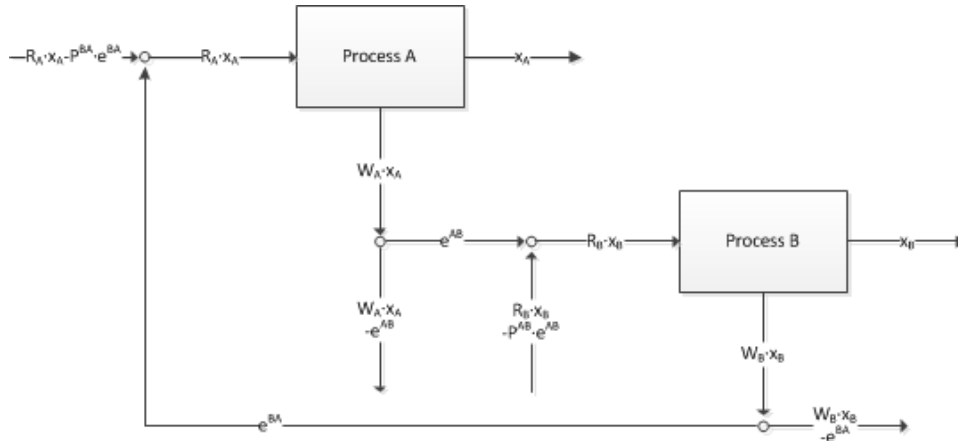

Figure 15. Graphical comparison between current efficiency (blue line) and highest efficiency achievable (green line).

The condition of perfect symbiosis can be mathematically described by the following equation system:

$$\begin{cases} P^{AB} \cdot W_A \cdot x_A - R_B \cdot x_B = 0 \\ -P^{BA} \cdot R_A \cdot x_A + W_B \cdot x_B = 0 \end{cases}$$

In particular, such a condition can be achieved if and only if $\frac{R_B}{P^{AB} \cdot W_A} = \frac{P^{BA} \cdot W_B}{R_A}$. Alternatively, if such an identity is not verified, the only solution for the system will be $x_A = x_B = 0$: therefore, perfect symbiosis cannot be achieved by this ISN, due to the current structure of symbiotic exchanges.

6. Conclusions

IS is recognized as a useful approach to boost resource use in industrial systems, generating environmental and economic advantages. However, such an approach lacks of efficiency measures, able to compare the current performance of ISNs with the highest performance achievable, providing indications about how to improve the current performance raising in turn benefits generated by IS relationships.

In this paper, we propose the concept of technical exchange efficiency of ISNs, measuring how efficiently the symbiotic exchanges among processes in ISNs occur. Technical exchange efficiency of ISNs is maximized when there is perfect balance between the amount of produced wastes and the amount of required primary inputs, i.e. when perfect symbiosis occurs within the ISN. Increasing the technical exchange efficiency of a given ISN may allow to increase the technical production efficiency of that ISN, i.e. the efficiency with which the industrial system uses resources and produces wastes. In fact, we showed that the effect of implementing IS among a given set of production processes is the same of technological innovations on each of the involved process, able to reduce the amount of at least one required input or at least one produced waste at equal input generated. Therefore, increasing technical exchange efficiency allows to fully exploit the potentialities of IS in generating advantages for firms involved and for the collectivity. For this reason, it is important that ISNs will be characterized by high technical exchange efficiency.

To support the efficiency evaluation, we designed a measure of technical exchange efficiency based on an enterprise input-output model. Such a measure ranges between zero and one: it is equal to zero when no symbiosis occurs in the ISN whereas it is equal to one when perfect symbiosis occurs. Low value of technical exchange efficiency is due to misalignment between the amount of wastes produced and the amount of correspondent inputs required. In this regard, the up-stream and down-stream efficiency measures help to better identify the cause. In particular, the up-stream efficiency is low when waste supply is lower than demand, i.e. when high quantity of inputs has to be purchased from outside the ISN. On the contrary, when waste supply is higher than demand, i.e. high quantity of wastes has to be disposed of in the landfill, the down-stream efficiency is low.

The proposed measure of technical exchange efficiency can be useful for different purposes. It can be used as a communication tool conveying information to firms and stakeholders about the extent to which IS is currently providing benefits rather than its potential one. In addition, it can be useful in driving and planning the evolution of ISNs. By measuring technical exchange efficiency, the mismatches between demand and supply of each exchanged waste can be easily discovered. Afterwards, strategies aimed to reduce these mismatches can be designed by using the EIO model. The proposed strategies can address changes in the amount of output of involved firms or the evolution of the ISN structure by adding new firms within the ISN. Despite all these strategies can be designed by using the EIO model, it can be noted that such a model does not

provide any indications about which is the best strategy from the environmental or economic point of view. In order to overcome this limit, additional measures providing such an information should be considered in the analysis. In this regard, measures of efficiency able to characterize each exchanged waste on the basis of its environmental impact and economic value are a subject for future research.

References

- Agrell, P.J., Martin West, B., 2001. A caveat on the measurement of productive efficiency. *International Journal of Production Economics* 69, 1–14. doi:10.1016/S0925-5273(00)00036-0.
- Albino, V., Izzo, C., Kühtz, S., 2002. Input–output models for the analysis of a local/global supply chain. *International Journal of Production Economics* 78, 119–131. doi:10.1016/S0925-5273(01)00216-X.
- Albino, V., Dietzenbacher, E., Kühtz, S., 2003. Analysing Materials and Energy Flows in an Industrial District using an Enterprise Input–Output Model. *Economic Systems Research* 15, 457–480. doi:10.1080/0953531032000152326.
- Albino, V., Dangelico, R.M., Natalicchio, A., Yazan, D.M., 2011. Alternative energy sources in cement manufacturing. A Systematic Review of the Body of Knowledge. <http://nbs.net/wp-content/uploads/NBS-Systematic-Review-Cement-Manufacturing.pdf>
- Albino, V., Yazan, D.M., 2013. Economic and environmental benefits of industrial symbiosis. An enterprise input-output analysis. 21st International Input-Output Conference, Kitakyushu, Japan, July 9-12.
- Albino, V., Fraccascia, L., 2015. The industrial symbiosis approach: a classification of business models. *Procedia Environmental Science, Engineering and Management*, 2(3), 217–223.
- Albino, V., Fraccascia, L., Giannoccaro, I., 2016. Exploring the role of contracts to support the emergence of self-organized industrial symbiosis networks: an agent-based simulation study. *Journal of Cleaner Production* 112, 4353–4366. doi:10.1016/j.jclepro.2015.06.070.
- Ayres, R.U., 1989. Industrial metabolism. *Technology and environment* 1989, 23-49.
- Chertow, M.R., 2000. Industrial Symbiosis: Literature and Taxonomy. *Annual Review of Energy and the Environment* 25, 313–337. doi:10.1146/annurev.energy.25.1.313.
- Chertow, M.R., 2007. “Uncovering” Industrial Symbiosis. *Journal of Industrial Ecology* 11, 11–30. doi:10.1162/jiec.2007.1110.
- Chertow, M.R., Lombardi, D.R., 2005. Quantifying Economic and Environmental Benefits of Co-Located Firms. *Environmental Science & Technology* 39, 6535–6541. doi:10.1021/es050050+.
- Cook, A., Kemm, J., 2004. Health impact assessment of proposal to burn tyres in a cement plant. *Environmental Impact Assessment Review* 24, 207-216.
- Corti, A., Lombardi, L., 2004. End life tyres: Alternative final disposal processes compared by LCA. *Energy* 29, 2089–2108. doi:10.1016/j.energy.2004.03.014.

- Costa, I., Massard, G., Agarwal, A., 2010. Waste management policies for industrial symbiosis development: case studies in European countries. *Journal of Cleaner Production* 18, 815–822. doi:10.1016/j.jclepro.2009.12.019.
- Debreu, G., 1951. The Coefficient of Resource Utilization. *Econometrica* 19, 273–292. doi:10.2307/1906814.
- Douglas, A.E., 1994. *Symbiotic Interactions*. Oxford University Press.
- Eilering, J.A.M., Vermeulen, W.J.V., 2004. Eco-industrial parks: toward industrial symbiosis and utility sharing in practice. *Progress in Industrial Ecology, an International Journal* 1, 245–270. doi:10.1504/PIE.2004.004681.
- Esty, D.C., Porter, M.E., 1998. Industrial Ecology and Competitiveness. *Journal of Industrial Ecology* 2, 35–43. doi:10.1162/jiec.1998.2.1.35.
- European Cement Association, 2009. Sustainable cement production: co-processing of alternative fuels and raw materials in the cement industry.
- European Commission, 2011. Communication from the Commission to the European Parliament, the Council, the European Economic and Social Committee and the Committee of the regions. Roadmap to a Resource Efficiency Europe, Bruxelles: European Commission.
- Färe, R., Grosskopf, S., Norris, M., Zhang, Z., 1994. Productivity growth, technical progress, and efficiency change in industrialized countries. *The American economic review* 84, 66-83.
- Farrell, M.J., 1957. The Measurement of Productive Efficiency. *Journal of the Royal Statistical Society. Series A (General)* 120, 253–290. doi:10.2307/2343100.
- Fichtner, W., Tietze-Stöckinger, I., Frank, M., Rentz, O., 2005. Barriers of interorganisational environmental management: two case studies on industrial symbiosis. *Progress in Industrial Ecology, an International Journal* 2, 73–88. doi:10.1504/PIE.2005.006778.
- Graedel, T., 1994. Industrial Ecology: Definition and Implementation, in: Solocow, R., Andrews, C., Berkhout, F., Thomas, V. (Eds), *Industrial Ecology and Global Change*. Cambridge University Press.
- Hewes, A.K., Lyons, D.I., 2008. The Humanistic Side of Eco-Industrial Parks: Champions and the Role of Trust. *Regional Studies* 42, 1329–1342. doi:10.1080/00343400701654079.
- International Energy Agency, 2009. Cement Technology Roadmap 2009. Carbon emissions reductions up to 2050. <https://www.iea.org/publications/freepublications/publication/Cement.pdf>
- Jacobsen, N.B., 2006. Industrial Symbiosis in Kalundborg, Denmark: A Quantitative Assessment of Economic and Environmental Aspects. *Journal of Industrial Ecology* 10, 239–255. doi:10.1162/108819806775545411.
- Kääntee, U., Zevenhoven, R., Backman, R., Hupa, M., 2004. Cement manufacturing using alternative fuels and the advantages of process modelling. *Fuel Processing Technology* 85, 293–301. doi:10.1016/S0378-3820(03)00203-0.
- Kapelko, M., Horta, I.M., Camanho, A.S., Oude Lansink, A., 2015. Measurement of input-specific productivity growth with an application to the construction industry in Spain and Portugal. *International Journal of Production Economics* 166, 64–71. doi:10.1016/j.ijpe.2015.03.030

- Korhonen, J., 2001. Four ecosystem principles for an industrial ecosystem. *Journal of Cleaner Production* 9, 253–259. doi:10.1016/S0959-6526(00)00058-5.
- Koopmans, T.C., 1951. Analysis of production as an efficient combination of activities, in: *Activity analysis of production and allocation*. John Wiley & Sons.
- Kortelainen, M., Kuosmanen, T., 2004. Data envelopment analysis in environmental valuation: environmental performance, eco-efficiency and cost-benefit analysis (No. 21). Working Paper: ISBN 952-458-528-6 ISSN 1458-686X.
- Lambert, A.J.D., Boons, F.A., 2002. Eco-industrial parks: stimulating sustainable development in mixed industrial parks. *Technovation* 22, 471–484. doi:10.1016/S0166-4972(01)00040-2.
- Lin, X., Polenske, K.R., 1998. Input–output modeling of production processes for business management. *Structural Change and Economic Dynamics* 9, 205–226. doi:10.1016/S0954-349X(97)00034-9.
- Lombardi, D.R., Laybourn, P., 2012. Redefining Industrial Symbiosis. *Journal of Industrial Ecology* 16, 28–37. doi:10.1111/j.1530-9290.2011.00444.x.
- Lovell, C.K., 1993. Production frontiers and productive efficiency, in *Production frontiers and productive efficiency. The measurement of productive efficiency: techniques and applications*. Oxford University Press.
- Lyons, D.I., 2007. A Spatial Analysis of Loop Closing Among Recycling, Remanufacturing, and Waste Treatment Firms in Texas. *Journal of Industrial Ecology* 11, 43–54. doi:10.1162/jiec.2007.1029.
- Ma, J., Evans, D.G., Fuller, R.J., Stewart, D.F., 2002. Technical efficiency and productivity change of China's iron and steel industry. *International Journal of Production Economics* 76, 293–312. doi:10.1016/S0925-5273(01)00195-5
- Mattila, T.J., Pakarinen, S., Sokka, L., 2010. Quantifying the Total Environmental Impacts of an Industrial Symbiosis - a Comparison of Process-, Hybrid and Input–Output Life Cycle Assessment. *Environmental Science & Technology* 44, 4309–4314. doi:10.1021/es902673m.
- Mattila, T.J., Lehtoranta, S., Sokka, L., Melanen, M., Nissinen, A., 2012. Methodological Aspects of Applying Life Cycle Assessment to Industrial Symbioses. *Journal of Industrial Ecology* 16, 51–60. doi:10.1111/j.1530-9290.2011.00443.x.
- Mirata, M., 2004. Experiences from early stages of a national industrial symbiosis programme in the UK: determinants and coordination challenges. *Journal of Cleaner Production* 12, 967–983. doi:10.1016/j.jclepro.2004.02.031.
- Mirata, M., Emtairah, T., 2005. Industrial symbiosis networks and the contribution to environmental innovation: The case of the Landskrona industrial symbiosis programme. *Journal of Cleaner Production* 13, 993–1002. doi:10.1016/j.jclepro.2004.12.010.
- Olayide, O.A., 2015. Industrial ecology, industrial symbiosis and eco-industrial parks in Africa: issues for sustainable development, in Deutz, P., Lyons, D.I., Bi, J. (Eds), *International Perspectives on Industrial Ecology*, Cheltenham, UK and Northampton, MA, USA: Edward Elgar, 30-45.

- Ollerton, J., 2006. "Biological Barter": Interactions of Specialization Compared across Different Mutualisms. pp. 411–435 in Waser, N.M., Ollerton, J. (Eds), *Plant-Pollinator Interactions: From Specialization to Generalization*. University of Chicago Press.
- Paquin, R.L., Busch, T., Tilleman, S.G., 2015. Creating Economic and Environmental Value through Industrial Symbiosis. *Long Range Planning* 48, 95–107. doi:10.1016/j.lrp.2013.11.002.
- Posch, A., 2010. Industrial Recycling Networks as Starting Points for Broader Sustainability-Oriented Cooperation? *Journal of Industrial Ecology* 14, 242–257. doi:10.1111/j.1530-9290.2010.00231.x.
- Reinhard, S., Lovell, C.A.K., Thijssen, G., 1999. Econometric Estimation of Technical and Environmental Efficiency: An Application to Dutch Dairy Farms. *American Journal of Agricultural Economics* 81, 44–60. doi:10.2307/1244449.
- Sakr, D., Baas, L., El-Haggar, S., Huisingh, D., 2011. Critical success and limiting factors for eco-industrial parks: global trends and Egyptian context. *Journal of Cleaner Production* 19, 1158–1169. doi:10.1016/j.jclepro.2011.01.001.
- Sokka, L., Lehtoranta, S., Nissinen, A., Melanen, M., 2011. Analyzing the Environmental Benefits of Industrial Symbiosis. *Journal of Industrial Ecology* 15, 137–155. doi:10.1111/j.1530-9290.2010.00276.x
- Sterr, T., Ott, T., 2004. The industrial region as a promising unit for eco-industrial development—reflections, practical experience and establishment of innovative instruments to support industrial ecology. *Journal of Cleaner Production* 12, 947–965. doi:10.1016/j.jclepro.2004.02.029.
- Tudor, T., Adam, E., Bates, M., 2007. Drivers and limitations for the successful development and functioning of EIPs (eco-industrial parks): A literature review. *Ecological Economics* 61, 199–207. doi:10.1016/j.ecolecon.2006.10.010.
- Van Berkel, R., Fujita, T., Hashimoto, S., Geng, Y., 2009. Industrial and urban symbiosis in Japan: Analysis of the Eco-Town program 1997–2006. *Journal of Environmental Management* 90, 1544–1556. doi:10.1016/j.jenvman.2008.11.010.
- White, R., 1994. Preface, in Allenby, B.R., Richards, D.J. (Eds), *The Greening of Industrial Ecosystems*. National Academy Press.
- Yazan, D. M., Romano, V.A., Albino, V., 2016. The design of industrial symbiosis: an input–output approach. *Journal of Cleaner Production* 129, 537–547.
- Zhang, Y., Zheng, H., Chen, B., Su, M., Liu, G., 2015. A review of industrial symbiosis research: theory and methodology. *Front. Earth Sci.* 9, 91–104. doi:10.1007/s11707-014-0445-8