



Politecnico
di Bari

Repository Istituzionale dei Prodotti della Ricerca del Politecnico di Bari

Design of a Microwave Sensor for Measurement of Water in Fuel Contamination

This is a pre-print of the following article

Original Citation:

Design of a Microwave Sensor for Measurement of Water in Fuel Contamination / Andria, G.; Attivissimo, F.; Di Nisio, A.; Trotta, A.; Camporeale, S. M.; Pappalardi, P.. - In: MEASUREMENT. - ISSN 0263-2241. - STAMPA. - 136:(2019), pp. 74-81. [10.1016/j.measurement.2018.12.076]

Availability:

This version is available at <http://hdl.handle.net/11589/160074> since: 2021-03-12

Published version

DOI:10.1016/j.measurement.2018.12.076

Publisher:

Terms of use:

(Article begins on next page)

Design of a Microwave Sensor for Measurement of Water in Fuel Contamination

G. Andria, F. Attivissimo, A. Di Nisio, A. Trotta
Dept. of Electric and Information Engineering
Polytechnic University of Bari
Bari, Italy

[gregorio.andria, filippo.attivissimo, attilio.dinisio,
amerigo.trotta]@poliba.it

S. M. Camporeale, P. Pappalardi
Dept. of Mechanics, Mathematics and Management
Polytechnic University of Bari
Bari, Italy

[sergio.camporeale, pietro.pappalardi]@poliba.it

Abstract— In this paper the modeling and the design of a microwave sensor is proposed for *real-time* fuel quality monitoring, with particular regard to water-in-fuel measurement.

A mechanical and fluid-dynamic dimensioning has been performed, evaluating the stiffness, the robustness of the sensor structure and the pressure field acting on it. Furthermore, an electromagnetic study is carried out to verify the validity of the physical measurement principle. The procedure adopted involves the modeling of the sensor in CAD and the simulation of its behavior. The sensor, based on microwave transmittance, is attractive because of its simplicity and foreseeable low cost.

Keywords—microwave measurements; fuel quality; water contamination; material characterization; coaxial transmission line; real-time monitoring; transmittance.

I. INTRODUCTION

The fuel system consists of tank, pump, filter and injectors or carburetor, and has the function of bringing fuel to the engine when necessary. Each component must work perfectly to ensure optimal performance and reliability. The fuel should lubricate precision components and cool metal surfaces that operate under friction conditions so that the engine operates reliably. Water is the worst contaminant that affects engine operation. Therefore, fuel control is part of maintenance operations to extend the life of the engine, optimizing performance, preventing breakdowns and reducing fuel consumption and harmful atmospheric emissions.

Their deterioration may be caused by the use of poor-quality fuel. Water is the main contaminant that affects the quality of fuel, both in the automotive field [1], [2] as well as in the field of aerospace [3], [4]. Water causes the reduction of lubricating properties, the reduction of engine power, the growth of microorganisms, influences the combustion process, the wear and corrosion of the power system, including feed pumps, filters, injectors and pipelines. In particular, in aircraft, ice

formation may occur on the supply filters which would lead to failure or collapse of the engine supply system [5], [6]. Water contamination can occur in different ways: during filling of the fuel tank; from vapor condensation; or from a source of contaminated fuel during the refueling process. In the automotive field, the EN 590 standard [7] prescribes the characteristics that fuel must have to be sold in the European Union and in many other European countries, while in the aerospace field, the specifications are indicated in the ASTM D1655 standard [8]. The maximum allowable water limit in the fuel is within a range of 200 to about 500 ppm for the automotive field while it is strictly 300 ppm for the aircraft field. Furthermore, the chemical-physical characteristics of fuel varies with the region of origin of the crude oil. Therefore, we must consider different limits in the rest of the world [9].

As prescribed by ISO 12937 [10], water concentration measurements in fuel are executed by the Karl Fischer titration. While for aircraft, ground control techniques are used, such as coalescence filter or water separation methods [11]. However, these techniques have the limitation of being performed in the laboratory and therefore cannot provide online monitoring.

In this work, which is based on preliminary results shown in [12], we illustrate the mechanical and electromagnetic design of a microwave sensor for detecting water contamination. It allows online monitoring of the attenuated transmission signal in a guiding structure, which will indicate the presence of a deviation from the value of the dielectric constant of the diesel, and therefore the presence of water that exceeds the limit imposed by the standards.

This paper is illustrated as follows: Sec. II is an overview of measurement techniques used to measure the dielectric constant of a medium; in Sec. III the principle of operation of the sensor is illustrated and its geometry defined; while in Sec. IV the mechanical, fluid-dynamic and electromagnetic modeling of the sensor is carried out, as well as its allocation.

II. REVIEW OF MEASUREMENT TECHNIQUES

Important requirements of the intended measurement system are that it should work in-line, during engine operation, be of small size and low cost. It may complement other on board diagnostic systems[13]-[16]. A great variety of measurement systems have been developed to ensure quality and reliability of aerospace components. [17]-[22].

There are two potential families of measurement methods which can be used for online fuel quality monitoring: optical techniques and microwave techniques. Other methods, based on capacitive and resistive sensors, are only able to detect water presence; in addition, corrosion of sensitive parts in contact with the fuel can occur, because it has a very aggressive chemical nature, which makes them unsuitable for in-line monitoring and poses difficulties to the use of electrochemical sensors.[23]-[28]

Optical measurements (e.g. spectrophotometry, fluorescence spectroscopy, etc.) present evident difficulties in the calibration of an extremely low detection threshold as the one required by previously described standards. However, the literature on water absorption spectra is very large [29]-[32]. In general, an optical system consists of a source and a detector which measures the absorption spectrum of the analyzed sample and extracts the information to be sent to the Engine Control Unit [34], [35].

On the other end, microwave techniques permit to measure an important parameter associated with electromagnetic propagation, namely the complex permittivity of the propagation medium [36]-[38]. In particular, Time Domain Reflectometry (TDR) is a technique based on the analysis of the signal traveling along a transmission line and reflected by a generic load [39]-[40].

The permittivity of the medium affects how the signal will be reflected, attenuated and transmitted between a source and a receiver. Many factors such as read-out rate, accuracy, convenience, and material shape and form are important in selecting the most appropriate measurement technique. The most used microwave measurement techniques are: open ended probe, transmission line, resonant cavity and free space, with applications that span radar, environmental monitoring and medical imaging [41]-[49]. These measurement techniques are different and each one has advantages and disadvantages compared to the others, moreover, it is often difficult to determine which method of measurement may perform better for a given material sample, because this choice depends on several factors, such as the nature of the dielectric material to be measured, the frequency of interest, and also the degree of precision required. Often, electromagnetic properties of media can be measured by means of waveguide transmission lines and coaxial lines [50]-[54].

The most prevalent type of transmission line is the coaxial transmission line. It consists of a cylindrical conductor concentric with a hollow external conductor where, as is the case of this paper, a liquid can circulate inside. It is therefore possible to monitor the behavior of the various interfaces present along the propagation path in order to locate the different discontinuities of the medium and measure the physical-chemical characteristics of the substances (dielectric constant, electrical conductivity, possible presence of emulsions, sediments, dispersions etc.). Coaxial transmission lines are compact in size, and present low loss and low dispersion, making them a suitable structure for the design of microwave circuits.

Generally, the calculation of the dielectric parameters is performed by measuring the S-parameters of the network under examination [55]. For the characterization of the contaminants, in the laboratory, a Vector Network Analyzer can be used to measure transmitted and reflected waves, from which the scattering parameters are subsequently processed to obtain complex permittivity [56]-[61]. The same principle of measuring the transmitted power is at the basis of the conception of the in-line sensor proposed in this work.

III. SENSOR CONCEPT

The sensor is designed for the automotive field, with the aim of monitoring the quality of the diesel in real time. It is foreseen to house the sensor in the pipes of the power supply system. The innovative aspect of this sensor is the ability to exploit the diesel as an element that flows inside the sensor itself and, during its passage, measure microwave attenuation. In this way, the presence of water can be detected and, if the system is appropriately sized, conditioned and calibrated, water content can be measured. A transmission measurement method has been chosen as it appears the simplest and most economic technique, because of the availability of very low-cost integrated circuits for the generation of the stimulus signal, and the use of a simple sensor with an envelope threshold detector for the measurement of the attenuated signal, which can be part of a small and low power embedded system [62]. The threshold detector may be useful, in particular, to provide an alert around a programmable level of the signal envelope. The most suitable guiding structure is certainly the coaxial one that guarantees the maximum fringing of the EM field in the analyte and, consequently, the maximum sensitivity.

Currently, the proposed methodology has been simulated with diesel fuel in the following conditions: a signal frequency range from 2 GHz to 8 GHz, the variation of the water concentration in the diesel according to the limits imposed by the EN590 standard and the variation of the radius of the core of the coaxial structure.

a. Preliminary geometry

Sensor geometry is shown in Fig.1. Preliminary sizing was defined by imposing a characteristic impedance Z_0 of the transmission line equal to 50Ω , using the following equation:

$$Z_0 = \frac{138}{\sqrt{\epsilon_r}} \log_{10} \frac{D}{d} \Omega \quad (1)$$

where ϵ_r is the relative dielectric constant of diesel equal to 2.1, D is the inner diameter of the shield equal to 4.5 mm and d is the diameter of the core. The diameter of the shield is imposed by the size of the power supply system piping. From this equation we have obtained an initial value of the core diameter, according to which we have designed spacers that support the core within the shield, as shown in Fig.1.

b. Selection of materials

The operating environment has specific characteristics such as temperature range, presence of vibrations, shocks and corrosive elements. These environmental and working aspects play an important role when choosing a material for this application. Hence one of the critical steps in the design process is the selection of materials. Materials must have good or excellent electrical, mechanical and environmental performance, particularly good electrical conductivity, machinability and ductility, good stability and tensile strength to withstand mechanical influences, good stress relieving, hardness and reasonable price [63],[64].

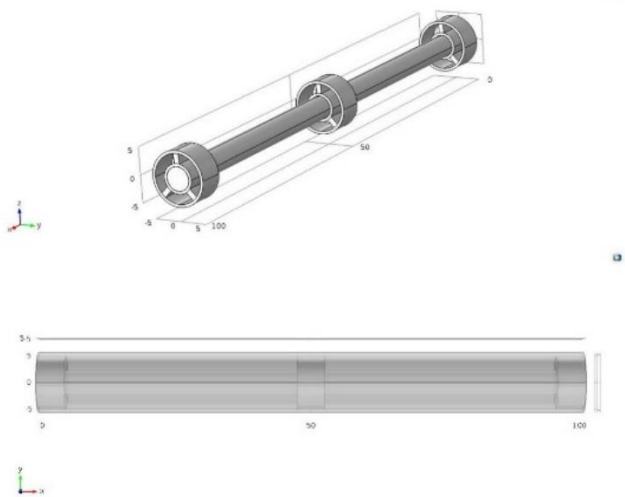

Fig. 1. Preliminary geometry of the coaxial structure. In the upper figure, shielding has been removed.

Regarding the conductive part of the guiding structure, common materials on the market are copper, stainless steel and aluminum. Copper is one of the most commonly used metals for conducting electrical signals and is preferred to stainless steel which is more difficult to process than the former. Copper

and aluminum offer good corrosion resistance and good breaking strength. The final choice, however, relies on copper, due to its versatility and its ability to be used in copper-copper welding without the use of a filler material.

To minimize the housing space and get an electric length such as to observe the attenuation of the signal, the axial length of the sensor has been fixed at 100 mm.

As for the spacers, they must guarantee good corrosion resistance, good mechanical resistance and minimum signal attenuation. As seen in the preliminary design, they will not have to occupy much free volume. The spacer will be stuck to the core and glued to the shield. The separation between core and shield is guaranteed by three equidistant fins and arranged in a polar way around the core to minimize the space occupied by the spacer, as shown in Fig. 2.

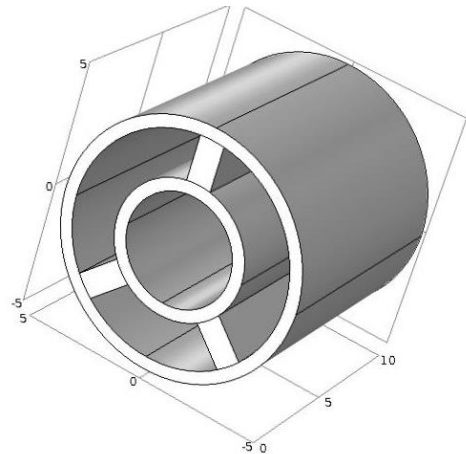

Fig.2. Spacer geometry.

The following materials are commercially available: polyethylene (PE), polytetrafluoroethylene (PTFE), PEEK (or polyether-ether-ketone), polyphenylene oxide (PPO) and silicone rubber. The final choice will be between PE and PTFE, because in addition to their good workability and discrete mechanical properties, they have a dielectric constant very similar to that of diesel. The latter is a necessary condition to avoid significantly disturbing the propagation of the stimulus signal.

IV. SIMULATION AND RESULTS

In this section we have modeled the sensor by studying the mechanical resistance, the stiffness, the fluid dynamic load and the electromagnetic validation of the physical measurement principle. The sensor must evaluate the attenuation of the signal, in terms of power, due to the different dielectric constant of the water with respect to the diesel. It was decided to evaluate the dielectric constant because it is an important indicator of the quality of diesel oil. When this differs from the standard value it can indicate the presence of contaminants, such as water.

a. Mechanical Design

In the multi-physics simulation, the sensor was modeled considering the core suspended in the shield, thanks to three spacers, two at the ends and one at the centerline. The spacers were constrained at the spacer-core and spacer-shield interfaces while the shield was externally constrained. The acting loads are the weight of the same physical structure and the fluid dynamic load of the diesel fuel flow, in terms of pressure. The simulations were conducted by comparing the materials listed in the previous section and it was verified that under static conditions, the maximum deflection that the core undergoes is negligible, of the order of nanometers, as shown in the Fig.3. In the same way, the velocity profile that is generated inside the structure does not cause excessive local pressure peaks, particularly in the areas of connection between spacers and cores. Also, in this case the deformations of the spacers have orders of the nanometers, as shown in Fig.4. When varying the radius among feasible values, we obtained, in general, increasing deflections of the core that remain, however, of the same order of magnitude, as shown in Table 1.

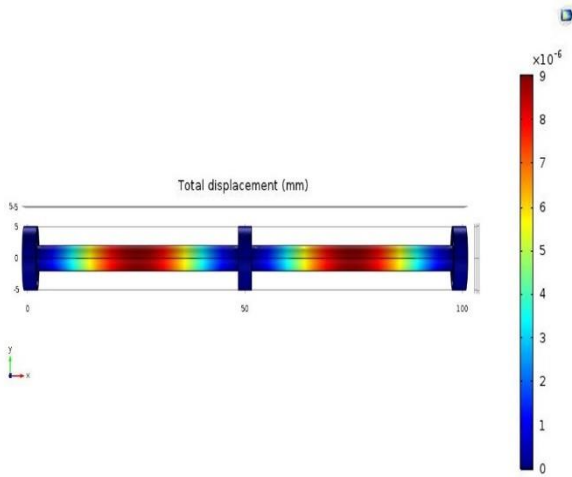

Fig.3. Displacement field of the core.

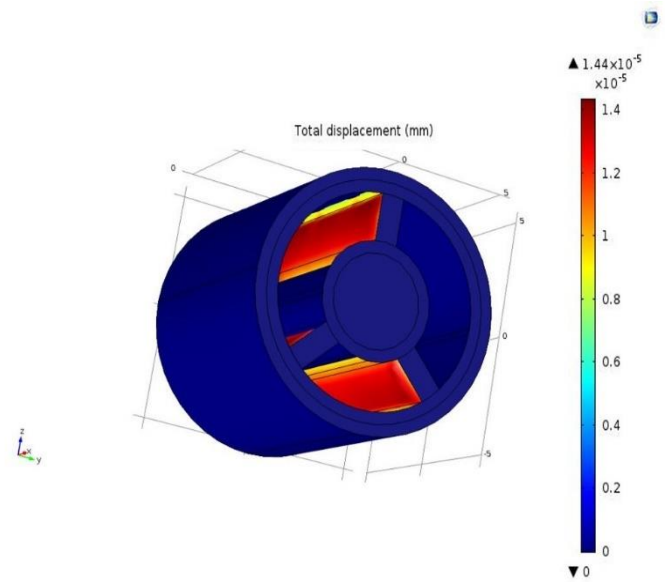

Fig.4. Displacement field of the spacer.

RADIUS OF CORE (mm)	MAXIMUM CORE DEFORMATION (nm)
1.00	0.79
1.35	1.35
1.70	1.92
2.05	2.29
2.40	2.43
2.75	2.28
3.10	1.90
3.45	2.33
3.80	2.82
4.15	3.36
4.50	3.94

Tab. 1. Maximum core deformation depending on its radius.

After comparing the static strength of the critical elements of the guiding structure, core and spacer, we have identified in the copper and polyethylene, respectively, the materials suitable for the development of the sensor, as shown in Table 2 and 3. For the materials compared, the maximum deflection arrow of the core is always very low. Copper is also chosen because of its greater electrical conductivity and the lower price. The same considerations apply to spacers. The thinning of the material, the dielectric constant and the price are evaluated. Polyethylene is the best choice.

	COPPER	ALUMINUM	STAINLESS STEEL
POISSON COEFFICIENT	0.34	0.35	0.27
DENSITY [kg/m ³]	8960	2700	8000
YOUNG MODULE [MPa]	120000	70000	200000
ELECTRIC CONDUCTIBILITY [S/m]	59.6*10 ⁶	37.7*10 ⁶	1.45*10 ⁶
PRICE	LOW	HIGH	HIGH

MAXIMUM DEFLECTION OF THE CORE [nm]	86.6	44.7	46.5
-------------------------------------	------	------	------

Tab. 2. Comparison of materials for the core.

	PE	PTFE	PEEK	PPO	SILICONE RUBBER
POISSON COEFFICIENT	0.42	0.45	0.38	0.38	0.48
DENSITY [kg/m ³]	930	2200	1320	1060	1100
YOUNG MODULE [MPa]	1000	400	360	250	50
DIELECTRIC CONSTANT	2.3	2.1	3.3	2.7	2.9-4
PRICE	LOW	VERY HIGH	VERY HIGH	HIGH	LOW
MAXIMUM THINNING OF THE SPACER [nm]	0.04*10 ⁻²	0.11	938	0.17	0.79

Tab. 3. Comparison of materials for the spacer.

b. Electromagnetic Design

Subsequently, the electromagnetic analysis of the sensor has been refined. In Fig.5 it is highlighted that the structural characteristics of the system under test invite decidedly to use coaxial structures, since they ensure the maximum fringing field EM near the core and, consequently, the maximum sensitivity. The electromagnetic simulation was conducted by fixing a power to the input port equal to 1 W.

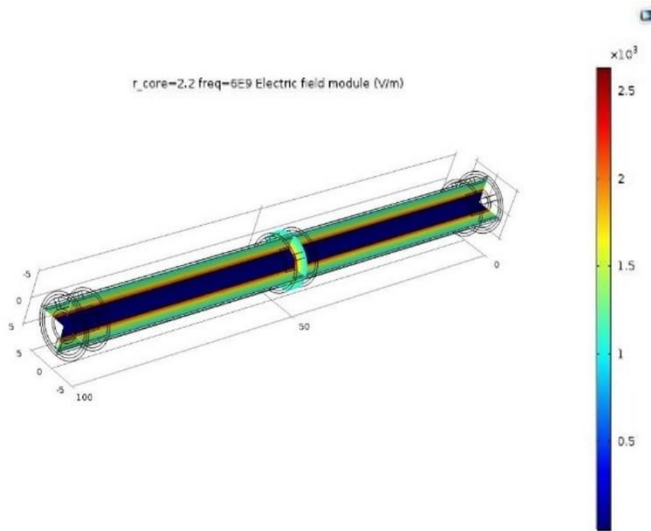

Fig. 5. Module of the electric field in the coaxial structure with pure diesel dielectric, at $f = 6$ GHz.

Simulations were performed by using COMSOL Multiphysics software in order to find the relation between critical sensor

parameters and sensitivity. For the preliminary simulations, it was decided to adopt a very simple mathematical model to express the relative dielectric constant of the analyte as a function of the water concentration:

$$\epsilon_{eff} = (\epsilon_W - \epsilon_D)\rho + \epsilon_D \quad (2)$$

where $\epsilon_D = 2.1$ is the relative dielectric constant of pure diesel, $\epsilon_W = 80.4$ is the relative dielectric constant of water and ρ is the concentration of water in the analyte. Unfortunately, there are not many data on $\tan \delta$ which, therefore, has been neglected to the first approximation. This approximation should not invalidate the simulations given that, in practice, extremely small water concentrations will be measured which affect negligibly $\tan \delta$. It is expected, in any case, that $\tan \delta$ grows with ρ , therefore, the sensitivity of the system should at least improve taking into account dielectric losses.

Multiparametric simulations were performed, essentially by varying three parameters: the frequency of the stimulus signal, f , the thickness of the core, r_i , and the concentration of water in the fuel, ρ . The first two are operational parameters, while concentration is the independent variable of the problem under analysis. The geometric constraints are the diameter of the shield, dimensionally equivalent to the conduct in which the sensor will be housed, of about 5 mm and the length of the coaxial transmission, of 100 mm. Fig. 6 shows the results of the simulations performed at $f = 6$ GHz, for different values of the radius of the core r_i . From these results, it is clear that attenuation increases for larger radii.

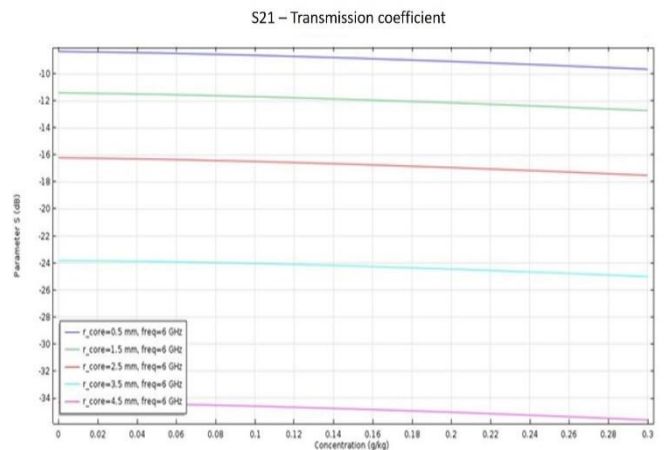

Fig. 6. Transmission coefficient for different values of core radius r_i .

Moreover, we have verified that with the increase of the frequency of the stimulus signal, with the same radius, sensitivity increases, hence sensor detectivity may be tuned. This can be useful because, although the standards set a maximum limit of water, this limit will vary according to the geographical area of origin of the diesel, as shown in Fig.7.

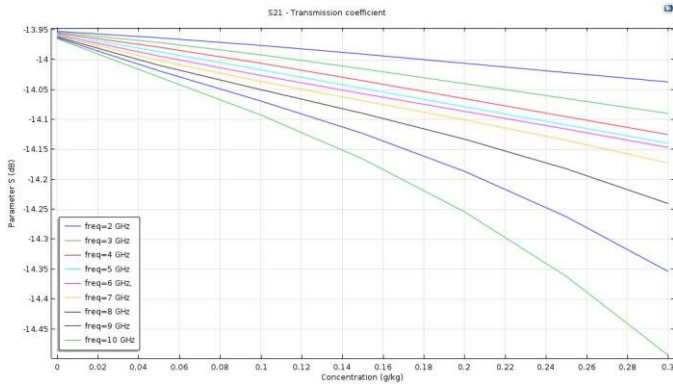

Fig. 7. Transmission coefficient for different values of frequency of the stimulus signal.

Considering both the electromagnetic modeling and the fluid-dynamic modeling, we conclude that a small core radius is advantageous. This choice is strengthened by the fact that the size of the core determines the weight and bulk of the line. Obviously to minimize the weight and mass of the coaxial transmission line and decrease attenuation, we should reduce the radius as much as possible. However, there are lower limits on core radius as regards manufacturability, power carrying capabilities, and safety. Indeed, for lower radii the electromagnetic field increases within the coaxial line, which can lead to breakdown of the dielectric due to ionization, a dangerous condition. For these reasons, we have chosen, for the dimension of the core, a radius equal to 2.2 mm, which gives a maximum field of about 3 kV/m.

With that value, high fringing on the core and good sensitivity are achieved, as shown in the Fig.7. In the graph, the linearity of the transmission coefficient is appreciated up to the maximum permissible concentration of water in diesel according to standards, i.e. not exceeding 0.25 g/kg, namely 250 ppm, as required by the standards. Mechanically, the stiffness of the structure is guaranteed by the arrangement and the geometry of the spacers that, thanks to the core size, occupy only a small portion of space between shield and core.

For in-line integration, the sensor needs stimulus, conditioning and read-out devices to be installed directly on it. The maximum sensitivity configuration shows an excellent linearity of the transmission coefficient with respect to the water concentration in ppm, with sensitivity:

$$\frac{\Delta S_{21}}{\Delta \rho} = 0.6 \frac{\text{mdB}}{\text{ppm}} \quad (3)$$

A $\Delta \rho$ of 50 ppm produces a variation of S_{21} equal to 0.03 dB, which is appreciable if the sensor is appropriately conditioned and calibrated.

V. SENSOR ALLOCATION

For the design of the connection geometry of the coaxial system to the fuel piping and to a printed circuit board there are several methods such as soldering, crimping or a separable connection method (e.g. press fit attachment). Two solutions have been foresaw. The first involves the construction of two holes in the shield, respectively at the two ends of the core (Fig. 8). The entrance to the fuel stream is provided from a hole, while in the second one is the exit. The second solution involves the flexion of the conducting core at its ends. In the latter case, the ends of the core will be guided externally via two T-connectors, while fuel enters the sensor trough an opening along its axis.

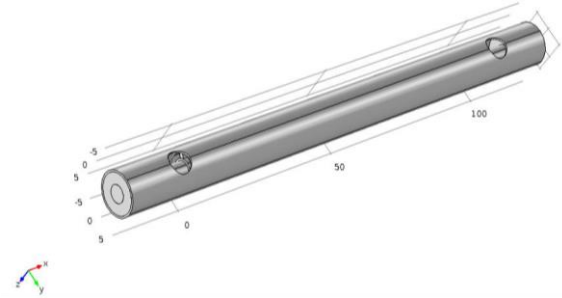

Fig. 8. Coaxial Connector Design: Hole-drilling.

We choose the first solution, i.e. to divert the flow rather than the electromagnetic waves, because otherwise the behavior of the new bended core geometry could affect the extent of the attenuation. Also, the bending processing to be applied to the core could affect the stiffness of the guiding structure.

Through fluid-dynamic simulations based on the Arbitrary Lagrangian Eulerian (ALE) we verified that the pressure drops losses that the sensor produces inside a pipe with a typical diesel flow rate is about 1500 Pa. Figure 9, 10 and 11 show the pressure upstream and downstream of the sensor housing, the velocity field and the maximum deflection occurring on the core. Deflection is negligible, in the order of magnitude of nanometers. The new configuration maintains a very low deflection of the core, of about 6,07 nm.

In the inlet section of the flow, the maximum pressure is 90000 Pa while in the outlet section is about 80900 Pa, with a pressure loss of a little over 9000 Pa.

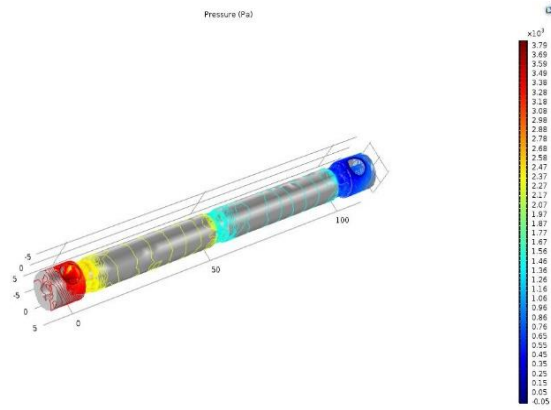

Fig.9. Pressure acting on the sensor connect to the fuel pipe.

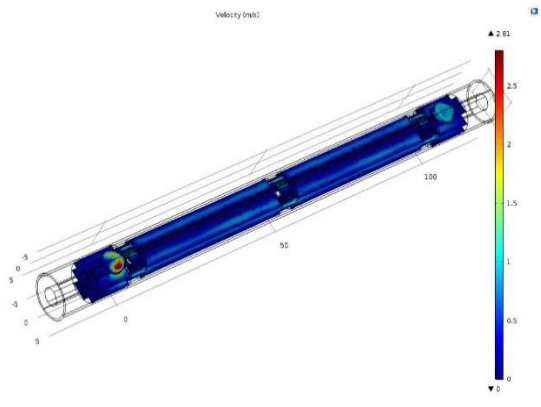

Fig.10. Velocity field inside the sensor connect to the fuel pipe.

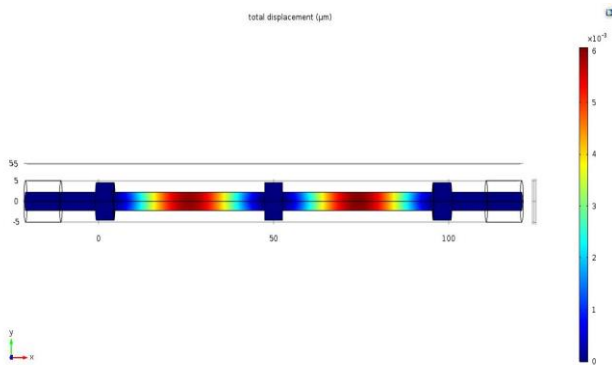

Fig.11. Displacement field inside the sensor connect to the fuel pipe.

Finally, we improved the sensor connection to the diesel fuel system through two sleeves. The sleeves may be welded to the pipe of the supply system, equipped with additional holes. In particular, it is obtained that if flaps, suitably oriented, are used, there is a flow entering the sensor at a lower speed and therefore the stress, which the flow can generate to the core in its input, is reduced, while at the output, a flap oriented in the opposite direction, minimizes pressure drop losses caused by the

presence of the sensor opening. The losses considered in the design take into account both the losses distributed along the sensor as well as the ones concentrated on inlets, edges and variations in the flow passage section. Through the simulations, we estimate that in the improved design these losses are at a level of about 1000 Pa, which is considered acceptable. Full details of the velocity field and pressure field generated by the presence of the guide vanes are shown in Figs. 12 and 13.

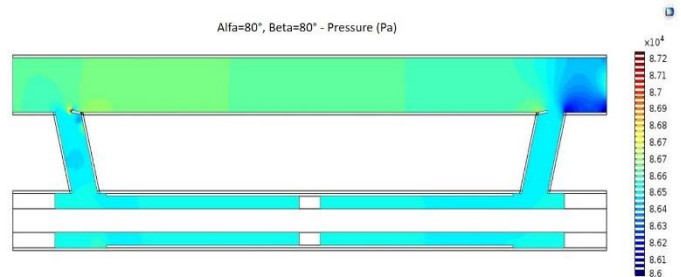

Fig.12. Pressure field in the final configuration.

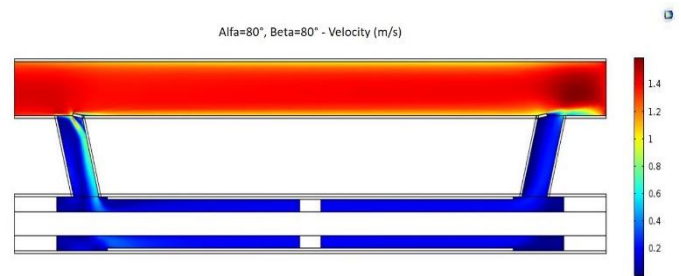

Fig.13. Velocity field in the final configuration.

VI. CONCLUSION

Fuel characteristics are important to ensure that the engine operates reliably; so, a sensor able to monitor fuel in real-time and to detect anomalies in the fuel is proposed. The sensor is based on transmission at microwave frequencies inside a coaxial transmission line appropriately sized.

In this paper a study to optimize the geometry of sensor is carried out in order to verify the rigidity and strength of the guiding structure and the corrosion resistance of the system. This is achieved by choosing copper and polyethylene, respectively for the core and spacers. The material of the core has excellent electrical conductivity and good mechanical strength. The material of the spacers avoid signal reflection and permits to support the core in the shield, minimizing the core deflection and taking up less volume with a suitable geometry.

It has been verified by simulations that introducing into the sensor fuel with a different water contents, i.e. a different permittivity, microwave attenuation changes with a sensitivity of 0.6 mdB/ppm at 6 GHz.

The results show that the sensitivity increases with frequency, while core size is a compromise between electromagnetic performance and manufacturability. Tuning of sensitivity may be useful in order to work in different geographical area, since the chemical nature of the fuel changes with respect to production place.

Future developments will concern the design of the electronics and manufacturing of the sensor and the test of diesel specimens with emulsified water.

VII. ACKNOWLEDGMENT

We acknowledge Bosch - Centro Studi Componenti per Veicoli S.p.A., Bari, Italy for the support provided in defining sensor requirements and having provided fuel samples.

REFERENCES

- [1] J.C. Scheider, "Fuel Composition and Quality Sensing for Diesel Engines", Thesis for the Degree of Master of Science in Mechanical Engineering in the Graduate College of the University of Illinois at Urbana-Champaign, 2011.
- [2] C. Duca, "Fuel Quality Sensors for HD Engines", Master of Science Thesis, Industrial Engineering and Management Machine Design, 2014.
- [3] S. Baena, S. L. Repetto, C.P. Lawson, J. K.-W. Lam, "Behaviour of Water in Jet Fuel A Literature Review", *Progress in Aerospace Sciences*, vol. 60, pp. 35-44, 2013.
- [4] J. A. Krynskiy, J. Crellin, H. Carhart, *The Behavior of Water in Jet Fuels and the Clogging of Micronic Filters at Low Temperatures*, Technical Report, Naval Research Lab Washington DC, 1950.
- [5] B. J. Murray, S. L. Broadley, G. J. Morris, *Supercooling of Water Droplets in Jet Aviation Fuels-Fuel*, vol. 90, pp.433-435, 2011.
- [6] Report on the accident to Boeing 777-236ER, G-YMMM, at London Heathrow Airport on 17 January 2008, Technical Report, Air Accident Investigation Branch, Department of Transport (UK), 2010.
- [7] "EN 590:2004 - automotive fuels. diesel. requirements and test methods," standard, European Committee for Standardization, Aug. 2004.
- [8] "ASTM D1655, Standard Specification for Aviation Turbine Fuels, Annual Book of ASTM Standards (Section 05), Technical Report", American Society of Testing and Materials (ASTM), 2009.
- [9] Fuel regulation: <http://www.diesalnet.com/standards>
- [10] "ISO 12937:2000 - petroleum products- determination of water - coulometric karl fischer titration method," standard, International Organization for Standardization, Nov. 2000.
- [11] "JIG 1:2008 - Guidelines For Aviation Fuel Quality Control & Operating Procedures For Joint Into-plane Fuelling Services", Technical Report, Joint Inspection Group Ltd., 2008.
- [12] G. Andria, F. Attivissimo, A. Di Nisio, G.M. D'Aucelli, S.M. Camporeale, P. Pappalardi, "Design of a Microwave Sensor for Fuel Quality Monitoring," in *Proc. 5th IEEE International Workshop on Metrology for AeroSpace, MetroAeroSpace, Rome, Italy*, pp. 608-612, June 20-22, 2018.
- [13] M. Ambrož, "Raspberry Pi as a low-cost data acquisition system for human powered vehicles," *Measurement*, vol. 100, 2017, pp. 7-18.
- [14] González A, Olazagoitia JL, Vinolas J., "A Low-Cost Data Acquisition System for Automobile Dynamics Applications," *Sensors*, 2018, vol. 18, no. 2, art. no. 366, pp. 1-20
- [15] Liuhanzi Yang, Shaojun Zhang, Ye Wu, Qizheng Chen, Tianlin Niu, Xu Huang, Shida Zhang, Liangjun Zhang, Yu Zhou, Jiming Hao, "Evaluating real-world CO₂ and NO_x emissions for public transit buses using a remote wireless on-board diagnostic (OBD) approach," *Environmental Pollution*, vol. 218, 2016, pp. 453-462.
- [16] G. Andria, F. Attivissimo, A. Di Nisio, A.M.L. Lanzolla, A. Pellegrino, "Development of an automotive data acquisition platform for analysis of driving behavior," *Measurement*, vol. 93, 2016, pp. 278-287.
- [17] J.-C. Mare, "Dynamic loading systems for ground testing of high speed aerospace actuators", *Aircraft Engineering and Aerospace Technology*, vol. 78, no. 4, pp.275-282, 2006.
- [18] D. M. Filatov, A. I. Friedrich and A. V. Devyatkin, "Parameters identification of thrust generation subsystem for small unmanned aerial vehicles," *2017 IEEE II International Conference on Control in Technical Systems (CTS)*, St. Petersburg, 2017, pp. 381-383.
- [19] M. Caciotta et al., "A first study on prognostic system for electric engines based on Envelope Analysis," *2014 IEEE Metrology for Aerospace (MetroAeroSpace)*, Benevento, 2014, pp. 362-366.
- [20] G. De Angelis, E. Dati, M. Bernabei and F. Leccese, "Development on aerospace composite structures investigation using thermography and shearography in comparison to traditional NDT methods," *2015 IEEE Metrology for Aerospace (MetroAeroSpace)*, Benevento, 2015, pp. 49-55.
- [21] F. Adamo, G. Andria, A. Di Nisio, C.G. Calò Carducci, A. Lay-Ekuakille, G. Mattencini, M. Spadavecchia, "Designing and prototyping a sensors head for test and certification of UAV components," in *International Journal on Smart Sensing and Intelligent Systems*, Massey University, vol. 10, no. 3, pp. 646-672, Sept 2017.
- [22] F. Adamo, G. Andria, A. Di Nisio, C. G. C. Carducci, A. M. L. Lanzolla and G. Mattencini, "Development and characterization of a measurement instrumentation system for UAV components testing," *2017 IEEE International Workshop on Metrology for AeroSpace (MetroAeroSpace)*, Padua, 2017, pp. 355-359.
- [23] K. Loizou, E. Koutroulis, "Water Level Sensing: State of the Art Review and Performance Evaluation of a low-cost Measurement System", *Measurement*, vol. 89, pp. 204-214, 2016.
- [24] S.F.A. Rahman, M. Ismail, N.M.D. Noor, H. Bakhtiar, "Embedded Capacitor Sensor For Monitoring Corrosion Of Reinforcement In Concrete", *Journal of Engineering Science and Technology*, vol. 7, pp. 209-218, 2012.
- [25] K. Loizou, E. Koutroulis, D. Zalikas, G. Lontas, "A Low-Cost Capacitive Sensor for Water Level Monitoring in large-scale Storage Tanks", *Industrial Technology (ICIT)*, pp. 1416-1421, 2015.
- [26] A. Agoston, C. Ötsch, B. Jakoby, "Viscosity sensors for engine oil condition monitoring—Application and interpretation of results," *Sensors and Actuators A: Physical*, vol. 121, no. 2, 2005, pp. 327-332.
- [27] S.G. Leonardi, M. Bonyani, K. Ghosh, A.K. Dhara, L. Lombardo, N. Donato, G. Neri, "Development of a Novel Cu(II) Complex Modified Electrode and a Portable Electrochemical Analyzer for the Determination of Dissolved Oxygen (DO) in Water", *Chemosensors*, vol. 4, no. 2, 2016
- [28] C. Casavola, P. Pappalardi, G. Pappaletta, G. Renna, "A Fringe Projection Based Approach for Corrosion Monitoring in Metals", *Experimental Techniques*, vol. 42, pp. 1-7, 2018.
- [29] T. I. Quickenden and J. A. Irvin, "The ultraviolet absorption spectrum of liquid water," *The Journal of Chemical Physics*, vol. 72, no. 8, pp. 4416-4428, 1980.
- [30] Z. Fan, O. Schroder, and J. Krahl, "Analysis of diesel fuels/biodiesel blends and identification of biodiesel using time-resolved laser-induced fluorescence spectroscopy (TRLFS)," *Appl Agric Forestry Res*, vol. 65, pp. 1-14, 2015.
- [31] T. I. Quickenden and J. A. Irvin, "The ultraviolet absorption spectrum of liquid water," *The Journal of Chemical Physics*, vol. 72, pp. 4416-4428, Apr. 1980.
- [32] E. Arik, H. Altan, and O. Esenturk, "Dielectric Properties of Diesel and Gasoline by Terahertz Spectroscopy," *Journal of Infrared, Millimeter and Terahertz Waves*, vol. 35, pp. 759-769, Sept. 2014.
- [33] F. Attivissimo, C. G. C. Carducci, A. M. L. Lanzolla, A. Massaro and M. R. Vadrucchi, "A Portable Optical Sensor for Sea Quality Monitoring," in *IEEE Sensors Journal*, vol. 15, no. 1, pp. 146-153, Jan. 2015.
- [34] J. A. Curcio and C. C. Petty, "The Near Infrared Absorption Spectrum of Liquid Water," *JOSA*, vol. 41, pp. 302-304, May 1951.
- [35] M. R. Anderson, "Determination of Infrared Optical Constants for Single Component Hydrocarbon Fuels," p. 185.

- [36] C. Diniz Carvalho, A. K. Barros, M. V. Lopes, F. C. Silva, E. E. Santana, and F. S. M. Sinfrônio, "Determination of the composition of biodiesel-diesel blends using the dielectric constant," *Instrumentation Science & Technology*, vol. 44, pp. 377-385, July 2016.
- [37] N. Ahmadian, S. Hasan, and O. P. N. Calla, "Permittivity and Backscattering Coefficient of Diesel Oil- Contaminated Soil at C Band (5.3 GHz)," *International Journal of Microwave Science and Technology*, vol. 2013, pp. 1-9, 2013.
- [38] A. D. Sen, V. G. Anicich, and T. Arakelian, "Dielectric constant of liquid alkanes and hydrocarbon mixtures," *Journal of Physics D: Applied Physics*, vol. 25, pp. 516-521, Mar. 1992.
- [39] Daniel B. R. Rodrigues, Henrique E. M. Peres, Wesley Becari, "Ethanol Fuel Analysis By Time-Domain Reflectometry", *Microwave & Optoelectronics Conference*, 2013.
- [40] A. Cataldo, L. Tarricone, M. Vallone, F. Attivissimo and A. Trotta, "Uncertainty Estimation in Simultaneous Measurements of Levels and Permittivities of Liquids Using TDR Technique," in *IEEE Transactions on Instrumentation and Measurement*, vol. 57, no. 3, pp. 454-466, March 2008.
- [41] G. Ruvio, M. Vaselli, V. Lopresto, R. Pinto, L. Farina, and M. Cavagnaro, "Comparison of different methods for dielectric properties measurements in liquid sample media," *International Journal of RF and Microwave Computer-Aided Engineering*, vol. 28, p. e21215, Mar. 2018.
- [42] M.S. Venkatesh and G.S.V. Raghavan, "An overview of dielectric properties measuring techniques", *Canadian Biosystems Engineering*, vol. 47, pp.15-30, 2005.
- [43] Sergio L. S. Severo, Álvaro A. A. de Salles, "Non-resonant Permittivity Measurement Methods", *Journal of Microwaves, Optoelectronics and Electromagnetic Applications*, vol. 16, no. 1, pp. 297-311, March 2017.
- [44] M. Klemm, J. A. Leendertz, D. Gibbins, I. J. Craddock, A. Preece and R. Benjamin, "Microwave Radar-Based Breast Cancer Detection: Imaging in Inhomogeneous Breast Phantoms," in *IEEE Antennas and Wireless Propagation Letters*, vol. 8, pp. 1349-1352, 2009.
- [45] E- G. Njoku, D- Entekhabi, "Passive microwave remote sensing of soil moisture," *Journal of Hydrology*, vol. 184, np. 1-2, 1996, pp. 101-129.
- [46] F. Adamo, G. Andria, O. Bottiglieri, F. Cotecchia, A. Di Nisio, D. Miccoli, F. Sollecito, M. Spadavecchia, F. Todaro, A. Trotta, C. Vitone, "GeoLab, a measurement system for the geotechnical characterization of polluted submarine sediments," *Measurement*, vol. 127, 2018, pp. 335-347. ISSN 0263-2241.
- [47] L. K. Yee, N. W. Hau, C. B. Kuan, P. Y. Nan, L. H. Sheng and L. E. Hock, "Modelling of microwave elliptical and conical tip sensors for in vivo dielectric measurements," 2015 *IEEE International RF and Microwave Conference (RFM)*, Kuching, 2015, pp. 222-226.
- [48] G. Andria, F. Attivissimo, A. Di Nisio, A.M. Lanzolla, A. Maiorana, M. Mangiantini, M. Spadavecchia, "Dosimetric Characterization and Image Quality Assessment in Breast Tomosynthesis," in *IEEE Transactions on Instrumentation and Measurement*, vol. 66, no. 10, pp. 2535-2544, Oct. 2017.
- [49] G. Andria, F. Attivissimo, G. Guglielmi, A.M.L. Lanzolla, A. Maiorana, M. Mangiantini, "Towards patient dose optimization in digital radiography," *Measurement*, vol. 79, 2016, pp. 331-338.
- [50] A. P. Gregory and R. N. Clarke, "Dielectric metrology with coaxial sensors," *Measurement Science and Technology*, vol. 18, pp. 1372-1386, May 2007.
- [51] A. Cataldo, E. De Benedetto, G. Cannazza, A. Masciullo, N. Giaquinto, G.M. D'Aucelli, N. Costantino, A. De Leo, M. Miraglia, "Recent advances in the TDR-based leak detection system for pipeline inspection," *Measurement*, vol. 98, 2017, pp. 347-354.
- [52] J. Choi, F. Iza, H. J. Do, J. K. Lee and M. H. Cho, "Microwave-excited atmospheric-pressure microplasmas based on a coaxial transmission line resonator", *IOP Publishing, Plasma Sources Sci. Technol. Vol. 18*, pp. 1-8, 2009.
- [53] S. Ahmad, M. Charles, D. Allal, P.S. Negi, V.N Ojha. "Realization of 2.4mm coaxial microcalorimeter system as national standard of microwave power from 1 MHz to 50 GHz", *Measurement*, vol. 116, pp. 106-113, 2018.
- [54] A. Cataldo, E. De Benedetto, G. Cannazza, E. Piuze, N. Giaquinto, "Embedded TDR wire-like sensing elements for monitoring applications," *Measurement*, vol. 68, 2015, pp. 236-245.
- [55] M. Feulner, G. Hagen, A. Müller, D. Brüggemann, and R. Moos, "In-Operation Monitoring of the Soot Load of Diesel Particulate Filters with a Microwave Method," p. 4, 2012.
- [56] X. Hao, L. Weijun, and G. Qiulai, "A New Dual-Channel Measurement Method for Accurate Characterization of Low-Permittivity and Low-Loss Materials," *IEEE Transactions on Instrumentation and Measurement*, pp. 1-10, 2018.
- [57] A. Phungasem, K. Nuanyai, N. Puangngernmak, and S. Chalermwisutkul, "Implementation of a mobile device for complex permittivity measurement of liquids based on microwave resonant method," pp. 412-416, *IEEE, July 2014*.
- [58] J. Obrzut, "General analysis of microwave network scattering parameters for characterization of thin film materials", pp. 2963-2970, *Measurement* 46, 2013.
- [59] A. Aboutaleb, G. Chi-Tangyie, K. Huddersman, C. H Oxley, "Microwave dielectric measurements of fibrous catalyst using transmission line technique in the frequency range of 1-4 GHz", pp. 2671-2676, *MICROWAVE AND OPTICAL TECHNOLOGY LETTERS* 56, 2014.
- [60] R. M Ismail, H. M Al-Mattarneh, M. Fadhil Nuruddin, N. Shafiq, M. A Dahim, "Dielectric Dispersion Characteristics of Unsaturated Sand Contaminated by Diesel", pp. 1-6, *Journal of Material Sciences & Engineering*, 2017.
- [61] S. Zeng, A. Trontz, W. Zhu, H. Xiao, J. Dong, "A metal-ceramic coaxial cable Fabry-Pérot microwave interferometer for monitoring fluid dielectric constant", *Sensors and Actuators A* 257, pp. 1-7, 2017.
- [62] A. Di Nisio, T. Di Noia, C. G. C. Carducci and M. Spadavecchia, "High Dynamic Range Power Consumption Measurement in Microcontroller-Based Applications," in *IEEE Transactions on Instrumentation and Measurement*, vol. 65, no. 9, pp. 1968-1976, Sept. 2016.
- [63] HUBBER+SUHNER, "RF CONNECTOR GUIDE, Understanding connector technology", 2007.
- [64] M.F. Ashby, "MATERIALS SELECTION IN MECHANICAL DESIGN", *Butterworth-Heinemann*, 1999.