



Politecnico di Bari

Repository Istituzionale dei Prodotti della Ricerca del Politecnico di Bari

The implementation of automatic diagnostics and monitoring towards Diagnosis-Aided Historic Building Information Modelling and Management

This is a PhD Thesis

Original Citation:

The implementation of automatic diagnostics and monitoring towards Diagnosis-Aided Historic Building Information Modelling and Management / Bruno, Silvana. - ELETTRONICO. - (2019). [10.60576/poliba/iris/bruno-silvana_phd2019]

Availability:

This version is available at <http://hdl.handle.net/11589/161087> since: 2019-01-18

Published version

DOI:10.60576/poliba/iris/bruno-silvana_phd2019

Publisher: Politecnico di Bari

Terms of use:

(Article begins on next page)



D.R.R.S.

POLITECNICO DI BARI

01

Doctor of Philosophy in Risk and Environmental, Territorial and Building Development

2018

Coordinator: Prof. Michele Mossa

XXXI CYCLE ICAR/10 – ICAR/11
Built Environment - Building Production

DICATECh
Department of Civil, Environmental, Land,
Building Engineering and Chemistry

The implementation of automatic diagnostics and monitoring towards Diagnosis-Aided Historic Building Information Modelling and Management

Supervisors:

Prof. Fabio Fatiguso
DICATECh - Polytechnic University of Bari, Italy

Prof. Guido Raffaele Dell’Osso
DICATECh - Polytechnic University of Bari, Italy

Prof. Lamine Mahdjoubi
FET - University of West England, Bristol, UK

PhD Candidate:
Silvana Bruno

INDEX

| | |
|--|----|
| EXTENDED ABSTRACT (eng) | 4 |
| EXTENDED ABSTRACT (ita) | 8 |
| INTRODUCTION..... | 13 |
| 1 INNOVATIVE APPROACHES IN REFURBISHMENT..... | 16 |
| 1.1 The role of incremental knowledge in refurbishment..... | 16 |
| 1.1.1 Risks in erroneous diagnosis of building pathologies and damages..... | 18 |
| 1.1.2 Methods of investigation..... | 19 |
| 1.2 Innovative management of integrated data and information..... | 20 |
| 1.2.1 The contribute of Building Information Modelling..... | 20 |
| 1.2.2 Premises and definitions..... | 22 |
| 1.2.3 Standards and guidelines for HBIM implementation..... | 25 |
| 2 STATE OF THE ART | 31 |
| 2.1 Literature review methodology | 31 |
| 2.2 Data collection and bibliometric approach about HBIM..... | 34 |
| 2.3 Critical analysis | 38 |
| 2.3.1 Information management and exchange tasks | 38 |
| 2.3.2 Information classification and representation | 39 |
| 2.3.3 Information management standards and protocols..... | 40 |
| 2.3.4 BIM services for knowledge sharing and reuse | 41 |
| 2.4 HBIM model, diagnosis and performance assessment..... | 43 |
| 2.4.1 Geometric survey, augmented visual inspection and parametric models..... | 43 |
| 2.4.2 The implementation of diagnostics and monitoring data in BIM | 52 |
| 2.5 Gaps in knowledge and future developments in HBIM for performance assessment | |
| 66 | |
| 2.5.1 Open issues..... | 66 |
| 3 A METHODOLOGICAL APPROACH FOR IMPLEMENTING PERFORMANCE ASSESSMENT IN HBIM FOR HISTORICAL ASSETS (DA-HBIMM)..... | 73 |
| 3.1 Toward Diagnosis-aided Historic Building Information Modelling..... | 73 |

| | | |
|-------|--|-----|
| 3.2 | Guidelines for knowledge structuration and work organization [OKS] | 80 |
| 3.3 | Surveying as-is/as-damaged conditions [RE] | 81 |
| 3.3.1 | Data capture and augmented visual inspections | 81 |
| 3.4 | Parametric modelling [Scan2BIM] | 82 |
| 3.4.1 | From point cloud/mesh to HBIM model..... | 82 |
| 3.5 | Semantic enrichment [PA] | 85 |
| 3.5.1 | Decay mapping in HBIM..... | 85 |
| 3.5.2 | Information requirements and Level of Information in refurbishment | 86 |
| 3.5.3 | Analysis and management of diagnostic tests and results | 88 |
| 3.5.4 | Analysis and management of monitored building performance | 90 |
| 3.6 | Automated diagnosis via DA-HBIMM [MDA] | 92 |
| 3.6.1 | Image processing for automated decay mapping | 92 |
| 3.6.2 | Inferential logic in the diagnosis of building decay..... | 97 |
| 3.6.3 | Degree of uncertainty | 101 |
| 4 | TESTING THE DA-HBIMM APPROACH..... | 106 |
| 4.1 | Overview of case studies..... | 106 |
| 4.2 | Knowledge structuration and HBIM project execution process map | 110 |
| 4.3 | Data acquisition and parametric modelling..... | 115 |
| 4.4 | Testing the degree of automation in parametric modelling | 123 |
| 4.5 | Semantic enrichment | 130 |
| 4.5.1 | Modelling and management of decay patterns | 130 |
| 4.5.2 | Image processing for automated decay mapping | 141 |
| 4.6 | File-based management of diagnostic surveys..... | 147 |
| 4.7 | Testing the automatic diagnosis via DA-HBIMM..... | 158 |
| 4.7.1 | Inferential logic in the diagnosis of building decay..... | 158 |
| 4.8 | Web-based documentation, analysis and sharing: the Cloud HBIM portal | 167 |
| 5 | RESULTS AND DISCUSSION | 174 |
| 5.1 | Structuration of results and discussion | 174 |
| 5.2 | Results in reverse engineering: data acquisition and parametric modelling..... | 175 |
| 5.3 | Developments and shortcomings of semantic enrichment methods..... | 180 |

| | | |
|-----|--|-----|
| 5.4 | Image processing towards artificial intelligence | 184 |
| 5.5 | File-based management of diagnostic surveys..... | 186 |
| 5.6 | Automatic diagnosis via DA-HBIMM..... | 187 |
| 5.7 | Web-based documentation, analysis and sharing: the Cloud HBIM portal | 188 |
| 6 | FINAL REMARKS AND FUTURE DEVELOPMENTS..... | 198 |
| | ANNEX A | 204 |
| | ANNEX B | 210 |
| | REFERENCES | 211 |
| | LIST OF FIGURES | 233 |
| | LIST OF TABLES..... | 237 |
| | ACRONYMS..... | 239 |
| | CURRICULUM VITAE | 242 |

EXTENDED ABSTRACT (eng)

The technical and scientific debates agree considering the refurbishment project a challenging process that requires an efficient organization and analysis of the knowledge about the historic artefacts. It is very critical as a result of ambiguities of workflows and information exchanges, dispersion of documentation and the use of inadequate tools to reduce risks caused by these issues. The heritage organisations and professionals are more and more interested in experimenting with innovative methodologies and operative methods to deal with the uncertain context.

In the last ten years, discussions and experiments have been undertaken among experts in digital representation of existing buildings about the use of the Building Information Modelling (BIM) approach, whose conceptualization dates back to the seventies. Nevertheless, this approach has implications and developments in the building, infrastructure and manufacturing domains especially in the present and in projection to the future, thanks to the evolution of the digital tools and methodologies of Industry 4.0 that improve the related methodologies. The most recent studies concern with verifying the feasibility of methods and tools for solving the critical issues inherent in the process of managing the building refurbishment project, in order to reduce the risks of errors in the assessment of the conservation status, firstly, and then in the decision about intervention strategies. The proclivity is towards the search for a holistic approach able to manage a variety of resources generating data and information and different analytic methods for knowledge consolidation, in order to understand the specificities and the complexity of the instances of built heritage. This interest has invested the academic and professional environment at international scale and it is in line with the specific needs and problems linked to the refurbishment project at national level. In practice, interest has been transformed into legal obligations as previously occurring in the English context and now in the Italian one. In effect, the CIC (Construction Industry Council) and the British Government led the program to support the formation of the actors within the construction process in the optics of implementing the government's mandate that projects in the public sector would have been managed with the BIM methodology by

2016. In Italy, the Ministerial Decree 560, 1st December 2017, implementing the Procurement Code (Legislative Decree No. 50/2016), defines the methods and timing of the transition to the BIM of the contracting authorities, administrations and economic operators, the obligatory methods and specific electronic tools. This paradigm shift also involves the refurbishment of existing buildings, prompting a more adequate configuration of the BIM approach. In this case, the reverse engineering has no longer the purpose of translating the geometric survey by photogrammetry or laser scans into 2D plants, elevations and sections, rather being a starting point for three-dimensional modelling, aspiring to move from the solid modelling to parametric objects, geometrically and semantically described. Although significant progress was made in research and development of commercial products for automating this process in presence of objects with simple primitive geometries, further investigation is still needed about architectural elements with complex morphology. In this regard, research lines are exploiting the potential of NURBS (Non Uniform Rational Basis-Splines) and meshes in order to accurately represent elements such as vaults and free-form objects, such as sculptural groups. Some studies have underlined, first of all, the need to disseminate a library of parametric objects of architectural components, continuously updated. However, it is only in the last four years that the need to fill a gap in the HBIM approach emerged, because it could be effectively used in the refurbishment process. This gap concerns the integration of methods of performance evaluation, diagnostics and monitoring within a structured system for quality control of the project, in terms of optimization of time, costs and limitation of errors in diagnosis and choice of the intervention line.

Therefore, the current research began to investigate the methods for the semantic enrichment of the model during some important phases of the refurbishment process, in order to achieve the appropriate Level of Development in terms of information content, as introduced by the UNI EN 11337: 4-2017 standard in the restoration project. The doctoral studies are being directed towards investigation concerning the representation of knowledge, methods and tools for connecting the different sources of data and information (original paper documentation, geometric survey, diagnostic tests, structural and environmental monitoring sensors, etc.), with a propensity to develop systems

devoted to automate diagnosis and support the choice of design, made possible by the versatility of BIM tools based on advanced information technologies (relational databases and cloud platforms, highly customizable). In this perspective, a methodological proposal DA-HBIMM (Diagnosis-aided Historic Building Information Modelling and Management) is introduced, with the aim of automating the diagnosis process by means of algorithms of reasoning, based on a solid Knowledge Base about the phenomena of degradation and failure, and supporting designers in choosing coherent interventions. The damp and crack patterns, so the degradation phenomena, are mapped in 2D and 3D views and the related database shows the semantic attributes about description of damages and building pathologies, images, potential causes, and further data and information. The model is updated through monitoring activities. This specific model, related to the building in a state of decay, can be connected to the 4D-HBIM, the temporal simulation of the transformations and interventions over time, implemented with intervention, in order to support the detection of damages connected with previous human activities. The innovation of the approach is based on the possibility of visualizing, through interrogation tools, the object in the model and its selected properties, to obtain the most efficient sharing of knowledge for all the stakeholders involved (designers, contractors, owners and potential users). In particular, the damp/crack patterns and degradation instances can be isolated and analysed in their informative contents, maintaining their topological relationships within the model. Furthermore, the repository can manage the information obtained from in situ and laboratory tests aimed at the accurate material and technical characterization of the building and its components.

The originality of the DA-HBIMM method in supporting the diagnosis may allow the reduction of further damage to the structure and direct the choice of the most coherent solution for functional recovery, structural consolidation and energy retrofit.

Hence, the research was planned by objectives: first, the critical review of the state of the art inherent to the existing methods and tools of BIM applied to refurbishment aimed at identifying gaps in knowledge, organizing the state of the art for typology of intervention (energy retrofiting and structural reinforcement); subsequently, the tests of some

processes, identified in the literature, were performed and new methods were presented in order to overcome the gaps recognised in the current methodological approaches and to propose a methodological approach.

The applications presented in the research area are diversified in order to test the flexibility of the methodology that can be configured according to the specificity of the case in question, since it is a methodology that finds applicability at international level, therefore in building contexts and infrastructures diversified by building culture, social needs and building systems. The next step is the implementation of a HBIM platform, completely dedicated to the refurbishment and management of the building for the real-time instrumental monitoring and the visualization of in-use conditions of the building. In this case, the management of existing buildings during the operation phase is fully possible, before and after refurbishment operations. In this way, reports and suggestion about mitigation activities can be provided when the thermo-hygrometric conditions do not meet the reference thresholds for occupant comfort, energy consumption must be reduce, or health and safety are at risk.

The proposed methodological approach is devoted to be developed towards the automation of inferential reasoning by exploiting the potentials of computational systems, methods of Image Processing and Surface analysis in the direction of the implementation of Artificial Intelligence, promoting the transition from a file-based collaboration to a data-based type, representing a Level 3 BIM maturity and greater interoperability.

key words

BIM (Building Information Modelling), Historic building, HBIM (Historic Building Information Modelling), Refurbishment, Diagnostics, Diagnosis-Aided HBIMM (DA-HBIMM)

EXTENDED ABSTRACT (ita)

I professionisti e gli accademici concordano nel ritenere che il progetto di recupero sia un processo complesso che richiede un'organizzazione e un'analisi della conoscenza degli artefatti storici efficienti. Il processo è molto critico a causa delle ambiguità dei flussi di lavoro e degli scambi di informazioni, della dispersione della documentazione e dell'uso di strumenti inadeguati per ridurre i rischi causati da questi aspetti. Le organizzazioni e i professionisti del patrimonio sono sempre più interessati a sperimentare metodologie innovative e metodi operativi per affrontare le incertezze intrinseche al contesto.

Negli ultimi dieci anni, gli esperti nella rappresentazione digitale degli edifici esistenti hanno guidato discussioni e sperimentazioni sull'uso dell'approccio BIM (Building Information Modelling), la cui concettualizzazione risale agli anni settanta. Tuttavia, questo approccio ha implicazioni e sviluppi nei settori della costruzione, delle infrastrutture e della produzione, specialmente nel presente e in proiezione verso il futuro, grazie all'evoluzione degli strumenti e i metodi digitali propri dell'Industria 4.0, che migliorano le relative metodologie. Gli studi più recenti riguardano la verifica della fattibilità di metodi e strumenti per risolvere le criticità inerenti al processo di gestione del progetto di recupero degli edifici, al fine di ridurre i rischi di errori nella valutazione dello stato di conservazione, in primo luogo, e quindi nella decisione di strategie di intervento. La propensione è verso la ricerca di un approccio olistico in grado di gestire una varietà di risorse che generano dati e informazioni e diversi metodi analitici per il consolidamento della conoscenza, al fine di comprendere le specificità e la complessità delle istanze del patrimonio costruito. Questo interesse ha investito l'ambiente accademico e professionale su scala internazionale ed è in linea con le esigenze e i problemi specifici legati al progetto di recupero a livello nazionale. In pratica, l'interesse è stato trasformato in obblighi di legge, come prima nel contesto inglese, ed ora, in quello italiano.

In effetti, il CIC (Construction Industry Council) e il governo britannico hanno condotto il programma per sostenere la formazione degli attori all'interno del processo di costruzione nell'ottica di attuare il mandato del governo che imponeva la gestione dei progetti

nel settore pubblico con la metodologia BIM entro il 2016. In Italia, il Decreto Ministeriale 560, 1 ° dicembre 2017, che attua il Codice degli appalti (d.lgs. n. 50/2016), definisce le modalità e i tempi della transizione al BIM delle amministrazioni aggiudicatrici, delle amministrazioni e degli operatori economici, i metodi e gli strumenti elettronici specifici. Questo cambio di paradigma coinvolge anche il recupero degli edifici esistenti, suggerendo una configurazione più adeguata dell'approccio BIM. In questo caso, l'ingegneria inversa non ha più lo scopo di tradurre il rilievo geometrico mediante fotogrammetria o scansioni laser in piante, prospetti e sezioni bidimensionali, piuttosto come punto di partenza per la modellazione tridimensionale, aspirando a passare dalla modellazione solida agli oggetti parametrici, descritti geometricamente e semanticamente. Sebbene siano stati fatti progressi significativi nella ricerca e nello sviluppo di prodotti commerciali per automatizzare questo processo in presenza di oggetti con geometrie primitive semplici, sono ancora necessarie ulteriori indagini sugli elementi architettonici con morfologia complessa. A questo proposito, le linee di ricerca stanno sfruttando il potenziale delle NURBS (Non Uniform Rational Basis-Splines) e mesh per rappresentare in modo accurato elementi quali le volte e gli oggetti a forma libera, come ad esempio i gruppi scultorei. In primo luogo, alcuni studi hanno sottolineato la necessità di divulgare una biblioteca di oggetti parametrici di componenti architettonici, continuamente aggiornata. Tuttavia, è solo negli ultimi quattro anni che è emersa la necessità di colmare una lacuna nell'approccio HBIM (Historic Building Information Modeling), l'estensione del BIM agli edifici esistenti) perché potrebbe essere efficacemente utilizzato nel processo di recupero. Questo gap riguarda l'integrazione di metodi di valutazione delle prestazioni, diagnostica e monitoraggio all'interno di un sistema strutturato per il controllo di qualità del progetto, in termini di ottimizzazione dei tempi, costi e limitazione di errori nella diagnosi e nella scelta della linea di intervento.

Pertanto, la ricerca presentata in questo lavoro dottorale ha iniziato ad indagare i metodi per l'arricchimento semantico del modello durante alcune fasi importanti del processo di recupero, al fine di raggiungere il livello di sviluppo appropriato in termini di contenuto informativo, introdotto dalla UNI EN 11337: standard 4-2017 nel progetto di restauro.

Gli studi di dottorato sono indirizzati all'indagine riguardante la rappresentazione della conoscenza, metodi e strumenti per collegare le diverse fonti di dati e informazioni (documentazione cartacea originale, rilievo geometrico, test diagnostici, sensori di monitoraggio strutturale e ambientale, ecc.), con una propensione allo sviluppo di sistemi dedicati ad automatizzare la diagnosi e supportare la scelta progettuale, resa possibile dalla versatilità degli strumenti BIM basati su tecnologie informatiche avanzate (database relazionali e piattaforme cloud altamente personalizzabili). In questa prospettiva, viene presentata una proposta metodologica DA-HBIMM (Modellazione e gestione delle informazioni sull'edilizia storica assistita dalla diagnosi), con l'obiettivo di automatizzare il processo di diagnosi mediante algoritmi di ragionamento, basato su una solida base di conoscenza sui fenomeni di degrado e lesionativi e supportare i progettisti nella scelta di interventi coerenti. I quadri umidi e lesionativi, così i fenomeni patologici, sono mappati in viste 2D e 3D e il database correlato mostra gli attributi semantici sulla descrizione dei danni, immagini, cause potenziali e ulteriori dati e informazioni. Il modello viene aggiornato tramite le attività di monitoraggio. Questo modello specifico dell'edificio in uno stato di degrado, può essere collegato al 4D-HBIM, la simulazione temporale delle trasformazioni e degli interventi nel tempo, al fine di supportare il rilevamento dei danni connessi con precedenti attività antropiche. L'innovazione dell'approccio si basa sulla possibilità di visualizzare, attraverso strumenti di interrogazione, l'oggetto nel modello e le sue proprietà selezionate, per ottenere la più efficiente condivisione della conoscenza per tutti gli stakeholders coinvolti (progettisti, imprenditori, proprietari e potenziali utenti). In particolare, i quadri umidi/lesionativi e le condizioni di degrado possono essere isolati e analizzati nei loro contenuti informativi, mantenendo le loro relazioni topologiche all'interno del modello. Inoltre, il repository è in grado di gestire le informazioni ottenute da test in situ e di laboratorio finalizzati alla accurata caratterizzazione materico-costruttiva dell'edificio e dei suoi componenti.

L'originalità del metodo DA-HBIMM nel supportare la diagnosi può consentire la riduzione di ulteriori danni alla struttura e indirizzare la scelta della soluzione più coerente per il recupero funzionale, il consolidamento strutturale e il retrofit energetico.

Pertanto, la ricerca è stata programmata per obiettivi: prima, la revisione critica dello stato dell'arte inerente ai metodi e agli strumenti esistenti del BIM applicato al recupero per identificare lacune nella conoscenza, organizzando lo stato dell'arte per tipologia di intervento (retrofitting energetico e rinforzo strutturale); successivamente sono stati eseguiti i test di alcuni dei processi individuati in letteratura e presentati nuovi metodi al fine di superare le lacune individuate nei correnti approcci metodologici e strutturarne una proposta.

Le applicazioni presentate nell'area di ricerca sono diversificate per testare la flessibilità della metodologia che può essere configurata in base alla specificità del caso in questione, poiché è una metodologia che trova applicabilità a livello internazionale, quindi in contesti costruttivi e infrastrutture diversificate per tradizioni culturali, bisogni sociali e sistemi di costruzione. Il passo successivo è l'implementazione di una piattaforma HBIM, completamente dedicata al recupero e alla gestione dell'edificio permettendo il monitoraggio strumentale in tempo reale e la visualizzazione delle condizioni ambientali dell'edificio. In questo caso, la gestione degli edifici esistenti durante la fase operativa è completamente possibile, prima e dopo le operazioni di retrofitting energetico. In questo modo, è possibile fornire suggerimenti sulle attività di mitigazione quando le condizioni termo-igrometriche non soddisfano le soglie di riferimento per il comfort degli occupanti, il consumo di energia deve essere ridotto o quando la salute e la sicurezza degli utenti sono a rischio. L'approccio metodologico proposto è dedicato allo sviluppo dell'automazione del ragionamento inferenziale sfruttando le potenzialità dei sistemi computazionali, dei metodi di Image Processing e Surface analysis verso l'implementazione dell'Intelligenza Artificiale, promuovendo il passaggio da una *collaborazione file-based* ad una di tipo *data-based* che rappresenta una maturità BIM di Livello 3 ed una maggiore interoperabilità.

key words

BIM (Building Information Modelling), Historic building, HBIM (Historic Building Information Modelling), Refurbishment, Diagnostics, Diagnosis-Aided HBIMM (DA-HBIMM)

INTRODUCTION

The complexity and specificity of each specimen of the built heritage and the difficulty in the retrieval of exhaustive knowledge have consequences on the effectiveness of refurbishment activities (energy retrofitting, structural reinforcement and functional change). Indeed, an uncertain knowledge, as result of fragmented data and information and ambiguities of workflow and information exchange, can lead to errors in the evaluation of the building conditions, decay and damage phenomena, material and constructive features and transformation over time. The limited collection of real data generates errors in performance modelling that rise whether there are losses in information delivery.

Consequently, this context activates potential risks in the selection of incoherent interventions, which can compromise the significance of historic buildings, the health and safety of users for undermined static and dynamic equilibrium, the indoor air quality and the energy savings. This complexity is translated in the interrelation of multiple agents and variables that may be structurally interpreted and reconstructed in order to formulate the correct diagnosis and intervene on actual causes.

In light of the negative results of some refurbishment interventions that have worsened the performance conditions, the need of proposing a methodological approach emerges with the aim of solving the process criticalities, sharing and analysis of the available data. For example, some historic buildings have undergone forbidden transformations and demolitions that have compromised the structural equilibrium and

inflicted global static and dynamic behaviour. Furthermore, buildings subjected to energy retrofitting interventions - with installation of external or internal insulation and windows with high air tightness - can lead to poor indoor air quality, favouring an internal micro-climate that increases the risk of surface or interstitial condensation, thermal bridges, and mould growth.

The Industry 4.0 could provide digital tools and Information & Communication Technologies (ICT) methodologies for positively supporting refurbishment process. In the last decade, the Historic Building Information Modelling (HBIM) approach have been investigated by international research groups with the aim of documenting and managing the knowledge in order to execute sustainable redeployment and reuse of the built heritage. The missing link is between the knowledge acquisition and the refurbishment project, in the optics of automating the analysis of captured data for damage detection, performance assessment, selection of interventions, real-time alerts and early warning mitigation measures.

By recently, the scarce awareness of the real building and infrastructure conditions caused structural failures or erroneous choices in energy retrofitting, with negative effects on the health and safety of users and indoor environmental quality respectively.

The integration of BIM and Building Management Systems (BMS) is found to be a possible practical solution for performance optimization, with the cognizance that the execution of the intervention and the handover of the retrofitted building to the users may be accompanied by an initial support for effective construction and use of the building in order to avoid discrepancies between the simulation and the actual behaviour.

Therefore, an effort in changing cultural paradigm may initiate in the roadmap from the use of separate paperwork, as traditional reports of diagnostic tests and other documentation, to integrated web services. In order to address these goals, an integrated tool must traduce the human cognitive capability into a machine-driven diagnosis and project with the ability of problem-solving.

Another aspect needs to be clarified in order to establish a valid and extensive methodology. The refurbishment can interest different typologies of buildings, in terms of pe-

riod of construction, constructive techniques, functional use, local traditions and environmental and climate conditions, and this peculiarity imposes the contribution of the professionals in selecting suitable methods and tools, advancing preliminary hypothesis and accepting or calibrating the results of the automatic machine-driven reasoning. After a critical literature review about the methodologies and tools investigated in projects coordinated with BIM and HBIM (chapter 2), a methodological approach has been proposed for implementing the Diagnosis-Aided Historic Building Information Modelling (chapter 3) with the perspective of testing the feasibility of the paradigmatic approach to face these issues (chapter 4).

The methodology consists of different steps, methods and tools tested on two different groups of case studies: unoccupied historic buildings in stone bricks masonry (South Italy) and occupied historic and existing buildings in no-fine concrete facades or in solid walls (United Kingdom) where indoor environmental quality can be potentially affected after energy retrofitting due to differences between simulated and measured boundary conditions, erroneous retrofitting techniques and occupant's behaviour. The chapter 5 delineates findings and discussions about the different applications of the DA-HBIMM proposed and tested, in order to highlight lines of further investigations within an extensive framework (chapter 6).

1 INNOVATIVE APPROACHES IN REFURBISHMENT

1.1 The role of incremental knowledge in refurbishment

The refurbishment projects are featured by a high level of complexity and uncertainty the project team may deal with through an *a-priori* organized and efficient management workflow. It is confirmed that the knowledge is generally sparse in the management of refurbishment (Rahmat, 1997) and new management methods and tools are required.

Several variables contribute to the complexity and uncertainty but the acquisition of knowledge about the fabric is a challenging aspect as a preliminary task in the refurbishment project. Certainly, incremental knowledge has a fundamental role in order to reduce uncertainties by surveys, inspection, assessment, diagnosis and recording, but it is a complex and strategic stage involving a number of actors in a multidisciplinary approach to be aware of unexpected data and information (Vicente et al., 2015). The incremental and accurate knowledge by investigation of physical and performance parameters supports the evaluation of the state of conservation as the stable principle for non-invasive interventions to ensure the valorisation of the Cultural Heritage (Bruno et al., 2018). The data and information incrementally added permits data quality control and verification (Thabet et al., 2016).

The ICOMOS charter (ISCARSAH (International Scientific Committee for Analysis and Restoration of Structures of Architectural Heritage), 2003) guides the knowledge phase establishing the objectives of surveys and diagnosis such as the complete understanding of the structural behaviour and the qualification of the building materials. The aims

are investigating techniques and construction methods used, subsequent transformations over time, present conservation state, etc. In addition, the diagnosis requires the integration of historical information within qualitative and quantitative approaches. The quality of these processes affects the planning of performance the building may have after energy retrofitting, structural consolidation and planned maintenance in order to guarantee technical efficiency and durability. The evaluation of the state of conservation should not be a neglected step (Quagliarini et al., 2016) because it aims at eliminating the impacts on integrity and authenticity that could lead to the damage and the deprivation of the symbol of a community (Cursi et al., 2015)(Brumana et al., 2017). In order to deal with this challenging task, it is essential to diagnose the forms of deterioration and failure in an accurate manner, limiting errors, in order to identify the real causes and intervene on them through reversible and consistent measures (ISCARSAH (International Scientific Committee for Analysis and Restoration of Structures of Architectural Heritage), 2003) (Fatiguso et al., 2016). Understanding of damage is another complex task that requires the involvement, integration and interpretation of a great amount of information. Sometimes, the defects are caused by ignorance and lack of knowledge about shortcomings of standards and codes, errors and negligence of experts (e.g. design and detailing errors or procedural errors (Cacciotti et al., 2015). The consecutive and related phase of diagnosis is safety assessment (or risk assessment) with the aim of evaluating the “effective need for and extent of treatment measures” (ISCARSAH (International Scientific Committee for Analysis and Restoration of Structures of Architectural Heritage), 2003).

Nevertheless, the traditional information management stands on a documentation-based informative system, where information about the existing building is stored in incremental, not structured archives (or databases) (Cursi et al., 2015) as a collection of fragmented documentation (Historic England, 2017)(Volk et al., 2014)(Gerrish et al., 2015). This issue can lead to erroneous diagnosis of damage and building pathologies, thus an integrated approach may support correlating, exchanging and interpreting the information and data to eliminate consequent risks. In addition, another aspect that

contributes to the resolution of critical issues intrinsic to the formulation of the diagnosis concerns the effective sharing of knowledge, in order to intervene in a consistent manner and contain the costs and risks of compromising the factory.

1.1.1 Risks in erroneous diagnosis of building pathologies and damages

A knowledge system must be set up in order to direct professionals through a guided decision-making process to mitigate the risks associated with the diagnosis of damages. The incorrect diagnosis and risk assessment result in subjective decisions about the execution of heavy-handed conservation measures or the evaluation of inadequate safety levels (ISCARSAH (International Scientific Committee for Analysis and Restoration of Structures of Architectural Heritage), 2003).

The risks generated by incorrect diagnosis are numerous and affects:

- the historic asset, its value and significance;
- the authenticity and compatibility with the original;
- design errors and procedural errors;
- low durability of materials;
- low compatibility of materials;
- worst structural behaviour;
- condensation and mould growth risk after energy retrofitting;
- higher energy consumption than predicted values;
- underestimating risk for health and safety;
- costs;
- execution time;
- interferences with the use of the building, if occupied.

The objective diagnosis and assessment may take into account the uncertain data, laws, models, assumptions, that have consequences on the representation of real phenomena, in order to plan how to combine the contribution of different approaches and surveys in order to have the best possible verdict (ISCARSAH (International Scientific Committee for Analysis and Restoration of Structures of Architectural Heritage), 2003).

In this perspective, a good practice is indicating the reliability of the data employed, of the results and the acceptability of selected interventions.

1.1.2 Methods of investigation

The limitation of errors depends on the correlation of results from different methods of investigation via qualitative and quantitative approach, the last one possible also via observation and monitoring of the actual behaviour with the aim of identifying concomitant causes from data often about the effects. The qualitative analysis depends on the experience of experts in comparing similar cases and for increasing the reliability of intuitions via monitoring the performances (ISCARSAH (International Scientific Committee for Analysis and Restoration of Structures of Architectural Heritage), 2003). The quantitative analysis consists of the experimental and analytical studies, such as structural analysis. In detail, non-destructive, mildly-destructive or destructive diagnostic tests support the characterization of materials and diagnosis. Among the most adopted surveys such as Ground Penetrating Radar (GPR), sonic and ultrasonic tests, thermography, drilling borehole and flat jack, new approaches have been investigating for remotely identifying geometry, component materials, and damage employing Remote Sensing techniques, a non-contact approach, and analytic studies of acquired data (such as surface analysis, image processing, spectrometry) (Laefer et al., 2018). These last techniques requires less expensive equipment, invasive and time consuming for the study of superficial features of the building, also at city-scale. The traditional investigations support the qualification of hidden characteristic of constructive techniques (Fatiguso et al., 2017).

The required approach to reduce uncertainty and errors is finding innovative methods to combine the results of programmed surveys, after converting them in computer-readable data (Cacciotti et al., 2015)(Bruno et al., 2018).

1.2 Innovative management of integrated data and information

In literature, some research works have been found regarding the structuring of informative systems for the systematized and coordinated management of the diagnostic phase. Platforms and applications for mobile devices have been developed. MONDIS based on the ontological model of diagnosis for the insertion and research of data concerning the causes of decay and possible remedies through the automatic reasoning at the base of the diagnostic model (Cacciotti et al., 2015). MONUMENTUM, an ontological model for recording and integrating multidisciplinary observations of the conservation state into structural data as semantic-aware 3D representation (transformations over time, the knowledge of buildings and architectural rules, and the representation of forms of decay)(Messaoudi et al., 2018).

Conversely, there is a missing connection between the knowledge and diagnosis phase and the refurbishment project, which begins from the set of information and data obtained from different sources and available in heterogeneous formats.

The Building Information Modelling approach, devolved to refurbishment with the concept of Historic Building Information Modelling (HBIM)(Murphy et al., 2009), has proved to be a flexible approach for design because of implementation of tools and practices inherited by the Information & Communication Technologies.

Furthermore, there are more and more available and open-source scripts for programming custom algorithms helpful for the creation of plug-ins or add-ons of BIM tools, as for the creation of web-based software (through Cloud Computing) for the connection of data from different databases and sensor networks, as well as the facilitation of knowledge sharing among people working in different geographical locations ('Autodesk Forge', 2016)

1.2.1 The contribute of Building Information Modelling

Building Information Modelling (BIM) is not an innovative technology because it was born in 1980s for manufacturing as object-based parametric modelling, an evolution of

CAD design where objects present fixed geometry and properties. Conversely, the BIM functions employ parameters and rules for generating geometry and analysing non-geometric properties and features (Eastman et al., 2011). It has been developing in a more effective collaborative process in the architectural, engineering, construction and operation (AECO) industry, mainly in the new constructions.

Building Information Modelling is a new paradigm of digital design and management and it can be a guide tool for work and information flows as long as it stands on the concept of integrated digital archive that collects geometric, semantic and topological data, in different formats and contents, within parametric objects (Eastman et al., 2011). BIM proprietary or customised tools can manage and analyse the multiplicity of variables due to query operations and specific programmed automation algorithms.

The benefits that BIM may produce in the refurbishment are related to the effective involvement of all the technicians with multidisciplinary skills and the successful information sharing. The integration of BIM with automation systems would positively support the quality control during diagnosis, design and work execution as well as labour savings. The BIM approach can be very attractive for the management of the comprehensive and incremental knowledge of the built heritage, fundamental activity for an accurate assessment of the residual building performances to be recovered by refurbishment and retrofit but affected by criticalities, as it is the integration of a variety of information through independent and structured methods.

In 2009, Murphy (Murphy et al., 2009) introduced the term Historic Building Information Modelling (HBIM) as an application of BIM in the built heritage for geometric modelling starting from laser scanning, photogrammetry and architectural rules. Consecutively, an evolution has occurred including the concept of information management leading to Built Heritage Information Modelling and Management (BHIMM) (Ciribini et al., 2015). Recently, researches worldwide published literature reviews about BIM for existing buildings because further developments are required to be very effective in the refurbishment process (Volk et al., 2014)(Ilter and Ergen, 2015)(Logothetis et al., 2015)(Bruno et al., 2017a)(López et al., 2018)(Pocobelli et al., 2018b). Some of them

focus on the phase of geometric surveys and parametric modelling, highlighting advances and technical issues in automating this task, others remark the need of guidelines, specific technologies for handling heritage-related knowledge about building conditions and intangible information (Fai et al., 2011)(memories, historical photos, music, etc.) (Bruno and Fatiguso, 2018)(Bruno et al., 2018)(Pocobelli et al., 2018b).

BIM tools are software programs (more or less interoperable) and databases that support the organisation and the collection of information, which is disconnected and sometimes unavailable, and reported in separate sources.

Before the literature review, some premises/definitions and international and national standards are provided to understand the BIM methodology and the research methodology of the PhD contribution.

1.2.2 Premises and definitions

The BIM technology aims at generating a digital representation of a building, including physical and functional features in a multi-dimensional approach according to the use and objectives of BIM models and additional information (Megahed, 2015)(Logothetis et al., 2015). The 3D collaborative models are the evolution of 2D drawings for documentation, but they can be employed for easily extracting them. The addition of time scheduling allows virtual construction and space-conflict identification (clash detection)(4D). The 5D models integrates a 3D model with time, quantity take-off and cost estimates for owners, project engineers, and managers. The last two dimensions are not well defined; in general, the sustainability of the entire building's lifecycle project consists of the 6D, and the use of all the precedent models support the facility management, maintenance and operation (7D) (McArthur, 2015)(Megahed, 2015).

An important capability of the BIM approach is the provision of a tool for assessing design options, according to different decision criteria (time, cost, etc.) and giving results in short time, increasing quality and productivity of the project and reducing defects and risks (Logothetis et al., 2015).

The management of graphical and non-graphical information begins with the definition of level of details, a concept with different definitions and specifications.

In USA, the Level of Development (LOD) consists of the content of objects in Building Information Models, corresponding to the stages in the design and construction process (AIA, 2013)(BIMForum, 2018), and organized by CSI Unifomat 2010. The model progression is defined by the modeller specifying the level of reliability, usability and limitations of the models. In UK, the (PAS 1192-2, 2013) defines the Level of Definition, as Level of Detail (LoD) and Level of Information (LoI). The LoD refers to graphical elements, the LoI refers to the description of non-graphical information. In Italy, the concepts regain the English specifications introducing LOD for restoration activities (LOD F and G)(UNI/CT033, 2017).

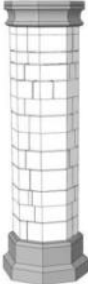
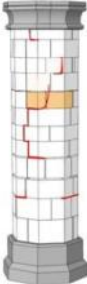
| LOG F | LOG G |
|--|---|
|  |  |
| <p>The object is graphically virtualised with a detailed geometric system. The dimension, shape, location and orientation are specific and correct. All the components of the object are represented in 3D and reflect the as build condition.</p> | <p>The object is graphically virtualised with a detailed geometric system. The dimension, shape, location and orientation are specific and updated, taking into account the entire life cycle and the previous state of the art. The 3D geometric representation must be provided when elements are restored or replaced. The level of degradation must be represented.</p> |

RESTORATION

Level of Information – Column

LOI F – complete identification and description of the element (form, locations, size, orientation, relations with other elements, materials analysis, processes, forms of degradation/damage/instability, diagnosis, past interventions, monitoring. Planning of the inspection and periodic interventions.

LOI G – LOI F integrated with the information collected during the management phases (inspection data, monitoring data, registration of periodic and maintenance intervention (unexpected).

Figure 1.2-1 UNI 11337-3-2017 draft of the proposed LoG-LoI ('F and G'). Source: (Brumana et al., 2017)

In UK, the Government established a tool for investigating the degree of BIM implementation, the BIM maturity graph, expecting the construction sector would reach BIM maturity level 2 by 2016. The BIM maturity graph is based on the Bew and Richards BIM maturity levels (PAS 1192-2, 2013).

The BIM maturity Levels are distinguished as following:

BIM Stage 1 (level 0-1): it is the path from unmanaged paper deliverables to managed Computer Aided Design (CAD), both in 2D or 3D formats. The actors employ individual and non-connected data and software tools (Succar, 2010)(Mahamadu, 2017);

BIM Stage 2 (level 2): a collaborative 3D model is the system for information management, where data is embedded within 3D BIM objects (library management and file based collaboration). Consequently, data is generated and utilized in separate proprietary tools. The PAS 1192:2:2013 explains that actors must aim at employing software products with the highest level of interoperability they can. The data and information must be provided in a single environment, called Common Data Environment (CDE), *“used to collect, manage and disseminate all relevant approved project documents for multi-disciplinary teams in a managed process”* (PAS 1192-2, 2013).

BIM Stage 3 (level 3): in this stage, fully open and interoperable processes are employed following standards, such as Industry Foundation Class (IFC)¹, International Framework for Dictionaries (IFD)², Information Delivery Manuals (IDM)³, etc. The use

¹ Industry Foundation Classes (IFC): is a data model for describing building and construction industry data, platform neutral, an object-based open file format specification, developed by buildingSMART (formerly the International Alliance for Interoperability, IA) to facilitate interoperability in the architecture, engineering and construction (AEC) industry (ISO/TC184/SC4, 2013).

Because of its focus on ease of interoperability between software platforms, the Danish government has made the use of IFC format(s) compulsory for publicly aided building projects. Also, the Finnish state-owned facility management company Senate Properties demands use of IFC compatible software and BIM in all their projects. The Norwegian Government, Health and Defense client organisations require use of IFC BIM in all projects as well as many municipalities, private clients, contractors and designers have integrated IFC BIM in their business.

² International Framework for Dictionaries (IFD): for building product specifications, to be used in different applications, such as energy analysis, carbon footprint, and cost estimation (ISO/TC59/SC13, 2007).

³ Information Delivery Manual (IDM): for linking the BIM model with expert functionalities providing relevant information, facilitating data exchange and avoiding ambiguities (ISO/TC59/SC13, 2016).

of integrated web-services (platform model servers) will enhance interoperable processes and data-based handling.

The interoperability is “the ability of two or more systems or components to exchange information and to use the information that has been exchanged” “among multiple parties that use different software vendors without the loss of information, thus enabling collaboration” (Succar, 2009)(Mahamadu, 2017).

1.2.3 Standards and guidelines for HBIM implementation

The COTAC (Council on Training in Architecture Conservation) reported that the HBIM could be an approach for operating on the existing building stock, but paying attention to identify value, significance and accurately surveyed data. Indeed, HBIM supports the coordination of multi-disciplinary knowledge, avoiding errors caused by inaccurate, incomplete or sparse information across different locations and different formats (Maxwell, 2014)(Maxwell, 2016a). Nevertheless, a systematic approach is required according to the objectives and use of HBIM (Maxwell, 2016b), pursuing to go beyond the high-quality digital survey datasets towards the analysis of alternatives of intervention. The HBIM model can support decision-making and management if efficiently maintained (Historic England, 2017). The time-based BIM use (4D) can be employed for analysis of historic building transformation and interventions over time, comparison of alternative interventions, clash detection for coordinating the interventions against the existing fabric, the coordination of heterogeneous datasets (historic information, legacy data, photographs and drawings, geospatial datasets, geophysics and remotely sensed data and imagery, intangible information, interoperability for data sharing and reuse across a multi-disciplinary team, potential for interfacing with other enterprise systems, such as GIS, CAFM, databases and archives. Nevertheless, these documentations and reports about the implementation of HBIM for English heritage buildings proposed the investigation of methods for condition monitoring, diagnosis of building pathologies and damages, and performance assessment (Maxwell, 2014)(Historic England, 2017).

In England, the BIM, as outlined in the CIC BIM Cyclical Diagram, requires calibration for working in the refurbishment/restoration of historic buildings (Maxwell, 2016a).

The proposal is overlaying individual HBIM factors in an iterative flowchart, in order to relate decisions for every new use for the building emerged, and additional factors are required to be analysed (Figure 1.2-2).

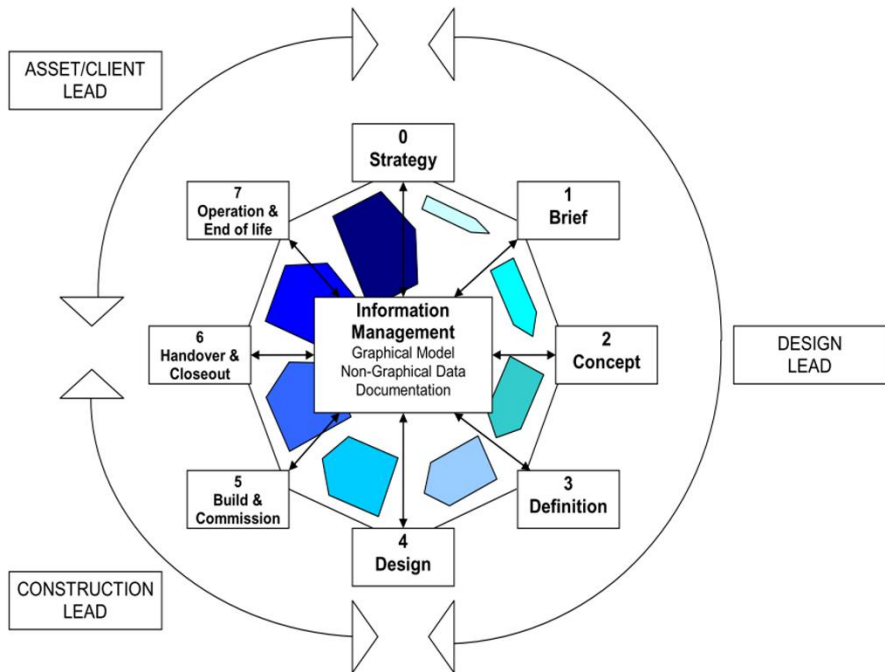

Figure 1.2-2 CIC BIM Cyclical Diagram and COTAC HBIM Cyclical Diagram. Source: (Maxwell, 2016a)

The *3_Define Detailed Survey* and *4_Determining Intervention*, belonging to the '*Information Management Graphical Model Documentation*', are the focus activities of the PhD study.

In the professional practice, the BIM standards and guidelines may be understood contemporarily with international documentations about conservation of historic assets (ISCARSAH (International Scientific Committee for Analysis and Restoration of Structures of Architectural Heritage), 2003).

The BS7913: 2013 introduces a cyclical procedural Flow Chart in order to provide a decision-making process, considering these points:

- Drivers for change
- Informed viewpoint
- Opportunities and options
- Develop brief and proposals
- Agree solution
- Works phases
- Post project review
- Arrange for regular maintenance.

Decay mapping (degradation details), diagnostic tests and condition monitoring have place within the Definition and Determination of interventions (Maxwell, 2014)(Maxwell, 2016a)(Figure 1.2-3).

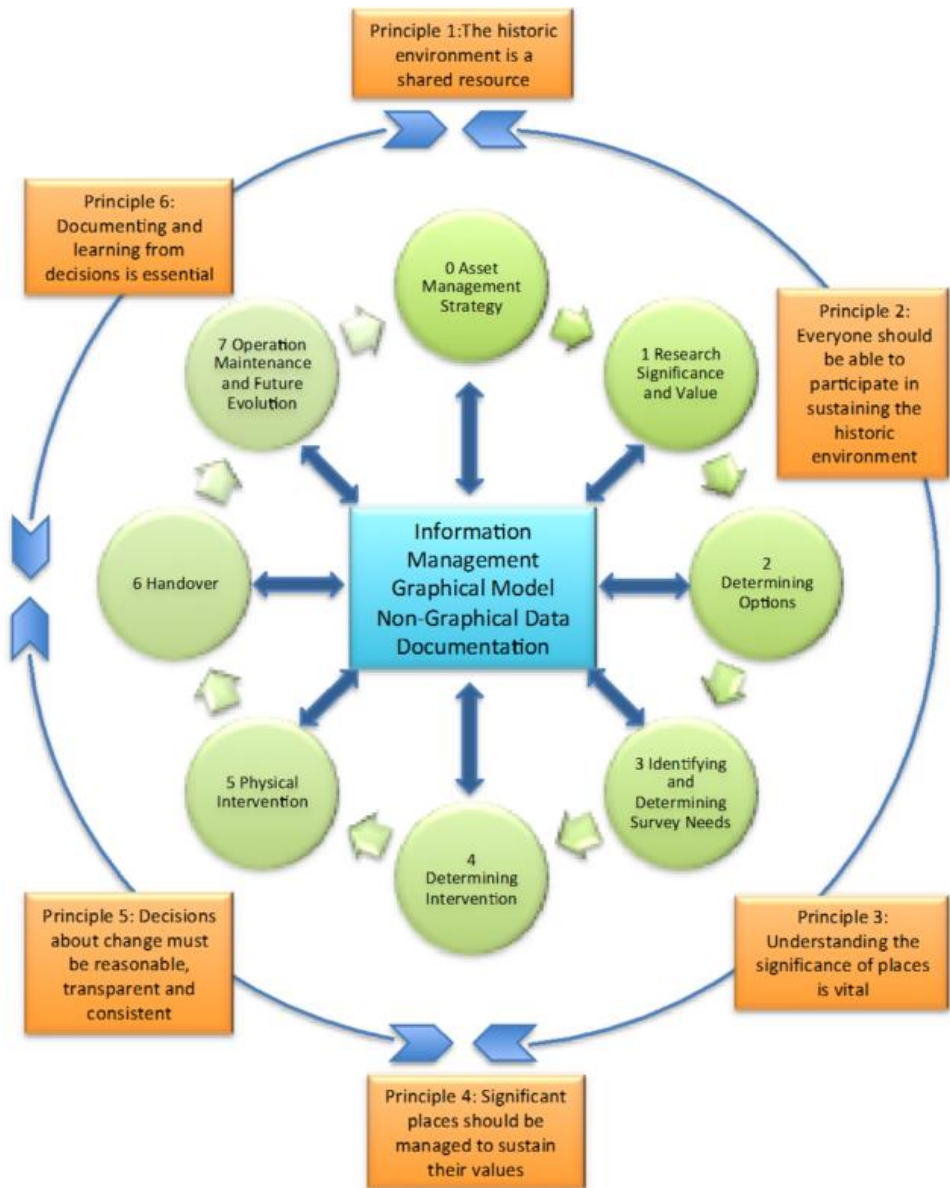

Figure 1.2-3 Application of Historic England Conservation Principles (Maxwell, 2016a).

Historic Scotland “translates” this definition into a heritage-specific language:

- “Level 0: this could refer to a scenario where survey information is manually obtained on site using tapes and dumpy levels, drawn up using a CAD package in an unstructured format, and then communicated using paper plots.”
- “Level 1: this could be a scenario where the site data is obtained digitally with an EDM (electronic distance meter, commonly known as “Total Station”) and then transferred to a 2D or 3D CAD environment that uses standardised data structures.”
- “Level 2: this could be a scenario where the site data is obtained digitally in an inherently 3D format using a laser scanner, for instance, which is then transferred to a discipline-specific, standardised, parametric 3D modelling environment, but communicates and collaborates with other disciplines using industry-standard interface tools (e.g., IFCs). [...]”

It is worth noticing that no Level 3 is considered for heritage buildings. Note as well that, while the industry definitions of these levels include non-structural information such as cost, their heritage equivalents concentrate exclusively on the geometry of the building. Tendencies in BIM for heritage are the creation of HBIM models that have a maturity level of 2,5 i.e. which geometrical data have been derived through automatic procedures—such as laser scanning sessions—and the BIM model is created through parametric objects.

2 STATE OF THE ART

2.1 Literature review methodology

In this context, this revision of the state-of-the-art is drawn up for the following purposes: 1) analysing criticalities and potentialities of HBIMM, as emerged in refereed publications; 2) formalising the first attempts of HBIMM application; 3) proposing a methodological flow to be consolidated; 4) suggesting future developments toward a Diagnosis-Aided HBIMM (DA-HBIMM) within an automation-based framework.

The projection is the development of systems able to perform diagnostics through the automatic computation of data recovered from different channels (analysis of past transformations, visual inspection, image processing, diagnostic tests, monitoring, etc. with a projection towards the implementation of artificial intelligence techniques in refurbishment (Bruno et al., 2018).

The aim of this state of the art is to identify gaps in knowledge and to provide insights for future development on methods and tools of Historic Building Information Modelling for the refurbishment project, toward the automated diagnosis of the residual performances and design of coherent structural reinforcement and energy retrofitting. In addition, relevant issues, investigated within this work, concern knowledge acquisition and management of the diagnosis, with the future perspective of automatic performance assessment within the BIM approach, in order to achieve accurate and precise performance assessment in acceptable time, as well as in risk situations. Therefore, this article excludes the project phase - analysis and simulation of design trade-offs,

graphs and documents, scheduling, cost estimation, etc. The originality of the state of the art, compared to the works by Volk et al., 2014 (Volk et al., 2014) and Ilter and Erger, 2015 (Ilter and Erger, 2015), stands on the focused specific gaps and possible developments of BIM for diagnosis and performance assessment, also by integrating diagnostic tests and monitoring measurements.

The current literature review regards scientific and technical contributions from 2004 to 2017, following the research methodology illustrated in Figure 2.1-1.

It begins with the Data collection of contributions by the listed keywords, successively analysed with a first Bibliometric study about HBIM (Section 3). The consultation and selection of the research works among scientific publications and pilot projects was carried out via Scopus, ScienceDirect, Google Scholar, ASCE library, "white papers" sections of construction companies and software houses. Among the selected sources, 120 contributions, 86 with international impact, and 1 project were analysed. Among them, 13 articles include the word HBIM in title, abstract, keywords or paper body.

The bibliometric study concerns the papers with keywords correspondent to BIM approach to existing buildings, investigating impact of different denominations over the years. The scope of Section 3 relies on analysing trends, from 2007 to 2017, of HBIM methodology and the distribution by typology of sources (journals, conference proceedings, books, etc.), in order to evaluate the international interest of the technical and scientific community.

Section 4 regards the Critical analysis, conducted after screening the papers by selected Criteria. These themes are reported in Figure 2.1-1, and correspond to the structure of the paragraphs in Sections 4 and 5.

To expand, the first step of the critical analysis concerns principles and methods of understanding adequate approaches that are worthwhile in managing the performance assessment and the diagnosis by BIM logic. In this perspective, the exploration of information management and exchange tasks provides insights into information classification and representation, information management standards and protocols, and available BIM services for knowledge sharing and reuse.

Moreover, the second step of the critical analysis is the core of the review of the HBIM model, as well as diagnosis and performance assessment features. As starting point, the identification of such tasks in the traditional construction practices is carried out to delineate further development of the BIM approach in the building refurbishment. In addition, articles on innovative workflows in Facility Management (FM) for new buildings are considered a guide for extending the BIM vision to the existing buildings. For this reason, the selected papers regard the refurbishment workflows as traditional or BIM-compliant processes and applications of BIM for diagnostics and monitoring on infrastructure, where both academic articles and professional practice prove effective inclusion in BIM for rehabilitation. The objective is to extract the relevant aspects of traditional methods of planning and executing interventions and to identify possible answers to some revealed open issues in the HBIM specific domain.

The review of scientific and technical contributions of geometric survey, visual inspection and parametric modelling is an analysis of trends, methods and tools of parametric modelling from acquired point clouds in HBIM, as well as the level of automation from reverse engineering to HBIM. The paragraph on the implementation of diagnostics and monitoring data in BIM includes integrated applications of BIM with diagnostics and monitoring, firstly analysing literature on implementation of diagnosis and monitoring for energy retrofitting and structural reinforcement in traditional and HBIM-aided processes. The new approaches and tools are also investigated.

The critical analysis tracks the Gaps-in-knowledge from the current theories and practices to be solved with the proposal of future developments. Gaps and developments are herein discussed by the same selected criteria of diagnosis and performance assessment in Section 5. Following the discussion of the obtained results, a Diagnosis-Aided Historic Building Information Modelling and Management (DA-HBIMM) is proposed for data acquisition, processing, organisation and exchange techniques, focusing the attention on activities that deserve a role within the digital approach to the refurbishment process: diagnosis and performance assessment through geometric survey, traditional and augmented visual inspection, experimental diagnostics and monitoring.

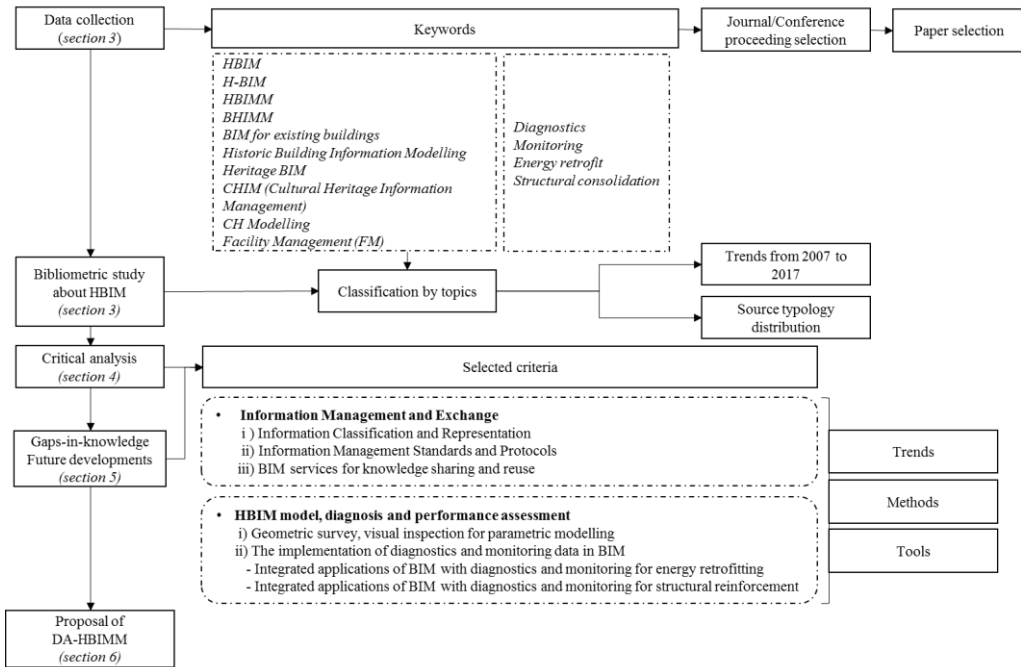

Figure 2.1-1 Literature review methodology. Source: author.

2.2 Data collection and bibliometric approach about HBIM

According to the aforementioned methodology, the phase of Data collection of the scientific literature is primarily based on the research of published contributions by keywords. All the analysed projects (1) and research works (86) (concerning BIM, HBIM and diagnostics/monitoring) are then classified according to source type, namely journals, conference proceedings, white papers, regulations and books and the year, as shown in Table 2.2-1. Particularly, it was found that the papers, mostly written in 2015 (23), are mainly scientific contributions in journals (51), while the 23 works are reported in publications in conference proceedings. Moreover, a high number of papers were written in ISPRS - International Archives of the Photogrammetry, Remote Sensing and Spatial Information Sciences (11) and in Automation in Construction journal (8).

| Journals | 2004 | 2007 | 2008 | 2009 | 2010 | 2011 | 2012 | 2013 | 2014 | 2015 | 2016 | 2017 | Total |
|---|------|------|------|------|------|------|------|------|------|------|------|------|-------|
| Structural Survey | | 1 | | 1 | | | | | | 1 | 1 | | 4 |
| Automation in Construction | | | | | | | | 2 | 4 | 2 | | | 8 |
| ISPRS - International Archives of the Photogrammetry, Remote Sensing and Spatial Information Sciences | | | | | | | 1 | 5 | 1 | 3 | | 1 | 11 |
| Procedia Engineering | | | | | | | | | | 2 | 1 | 1 | 4 |
| Journal of Construction Engineering and Management | | | | | | | 1 | | | | | | 1 |
| Springer Berlin Heidelberg | | | | | | | | | | 1 | | | 1 |
| Journal of Cultural Heritage | | | | | | | | | | | 1 | | 1 |
| SCIRES-IT | | | | | | | | | | | 1 | | 1 |
| Journal of Professional Issues in Engineering Education and Practice | | | | | | 1 | | | | | | | 1 |
| Journal of Management Engineering | | | | | | | | | | 1 | | | 1 |
| Springer International Publishing | | | | | | | | | 1 | | | | 1 |
| International Journal of Architectural Heritage | | | | | | | | | | | | 1 | 1 |
| Survey Review | | | | | | | | | | | 1 | | 1 |
| Advanced Engineering Informatics | | | | | | | | | | 1 | | | 1 |
| Science China Technological Sciences | | | | | | | | | | | 1 | | 1 |
| Journal of Architectural Conservation | | | | | | | | | | 1 | | | 1 |
| Procedia Environmental Sciences | | | | | | | | | | | 1 | | 1 |
| Journal of Construction Engineering and Project Management | | | | | | | | | | 1 | | | 1 |
| Energy and Buildings | | | | | | | | | 1 | | | | 1 |
| International Journal of 3-D Information Modelling | | | | | | | | 1 | | | | | 1 |
| Computing in Science & Engineering | | | | | | | | 1 | | | | | 1 |
| Energy Procedia | | | | | | | | | | 1 | | | 1 |
| Built Environment Project and Asset Management | | | | | | | | | | 1 | | | 1 |
| The Open Construction and Building Technology Journal | | | | | | | | | 1 | | | | 1 |
| Journal of Cultural Heritage | | | | | | | | | | | | 1 | 1 |

| | | | | | | | | | | | |
|--|--|---|---|--|---|---|---|---|---|---|---|
| Visualization in Engineering | | | | | | | | | 1 | | 1 |
| Informes de la Construcción | | | | | | | 1 | | | | 1 |
| ASCE-Computing in Civil and Building Engineering | | | | | | | | | 1 | | 1 |
| GeoResources Zeitschrift | | | | | | | | | 1 | | 1 |
| International Journal of Sustainable Development and Planning | | | | | | | | | | 1 | 1 |
| White paper | | | | | | | | | | | |
| Autodesk | | | | | 1 | | | | 1 | | 2 |
| Leica Geosystems | | | | | | | | 1 | | | 1 |
| World Transit Research | | | | | | | | 1 | | | 1 |
| Web site Smarly.de | | | | | | | | 1 | | | 1 |
| Conference Proceedings | | | | | | | | | | | |
| Proceedings of CAA | | 1 | | | | | | | | | 1 |
| International Conference on Construction in Developing Countries | | | | | 1 | | | | | | 1 |
| IEEE Industry Applications Society Annual Meeting | | | | | 1 | | | | | | 1 |
| Third International Conference Remote Sensing Geoinformatics Environment | | | | | | | | | 1 | | 1 |
| Int. Work.Remote Sens. Disaster Management | | | | | | | | | 1 | | 1 |
| MATEC Web Conference | | | | | | | | | 1 | | 1 |
| International Conference on Quantitative Infrared Thermography | | | | | | 1 | | | | | 1 |
| Lecture Notes in Computer Science | | | | | | | | 2 | | | 2 |
| eWork and eBusiness in Architecture, Engineering and Construction - Proceedings of European Conference on Product and Process Modelling, ECPPM | | | | | | | | | 1 | 1 | 2 |
| International Conference on Virtual System & Multimedia (VSMM), IEEE | | | 1 | | | 2 | | | | 1 | 4 |
| Proceedings of CIB WT8 Conference | | | | | | | | | 1 | | 1 |
| DigitalCommons@University of Nebraska - Lincoln | | | | | | 1 | | | | | 1 |

| | | | | | | | | | | | | | |
|---|---|---|---|---|---|---|---|----|----|----|----|---|----|
| European Workshop on Structural Health Monitoring - EWSHM | | | | | | | 1 | | | | | | 1 |
| International Conference on Computing in Civil and Building Engineering | | | | | | | | | 1 | | | | 1 |
| International Symposium on Virtual Reality, Archaeology and Cultural Heritage | 1 | | | | | | | | | | | | 1 |
| Konferanse "Løfter Bæ-Næringen" | | | | | | | | | | 1 | | | 1 |
| WIT Transactions on The Built Environment | | | | | | | | | | 2 | | | 2 |
| Regulations | | | 1 | | | | | | 1 | 1 | | 1 | 4 |
| Books | | | | | | 1 | | | | | | 1 | 2 |
| Total per year | 1 | 2 | 2 | 1 | 2 | 4 | 6 | 10 | 16 | 23 | 13 | 6 | 87 |

Table 2.2-1 Distribution of papers reviewed. Source: author.

The occurrence of the keywords HBIM, H-BIM, HBIMM, BHIMM, BIM for existing buildings, Historic Building Information Modelling, Heritage BIM, CHIM (Cultural Heritage Information Management), CH modelling and Facility Management (FM) is measured. The bibliometric approach (Figure 2.2-1) has shown an increasing interest about the topic “BIM for existing buildings” in the last decade, mostly from 2013 to 2016. Obviously, the review about 2017 is incomplete, as papers have been written in half a year. Globally, the denomination “HBIM”, emerged in 2009, is less employed in titles and keywords than “BIM for existing buildings, structures and facilities”, revealing that Historic Building Information Modelling requires further development and investigations to result into a robust methodology, as concluded by Arayici et al., 2017 into their last work (Arayici et al., 2017).

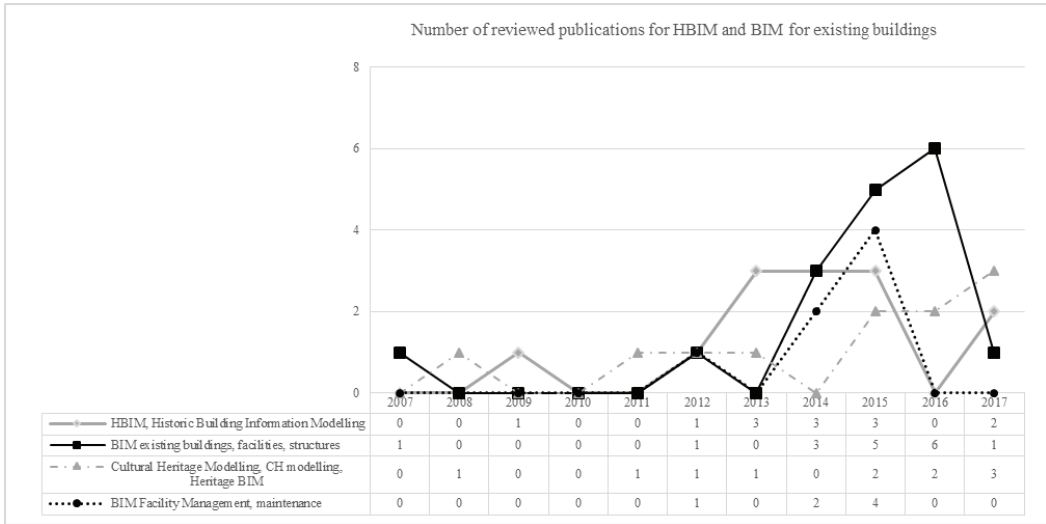

Figure 2.2-1 Trend of published papers and contributions in BIM for existing buildings, from 2007 to 2017. Source: author.

2.3 Critical analysis

Based on the selection of relevant papers, as reported in Section 2.2, specific methods and tools for HBIM model, diagnosis and performance analysis are illustrated in sub-sections 2.4. Nevertheless, a preliminary brief description of concepts, standards/protocols, methods and tools about BIM is reported in sub-section 2.3.1, in order to outline the general background and discuss some aspects in the specific field of existing buildings that will be beneficial to guide a new configuration of Diagnosis-Aided HBIMM via automating operations.

2.3.1 Information management and exchange tasks

The sector of FM (including refurbishment) is generally lacking adequate interoperable platforms and calls for a paradigm shift among the involved actors (Ilter and Ergen, 2015). The problems increase when the team is involved in the refurbishment of exist-

ing/historic buildings because the effectiveness of the decisions depends on the accuracy of the knowledge of the building and its components. Traditionally, professionals use different organisational schemes and archives to handle information, with consequent difficulty and time consumption for consultation that might result in incomplete documentation.

The solution is offered by the immediate access to a centralised BIM model that integrates all information; data analysis can be graphically displayed and inserted within internal or independent databases, the latter connected to BIM instruments via ODBC or programming automated tasks (Volk et al., 2014)(Iltter and Ergen, 2015).

2.3.2 Information classification and representation

The information requirements for “as-built” modelling of a historical building concern both technical information on building components and historical/analytical information (Pauwels et al., 2008). The first set of information relates to materials, construction techniques, performance, conservation conditions, settlements, and maintenance instructions.

The second type consists in intrinsic parametric relations between measurable data and intangible data about history, musical culture and traditions (Fai et al., 2011).

The use of BIM requires the identification of the Level of Development (LOD) and the Level of Detail (LoD) for the information in the model, with the purpose of limiting misunderstandings. The Level of Detail quantifies the details within building object, whereas the Level of Development is a degree of graphic and semantic information that can be reached for each defined objective, following the protocol of the minimum information content, its updating and the reliability of graphical content and information (‘Document E202 TM – 2008 Building Information Modeling Protocol Exhibit’, 2008)(Smarsly and Tauscher, 2016). According to the American Institute of Architects (AIA) definition and protocols (Eastman et al., 2011), the Level of Detail measures graphic accuracy and awareness of properties.

In refurbishment projects, the Level Of Development should not be lower than LOD 500, because BIM models must represent an “as-built” or “as-is” condition thus providing

a higher degree of completeness by a geometric survey, finalised and updated with all the necessary information for management and maintenance, aiming at a certain level of automation in semantic enrichment and analysis. The graphical representation of historic buildings for refurbishment might not be smaller than scale 1:100 to reach a reliable and detailed “as-built” model with LOD G, as defined by UNI (UNI/CT033, 2017). The data is collected within the database and the creation of relations among parameters allows connecting them when changed. However, when modelling architectural objects of existing buildings is the objective, understanding the level of accuracy of the geometrical parameterised objects is paramount, taking into account the complexity of the shapes. In addition, the project stage imposes fixing the information requirements of the specific LOD by defining simplifications or enrichments of the geometric models. The continuous digital flow in BIM requires the acceptance of a shared language for unique understanding and interoperability among the software products, which should classify tasks and information within a single team or networked companies. The language models used in BIM approach are exchange formats among applications, categorised in proprietary and open-source ones. Some researchers have conducted an analysis on Semantic Web technologies integrated with HBIM; the result is an ontological system for knowledge representation and management of decisions on interventions or functional activities of the architectural heritage (Del Giudice and Osello, 2013)(Cursi et al., 2015).

2.3.3 Information management standards and protocols

The efficient application of the BIM potential stands on the definition of the Information Management rules, depending on the association of actors involved in the refurbishment process: private or public owner, professionals and contractors. First of all, the work group must respect a strict organisation to achieve the defined objectives, without redundancy or contrasts; therefore responsibilities and duties are as-signed according to the hierarchical position and reciprocal relations. Subsequently, the group cooper-

ates to define the Information Requirements meeting the project objectives and the Information Exchange (ie) method to import and export data and information in and from the Information Model (PAS 1192-3, 2014). Facility Management (FM) activities are managed using Construction Operations Building information exchange (COBie), or CMMS (Computerised Maintenance Management System), EDMS (Electronic Document Management System) and BAS (Building Automation System) (Becerik-Gerber et al., 2011) com-plied through the involved parties or installed sensors, with specific roles and responsibilities, and providing maintenance information (Volk et al., 2014). The contents of the files are established by the Information Requirements (IR). The attributes inserted in this structure might be also mapped in XML and IFC format (BuildingSMARTAlliance, 2015). However, the Information Exchange (IE) COBie and its related Model View Definition (MVD) are partially adapted for inspections, monitoring and maintenance of existing buildings, chiefly historic buildings (Volk et al., 2014). In fact, COBie collects data related to the decomposition of spatial and technical information acquired throughout the design and construction, the environmental issues, the safety and the building operational phase for new buildings. The BIM model can operate as a single archive for consultation and query of such data stored within FM systems and computable by customised databases or automated task programming.

2.3.4 BIM services for knowledge sharing and reuse

An effective information management generates accurate documentation about existing buildings, containing requirements and criteria aiming at automating performance assessment and decision-making on the refurbishment. In this regard, the use of digital documents gives the opportunity to upgrade and expand the data, with savings of long-term resources. Therefore, different BIM services of knowledge sharing and reuse were analysed. A BIM model can function as a web database that documents the inherent attributes of the parametric architectural objects. Their inclusion in the shared object library allows knowledge of the tectonics of assets, materials, building components (Murphy et al., 2013)(Cheng et al., 2015); additional information related to intangible

data such as local culture and historical memories, as well as maintenance program. Moreover, a navigable timeline can also be created by introducing temporal parametric data to represent events and actions that occurred over time (Fai et al., 2011) and current decay situation. It is evident that the amount of information is enormous, and problems of data management in an extremely sized file can be solved with the BIM repository, in which building model is used as coordinating centre, synchronised to share data among different applications and databases. The BIM repository is a server system or a database that collects the entire set of objects data, useful to facilitate the information management. Its capabilities (queries, handover, updating and management) allow filtering only data related to the planning phase to be conducted (Eastman et al., 2011), thus limiting the data size and generating linear data flows.

Currently, further technologies are spreading for digital information about the historical and archaeological heritage (Forte et al., 2004)(Jiménez Fernández-Palacios et al., 2016): Virtual Reality (VR) and Augmented Reality (AR). A VR environment can be created with three-dimensional reconstructions by laser scans and photogrammetry (to represent the actual state), or navigable BIM models in order to present future/virtual scenarios. When used in refurbishment of the built heritage, VR also improves the visualization of representative data, with the possibility of interacting within the simulations (Forte et al., 2004)(Jiménez Fernández-Palacios et al., 2016)(Remondino and Niederoest, 2004)(Lee et al., 2016). The interactive activities with VR permit querying exterior and structural data, proper settings, internal relations, information, tags, etc. Experimental projects have been developed for storing information in freeze models of investigations and preliminary analysis on existing buildings, browsed as digital documentation through Virtual Reality technology. Such investigations could be further improved by remote visualization of detected and analysed decay patterns and pathologies; an ongoing approach in digitising and sharing information of the cultural heritage, above all with difficult accessibility, is managing diagnostic data through a touch less system for Augmented Reality (Polishape srl et al., 2014). The AR technology also allows the representation of the alternative scenarios of the project; the difference with the VR is that the user interacts - asking computer-generated data - on a real-world

scene (Cheng et al., 2015)(Chen et al., 2011)(Williams et al., 2015). The use of digital models implies the management of upgraded Big Data, causing difficulties while navigating the model. The online BIM repository could be connected to the AR environment via web service-oriented architecture (SOA) to create the so-called BIMcloud (Chi, 2013). Another technology for knowledge sharing and reuse in BIM are Radio Frequency Identification (RFID) and the Internet of Things. When Volk et al., 2014 (Volk et al., 2014) analysed the level of integration of RFID and BIM, open issues on difficult installation, limited interoperability, level of detail and automation of elaboration process for built asset management were identified. Despite this being an underdeveloped topic, some studies have been carried out. The employment of RFID devices has been investigated in a pilot project for Facility Management and Operation to connect BIM to non-value added tasks such as search, access and validation of information in maintenance records, specifications and operational manual, for time saving (Meadati et al., 2010). Generally, RFID tags are combined with laser scanner with the aim of creating complete 3D models of the built environment to be tracked during the construction phase, on waste and resource (materials, workers, etc.), as well as handover in the construction site (Valero et al., 2014). Recently, Zhang and Bai, 2015 (Zhang and Bai, 2015) developed an automated and graphical approach to structural condition monitoring based on RFID devices that communicate displacements to a BIM computing environment. The Internet of Things (IoT) works via cloud databases connected to BIM model of dynamic energy (Zhao et al., 2013) and structural monitoring, as well as team communication.

2.4 HBIM model, diagnosis and performance assessment

2.4.1 Geometric survey, augmented visual inspection and parametric models

The analysis of the current literature on BIM for existing buildings or HBIM (H-BIM) proves an increasing number of publications of parametric modelling starting from

three-dimensional reconstructions via reverse engineering methods and visual inspection techniques, thus combining traditional and innovative geometric surveys, as shown in Table 2.4-1. Since the first applications of BIM for existing buildings (Arayici, 2007)(Murphy et al., 2009), the generation of realistic BIM models was carried out combining prior available drawings and laser scanning techniques. Dore et al., 2012 (Dore and Murphy, 2012) proposed the generation of 3D cultural heritage models from laser scanning and photogrammetric acquisitions, due to their latest developments which provided some solutions to limitations in geometrical surveying.

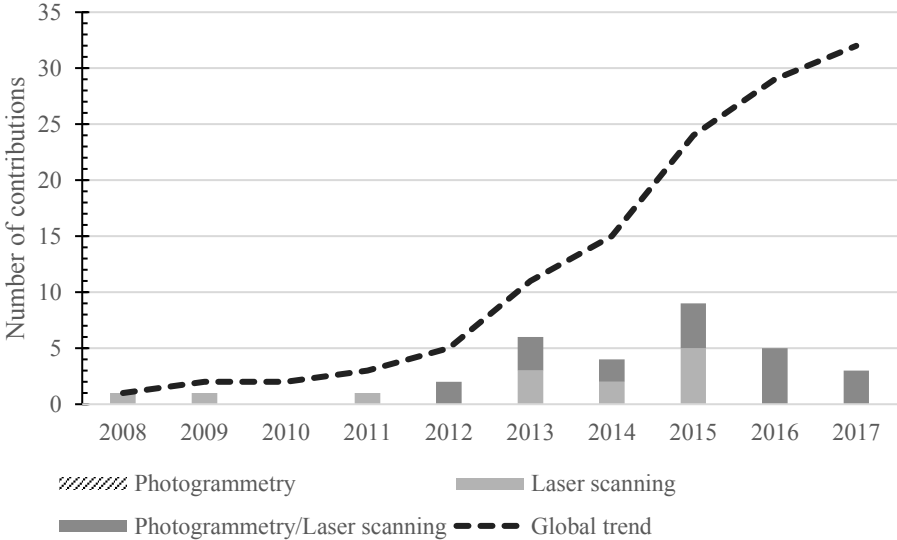

| | 2008 | 2009 | 2010 | 2011 | 2012 | 2013 | 2014 | 2015 | 2016 | 2017 |
|-------------------------------|------|------|------|------|------|------|------|------|------|------|
| Photogrammetry | | | | | | | | | | |
| Laser scanning | 1 | 1 | | 1 | | 3 | 2 | 5 | | |
| Photogrammetry/Laser scanning | | | | | 2 | 3 | 2 | 4 | 5 | 4 |
| Total=32 | 1 | 1 | 0 | 1 | 2 | 6 | 4 | 9 | 5 | 3 |

Table 2.4-1 Trend in parametric modelling from acquired point clouds in HBIM methodology. Source: author.

The first step is the acquisition of complex geometries as point clouds via laser scanning (LiDAR - Light Detection and Ranging) or photogrammetry/video-grammetry in terrestrial and aerial configurations respectively, for territorial and/or detail scale acquisitions. The required functionality of the BIM model influences the LoD, and subsequently, technical decisions about data capture, processing and BIM model creation (Volk et al., 2014). The 3D laser scanning belongs to the category of Active Reality Capture methods for acquiring discrete data, while photogrammetry is a Passive image-based alternative. According to survey objectives, the remote sensing is performed with equipment installed on space probes, satellites, and aircraft, Remotely Piloted Vehicles (RPVs) or Unmanned Aerial Vehicles (UAVs). Recently, remote sensing is less performed with conventional aerial platforms because of the widespread diffusion of UAVs applications, firstly applied in the military sector and then for civilian purposes (Vacanas et al., 2015). The devices installed on UAVs ensure the acquisition of inaccessible spaces because of the height (i.e. roofs) or restricted dimensions (Vacanas et al., 2015). In addition, the acquisition of the building elevations with satellite images - more suitable for land monitoring - would be affected by atmospheric phenomena and restriction of investigated areas because of the nearly parallel observation cone. Likewise, the use of terrestrial laser scanner or photogrammetric devices would not acquire parts of the building due to their short distance or presence of objects impeding the view (Adams et al., 2010).

In the latest investigations, research teams stretched out to combine LiDAR and photogrammetry for 3D BIM modelling to solve some critical factors. One is the detection of transparent, reflective or dark surfaces (Achille et al., 2012)(Volk et al., 2014), via photo-shots that scan surfaces with different light exposure and unfavourable optical properties. The other consists of intensive data processing and three-dimensional modelling of scanned point clouds in terms of expensive and powerful technical resources (equipment, hardware, software) and time-consumption in data management (Volk et al., 2014). Indeed, laser scans and point cloud processing require different tools than 3D photo-reconstruction. After registering each scan in the Project reference system, by means of the proprietary LiDAR software, they are managed and edited in specific

software tools for point cloud processing and modelling, such as 3DReshaper® or ReCap Pro®, as file *.pts, *.xyz, etc. The alignment of partial point clouds can be generated via ICP (Iterative Closest Point) algorithm (Quattrini et al., 2015)(López et al., 2017), or within HBIM plug-in prototype by Dore et al, 2012 (Dore and Murphy, 2012) which employs embedded scripting language to align segmented point clouds in their true geo-reference. On the other hand, the 3D photo-reconstruction uses the same tools for photo alignment and matching, point cloud generation, optimisation and 3D meshing. Some tools for photogrammetry solution are Photoscan Agisoft®, ReMake® and ReCap 360 Autodesk®.

The generation of point clouds from aligned and stitched image starts with the application of the Structure for Motion (SfM) algorithm within dedicated tools which estimate the three-dimensional environment from the two-dimensional image sequences that may be coupled with the local motion signals (Adams et al., 2010). Among other tools, ReMake is more user-friendly and easy to use, as it does not include the manual stitching correction property to assist the pattern-matching algorithms. This method permits the detection of common points within images to align and calculate the depth of the scene, setting a number of pixels with same colour and distance. The processing time from sparse to dense point clouds depends on the considered amount of points. The measurement errors, that can occur with photogrammetry, due to its function algorithm of image matching that is sensible to object movements, decrease by employing strict acquisition plans, professional equipment and accurate programs for photo-modelling (Siebert and Teizer, 2014). Each software product has different algorithms to neglect the background noise.

After checking the adequate alignment of scans and shoots with Cloud Compare software, computing the point cloud file by the RANSAC (RANdom SAmple Consensus) algorithm, the following step is the point cloud cleaning with the elimination of all the unusable parties. Before the actual BIM modelling, the representation of geometry and texture occurs in order to achieve a photo-realistic appearance, with the generation of 3D meshes and textures (*.obj) from optimised discrete-based or image-based data point clouds, forming a multi-triangulated surface. Nowadays, the tools for 3D photo-

reconstruction develop along with cloud computing to ensure heavy processing without a powerful machine (i.e. ReMake® and ReCap 360 Autodesk®). In fact, the available software tools archive the selected photos in the A360® storage drive, to be converted in 3D reconstructions by cloud-driven algorithms.

Some methods for generating 3D meshes from complex point clouds already exist. The most robust algorithms for 3D mesh reconstruction from point clouds are Poisson and Ball Pivoting surface reconstruction. Poisson surface reconstruction is used to match the best-fitting surface of a dense point cloud, estimating the most suitable shape to reduce deviation error among mesh and the best approximate shape and local curvature (Rodríguez-Moreno et al., 2016). Subsequently, optimised methods interpolate the missing points, ensuring a more detailed reconstructed surface. Dense point cloud is also the input for the surface reconstruction via the Ball-Pivoting algorithm, involving considerable time for processing and intensive use of the memory, two issues that might be solved with the integration of further processing algorithms (i.e. Digne algorithm and hole filling, varying ball radii).

The mesh noise may be reduced, firstly, via decimation that decreases the number of vertexes and increases the triangle size, then via densification, reducing the triangle size. This method is appropriate when the cloud contains a high number of points (Rodríguez-Moreno et al., 2016). After the first step, the filling of holes and the refinement of the mesh is performed via smoothing operations. However, the acquisitions of surfaces with decorative elements (laborious activity of smoothing surfaces) and complex geometries, especially in huge buildings, is still very time consuming.

Cho et al., 2015 (Cho et al., 2015) experimented with the generation of a BIM model - containing real geometrical and thermal information - starting from the 3D mesh, for energy simulation software products. The discretised mesh is created from the point clouds as acquired by a hybrid system consisting of thermo-camera, digital camera and laser scanner (laser, RGB-D and thermo-graphic cameras). The modelling of an entire building requires the elaboration of meshes for each single item as *.obj (Rodríguez-Moreno et al., 2016).

As BIM is an object-oriented methodology, the recognition and segmentation of each building component, within point clouds or meshes, represents the fundamental steps that can be performed manually, semi-automatically or automatically through robust algorithms of object recognition and point cloud/mesh segmentation (Volk et al., 2014). Among the most consolidated and approximated methods, some already analysed (Volk et al., 2014), researchers experimented with the plane segmentation algorithm for existing buildings with plane surfaces (Wang et al., 2015)(Liu, 2016), optimised by RANSAC algorithms against outliers and high plane-detection rates (Jung et al., 2014). Other algorithms, investigated for identifying and classifying objects within meshes or point clouds, consist of the colour recognition with spectral imaging (Amano and Lou, 2016) and shape recognition (Dore and Murphy, 2013).

Prizeman, 2015 (Prizeman, 2015) proposed some principles for a place recognition, detecting the construction type from historical photographs and data capture, in order to additionally consider the building components with curved shapes (such as curved and decorative ceilings). Indeed, the most relevant criticality is the automation in modelling complex and varied shapes, eventually decayed, from point clouds or meshes (Hichri et al., 2013).

Macher et al., 2014 (Macher et al., 2014) proposed to convert point clouds into meshes only for complex surfaces and high level of detail.

It is possible to extract geometric data and textures by the polygonal meshes obtained from photo-modelling and point clouds; both pieces of information are available for modelling the building and its parts within software tools for solid reconstruction and representation. The three-dimensional models elaborated with the SfM algorithms and laser scans can be used to measure dimensions, analyse materials and structural characteristics, as well as to locate decay patterns and pathologies from the photographic acquisition.

Reverse engineering results should be converted into parametric objects of building components in order to contain geometric, topological and semantic attributes. This flow switches from the reverse engineering process to the "point-to-BIM" or "scan-to-BIM" (Murphy et al., 2013). The modelling of parametric objects adds complexity to the

reconstruction of three-dimensional meshes, since software tools are not yet developed enough to automatically recognise and convert objects within meshes in BIM objects. Another method is the direct modelling of the parametric objects in Revit, by employing point clouds not converted in polygonal meshes thus avoiding loss in terms of details, data quality and accuracy (Oreni et al., 2014a)(Barazzetti et al., 2015)(Quattrini et al., 2015). The research works by Oreni et al, 2014 (Oreni et al., 2014a) and by Barazzetti et al., 2015 (Barazzetti et al., 2015) concern the generation of non-Uniform Rational Basis-Spline (NURBS) fitting with boundaries points of clouds. Quattrini et al., 2015 (Quattrini et al., 2015) followed this method to reduce number of steps, but they recognise that features for automatic extraction from point clouds is required within the available software products. This generates a challenge in simplifying the existing morphologies and employing ReCap as point cloud-processing engine. Therefore, it is possible to employ some add-ons, for instance “Scan to BIM®” or “Edge-wise®”, to support the modelling of architectural objects free shapes from point cloud to mesh after automatic recognition. In fact, such operation could be useful in cultural heritage modelling (Logothetis et al., 2017). These tools permit the direct conversion of elements with primitive shapes into parametric objects (walls, pipes, etc.).

The diagram of Figure 2.4-1 illustrates the level of automation from reverse engineering to BIM. The study has been carried out comparing contributions in which georeferencing automation, object recognition/segmentation, conversion from point clouds to BIM objects (point clouds-OBIM) and mesh to BIM objects (mesh-OBIM) are specified. The analysis involves 32 contributions presenting several case studies for HBIM from point clouds acquisition and processing. Some works do not declare the degree of automation or the performed methods. The automatic georeferencing of point clouds into BIM modelling tools is mostly carried out (18,8%) by GPS devices and geodetic grids during acquisitions. The object recognition and segmentation still succeed as semi-automatic process (6,3% vs 3,0% of direct scan-to-BIM tools), because customised algorithms are not widely implemented into available software tools and they are related to plane/primitive shapes, while historic buildings present complex geometries. The use of point clouds or meshes as input for parametric modelling (point cloud-OBIM and

mesh-OBIM) presents the same total frequency as manual operations (3,1%), semi-automatic occurrence is higher because the automation is considered by authors as a smaller number of steps, within the processing of almost plane shapes. Further investigations are needed for BIM generation of curved and decorated surfaces. Therefore, the most used technique is still the manual modelling of parametric objects using three-dimensional reconstructions as geometric reference (Oreni et al., 2014b). Recently, companies of BIM platforms have been collaborating with laser scanner manufacturers in order to speed up the conversion of point clouds into intelligent BIM models (Jacobs, 2014). Generally, complex and irregular geometries, accurately detected with laser scans or photogrammetry, are modelled using Boolean operations (extrusion and revolution), or through NURBS (Oreni et al., 2014b).

Figure 2.4-2 summarises the analysed processes from data acquisition to BIM.

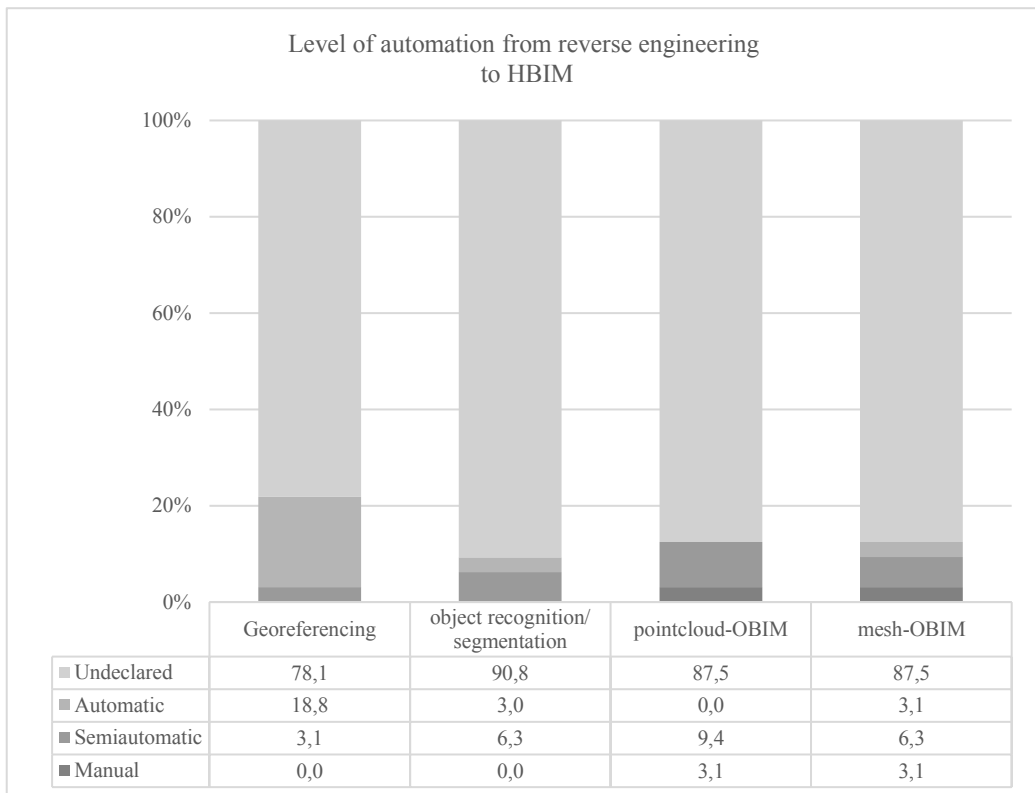

Figure 2.4-1 Level of automation from reverse engineering to HBIM. Source: author

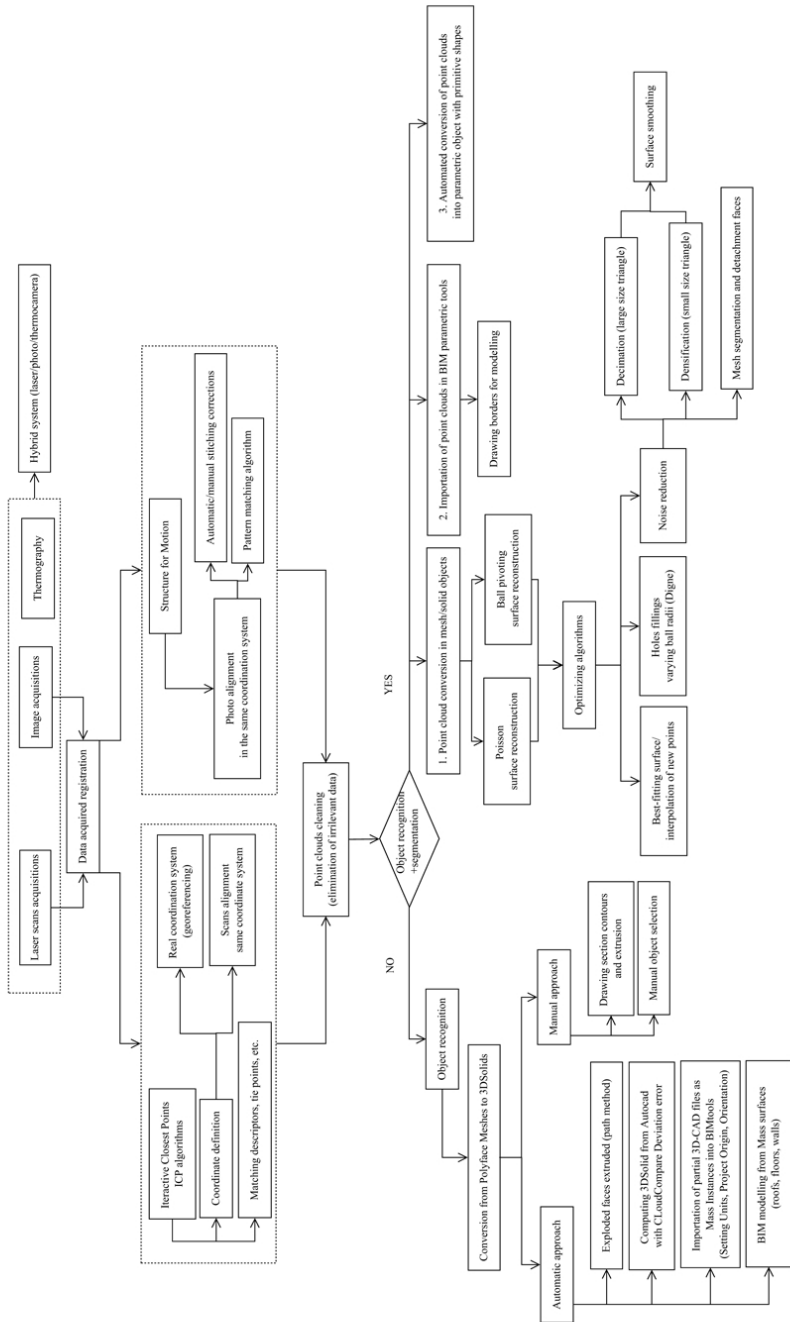

Figure 2.4-2 Processes from data acquisition to BIM. Source: author.

2.4.2 The implementation of diagnostics and monitoring data in BIM

The development of refurbishment interventions involves high levels of knowledge thorough pre-diagnosis of degradation phenomena of materials and components, and diagnosis of causes producing anomalies, settlements and pathologies, to ensure effective improvements and being less invasive.

Depending on the type of intervention, specific and accurate information is required whose reliability depends on matching outcomes of pre-diagnosis and outcomes of diagnostic activities and monitoring. The pre-diagnosis is composed of some sub-activities such as visual inspection, historical and archival research, and direct survey in order to gather preliminary data on geometrical and material characteristics, construction techniques, previous interventions, and to detect damages.

Such process is relevant in case of structural reinforcement and energy retrofitting. The objectives of the refurbishment are defined according to the identified residual performances of the building and its architectural, structural and technical components, with regard to variable environmental factors (indoor microclimate, outdoor climate, occupancy density, geological conditions, etc.).

The complexity of these tasks calls for in situ and laboratory tests to assess quality and deterioration of materials and components. All the gathered information might be inserted into the parametric objects to be consulted and queried for planning refurbishment and conservation measures of the Built Heritage (Oreni et al., 2013).

Therefore, the review of the latest scientific contributions and professional works about HBIM/BIM for existing building is herein further developed in order to outline the interest in introducing diagnostics and monitoring in BIM models, in order to give a contribution to support the decisions.

As Volk et al., 2014 (Volk et al., 2014) underlined, a complete assessment of existing buildings might be performed combining data capturing with diagnostic methods (ground penetrating radar, radiography, sonic tests, etc.) and installed tags. Thus, this literature review aims to detect gaps in condition assessment of existing buildings and

general trends in diagnostics and monitoring within BIM. The final goal is to overcome the gaps and address some improvements in the refurbishment sector.

2.4.2.1 Integrated applications of BIM with diagnostics and monitoring for energy retrofitting

The energy retrofit is defined by Khodeir, 2016 (Khodeir, 2016) as building upgrading with positive environmental performances and economic impacts in terms of reduced energy consumption and CO₂ emission.

The preliminary phase consists of assessing the existing building by collecting data and information about the material decay, identifying the residual performance and detecting building elements that necessitate upgrading.

In this perspective, a fundamental requirement for defining a robust methodology is the clarification of information/data and methods of acquisition, integration and reuse for energy simulations within the BIM methodology.

The most common approach for energy retrofit is simulating the current situation and the possible alternatives, trying to limit inaccuracies (Christodoulou et al., 2014). The current situation is generally modelled by assigning standardised thermal parameters to the building components. The use of such parameters, selected within software databases or from the literature, involves some estimation errors of the actual energy consumption of the building during the operational phase. Therefore, the measurements of current thermal performances (Cho et al., 2015) and subsequent calibration (Khaddaj and Srour, 2016) are relevant. Energy retrofits on existing buildings are generally performed with BIM tools, also to determine relative financial savings, in two phases that involve different information:

- the analysis of energy performance (Building Energy Performance Analysis);
- the control and monitoring of energy demand, combined with Building Energy Management Systems (BEMS) and Building Automation (BAS).

Among 19 analysed papers and works on energy retrofitting, seven of them illustrate acquisition methods of current building conditions (thermal parameters, environmental measurements) for energy simulation. Four research papers have been carried out in

other domains; however, diagnostics and monitoring are still not related to HBIM for energy retrofitting. Herein, an analysis of these methods, not yet thoroughly investigated on historic buildings, is proposed (Table 2.4-2) in order to identify possible solutions for Historic Building Information Modelling, when the degradation of the materials compromises the energy performances.

| | Existing buildings | BIM | HBIM - similar denominations - | BIM | Other applications | BIM |
|--|--------------------------------|-----|--------------------------------|-----|------------------------------|-----|
| Thermal properties diagnosis | (Lagüela et al., 2012) | • | | | - | |
| | (Cho et al., 2015) | • | | | | |
| | (Ham and Golparvar-Fard, 2015) | • | | | | |
| | (Alwan, 2016) | • | | | | |
| Monitoring humidity, temperature, energy consumption, etc. | (Woo and Menassa, 2014) | • | | | (Seeam et al., 2013) | • |
| | (Shi et al., 2015) | • | | | (Zhao et al., 2013) | |
| | (Nisbet et al., 2016) | • | | | (Marzouk and Abdelaty, 2014) | • |
| | | | | | (Simmhan et al., 2013) | |

Table 2.4-2 Analysis of literature on energy retrofitting and methods of thermal data/information capture for existing buildings, HBIM and other applications. Source: author.

The analysed scientific contributions, integrating Ilter and Erger, 2015 (Ilter and Ergen, 2015) and Cho et al., 2015 (Cho et al., 2015) works with further research papers, show new approaches (Figure 2.4-3) to optimise the results of energy simulations using: 1) measured parameters of humidity and temperature with wireless sensors networks (WSN) and 2) transmittance properties of building components evaluated with thermographic surveys. In this way, current thermal conditions and actual heat transfer capacity are captured and inserted into BIM as properties influenced by the deterioration of the materials (Cho et al., 2015).

The thermal transmittance values, calculated once the temperature variations on the surface are known as reported in thermic images, are mapped and associated with

parametric objects through importing/exporting of gbXML format - Green Building extensible mark-up language (Lagüela et al., 2012)(Cho et al., 2015), which also allows automatic updating of the BIM model. The use of measured parameters, rather than standardised ones, ensures greater reliability of the energy analysis with a reduction of inaccuracies (Ham and Golparvar-Fard, 2015).

On the other hand, the second approach to energy simulation exploits the Virtual Model Retrofit platform to manage the design decisions of energy retrofitting by integrating real-time environmental data (temperature, humidity and CO₂), faults detected in technological systems (HVAC), requests and perceptions from the occupants

In this procedure, the BIM model is used in the platform as a database to retrieve preliminary data to collect results for future energy simulations during the entire life cycle, facility management, and access to the smart grid (Woo and Menassa, 2014).

Alwan (2016) (Alwan, 2016) proposes a prototype protocol, Housing Building Refurbishment Plan (HBRP), which concerns the management of inputs within the BIM model, made available for maintenance and refurbishment of the existing housing stock. The Protocol affords for connecting the BIM model with an Asset Management tool, Construction Operations Building Information Exchange (COBie), so that the thermal images, captured during continuous monitoring, can be collected. The researcher recognises the potential of infrared thermography as a diagnostic tool for degradation of building components (lack or damage in insulation layers) involving heat loss; therefore, he confirms the need to integrate the results into the model, avoiding the analysis as independent and supplementary task.

The integration of BIM and BEM demonstrated to be useful in evaluation of the impacts on energy needs and costs for each defined refurbishment strategy (De Angelis et al., 2015). In a long term perspective, the adoption of BIM for BEM in existing buildings gives the opportunity to record the current situation, the maintenance history and the real performance, as outcomes of surveys and analysis into a BIM model (Di Giuda et al., 2015). BIM can also support operation and control of BEMS to ensure thermal comfort conditions and to optimise the performances of the technological systems (Seeam et al., 2013)(Shi et al., 2015), by activating Building Automation (BA) devices

installed. In BEMS, the automatic processes of acquisition, comparison and analysis of real-time energy data are based on the use of WNS, which has recently become smart through the Internet of Things. For instance, the Cyber Physical Systems (CPS) are used to connect the physical environment in software and hardware platforms through sensor networks to support the decisions (Zhao et al., 2013), in order to reduce energy consumptions and CO2 emissions. The information captured in real time (temperature, humidity, etc.) appear in the BIM model (Marzouk and Abdelaty, 2014). The cloud-based platforms manage the distribution of the energy resources at the urban scale, within a smart grid (Simmhan et al., 2013).

Another open issue regards the possibility to import the automatically extracted building elements from the point cloud, into the energy simulation software, as analytic models in order to reduce time in the modelling process, as well as to improve data accuracy and integrity. In addition, a general method of object recognition and extraction for as-built modelling is needed, including different types of existing building technologies (Wang et al., 2015).

This information could be utilised as criteria and sub-criteria of a multi-criteria and multi-agent analysis or inputs in deep learning⁴ algorithms for decision-making support of the design alternatives.

In this direction, sustainability properties and energy performance parameters might be employed to assess the best solutions and interventions for building redevelopment (or refurbishment). Pavlovskis et al., 2017 (Pavlovskis et al., 2017) introduced the energy efficiency, by energy category, as environmental criterion within a Multiple Criteria Decision Making (MCDM) approach.

Zainudin et al., 2016 (Zainudin et al., 2016) utilised the BIM methodology for assessing the Adaptive Reuse Project of a demountable Traditional Malay House (TMH) by the Leadership in Energy and Environmental Design (LEED) guidelines and the Malaysia's

⁴ Deep Learning is a new research topic of Machine Learning with the aim of moving towards the Artificial Intelligence. It employs multi-layered artificial neural networks to deliver state-of-the-art accuracy in tasks such as object detection, speech recognition, language translation and visual recognition (Lecun et al., 2015).

Green Building Index (GBI) rating assessment. This consists of evaluating building orientation and daylight performance by simulations in Autodesk Green Building Studio, taking into account some categories such as sustainable sites, water efficiency, energy and atmosphere, materials and resources, indoor environmental quality. The considered parameters for daylight evaluation include floor area, window area, window geometry, visible transmittance, known materials, and window height. The purpose is the selection of the alternative with the highest rating considering energy costs, water needs, energy consumptions and use of renewable energy, reduced use of materials, preferring recycled ones, reduced carbon footprint and waste, managing site and logistics.

Information exchange succeeds via connection of BIM model and external databases with energy simulation applications. Table 2.4-3 illustrates some reviewed works that develop workflows within DB, clarifying DB application, case study, AEC phase for adoption and functions. This analysis includes papers not related to HBIM topics.

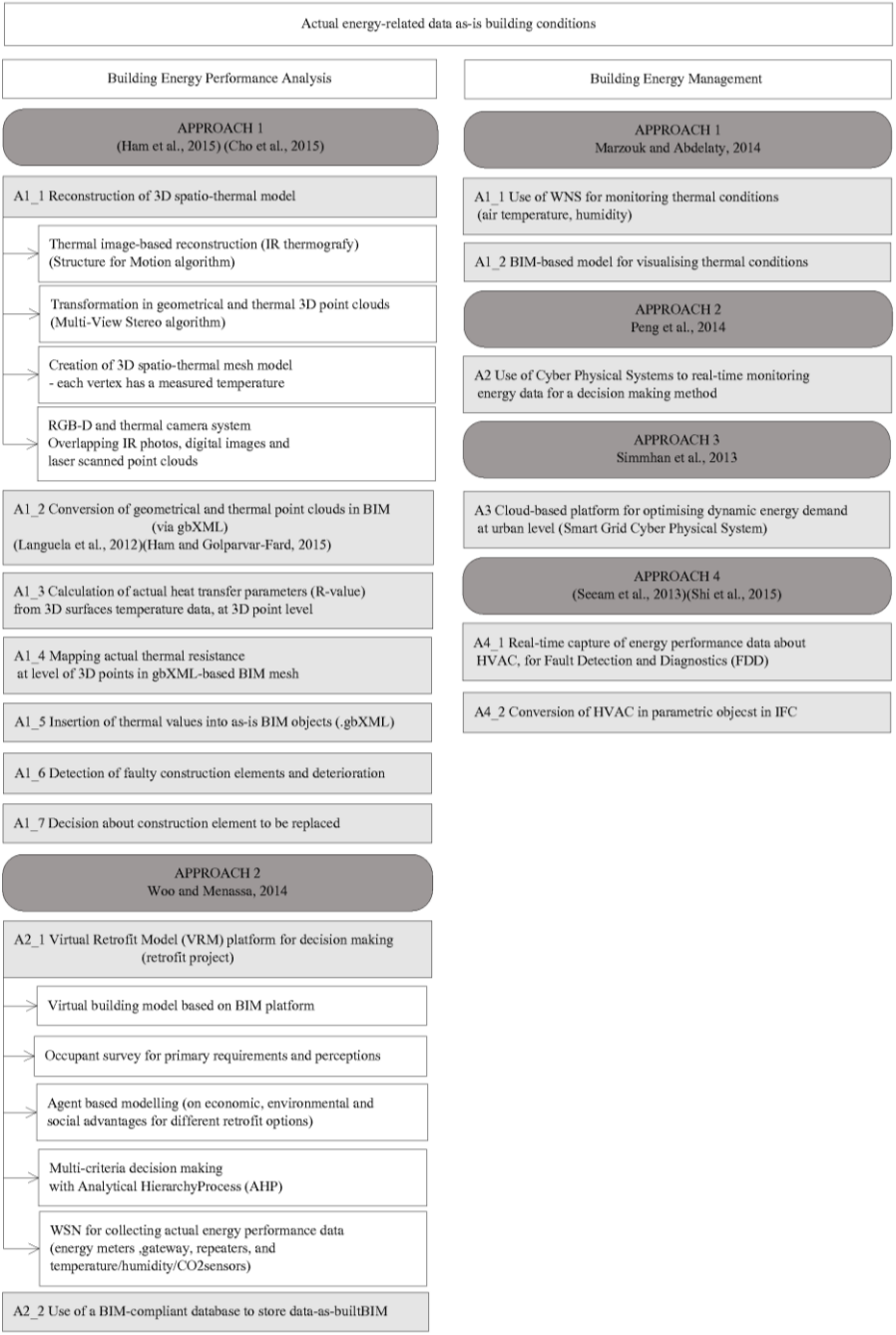

Figure 2.4-3 New approaches for optimising energy simulations. Source: author.

| Authors | External Database | Case Studies | Phase | Functions |
|--------------------------------|---|---|---|--|
| (Kassem et al., 2015) | Microsoft Excel® | Northumbria University's city campus, UK | Refurbishment Maintenance Operation Asbestos removal | Space information (i.e. for room finding), integrated asbestos register, emergency equipment, escape routes, accessibility and essential maintenance, fault reporting, development and refurbishment, option generation, and assessment of building performance. |
| (Woo and Menassa, 2014) | Microsoft Access® | TIC building with solid masonry structure (1913), Wisconsin County Research Park (USA) | Energy retrofit | Transfer of up-to-date energy information from wireless sensor network into the Revit model using DB Link, a Revit API (Application Programming Interface). |
| (Sampaio and Simões, 2014) | Microsoft Access® | Small fraction of real estate development in Cascais, near Lisbon, Portugal | Maintenance | Inspection sheet: anomalies, causes, solutions and repair methodology detected on building components. It is connected to a User Interface created with Visual Basic. |
| (Ham and Golparvar-Fard, 2015) | Updated databases of actual thermal properties | Existing residential building (early 1980s); this approach can be used for new buildings | Building energy retrofit | Recording actual thermal properties of BIM elements to estimate the time series trend of thermal characteristics of building elements and their impact on the energy load. |
| (Murphy et al., 2013) | Users database storage created with Ruby® on Rails and Javascript | European classical architecture components and parts | Conservation, restoration HBIM | Uploading of ortho-image or segmented point cloud. |
| (Dong et al., 2014) | PostgreSQL® Database connected with the BACnet (Building Automation and Control networks) module in BCVTB (Building Control Virtual Test Bed) | Recruit barracks, BIM enabled information infrastructure for FDD (Fault Diagnostic and Detection) | Operation Building Energy Management | Handover and storage of dynamic information (flows, humidity, temperature, etc.) acquired in real-time by physical sensors within a Building Energy Management Systems (BEMS) in building, and management of static information about building geometry, envelope's thermal performance, HVAC equipment properties, building occupancy, etc. |
| (Gerrish et al., 2015) | SQL server | BIM as lifecycle building performance management tool | In-Use performance | Storage of historical time-series performance data about energy consumption, air temperatures and equipment performance. |
| (Wang and Barryman, 2011) | BEDEC database (Life Cycle Assessment LCA) | An university campus | All | Storage of embodied energy and CO2 emissions associated with building materials, considering raw materials supply, transport and manufacturing. |

Table 2.4-3 BIM model and external databases as tools for energy simulation applications. Source: author.

2.4.2.2 Integrated applications of BIM with diagnostics and monitoring for structural reinforcement

Further analysis involves risk assessment and detection of criticalities/vulnerabilities of the structural behaviour for accurate projects of conservation and reinforcement. This phase consists of planning and executing the diagnosis, which generally includes in-situ inspections, laboratory tests, and structural (static and dynamic) health monitoring, even though control of environmental factors (temperature and humidity) affecting the building response.

Firstly, in situ investigations consist in visual inspection, whose results might be recorded mapping anomalies, deformations, cracks, pathologies and humidity patterns. A method for decay mapping consists of linking CAD drawings or views (Quattrini et al., 2017)(Rodríguez-Moreno et al., 2016) as 2D lines and textures within objects undergoing obsolescence and settlements with the consequence of losing the three-dimensional geometry and creating time consuming workflows to report them in each view. In recent years, preliminary in situ investigations have benefitted from the use of visual data for diagnostics and monitoring of buildings and infrastructures. The visual data is similarly acquired by photo-cameras also installed on UAV systems. These techniques allow monitoring deformations and cracks (Ham et al., 2016). In fact, the combination of digital images and point clouds can contribute to the semantic enrichment - manual, semi-automatic, or automatic – of three-dimensional models, including geometric data, visual survey of the conditions and connections among building components.

Ham et al. 2016 (Ham et al., 2016) have been trying to improve the modelling techniques for a complete "as-built" and "as-damaged" information model. Their research highlights the possibility of generating a three-dimensional map of buildings damaged by earthquakes by acquisitions by RGB-D sensors and 3D rotating scanners (Kassem et al., 2015)(Wefelscheid et al., 2012). In addition, images can be used to identify and locate crack patterns on elevations (Eschmann et al., 2013). The same techniques have been used to evaluate the structural damage of infrastructures (Ham et al., 2016). Ye et al. 2014 (Ye et al., 2014) have developed a machine learning process to classify

damaged buildings based on properties recognised by images. Despite evident potentialities, these activities have not yet been integrated into the BIM methodology in a complete and effective way. The next step is performing in situ tests, after accurate planning. For this purpose, papers on management of structural/technical diagnostic tests and monitoring within BIM approach have been studied, considering the investigation of existing buildings and infrastructure fields (Table 2.4-4).

| Diagnostics | Objectives | Existing Building | Infrastructure | General application | Open issue | Observations |
|--|---|----------------------------|------------------|-----------------------|--|---|
| Radar techniques | Detecting and modelling pipework below road surfaces, with information on layout and position | - | (Haugbotn, 2015) | - | Uncertainties in interpreting results | Aggregation of multiple types of data from different sources within a single reference model generated into BIM environment for accurate and rapid investigation |
| | Damage survey and diagnostic investigation for Building Condition Assessment | (Bruno and Fatiguso, 2018) | - | - | Sharing information about diagnostic survey in a unique model | Data sharing via: 1. database connections to the DBMS (DataBase Management System), employing the Revit BIM model as master of data source. 2. web services and cloud-based BIM applications, together with VR and AR |
| Semi-destructive and non-destructive tests (thermographic inspection, flat jack, core) | Material-constructive characterization | (Crespi et al., 2015) | - | - | Missing explanation of information exchange from Building Condition Assessment to FEM (Finite Elements Model) | Employment of investigations supports testing model reliability, with calibration of hypotheses |
| Monitoring | Objectives | Existing Building | Infrastructure | General application | Open issue | Observations |
| Structural Health and Safety Monitoring via RFID BT | Displacements and alarms | - | - | (Zhang and Bai, 2015) | Development of method for other instrumentation, also with direct contact, for structural deformation monitoring | BIM as an ideal 4D graphical computing environment for Structural Health Monitoring (SHM) and management considering amounts of sensor data |

| | | | | | | |
|--|--|--------------------|------------------------------|---|---|--|
| Structural Health and Safety monitoring with e.g. LVDTs, inclinometers and strain gauges | Progressive displacements in structural elements | (Rio et al., 2013) | - | - | - Required specific IFC - Acquisition, storage and processing of Big Data with high size | IFC extension needed, for example including new IfcSensor-Type |
| | | - | (Smarsly and Tauscher, 2016) | - | Limited interoperability | |

Table 2.4-4 Management of diagnostic tests and monitoring within BIM approach. Source: author.

Figure 2.4-4 presents five publications on diagnostics and monitoring in BIM for structural refurbishment of existing buildings, rehabilitation of infrastructures and general applications, from 2013 to 2016.

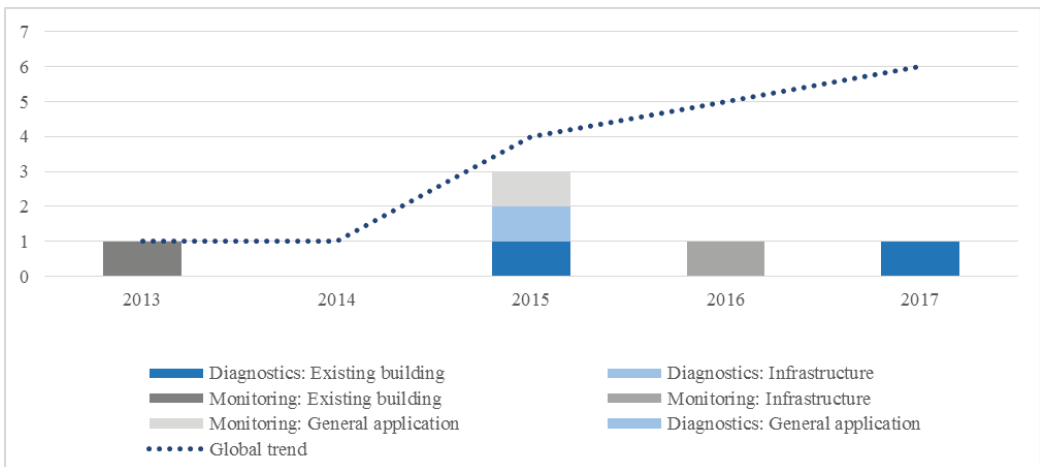

Figure 2.4-4 Trends in diagnostics and monitoring in BIM for refurbishment of existing building, rehabilitation of infrastructures and general applications. Source: author.

The analysis shows an increasing research interest in diagnostic and monitoring for structural reinforcement in BIM. However, it should be noticed that the topics are still underdeveloped in the refurbishment domain; actually, among 6 contributions, out of 87 reviewed papers, none is applied within the HBIM methodology.

Nevertheless, as tested in the infrastructure domain, BIM demonstrated great capability in collecting a variety of data, from different sources and analyses (Díaz and Baier, 2016).

There is an analogy between rehabilitation projects of road networks and refurbishment of the built heritage, namely the assessment of the existing conditions before the interventions; this assumption explains why the infrastructure field has been considered. In fact, in both cases, the design should take into account constraints from the morphology of the existing structures and spaces, as well as the regulatory requirements. Some northern European companies (Vianova, Norway and Plowman Craven, UK), experts in onsite measurements, have already undertaken some procedures to digitalise the properties detected with radar techniques, processed with proprietary software tools and comprised in CAD and BIM tools. In particular, the Norwegian buildingSMART chapter works with various infrastructure construction companies on the development of parametric modelling including the results of radar surveys (Haugbotn, 2015). In this way, it is possible to model the pipework below the road surfaces according to significant information on layout and position.

Among the research works related to BIM to evaluate the structural behaviour, Crespi et al., 2015 (Crespi et al., 2015) marginally address the topic “diagnostics” (semi-destructive and non-destructive tests) for material-constructional characterisation of Castel Masegra (Sondrio, Italy) before performing the structural analysis by the Finite Elements Model (FEM). The thermal images have revealed masonry degradation by monitoring surface temperature and humidity in areas, otherwise inaccessible. Additionally, the semi-destructive tests with single and double jacks have been performed to estimate the masonry stress and the actual stiffness values.

Moreover, the masonry stratigraphy and thickness, and the typology of the foundations have been identified by local coring. The thickness of the vaults was evaluated by removing some portions of the finishing layers. However, they do not illustrate the methods of codifying, inserting, using and managing the diagnostic information (values of logged parameters, installation plan of the equipment, images, diagrams, comments), thus without recommending a protocol instructions.

Instead, Bruno and Fatiguso (2018) (Bruno and Fatiguso, 2018) proposed a method to share and reuse knowledge acquired through archival analysis, damage survey and diagnostic investigation and the formalisation of the Information Requirements as input

in BIM model. This method consists of the attachment of diagnostic information on equipment description, survey process, images, videos, comments, etc. of performed radar acquisitions and borescopy. This data is manually recorded into the model as attributes within parametric objects of architectural components and diagnostic profiles. The detected criticality concerns sharing information on diagnostic survey in a unique model in each refurbishment step, due to the large size of the model itself and the difficulty in handling several data sources. In this regard, the employment of databases connected to the BIM model through the DataBase Management System (DBMS) could represent an effective solution. An alternative one consists of developing web services and cloud-based BIM applications, together with VR and AR for BIM operative employment in construction site.

With regard to the data digitisation and management by static structural monitoring systems (e.g. Linear Variable Displacement Transducer (LVDTs), inclinometers and strain gauges), Rio et al., 2013 (Rio et al., 2013) have proposed a procedure on the development of a digital three-dimensional model of a real instrumented building, using the IFC standard. The preliminary study has highlighted the lack of structural kinematic sensors into the reference class `IfcSensorType`, within the IFC 2×4 RC2 standard.

The procedure involves the creation of a generic custom Property Set (in line with the IFC template) to hold the attributes of the sensors for structural monitoring. These attributes include name, function, properties, materials, openings, composition, representation and relationship parameters, frequency set point, temperature set point, date and time of acquisition, type of relationship between sensor and relative building component. However, the inclusion of a new `IfcSensor-Type` as IFC instances is needed for improved information management and risk mitigation. On the other hand, the issues connected to the acquisition of Big Data, by the monitoring activity, relate to the data storage and process within an information system. The management of data - continuously collected and updating - can be critical due to the size of the processed files. In addition, the person in charge of data collection and storage may not agree to share it. These two questions can be resolved by approving the maintenance of separate Structural Health Monitoring (SHM) acquisitions by the central digital model, thus sustaining

the control of the activities under the liability of the technicians. Consequently, an independent specific model is linked to the central digital model, in the form of programmed database, using the IFC standard. This approach belongs to intelligent structural health monitoring systems if sensors with internal capacities of data processing and analysis are used. When the information refers to SHM systems and implements monitoring techniques, it is called "monitoring-related information". A semantic conceptual model prototype was pro-posed on intelligent monitoring of civil infrastructures (Smarsly and Tauscher, 2016), a solution that could also be developed to monitor existing building. In the research work by Zhang and Bai, 2015 (Zhang and Bai, 2015), the connection of RFID tag-based breakage-triggered (BT) strain sensor and corresponding structural element in BIM allowed detecting the structural damage conditions whenever the recorded values exceeded some pre-set strain thresholds for contactless scanning of structural deformation conditions. The issue generated by IFC on loss of data fidelity has been solved by connecting BIM/FEM software and sensors via a Database Server and a BIM for SHM portal, enabled to alert engineers and decision makers about damaged elements. Table 2.4-5 illustrates some case studies carried out connecting BIM tools and external databases for infrastructural monitoring; these methods could be effectively implemented in SHM in historic buildings showing static and seismic criticalities.

| Authors | External Database | Case Studies | Phase | Functions |
|----------------------------|---|------------------------------------|--|---|
| (Jeong et al., n.d.) | NoSQL (Not Only SQL), MongoDB® for querying | Yeongjong Bridge in Incheon, Korea | Management, maintenance and inspection | Management of bridge structural health monitoring data in a Bridge Information Modelling (BrIM). |
| (Sternal and Dragos, 2014) | Reference database | A laboratory test structure | Maintenance Operation | Recording autoregressive models coefficients for structural assessment obtained from processing time series of newly collected accelerations. |
| (Zhang and Bai, 2015) | External database in the ODBC (Open Database Connectivity) format | A laboratory test structure | - | Custom defined shared parameters "RFID tag" and "damage flag", recording structural deformation condition. |

Table 2.4-5 Case studies carried out connecting BIM tools and external database for monitoring infrastructure. Source: (Bruno et. al, 2018).

2.5 Gaps in knowledge and future developments in HBIM for performance assessment

2.5.1 Open issues

2.5.1.1 Geometrical survey, augmented visual inspection and parametric models

The identified gaps in knowledge in this section on geometrical survey and augmented visual inspection for parametric modelling regard:

- i) High number of steps from point cloud, mesh to 3D solid and BIM parameterisation, when working on complex shapes. They require an import of the converted files in diverse software products and a combination of several methods according to the morphology of existing building;
- ii) Incompatibility of current software products with the automatic generation of parametric objects from point cloud/mesh for irregular building components and decorations;
- iii) Difficult recognition and segmentation of building components with curved and complex shapes (such as curved and decorative ceilings) within point cloud/mesh;
- iv) Partially realistic BIM models when a complex parameterisation is required for heterogeneous geometries and for decorated curved surface (i.e. frescoes on vaults).
- v) The most significant gap in knowledge, connected with some of the above-mentioned issues, consists of the low development of algorithms for automatic recognition and conversion in parametric objects (solved with primitive geometries, as currently feasible). After recognition and segmentation, the automation of BIM modelling from point clouds or meshes of complex building components, with varied shapes eventually decayed, can contribute to also accomplishing the gaps as in i), ii), iii). Another possible solution, proposed by some authors (Murphy et al., 2013)(Rodríguez-Moreno

et al., 2016), could be the dissemination of a library for existing buildings. It should be observed that such solution could be effective when modelling architectural building typologies (i.e. churches, castles, etc.) belonging in the same historic period. The case is different when considering historic aggregates of cities, mostly built by the owners - following personal requirements, rather than current constructive techniques - or transformed artefacts, as the HBIM library does not represent the solution because it imposes a certain level of standardisation.

- vi) The gap in knowledge iv), partially solved supporting BIM models with 3D realistic reconstructions of Computer Vision, could find a full resolution if new software applications were to be developed to configure the parameterisation and semantic enrichment directly in the textured reconstruction (photo-reconstruction and high resolution meshes from laser scanning). In this approach, the creation of three-dimensional photo-models or meshes from point clouds and photos could include the geo-metric measurements, the appearance with further information, such as reports on the performance assessment, as well as comments on causes and effects of pathologies, settlements and previous interventions.

2.5.1.2 Integrated applications of BIM with diagnostics and monitoring for energy retrofitting

Some of the identified gaps in knowledge on integrated applications of BIM with diagnostics and monitoring for energy retrofitting are still the ones identified by Ilter and Erger (2015)(Ilter and Ergen, 2015):

- i) Low level of development of effective hybrid systems made up of digital cameras, thermal imaging cameras and laser scanners for survey of complex buildings, beyond the inner spaces;
- ii) Lack of interoperability among BIM modelling tools which do not support the gbXML format;

- iii) Need for adequate BIM tools to model any geometry for energy simulation and decision support, so that the gbXML schema would not lose thermal data, even the measured data;
- iv) Need for techniques that are able to isolate, within the thermal images, only data on building components to be investigated, although not accessible;
- v) Need for methods and strategies to retrieve diagnostic data for accurate and complete results (Cho et al., 2015).

Further open issues are related to:

- vi) Time-consuming approaches for mapping properties and building components;
- vii) Need for energy analysis in dynamic (real) heat transfer mode, and not only in static (ideal) mode;
- viii) Required real-time updating of energy performances and involved parameters for adaptive solutions.

Among these open issues, iv) again results from the difficulty in recognition and segmentation of building components when working on laser scanned or photo-acquired point cloud/mesh (Section 4). The loss of properties due to the handover of gbXML in energy simulation software - with limitation in interoperability - could be solved by utilising database files, in which any building component is identified. Mapping them into the energy application via programming scripts for automatic connections and exchanging lists of material and current thermal data (i.e. employing Dynamo® Autodesk as graphical interface programming, or macros) could stream-line energy simulations. The synchronisation of continuous measurements and monitoring with BIM models, for communication and activation of adaptive solutions according to the environmental conditions, is a common issue. This could find accomplishment in experimenting with SCADA (Supervisory Control and Data Acquisition) solutions, such as RFID and the Internet of Things (IoT) with communication via cloud databases connected to the BIM model. The energy analysis in dynamic (real) heat transfer mode could be solved with

the above-cited methods. However, a Decision Support System could be useful to create a multi-criteria evaluation of the project scenarios.

Indeed, the involved parameters could be utilised in multi-criteria and multi-agent analysis, to calculate benchmarks and key performance indicators, or as inputs in deep learning algorithms in decision-making support of the design alternatives. For instance, the analysis of indexes could provide global and local views of building energy performances via dashboards or maps, in order to track the energy consumptions, for sustainable retrofitting and operation.

2.5.1.3 Integrated applications of BIM with diagnostics and monitoring for structural reinforcement

The gaps in knowledge are listed below:

- i) Low level of integration of diagnostic tests in the HBIM approach for material/constructional characterisation, performance assessment and structural monitoring;
- ii) Scarce employment of 3D laser scans or photogrammetric techniques, integrated in the HBIM approach, for augmented visual inspection and monitoring of progression of decay and cracks with the general scope of semantic enrichment over time;
- iii) Pathologies, decay and settlements still mapped in 2D views, with a laborious method that causes a loss of real geometry and semantic information;
- iv) Incomplete IFC standards for monitoring.

The complete diagnosis of current building conditions is a relevant stage in planning refurbishment of existing building, in order to eliminate risks and safeguard the historic memory. In this scenario, the above identified four gaps have to find a solution, above all because this is the domain less investigated in the HBIM approach.

The aspects ii) and iii) are connected to the gap in knowledge as defined in sub-section 2.5.1.1. The recognition of pathologies and cracks within the 3D textured model could

represent a key future development. Undeniably, the identification of degradation phenomena, directly in 3D reconstruction, can reduce time of drawing in 2D views, keep real appearance, 3D geometry and real extension of decay. This gap could be solved by integration of algorithms of deep learning (convolutional neural networks) for image recognition, after training applications to identify the targets. The gap related to scarce inclusion of diagnostic tests in HBIM can be solved by proposing some guidelines for acquisition and use of information acquired toward the refurbishment actions. This can occur in the view of codifying the performance requirements within a system oriented to 1) automatic diagnosis of performances by comparison of data and information from several sources, 2) generation of criteria for decision-making, 3) driven-decision on compatible interventions. For this purpose the available methods could include artificial intelligence technologies (neural networks, expert systems, etc.).

For instance, some experimentations should focus on the definition of guideline for the integration of:

1. Preliminary in situ investigations to evaluate internal stratigraphy, integrity of structural elements and presence of damage and vulnerabilities:
 - a. Photogrammetric and topographic survey to detect deformations and out of plumbs;
 - b. Radar tests and video-endoscopy to detect structural elements (e.g. vault stratigraphy, presence of voids and cavities, presence of reinforcement interventions);
 - c. Sonic and ultrasonic tests to determine the composition of structural elements (monolithic elements, multiple layers), consistency through the estimation of the sonic wave's propagation speed (presence of cracks and internal cavities);
2. Test of environmental vibration and dynamic identification to determine the modal parameters (frequencies and modal shapes), to interpret the dynamic building response;
3. Laboratory tests on samples of masonry, not extracted from the structure but characterised by similar properties:

- a. axial compression test (monotonic and cyclic type);
4. Evaluation of health and safety status of the structures through Finite Element analysis.

Another issue is getting the data easily and operatively during the diagnosis and execution phases; a solution proposed is employing user-friendly operative methods for consultation of diagnostic data via Virtual Reality and Augmented Reality. Certainly, remote visualization of detected and analysed decay patterns and pathologies is an ongoing approach in digitising and sharing information on the cultural heritage, above all with difficult accessibility, for managing diagnostic data through a touch less system for Augmented Reality (Polishape srl et al., 2014).

However, these technologies do not yet experiment with methods of codifying, inserting, using and managing the diagnostic information (values of logged parameters, installation plan of equipment, images, diagrams, and comments).

Further issues connected to the acquisition of Big Data, by monitoring activity, relate to data storage and process in an information system. The management of data - continuously collected and updated - can be critical due to the size of the processed files. A semantic conceptual model prototype was proposed for intelligent monitoring of civil infrastructures (Smarsly and Tauscher, 2016), a solution that could also be developed to monitor existing building.

Additional research development should experiment with visual recognition using convolutional neural networks (i.e. Watson by IBM®) combined with change detection algorithms within images (radargrams and thermograms) and photos in order to discover layers and presence of voids.

Another potential function of integrating BIM with diagnostics and monitoring in an automated DA-HBIMM framework would be the analysis of structural vulnerabilities, the calculation and mapping of defect condition ratings within a BIM platform as Decision Support System.

A general line of research consists of developing deep learning algorithms for diagnosis of pathologies and settlements, based on acquired knowledge, taking the progress of

expert systems and artificial neural networks in medicine as starting points for automatic evaluation of disease symptoms.

3 A METHODOLOGICAL APPROACH FOR IMPLEMENTING PERFORMANCE ASSESSMENT IN HBIM FOR HISTORICAL ASSETS (DA-HBIMM)

3.1 Toward Diagnosis-aided Historic Building Information Modelling

The analysis of the state-of-the-art revealed that improving the management of knowledge for diagnosis and performance assessment is a key point within a complete and integrated process for refurbishment. The method of knowledge management for diagnosis may rely on the solution of current criticalities that occur during the projects and the operation of buildings. These issues originate from the difficulty of dealing with fragmented data and information due to the scarcity and problematic availability of historical documentation, the inefficient collaboration of actors involved in certain projects and correlation of the data and information derived from several channels for finding the real causes of damage and low performances. These circumstances may lead to the selection and execution of incoherent intervention, in the sense of expensive and pejorative actions that can produce the increase of the current risks or the onset of further damages and building pathologies.

The processes and tools developed for digital representing and sharing a built object can effectively facilitate and support decision in the entire AEC sector. Specifically, the investigations about the HBIM approach is an ongoing frontier research characterized by a rapid progression, but it still needs to include methods and tools to support professionals in the automatic parametric modelling and in the qualification and assessment of the building residual performances, in terms of structural failures, losses of

comfort (thermal, acoustic, lighting) and energy efficiency. Consequently, this research is the result of three years of work organized in order to configure a methodology for solving these issues; a methodology that has been evolving as fast as other research results have been published in the field of HBIM, determining the requirement of overcoming the residual gaps in knowledge.

The proposed methodology Diagnosis-Aided Historic Building Information Modelling and Management (DA-HBIMM) follows a framework and accomplishes two sequential tasks:

- i. testing how existing BIM processes and software products can manage the data and information provided by diagnostic tests and monitoring in order to accurately and correctly aid the diagnosis phase, ensuring interoperable, shared and integrated data flows;
- ii. proposing and testing innovative approaches (processes, methods and tools), if the current procedures and tools prove to be inadequate.

Indeed, the HBIM approach may be efficient to collect, storage and share the knowledge as files or hyperlinks, but it may be inefficient in the correlation of the data and information derived from several channels for supporting the automation of the diagnosis. The perspective is the introduction of computing systems toward the application of Artificial Intelligence in refurbishment, also to promote the migration from BIM Maturity Level 2 to BIM Maturity Level 3. Nevertheless, this requires an effort in changing cultural view maybe really applicable in the future. In the meanwhile, the basis may be generated to traduce the human cognitive capability into a machine-driven diagnosis and project.

Another aspect needs to be clarified in order to establish a valid and extensive methodology. The refurbishment can interest different typologies of buildings, in terms of period of construction, constructive techniques, functional use, local traditions and environmental and climate conditions.

Therefore, the refurbishment may address different objectives according to these features and proceed employing differentiated equipment and methods to assess the performance.

For example, the objects of intervention could be historical unoccupied or occupied constructions. The former may be refurbished in order to be preserved as documentation of cultural roots and valorised to be re-introduced in the loop of economic increase, after being suffering years of abandonments and scarce treatments. The latter could have lack of performance that could affect the occupants comfort, health and safety and economic efforts, both before and after an incorrect intervention.

The approach is divided in three main parts:

PART 1 consists of the preparedness activities for the management of resources (actors, information and data, files):

1. ONTOLOGICAL KNOWLEDGE STRUCTURATION [OKS] illustrating contractual conditions and organisational models with the aim of establishing effective co-operation and unambiguous communication since the preliminary stage (Dwairi and Mahdjoubi, 2016).

- 1.1 WORK ORGANISATION [WO] involves the professional assignments, competencies and responsibilities within the BIM approach. In this moment, the BIM Execution Plan (BEP) may be drawn up for defining the goals and uses of BIM, information exchanges and it supports for implementation within the process phases (Messner et al., 2011)(BuildingSMARTAlliance, 2015)(PAS 1192-2, 2013). Within the BEP, the design of BIM project execution process consists of business process mapping and information exchange definition with the specification Business Process Management and Notation (BPMN). In this moment, the LOD (PAS 1192-2, 2013)(BIMForum, 2016)(AIA, 2013), data and model requirements, digital exchange models and ontological information for refurbishment are defined. A classification of data/information is needed for the knowledge representation and management of decisions, involving data mapping for each building component model and work phase. This classification involves information management models and standards, such as ontologies, Model View Definition

(MVD)⁵ and IFC (Industry Foundation Classes), to eliminate inconsistencies, redundancies, providing communication protocols and promote interoperability.

2. PRELIMINARY INFORMATION COLLECTION [PKC] for creating:

2.1 KNOWLEDGE FRAMEWORK [KF], after raw geometric survey, preliminary analysis of materials/construction techniques and typological studies may be performed based on historical and photographic records, archival documentation and prior available drawings, in order to discover traditional constructive methods and past transformations and events, which probably have caused the current degradation. The information gathered during this step are relevant for detailed planning of more systematic investigations.

3. REVERSE ENGINEERING [RE] that delivers a geometric, textured and measurable three-dimensional model after:

3.1 DATA ACQUISITION [DA] with 3D laser scanning, photogrammetry, traditional methods or hybrid procedures, to solve the problematic detection of transparent, reflective or dark surfaces via photogrammetric acquisitions;

3.2 DATA ELABORATION [DE]

4. POINT-TO-BIM/SCAN-TO-BIM [Sc2BIM] that consists of:

4.1 3D MODEL PARAMETERISATION [PM]

4.2 BIM OBJECT LIBRARY POPULATION [LP]

PART 2 is the core of the methodology itself, introduced in the traditional HBIM approach, after having analysed traditional processes of acquiring incremental

⁵ Model View Definition (MVD): for assisting BIM data exchange in cross-platform data transfer mapping exchange requirements for one or multiple model exchanges to a data schema, like the IFC schema. The MVD documentation provides information needed for the exchange of BIM model referencing the IFC standard. An IFC MVD or an IFC view definition specifies a subset of the IFC schema that is needed to satisfy one or many exchange requirements of the AEC industry. Example exchange purposes supported by defined MVDs include conceptual model coordination, structural analysis, and clash detection (BuildingSMARTAlliance, 2015).

knowledge for diagnosis and performance assessment. The aims of this step are (Figure 3.1-1):

5. PERFORMANCE ASSESSMENT [PA] for gathering knowledge and semantic enrichment of BIM models with the purpose of evaluating the residual performances. Indeed, the information is made available to simulate structural behaviour, energy performance, as well as to plan energy retrofitting and structural reinforcement. Firstly, it consists in the visual inspection for mapping cracks, pathologies, anomalies in 2D views and drawings, as experimented with so far, or involving augmented visions using laser scans and photogrammetry for Computer Vision methods (gaming, holographic devices, immersive Virtual Reality, Augmented Reality). As complementary verifications, non-destructive tests could be performed for:

- 5.1 MATERIAL/CONSTRUCTION TECHNIQUES RECOGNITION [MCR]

- 5.2 DETERIORATION CONDITIONS [DC]

The infrared and thermal testing can detect constructive technologies mapping superficial temperatures and provide temperature values to estimate thermal properties to be recorded onto correspondent parametric objects. The continuous monitoring of temperature and humidity via SCADA (Supervisory Control and Data Acquisition) solutions, such as RFID and Internet of Things (IoT), is relevant to energy analysis in dynamic heat transfer mode. The diagnosis and monitoring of structural performance require the execution of non-destructive tests (georadar, sonic and ultrasonic tests, etc.) in order to investigate extensively decay phenomena and constructive techniques below component surfaces, to be accepted after local destructive diagnostic tests on representative building components, so as to extend the results to similar components. The real-time synchronisation and update of the BIM models should include environmental and structural – both static and dynamic – measurements, whereas occupant perceptions can drive more comfortable and sustainable solutions. For instance, the structural monitoring can measure the deformations which have the greatest influence on the global structural behaviour as analysed by

dynamic identification or it can control the progression of cracks, air temperature, humidity and wind. This information can be managed within the approach in different way, according to the BIM maturity level of the working team. For example, the BIM Level 2 is still a file-based maturity, and documentations and models are distinctly shared as hyperlinks or in the Common Data Environment (CDE); the projection is the development of a BIM Level 3 aiming at the transformation in data-based processes.

- 5.3 METADATA INCLUSION [MI] concerning information on investigation and installation plan, target elements (column/pillar, wall, time, etc.), acquisition profile typology, number of survey points and their geolocation.
- 5.4 MACHINE-DRIVEN DIAGNOSIS AND ASSESSMENT [MDA], the preliminary knowledge, the recognised pathologies and cracks, the experimental data could enter algorithms of reasoning in order to automate the diagnosis. If the current efforts are providing way of creating flexible and customizable tools for reasoning mainly controlled by humans, the projection will be the involvement of the Artificial Intelligence through the machine learning and the deep learning.
6. REFURBISHMENT PROJECT [RP] leads to the selection and detailed design of the most coherent interventions after the accurate diagnosis and performance assessment. These should fit the functional, standards or technological upgrading requirements. The selection could be aided by specific:
 - 6.1 DECISION SUPPORT SYSTEM [DSS] based on soft computing (i.e. fuzzy sets, neural networks) or multi-criteria analysis.
 - 6.2 ENERGY/STRUCTURAL BEHAVIOUR SIMULATIONS [ESS] of the alternatives of intervention.

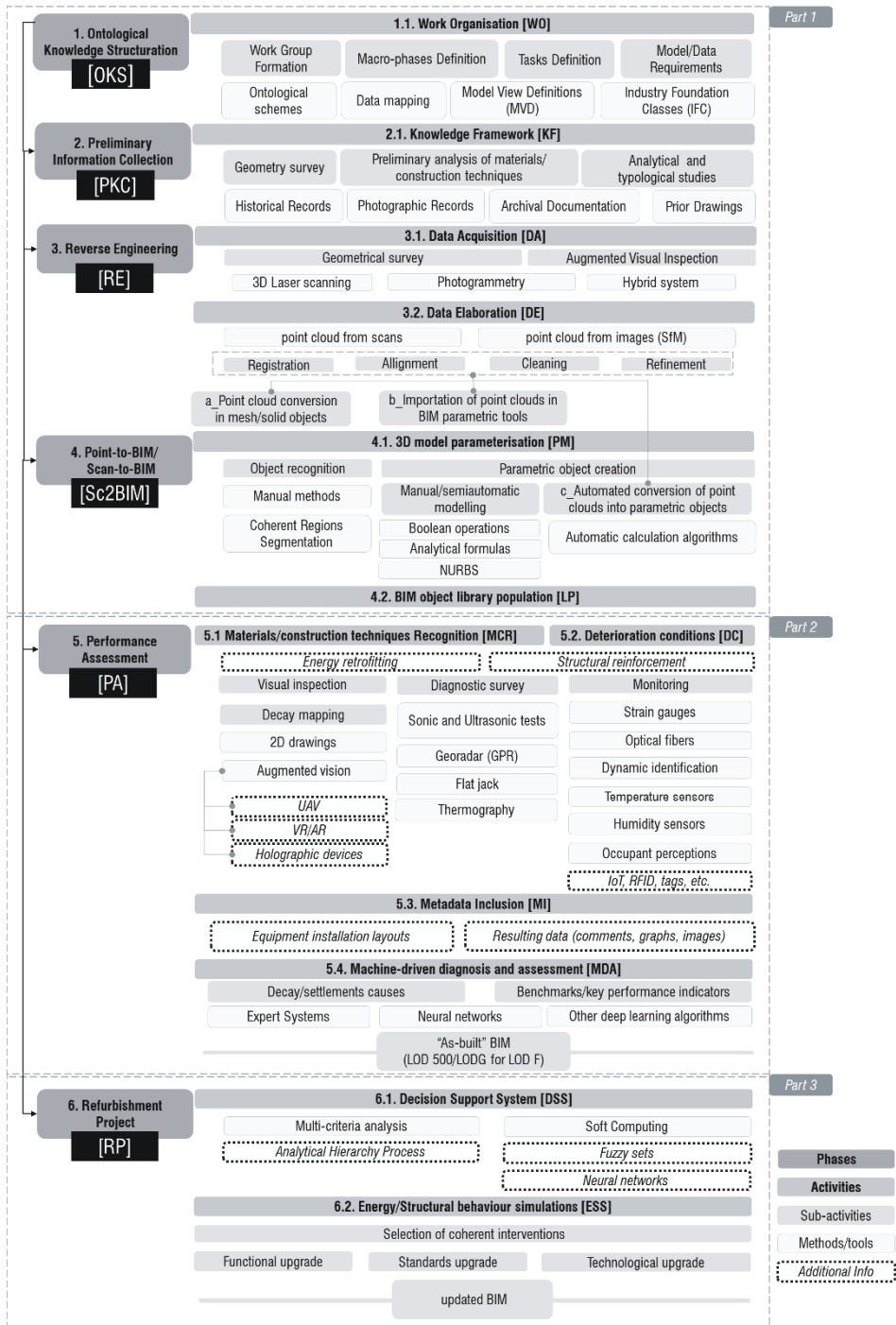

Figure 3.1-1 Structuration of the DA-HBIMM methodology. Source: author.

3.2 Guidelines for knowledge structuration and work organization [OKS]

The absence of clarity and shared dictionary obstacles for a successful BIM delivery, thus a primary implication among professionals and clients is the definition of requirements related with the BIM uses, involving heritage conservation projects and asset management of historic buildings and sites.

The communication and handover of information must be organized in two levels: the definition of information requirements by the clients within the employer requirements, in collaboration with the suppliers that are in charge of offering a BIM strategy for information delivery. For this reason, BIM guidelines exist as effective BIM standards in order to manage consistent BIM data during the entire Building LifeCycle Management (BLM) (GSA-U.S. General Services Administration, 2007)(Historic England, 2017). The Historic England suggests the employment of the PAS 1192 also for heritage conservation projects, thus the process begins with the definition of the EIR, that can be written in the BIM Protocol, and the suppliers present the BIM strategy as a BIM execution plan (BEP) (Construction Industry Council, 2013). The EIR establishes information (models, documents and data) generally required and also specified at each project stage, via an Information Delivery Plan (IDP)⁶.

In response, a BEP should describe the information management approach, outlining roles and responsibilities and setting project milestones as information delivery. Two BEP should be prepared: pre-contract and post-contract; the contents are presented in the PAS 1192-2:2013 in section 6.3 and 7.2 respectively. Differently from UK, the National BIM Standards – United States introduced the use of process mapping in order to support the fulfilment of project requirements and deliveries, such as the Business Process Notation Map (BPMN)⁷ (BuildingSMARTAlliance, 2015). The entire BIM model can be exported as IFC 4 (release 15 July 2016) and use it in further BIM platform as

⁶ Information Delivery Plan (IDP): it specifies the information required, the presentation order, the specific stage, and the actors responsible for it. It documents the information exchanges and their contents on a project from the user's perspective and agreed by committee ((Eastman et al., 2011).

⁷ Business Process Modeling Notation (BPMN): electronic e-business planning and implementation, for modeling exchanges; it is a clear method for describing activities and the information flows between activities (www.bpmn.org)

it is an object-based open standard, containing the geometric information and some non-graphical information (ISO/TC184/SC4, 2013). In addition, other information management models and standards should be declared (ontologies, Model View Definition, etc.).

3.3 Surveying as-is/as-damaged conditions [RE]

3.3.1 Data capture and augmented visual inspections

Some of the selected case studies have been surveyed with traditional manual methods and via photogrammetric survey, in order to evaluate advantages and disadvantages of this technique. As emerged in the literature review, the laser scanning has some critical aspects such as the intensive elaboration of scanned point clouds for alignment, registration and three-dimensional modelling in terms of expensive and powerful technical resources (equipment, hardware, software) and time-consumption in data management (Volk et al., 2014), in addition to the necessity of elevated economic investments for acquiring the equipment. Conversely, the photogrammetric survey is executed with a photo-camera on a tripod, a telescopic stick or installed on a UAV in order to acquire inaccessible environments because of height, risk of collapse or spatial tightness. The impossibility of acquiring some spaces has been taken into account because an acceptable results of the close-range acquisition depends on environmental boundaries and constrains. Consequently, the innovative technique has been combined with the traditional one. The 3D photo-reconstruction requires smaller number of tools than laser scans and point cloud processing. In this research, three software products have been employed and compared, Photoscan© Agisoft, Remake© Autodesk and Recap© Autodesk (desktop and cloud versions) for generating 3D reconstructions. Taking into account some differences in formulation and workflow of algorithms, these software products execute the multi-view stereo matching of the photo-shots through the bundle algorithm - part of the Structure for Motion -, the feature matching (points with stable viewpoint and lighting variations) and accurate algorithms for detecting correspondences. Then, they carry on the dense surface reconstruction via methods based on pair-wise depth map computation and multi-view approach (such as Patch-based

MultiView Stereo (PMVS) and Cluster based Multi View Stereo (CMVS)). The last step is the texture mapping after parameterising the surface and employing blended source photo for the texture (Westoby et al., 2011). If the 3D mesh, converted from the dense point cloud, requires further adjustment, it could be elaborated in further external software such as MeshLab, for executing Poisson or Ball Pivoting surface reconstruction and optimising algorithms. The deliverables of 3D photo-reconstruction and laser scanning can assist or replace the in-situ visual inspection when the building is not accessible, localized in foreign country or further observations are necessary in remote; in this case, their usage is for augmented visual inspection, so called because of the possibility of visualizing and integrating a framework of information in real and virtual building models via Computer Vision methods (gaming, holographic devices, immersive Virtual Reality, Augmented Reality) (De Fino et al., 2018).

3.4 Parametric modelling [Scan2BIM]

3.4.1 From point cloud/mesh to HBIM model

The process includes the segmentation of point clouds or meshes after manual or automatic object and feature recognition.

A classification of the current methods of modelling and parameterisation within the step 4. Sc2BIM can be provided:

- a. **Point cloud conversion in mesh/solid objects** (Macher et al., 2014)(Rodríguez-Moreno et al., 2016)(Banfi et al., 2017). Then, meshes are converted into 3D solids with faces extrusion and NURBS (Non-Uniform Rational Basis-Spline) into solid modelling software tools (generative tools), external to BIM platforms (Figure 3.4-1), via automatic and manual operations. This method is efficient when irregular and complex surfaces may be modelled (i.e. vaults) with flexibility. This is possible due to the use of interoperable and open source formats (such as *.dwg, *.dwx, *.sat (ACIS files)).

- b. **Import of point clouds in BIM parametric tools**, in order to trace reference lines from the point clouds and modelling (López et al., 2017) by Boolean operations and B-Rep (Boundary Representation).
- c. **Automated conversion of point clouds into parametric objects** that allows automatic recognition and generation of parametric objects from the point clouds, using specific plug-ins (i.e. the Leica Geosystems CloudWorx for Revit, that replaces Scan-to-BIM® by IMAGINIT, EdgeWise® ClearEdge that currently works only with laser scanned data, and the As-Built for Autodesk® Revit® - plug-in of a FARO Technologies' platform - including PointSense for Revit®, and Pointfuse®). These tools are able of recognising objects created from primitive geometries (walls, pipes, doors, windows), and work with recognition and best fitting algorithms.

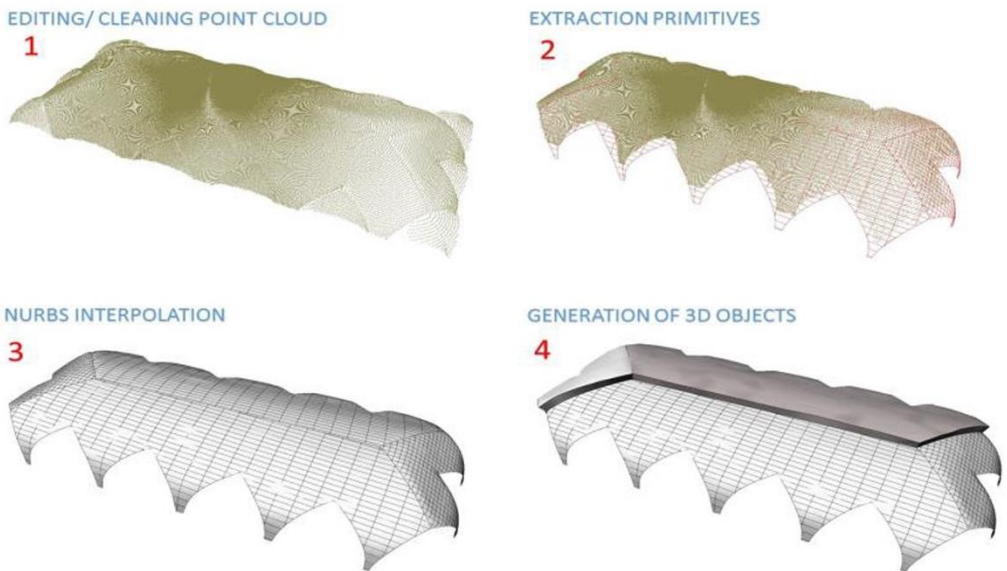

Figure 3.4-1 As-built BIM of the main vault of Masegra Castle with method (a)(Banfi et al., 2017)

The next step is the evaluation of the Level of Accuracy, taking into account the national and international guidelines and the project objectives. The assessment of the quality of the as-is/as-built model from point clouds is carried on with deviation analysis (Anil et al., 2011). The “Level Of Accuracy (LOA) Specification Version 2.0” is defined by

the US Institute of Building Documentation as a reference for clarify the level of accuracy in documenting the existing building (USIBD, 2016), and classified as the Table 3.4-1 at a confidence level of 95 percent:

| Level | Upper Range | Lower Range |
|--------------|--------------------|--------------------|
| LOA10 | User defined | 5 cm |
| LOA20 | 5 cm | 15 mm |
| LOA30 | 15 mm | 5 mm |
| LOA40 | 5 mm | 1 mm |
| LOA50 | 1 mm | 0 |

Table 3.4-1 Level of Accuracy (USIBD, 2016)

The abovementioned LOA may be comparable with the precision required for architectural restitution scales in restoration and refurbishment and other BIM standards about LOD. The level of accuracy accepted is maximum 3 cm of more than 60% of processed points (Quattrini et al., 2015). Generally, the accuracy can be assessed by the open source software tools CloudCompare, using the point clouds as reference (Quattrini et al., 2015)(Rodríguez-Moreno et al., 2016), or MeshLab to measure differences between two meshes. In this research, the deviation analysis is only performed for automatic modelling in As-built© for Revit plug-in, in order to test the feasibility of automation and precision with dedicated software tools.

Being the model of an existing building effectively an “as-built model”, the professionals may aim at reaching a high geometric the Level of Detail of the model equal to LOD500, and Level of Detail of the objects according to the objectives (architectural representation or analytical modelling for technical simulations). However, the model should have a sufficient detail in order to display masonry textures, cornices, and other ornamental components. In Italy, the correspondent LOD is Level of Development LODG (UNI/CT033, 2017), the geometric reliability is denominated LOG⁸ by the UNI committee in order to detail and constructive model with the same technical and informative

⁸ LOG: Level of Development: geometric attributes, it corresponds to the level of detail and stability of the geometric attributes of the digital objects within the model; the Level of Geometry and the Level of Information make the Level of Development

contents and more accurate graphic features (1:50 scale) (Quattrini et al., 2017)(Chiabrando et al., 2017); the LOG corresponds to the Level of GRaphic DEtail (GRADE) Grade 3 (Caffi et al., 2014). Some models can present model elements about existing buildings with LOD 350 (BIMForum, 2015)(Historic England, 2017)(Biagini et al., 2016), as base for executive planning. In the specific case studies, the parametric modelling has been executed with method (b) and (c).

3.5 Semantic enrichment [PA]

3.5.1 Decay mapping in HBIM

As explained in the previous paragraphs, the decay mapping and analysis are information requirement for refurbishment. The methods for representing the “as-damaged” condition discussed in literature are enumerated below:

- 1) Decay patterns are not represented in the model, but reported as ad-hoc tables linked to different object elements; the information contained regard problems, causes of the decay, state of conservation and actions to be performed (Rechichi et al., 2016)
- 2) Drawings of decay patterns in 2D view extracted from the 3D model (Bruno et al., 2016) (Quattrini et al., 2017); the drafting view is linked to the related Wall instance (Rodríguez-Moreno et al., 2016);
- 3) 3D modelling from CAD mapping drawings of materials and decay (Brumana et al., 2017) (Brumana et al., 2018);
- 4) 3D modelling from segmentation and conversion of point clouds or meshes and use of adaptive component (Bruno et al., 2017b)(Chiabrando et al., 2017):
- 5) Depicting of moisture measurement through a customized Dynamo algorithm (Pocobelli et al., 2018a)
- 6) Automatic extraction of cracks from ortho-images, textures or rectified images via edge detection and conversion in polylines, a method proposed in this work that is being investigated in Computer Science and Civil Engineering (Mohan and Poobal, 2017), and contemporarily developed in BIM systems for maintenance of existing bridges (Dang and Shim, 2018).

3.5.2 Information requirements and Level of Information in refurbishment

The BIM model is not only a graphical representation of the building, but it also comprises the required information to effectively manage the entire life cycle of an asset.

In this perspective, the UK government asked for a collaborative 3D BIM, including all the information about the project and the asset, electronic documentation and data, as a minimum requirement for BIM Level 2 (PAS 1192-2, 2013). In particular, the PAS 1192-2:2013 introduces the Employer's Information Requirements (EIR) defining the required information by the employer from both the internal team and from each supplier for project and operation, and the standards and processes to be adopted by the suppliers during the project delivery process. The configuration of an EIR is an iterative process that provides more specific requirements about systems and building components during the project, defining information for maintenance and operation at the end of the project. In refurbishment, the concept of Information Requirements calls for clarification in an international context, aware that it affects the method of organizing the Information Management, then the articulation of the technical requirements about the LOD thus the Level of Information (LOI) (PAS 1192-2, 2013)(UNI/CT033, 2017). Whilst, in USA, the LOI matches the Associated Attribute Information reported as the non-graphical attributes in a spreadsheet (Bolpagni, 2016)(BIMForum, 2018).

As introduced, the UNI 11337-4:2017 is the first national standard including specific LOD for refurbishment and restoration, being activities that involves a continuous management of the knowledge which starts from the content of previous interventions (LOD F) implemented with subsequent management activities (LOD G). The specific analysis (structural, energetic, behavioural, computational analysis) can be executed on low LODs (LOD D or E). If the information about previous interventions are not available, activities may be executed in order to reach a Level of Detail and Information equal or higher than LOD F; among these activities, surveys about material characterization and previous interventions are considered (Bruno and Fatiguso, 2018). The object in LOD F is the virtualization of the current conservation status of the as-built, indicating programmed management intervention, maintenance e/o repair. In LOD G, the virtual model is the updated state-of-the-art of an entity in a determined time. It corresponds

to the historical representation of the life cycle of a specific system updated from the former interventions. In this case, every single management intervention, maintenance, repair, executed during the life-span, and the current decay patterns may be annotated (UNI/CT033/GL05, 2017)(UNI/CT033, 2017)(Brumana et al., 2017)(Bruno and Fatiguso, 2018). The refurbishment/restoration calls for a “complex-mixed LOD approach” in order to support decisions about preservation, restoration and management, focusing in involving the unicity and multiplicity of building and architectural components (Brumana et al., 2018). The Level of Information may be introduced to support the preservation process, to document the “as-built” and the management of the building after the intervention during the entire Life Cycle Management process (LCM) (Brumana et al., 2018). This is reporting materials, construction technologies and decay analysis. The information requirements comprise the results of preliminary investigations, physical properties, diagnostic tests, metadata, provided by diagnostic tests and bibliographic research, into the parametric object as project properties, associated to object types or instances, with the possibility to structure them in schedules, views and sheets. Preliminarily, the definition of data structure must be selected, agreed upon and reported by the team in the organisational documents, as part of the BEP. The data structure comprehends data type (Figure 3.5-1) and the associated BIM object, and relates COBie attributes and added parameters. If Autodesk Revit is employed as BIM platform, the Share Parameters file should be employed to identify properties (GSA-U.S. General Services Administration, 2007).

For example, a masonry wall may be codified by an alphanumeric ID, composed by the typology (i) multiple-wythe unit masonry (MultiWM) or (ii) Single unit masonry (SM) and reference cardinal point.

Non-destructive diagnostic tests firstly provide multimedia or digital file (video, images, graphs) to be interpreted compiling textual comments or inserting integer/real values with its measurement unit in correspondence of physical properties (thickness, thermal and mechanical parameters) into the parametric objects. The information requirements may be placed into the objects model also defining the temporal phase ‘as damaged’.

| Attribute / Parameter | Data Type | Description | Responsible Party |
|----------------------------------|-----------|---|-------------------|
| Recycled Content | Number | Percent of the item's content that is recycled. | Shared |
| Pre-Consumer Recycled Content | Number | Percent of the item's content that is pre-consumer recycled. | Shared |
| Post-Industrial Recycled Content | Number | Percent of the item's content that is post-industrial recycled. | Shared |
| Post-Consumer Recycled Content | Number | Percent of the item's content that is post-consumer recycled. | Shared |
| Manufacturer Location | Text | Location of item's manufacturer. | Shared |
| Item is New | Yes/No | Is the item new | Shared |

Figure 3.5-1 Example of attributes/parameters for green building properties. Source: (GSA-U.S. General Services Administration, 2007).

3.5.3 Analysis and management of diagnostic tests and results

In a traditional approach, the reports of diagnostic tests and other documentation about the refurbishment project are separate paperworks that generate difficulties in retrieval data to plan interventions and program maintenance. The DA-HBIMM approach may lead to the integrated analysis and management of diagnostic test through several methods, due to the flexibility of BIM procedures and tools for data management.

The selection of information exchange formats and methods depends on the BIM maturity of the team project; if the involved actors work with federated models and file-based processes (BIM Level 2-UK), the analysis and management of diagnostic tests will be performed creating tables and views from 3D BIM models or sharing electronic documentations linked to the BIM objects or uploaded in a Common Data Environment, frequently in proprietary information exchanges formats. Consequently, the interoperability is limited because of the use of non-common group of exchange formats, instead of open standards, to read and write the same file formats, with the same protocols (Succar, 2009)(Eastman et al., 2011). Whilst, in the perspective of working with integrated web-based services (BIM Level 3-UK), software systems will launch functions and exchange data via web, stepping forward the solution of the interoperability problem (Jiang et al., 2016). The potentiality of working with BIM servers may provide the

basis of evolving the BIM approach toward computing data through Artificial Intelligent, switching from knowledge readable by humans to data computed by machines for supporting humans decision making. This feature may be an opportunity for extracting diagnostic results from texts, words, images and videos in the future.

During the three years of research, data and metadata have been initially recorded as object attributes, with the aim of investigating the known capabilities of BIM tools. In this method, the diagnostic tests may be modelled as independent objects that represent acquisition profiles, with a coded name type and related attributes such as the acquisition file, the execution methodology, the description of the equipment, the output (measurements, images, graphs, etc.) and comments about results.

The Table 3.5-1 shows an example of template for the recording of attributes about diagnostic tests in the BIM object representing the “*acquisition profile*”:

| <i>Generic model: Type/instance attributes</i> | | |
|--|--|------------------|
| Type | | Data type |
| GPR_ProfileAA_L01 | Naming type: GPR_Profile[Profile-Code]_L/T[n profile], Longitudinal/Transversal | Text |
| Text | | |
| GPR Profile Code | [ProfileCode]_L/T[n profile] | Text |
| Data | | |
| GPR_Acquisition File | [ProjectName]/[yymmdd][Profile-Code].ZON | Text |
| GPR_Methodology | <ul style="list-style-type: none"> - Reference point for profile localization (height, distance); - Number of longitudinal (L) and transversal (T) profiles; - Distance among profiles; - Total area investigated (for three-dimensional profiles) | Multiline text |
| GPR_Equipment | <ul style="list-style-type: none"> - Type of Acquisition Unit - Type of antenna, Voltage and Frequency | Multiline text |
| GPR Radar image | AA_L01_070.png | Image |
| GPR_Comments | | Multiline text |

Table 3.5-1 Template for recording diagnostic tests attributes in BIM object. Source: author.

After structuring and attaching parameters, these may be utilized for creating drawings or schedules, or shared as exported database.

In the perspective of working in BIM Level 3, an integrated approach is envisaged for fully connecting the data chain to be available also for building management. In a Level 3 system, BIM data is not converted into files and emailed or sent via file transfer protocols sites, but the knowledge is available in a database on the cloud, and accessible by all project actors through web services (HM Government, 2015)(Eastman, 2016). Some initiatives have been started to permit developers and innovators developing customized cloud-based software applications for connecting workflows within collaborating companies (i.e. Forge Autodesk©, Microsoft© Azure, Google© Cloud, etc.). Hence, the research work also proposes a Cloud-based HBIM portal, a web-service set up in collaboration with the Centre for Architecture and Built Environment Research (CABER) – University of West England(UK) in order to test it in sharing of knowledge, including diagnostic results (see Section Web-based documentation, analysis and sharing: the Cloud HBIM portal).

3.5.4 Analysis and management of monitored building performance

Some applications demonstrated how BIM provides significant benefits for a deeper knowledge of existing environmental conditions (e.g. thermal, lighting, and acoustic). Most of them integrate BIM tools with Building Performance Simulation (BPS) tool. Nevertheless, there are factors that need to be monitored and not only simulated for a very effective and efficient process for implementing retrofit strategy (Habibi, 2017). Certainly, in the Building Lifecycle Management would be essential the real-time monitoring of building performance via capturing sensor data (energy consumption, temperature, humidity, occupancy, etc.). For example, particular situations could be represented by the assessment of building performance before and after energy retrofitting or structural consolidation, for firstly planning and afterward testing the current efficacy of interventions. In addition, monitoring and control both outdoor and indoor environmental parameters in real-time could help users through early warning measures for better indoor environmental quality.

This is featured by the real-time analysis, management and handover of a large amount of data and information (Shi et al., 2016)(Abdelalim et al., 2017), and this makes unpractical the file-based BIM collaboration. Gerrish et al., 2017 (Gerrish et al., 2017) estimated the capability of Building Information Modelling in plotting and managing building performance due to the connection of BIM tools with Building Management Systems (BMS) data environments. In the specific framework, this research work will investigate the practicability of employing these technologies for supporting decision in energy retrofitting, focusing on the issue occurring in English historical buildings about risk of condensation and mould growth after insulation interventions (May and Sanders, 2017). Recently, this issue is motivating studies and gathering of data about retrofit and renovation of existing building, so as to improve national and international standards, currently more focused on new constructions. The most affected assets are the older solid-wall buildings. The Sustainable Traditional Building Alliance (STBA) suggests the development of an integrated approach in order to address the complexity of the issues. The BIM approach and BMS could help in researching possible practical solutions through advances in performance optimisation tool (Gerrish et al., 2017)(Habibi, 2017). In fact, the crucial step is the handover of the retrofitted building to the users, because if there is not support in this initial process, the results could be very different from the simulation (Thabet et al., 2016)(Gerrish et al., 2017). Nevertheless, the integrated web services (or BIM repository (Eastman et al., 2011)) may facilitate the information management being a server system with capability of queries, handover and updating within a single workspace, with the possible of having the interaction of connected multi-agents, such as humans, sensors and devices, with the possible result of increasing epistemic actions and knowledge (Shi et al., 2016).

3.6 Automated diagnosis via DA-HBIMM [MDA]

3.6.1 Image processing for automated decay mapping

The introduction of Computer Vision and Image Processing in the field of Civil Engineering and Architecture has had significant impact in distinct actions.

Generally, cracks and defects are detected also combining signal processing methods and other techniques. Different filters exist for image processing, in particular for edge detection, such as Sobel filtering, Canny filtering, fast Haar transform (FHT), fast Fourier transform (FFT) and wavelet transform-based method. Despite the development of more reliable methods, as for example the FTT in the work of Dhule et al., 2016 (Dhule et al., 2016), the automatic decay mapping and crack detection is going to be based on stable and simple algorithm, thus it requires low computing work of the hardware, being an application that should run by the most commonly used notebook and personal computer.

The image processing can help the automatic site inspection system (Mohan and Poobal, 2017), in addition it can support the automatic graphical representation of decay mapping and 2D objects. In the case studies, two edge detection operators will be employed even though they are not the most sophisticated: the Canny operator (Figure 3.6-1) (Canny, 1986) and the Sobel operator (Figure 3.6-2)(Sobel, 1970).

The captured image is imported in an ad-hoc computing algorithm developed in Dynamo Studio© Autodesk. The computing nodes are customized via scripts available in library for routines and filters of image processing (AForge.Image.dll) developed by AForge ver. 2.2.5.0. AForge is an open-source platform of algorithm in C# useful for developers and researchers that work in the domain of Computer Vision and Artificial Intelligence ('AForge', 2013).

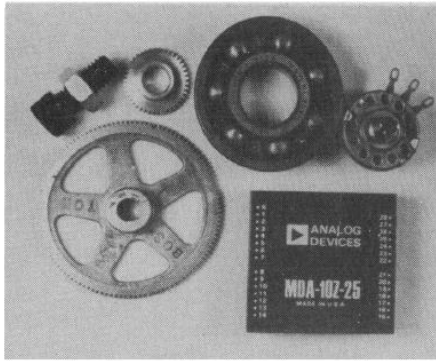

(a)

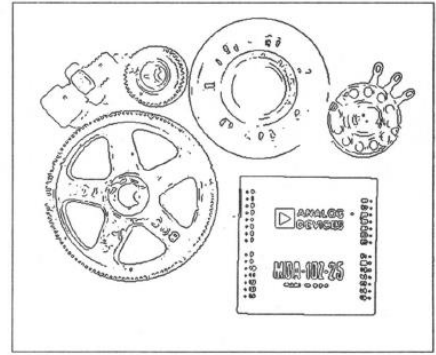

(c)

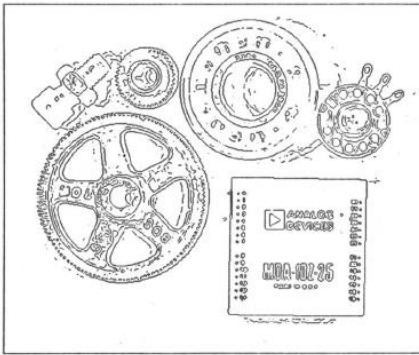

(b)

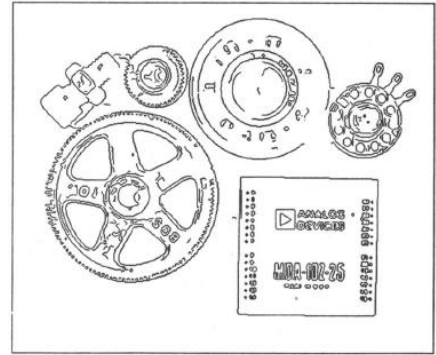

(d)

Figure 3.6-1 Example of Canny detection application, with two thresholds and hysteresis (Source: Canny, 1986).

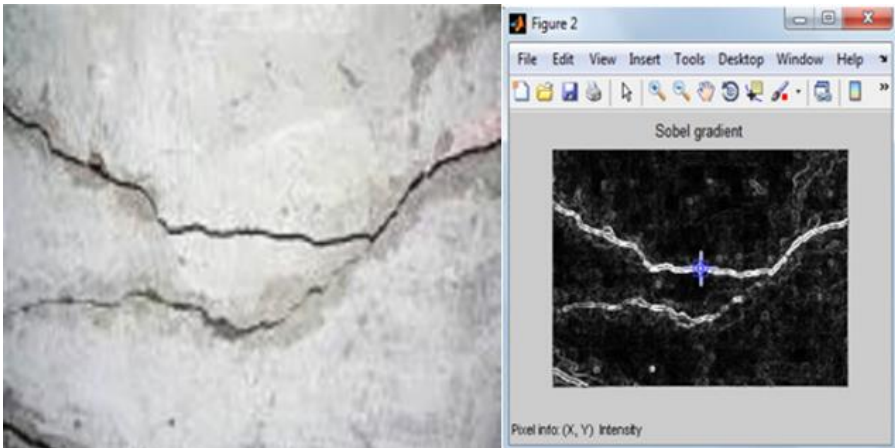

Figure 3.6-2 Example of Sobel detection application. Source: (Dhule et al., 2016).

The edge detector may be able of processing signals in a way of reducing influences or eliminating unrelated objects or noises, as it can occur in complex environments as in historic buildings.

The first step is the scaling of the image in a way it is in real dimensions, or keeping with the capture resolution and, successively, calculating the real dimensions of the cracks with the purpose of reducing computing efforts.

(Canny, 1986) has followed development criteria of existing operators with the aims of i) reducing errors and avoiding that some edges could be unrecognized instead of the false; ii) improving the localization of points, because the distance among the detected pixels and the real edges will be the lower; iii) associating only one recognition to an only one edge.

The fulfilment of these criteria depends on the execution of the following optimization algorithm:

Step 1 - Grayscale Conversion: the filter works on images in greyscale in 8bpp.

Step 2 - Gaussian Blur: the convolution mask erases the noise, employing a kernel 5x5, a dimension smaller than the image. The Gaussian smoothing can be performed using standard convolution method. The convolution of Gaussian filter uses 2D distribution. The larger the dimension of the convolution mask, the smaller the sensitivity to noise, in this way the localization error also increases. The mask is slid over the image, calculating every square of pixels at a time. The weight of the matrix is maximum at the centre, so as the noise appearing in the outside columns and rows will be eliminated, as the weight decreases outward from the centre value. The increasing of standard deviation σ reduces or blurs the intensity of the noise (Figure 3.6-3).

| | | | | | |
|-----------------|---|----|----|----|---|
| | 2 | 4 | 5 | 4 | 2 |
| | 4 | 9 | 12 | 9 | 4 |
| $\frac{1}{115}$ | 5 | 12 | 15 | 12 | 5 |
| $\sigma=1.4$ | 4 | 9 | 12 | 9 | 4 |
| | 2 | 4 | 5 | 4 | 2 |

Figure 3.6-3 Discrete approximation to Gaussian function.

Step 3 – Determination of the intensity gradient: after smoothing the image and eliminating the noise, the operator detects the regions where the spatial derivative are higher. The calculation of 2-D spatial gradient on an image is performed by the Sobel operator. The formula of gradient magnitude is (1):

$$|\mathbf{G}| = \sqrt{\mathbf{G}_x^2 + \mathbf{G}_y^2} \quad (1)$$

Then, the use of the approximate gradient magnitude formula below permits calculating the approximate absolute gradient magnitude (edge strength) at each point, in a simplified method (2):

$$|\mathbf{G}| = |\mathbf{G}_x| + |\mathbf{G}_y| \quad (2)$$

The gradient G_x in the x-direction (columns) and the gradient G_y in the y-direction (rows) are calculated using a couple of 3X3 Sobel convolution masks (Figure 3.6-4):

| | | | | | | |
|-------|---|----|-------|----|----|----|
| -1 | 0 | +1 | | +1 | +2 | +1 |
| -2 | 0 | +2 | | 0 | 0 | 0 |
| -1 | 0 | +1 | | -1 | -2 | -1 |
| G_x | | | G_y | | | |

Figure 3.6-4 A couple of 3X3 Sobel convolution masks. Source: (Gupta and Ghosh Mazumdar, 2012).

Step 4: Finding Gradient angle: the calculation of the edge direction. The formula is given below (3):

$$\theta = \text{invtan}(\mathbf{G}_y / \mathbf{G}_x) \quad (3)$$

If the sum of G_x is equal to zero, being in denominator, it would be an error.

Step 5 – Tracing the edge in the image using theta (angle) using a 5X5 matrix for calculating the angle of the edge.

Step 6 – Non Maximum Suppression: the operator eliminates pixels with lower value, where the gradients are higher.

Step 7 – Double Thresholding: selection of Low and High thresholds.

Step 8 – Edge Tracking by Hysteresis: the gradient array is further reduced to trace edges. The implemented hysteresis phase is simplified with respect to the theoretical

model, so as to reduce processing time, a fundamental aspect for integration into the complex process being processed. In the hysteresis phase, each pixel is compared with two threshold values: HighThreshold and LowThreshold. In the case where the value of the pixel is greater than or equal to the HighThreshold, this is considered as belonging to the boundary. Differently, if the value is greater than or equal to the LowThreshold, a boundary pixel is considered only if there is at least one adjacent pixel (among the eight adjacent) that has a value greater than or equal to the HighThreshold. In all other cases, the pixel is not considered a boundary; even the pixels are automatically discarded with values lower than the LowThreshold.

Step 9 - Cleaning Up

The Sobel operator have been also applied, independently from the Canny algorithm. In this case, after the use of the kernel for calculation G_x and G_y , the approximate intensity of each pixel has been calculated as (4):

| | | |
|----|----|----|
| P1 | P2 | P3 |
| P8 | x | P4 |
| P7 | P6 | P5 |

Figure 3.6-5 The Sobel mask: the pixel and its eight neighbours.

$$|G| = |P1 + 2P2 + P3 - P7 - 2P6 - P5| + |P3 + 2P4 + P5 - P1 - 2P8 - P7| \quad (4)$$

Subsequently, the contours are transformed into Cartesian points (x, y, z) that are connected by continuous and convex lines through the Convex2DHull operator or two-dimensional convex hull, in order to obtain the object as geometric curve corresponding to the detected crack pattern, eliminating the need to draw it manually from 2D images or orthophotos (Figure 3.6-6). The formula is the following (Gärtner and Hoffmann, 2013) (5):

$$Conv(S) = \left\{ \sum_{i=1}^{|S|} \alpha_i x_i \mid (\forall i: \alpha_i \geq 0 \wedge \sum_{i=1}^{|S|} \alpha_i = 1) \right\} \quad (5)$$

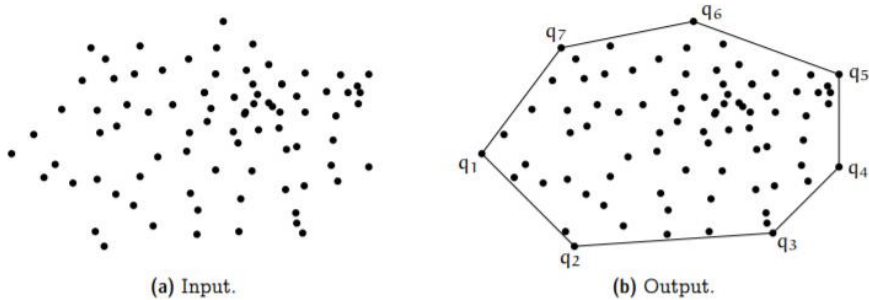

Figure 3.6-6 Application of 2D convex hull on a set of points. Source: (Gärtner and Hoffman, 2013). The automated decay mapping has been tested on masonry in limestone bricks affected by kinematic settlings, building pathologies and damages. The crack detection can be involved in the diagnostic tests because it could provide information about the dimensions of the cracks, the speed of propagation if monitored, the direction of propagation, applying the template matching and the percolation algorithm (Ehrig et al., 2009).

3.6.2 Inferential logic in the diagnosis of building decay

The first step of condition assessment of an existing building regards the fault/damage detection and the fault/damage diagnosis consisting of the determination of the real causes starting from observed effects. The condition assessment and the risk level evaluation can be calculated to complete the decision-making process and select priorities of interventions. Those intervention need to be addressed for eliminating the causes of the damage/fault and avoiding that the issues will compare back or generate further ones. In order to address these goals, an integrated tool is required with human/machine information processing and problem-solving ability. The diagnosis via rule-based reasoning may be defined by production rules which convert the experience of engineers/architects and literature about diagnosis domain into inferential rules expressing the “causes/effects” mechanism (Deng et al., 2017)(Sousa et al., 2018). The production rules is a method of knowledge representation consisting of a collection of rules with an IF part (or premises, antecedent part) and a THEN part (or consequent part). The premises conditions are collected by IF and connected each other with logical

connectives (and/or); THEN introduces one or more actions or conclusion when the premises are true. The facts entered by the user are temporarily stored in the working memory for the current state of a specific problem being solved.

The production system consists of three parts:

- Knowledge base that is a set of IF-THEN rules;
- A global database or working memory, and
- An inference engine.

This may be found in the Rule-based system that elaborate the knowledge for diagnosis within the rules of the inference engines. The inference mechanism or the control strategy can be of two typologies: forward-chaining and backward-chaining (Adeli, 1988).

- **“Forward-chaining** (also called antecedent reasoning and data-driven control strategy). It represents the logical repeated application of **modus ponens**. Forward chaining begins with the available data and uses inference rules to extract more data (from an end user, for example). The rules are examined until one is found whose premises match the information for the problem entered in the working memory (it is known to be true). This process is repeated until the goal state is achieved or no usable rule is found. Then, the rule is applied and the working memory is updated. Thus, the engine can conclude or infer the consequent. If the goal state is not known and has to be constructed or the number of possible outcomes is large then the forward-chaining mechanism is often recommended. This reasoning model is an implementation strategy for expert systems, business and production rule systems.” (Figure 3.6-7)

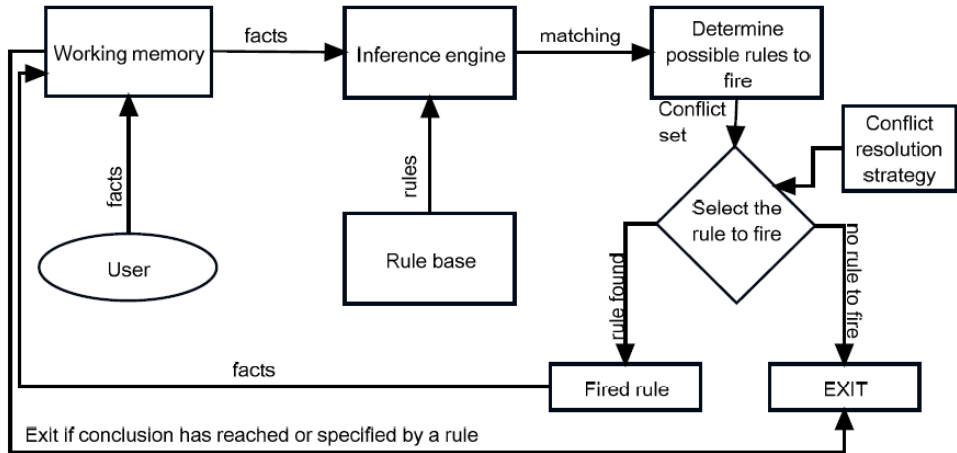

Figure 3.6-7 Forward chaining. Source: (Grosan et al., 2011).

- **“Backward-chaining** (also called consequent reasoning and goal-driven strategy). In this inference mechanism, rules are examined and those whose consequent actions correspondent to the goal are located. The control consists of verify if the antecedents of each rule match the working memory. If they all match, the rule is applied and the problem is solved. If there exists an unmatched antecedent a new sub goal is defined as 'arrange conditions to match that antecedent'. This process is applied recursively. If the values of goal state are known and their number is small then backward-chaining seems to be quite efficient. Backward-chaining is often employed in diagnostic expert systems.” (Figure 3.6-8).

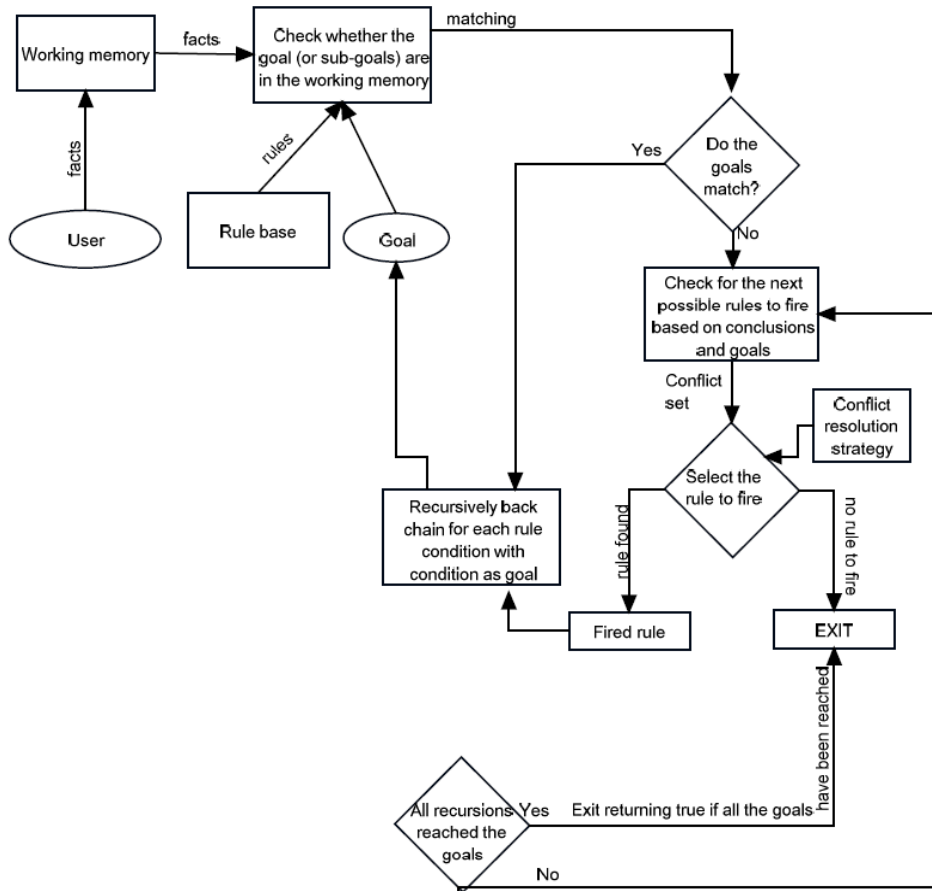

Figure 3.6-8 Backward chaining diagram. Source: (Grosan et al., 2011).

The data input is provided by a man-machine/machine-machine interface for knowledge acquisition, knowledge base repository, reasoning engine, with the aim of elaborating input data and providing conclusions about the category of failure/damage (building pathology or structural settlements) and suggest interventions. In this research methodology, the tools of the BIM platform will be tested as a man-machine interface and a working memory with the aim of automatizing the diagnosis via DA-HBIMM. The Query function of the rule class formulates the knowledge about the building diagnosis; each rule belongs to a chain of rules and generates a knowledge base.

In this system, the knowledge can be acquired from different sources: by human input, external databases, APIs for elaborating related data, every data is related to the correspondent BIM object. The system could be programmed for improving diagnosis rules by the automatic learning methods to correct the rate of fault diagnosis and adding knowledge acquired by diagnostic tests and monitoring.

The inference engine applied logical rules to the knowledge base and deduced new knowledge. This process would iterate as each new fact in the knowledge base could trigger additional rules in the inference engine. The rule-based implemented in this research is a forward chaining, starting from the known facts and asserts new facts.

The premises are heuristic symptoms (qualitative) and evaluated changes corresponding to analytical symptoms (quantitative).

The database of each damage pattern presents n facts (or symptoms) A, B, C, D, \dots, n and the knowledge base consists of the m given rules.

Rule 1: IF A AND C ... AND n THEN B (since both A and C are in the database);

In logic symbols:

$A \wedge C \Rightarrow B$; with A and C present in the database (they are true).

If new facts are obtained, they will be added to the working memory.

In the specific case, the global database/working memory is the BIM database of parameters in each damage pattern object, that contains the damage pattern (symptoms) $DP_1, DP_2, DP_3, \dots, DP_n$. If the facts are true, then the inference engine provides the consequent cause of damage (i.e settling typology and potential triggering events).

3.6.3 Degree of uncertainty

The complexity of causes that determine a damage/fault in buildings increases the uncertainty in the detection of relationship between causes and effects, because of the incomplete knowledge to formulate a decision. Consequently, the uncertainty and, also, the unawareness of its presence may lead to incoherent decisions.

The sources of uncertainty are shown in Table 3.6-1 (Grosan et al., 2011).

| | |
|------------------------|--|
| Imprecise language | Natural language has to be transposed into IF-THEN rules. But sometimes our language is ambiguous and imprecise. |
| Data | Incomplete Incorrect Missing Unreliable Imprecise |
| Uncertain terminology | Semantics |
| Uncertain knowledge | Need of monitoring and surveys |
| Incomplete information | Information is not sufficient for the expert system to make a decision. |
| Imprecise data | Different terms are used with the same meaning or a term has multiple (different) meanings. |
| Errors | Errors related to hypothesis Errors related to measurement Errors in induction |
| Different expert views | |

Table 3.6-1 Sources of uncertainties. Source: (Grosan et al., 2011).

The uncertainty in inferential systems is affected by the validity of facts, rule conditions and rules themselves, but the aim is being satisfied obtaining the best solution.

Some methods exist for attaining the best solution in light of uncertainty:

- Probability-based methods:
 - a. objective probability
 - b. experimental probability
 - c. subjective probability
- Heuristic methods:
 - a. certainty factors

b. fuzzy logic

Some theories have been developed in order to deal with uncertainty and solve problems that Boolean reasoning (deterministic logic) does not solve:

1. Bayesian Probability
2. Hartley Theory
3. Shannon Theory
4. Dempster-Shafer Theory
5. Markov Models
6. Fuzzy Theory

In the current research, the heuristic methods will be employed, because of the unavailability of a large amount of data and/or estimates from the experts, as required in Bayesian methods, according with the conclusion of MYCIN developers (ShortLiffe, 1976); in addition, a Bayesian system suffers the absence of explanations of how the conclusion has been inferred. The analogy of building diagnosis with medical diagnosis lead to the adoption of certainty factors theory in alternative to Bayesian reasoning, because the expert starts from evidences/symptoms to support or contradict a hypothesis.

In expert domain, the human reasoning provides conclusions in a weighted manner, employing not probabilities but heuristics, as resulting from experience (“unlikely”, “almost certain”, “highly probable”, “possible”). A certainty factor is neither a probability nor a truth value, but it is a consciousness of truthful or degree of confidence (Ishizuka et al., 1981) (Deng et al., 2017), quantified using linguistic systems or numeric scales (such as 0-1, 0-10, and -1 to 1).

Certainty factors may apply to:

- facts;
- rules (conclusion(s) of rules);
- both to facts and to rules.

The knowledge base with certainty factor is represented in the following scheme:

If $R_1(W_1, K_1)$ and $R_2(W_2, K_2)$ and...and $R_n(W_n, K_n)$

Then T With (CF, K)

$R_1, R_2... R_n$ represents the premise of a rule, also known as the failure symptom or facts;

$W_1, W_2..., W_n$ is the weight of each precondition of rules;

$K_1, K_2... K_n$ is the threshold of confidence, prerequisite rules of each;

T is the rule conclusion; CF ($CF \in 0 \sim 1$) is the rules of the credibility of the conclusion K ($K = 0 \sim 1$) is a rule established threshold, only when the true value is greater than or equal to K rules, this rule is activated.

The coefficient K_n corresponds to the level of confidence of the symptom/evidence, and it depends on the reliability of knowledge that the experts have been acquiring. These values may be determined by the professionals in a confidence production rule system. If the symptoms are deterministic, the answer will be affirmative, consequently the confidence is set to 1. The $CF = -1$ stands for the relevant confidence against the hypothesis; the $CF \approx 0$ indicates that there is limited evidence either for or against the hypothesis. Generally, the professionals have not a complete confidence about the connection of the symptom with a possible defect/damage of the fabric. The confidence level is strictly connected on the observed situation and the verification of potential facts with additional surveys and monitoring. The certainty factors depend on the measure of belief $MB(H,E)$ and measure of disbelief $MD(H,E)$ for a hypothesis H and an evidence E . The measure of belief is the level of believing in the hypothesis H when supported by observing evidence E , the measure of belief is the level of disbelieving in the hypothesis H when supported by observing evidence E . These measures depends on the prior probability of hypothesis H being true $P(H)$ and the probability that hypothesis H is true given the evidence E $P(H|E)$, and assume value between 0 and 1 (Grosan et al., 2011). Certainty factor is the difference between MB and MD (6):

$$CF(H, E) = \frac{MB(H, E) - MD(H, E)}{1 - \min\{MB(H, E), MD(H, E)\}} \quad (6)$$

The range of certainty factors values is $[-1, 1]$.

In this experimentation, the use of certainty factors is not related to the evaluation of probabilities, nor measures of believe or disbelief, but they are assigned by experts

according to evidences of supporting surveys. Thus, multiple sources of evidence produce CFs for the same fact, and more rules may provide evidence for the same conclusion, and the certainty factors of evidences and conclusion may be calculated as combination.

4 TESTING THE DA-HBIMM APPROACH

4.1 Overview of case studies

The previous sections underlined the complexity in managing the entire refurbishment process which begins from the acquisition of incremental and accurate knowledge about the fabric, investigating the historical assets, the material and constructive techniques and the state of conservation with the aim of identifying the real causes of decay and damage and implementing the coherent interventions. Therefore, the methodology proposed in the Section 3, denominated DA-HBIMM, intends streamlining the organizational and information flows to address this goal.

This approach has been tested in case studies characterized by different functional use, state of conservation, geometry, morphology, materials, technical components, and localization. In this perspective, the findings of the diagnostic phase could be different and they can support explaining building pathologies and damages, or they could assess the hygrothermal comfort and energy consumptions when a verification is needed before and after energy retrofiting.

In detail, some case studies⁹ are historical buildings located in Southern Italy and featured by masonry structures in stone or tuff bricks and mortar joints; some of them are

⁹ Some case studies have been analysed during a program of master theses about Historic Building Information Modelling in Building Engineering and Building Engineering and Architecture at Polytechnic University of Bari.

listed as cultural heritage by the Italian Ministry of Culture and Tourism. They are partially or totally abandoned, with some exceptions: Palazzo Palmieri (Monopoli, Italy) is occasionally opened for touristic tours or organized events.

In addition, the approach has been tested in occupied dwellings in West England, UK, which generally suffer from damp and condensation before and after the energy retrofitting. The English case studies, characterized by different constructive techniques, have been retrofitted with the installation of external insulated panels in expanded polystyrene (EPS) (Sierra et al., 2018). In UK, the achievement of sustainability, reduced energy consumption and better indoor comfort is a very real problem (May and Sanders, 2017).

Definitely, the methods to the diagnosis, the equipment and the information exchange tools are different for the nature of building pathologies and damages, and buildings themselves.

In historic masonry buildings (South Italy), the issues are related to static and dynamic equilibrium of the masonry structures; the evident damp patterns are generally connected to water penetration for the aging of materials, the absence or damage of windows and doors, the roofs without a water-proof layer and the growth of spontaneous vegetation that create damaging openings in external walls and roofs.

Accordingly, the diagnostic survey aims at the accurate geometric survey and the identification and qualification of material and constructive techniques, being careful to investigate inaccessible rooms and building components, and identifying structural transformations in the past.

Another relevant step is the evaluation of cracks and deformations patterns, their direction and progression, dimensional parameters (length, width, depth) and the correspondent settling, the quality of masonry, the historical transformations that may be the origin of the detected kinematic movements. The detection of invisible water penetration and raising damp may be executed as well (Table 4.1-1).





| Id. Code | Denomination | Location | Picture | Year of construction | Structure |
|--------------------|-----------------------|-----------------------------|---|--|----------------------|
| SOUTH ITALY | | | | | |
| IT_S_1 | Macchia Trappeto | Giovinazzo, South Italy |  | | Stone bricks masonry |
| IT_S_2 | Masseria Don Cataldo | Adelfia, South Italy |  | Further transformations | Stone bricks masonry |
| IT_S_3 | S. Agostino Monastery | Trani, South Italy |  | Further transformations | Stone bricks masonry |
| IT_S_4 | Bell Tower, Cathedral | Ruvo di Puglia, South Italy |  | Further transformations | Stone bricks masonry |
| IT_S_5 | Palazzo Palmieri | Monopoly, South Italy |  | XVIII century Further transformations | Tuff brick masonry |

Table 4.1-1 Case studies in South Italy.

Whilst, in occupied buildings, the monitoring of internal and external temperature and relative humidity, occupancy and energy consumption is fundamental for understanding the real hygrothermal behaviour of the building and operating adequate actions. In addition, real-time acquisition can provide insights about incorrect design and execution solutions, for example unsolved thermal bridges or inefficient mechanical ventilation. Consequently, a system of real-time monitoring may be provided as integrated with further knowledge.

In this context, the HBIM approach might be implemented with web-based platforms connected with sensor networks installed inside the buildings, and weather station gauging outdoor boundaries. Additional in-situ tests have been conducted in order to detect the mapping of surface temperature, thus the presence of heat losses via heat flux sensors, and air leakage by air permeability test, before and after the installation of External Wall Insulation (EWI). The average method was employed for calculating the thermal transmittance air to air (U-value) according to ISO 9869-1 (BSI, 2014)(Kosmina, 2016).

The foreign case studies have been examined during the visiting period at the University of West England, UK, collaborating within the International project “HBIM project: Smart heritage building performance measurement for sustainability”, with the scope of realizing an open source web-based spatial data management system able to store knowledge about the buildings and providing historical significance, interpretation, transformation over time and performance progression, in the optics of suggesting the coherent intervention. Another sub-objective is disseminating the use of the site as an educational and training tool about key gaps and skills in this field (‘HBIM Portal-Smart Heritage Building performance measurement for sustainability’, 2016).

In the following (Table 4.1-2), the case studies are explained¹⁰.

¹⁰ The HBIM portal project also comprehends Egyptian case studies. They have not been analysed because the collaboration with the UWE University focused on the risk of condensation and mould risk in West England buildings. The initiative involves international institution partners: University of West England, University of Salford, British University of Egypt, Cairo University. The project aimed at proposing and testing methods for smart performance measurement in heritage buildings, for sustainability and heritage preservation purposes (<http://www.hbim.org/>).



| Id. Code | Denomination | Location | Picture | Year of construction | Structure |
|---------------------|--------------------|----------------|--|--|------------------------|
| WEST ENGLAND | | | | | |
| UK_W_1 | Victorian House | Bristol, UK |  | 1890-1903 | Solid walls |
| UK_W_2 | Hassel Drive House | Bristol, UK |  | 1970s | No-fine concrete walls |
| UK_W_3 | Joule House | Manchester, UK |  | 1818 and transformation after II World War | Solid walls |

Table 4.1-2 Case studies in United Kingdom.

4.2 Knowledge structuration and HBIM project execution process map

As illustrated in Section 3.2, in a refurbishment project, the preliminary activity is the organization of the work [OKS] following specific guidelines for the implementation of BIM in projects that suggest the drawing of the Employer's Information Requirements (EIR) and the BIM Execution Plan (BEP) (BuildingSMARTAlliance, 2015)(PAS 1192-3, 2014). Further developments have been conducted by Dwairi and Mahdjoubi, 2016 about innovative approaches and methods for the structuration of the EIR based on the ontology model, in order to acquire the information requirement and translate them into

a common language among all the stakeholders (Dwairi and Mahdjoubi, 2016). As the BEP defines goals and uses of BIM, it reports that the HBIM process for existing building comprehends the following sub-tasks:

- Surveying the building in order to capture geometries and morphologies with a high level of accuracy and detail;
- Representing the “as-is/as-damage” condition of the building, with a high level of accuracy;
- Relating the significance and historic value of the building;
- Collecting knowledge about archival documentation, previous photographs, etc.
- Reconstructing the transformation over time and former interventions;
- Mapping decay patterns and building pathologies;
- Reporting diagnostic and monitoring results for building performance assessment;
- Preparing the model for technical analysis (structural analysis, energy analysis etc.)
- Planning and executing the interventions.

The fulfilment of these and other more specific tasks is supported by building overview process maps, and detailed BIM use process map, continually updated.

Among several methods for mapping process, the BIM Project Execution Planning Guide use the Business Process Map Notation (BPMN). The symbols and annotation are explained in several documentations (Figure 4.2-1)(Messner et al., 2011)(Eastman et al., 2011)(‘National BIM Standard - United States® Version 3, Chapter 5 - Practice Documents’, 2015).

The overview map illustrates the relationship between BIM uses to be employed on the refurbishment project and it is shown in Figure 4.2-2.

The process map reflects the structure of the methodological approach proposed for managing the research, and it is featured by the integration of material-construction characterization and building condition assessment. The process map establishes the

critical information exchanges, related to a specific process or shared between processes and responsible parties. Thus, the Information Exchanges are the BIM deliverables to be employed in consequent processes in order to increase the accuracy of the incremental knowledge about the building and allow the communication and sharing of competences and experiences among the actors of the process. The work team must declare methods to ensure model and knowledge accuracy and comprehensiveness, also agreeing on information management models and standards, such as ontologies, MVD and IFC, to eliminate inconsistencies, redundancies, providing communication protocols and promote interoperability. In the specific circumstances of refurbishment, the setup of export options guarantees a reliable data exchange about geometries in IFC, but an extensive development of the standard is required in order to reach interoperability of information and communication of performance assessment activities (Rio et al., 2013)(Bruno et al., 2018).









| Element | Description | Notation |
|----------------------|---|--|
| Event | An Event is an occurrence in the course of a business process. Three types of Events exist, based on when they affect the flow: Start, Intermediate, and End. |  |
| Process | A Process is represented by a rectangle and is a generic term for work or activity that entity performs. |  |
| Gateway | A Gateway is used to control the divergence and convergence of Sequence Flow. A Gateway can also be seen as equivalent to a decision in conventional flowcharting. |  |
| Sequence Flow | A Sequence Flow is used to show the order (predecessors and successors) that activities will be performed in a Process. |  |
| Association | An Association is used to tie information and processes with Data Objects. An arrowhead on the Association indicates a direction of flow, when appropriate. |  |
| Pool | A Pool acts as a graphical container for partitioning a set of activities from other Pools. |  |
| Lane | A Lane is a sub-partition within a Pool and will extend the entire length of the Pool - either vertically or horizontally. Lanes are used to organize and categorize activities. | |
| Data Object | A Data Object is a mechanism to show how data is required or produced by activities. They are connected to the activities through Associations. |  |
| Group | A group represents a category of information. This type of grouping does not affect the Sequence Flow of the activities within the group. The category name appears on the diagram as the group label. Groups can be used for documentation or analysis purposes. |  |

Figure 4.2-1 Process Mapping Symbols for BIM Process Maps. Source: (Messner et al., 2011).

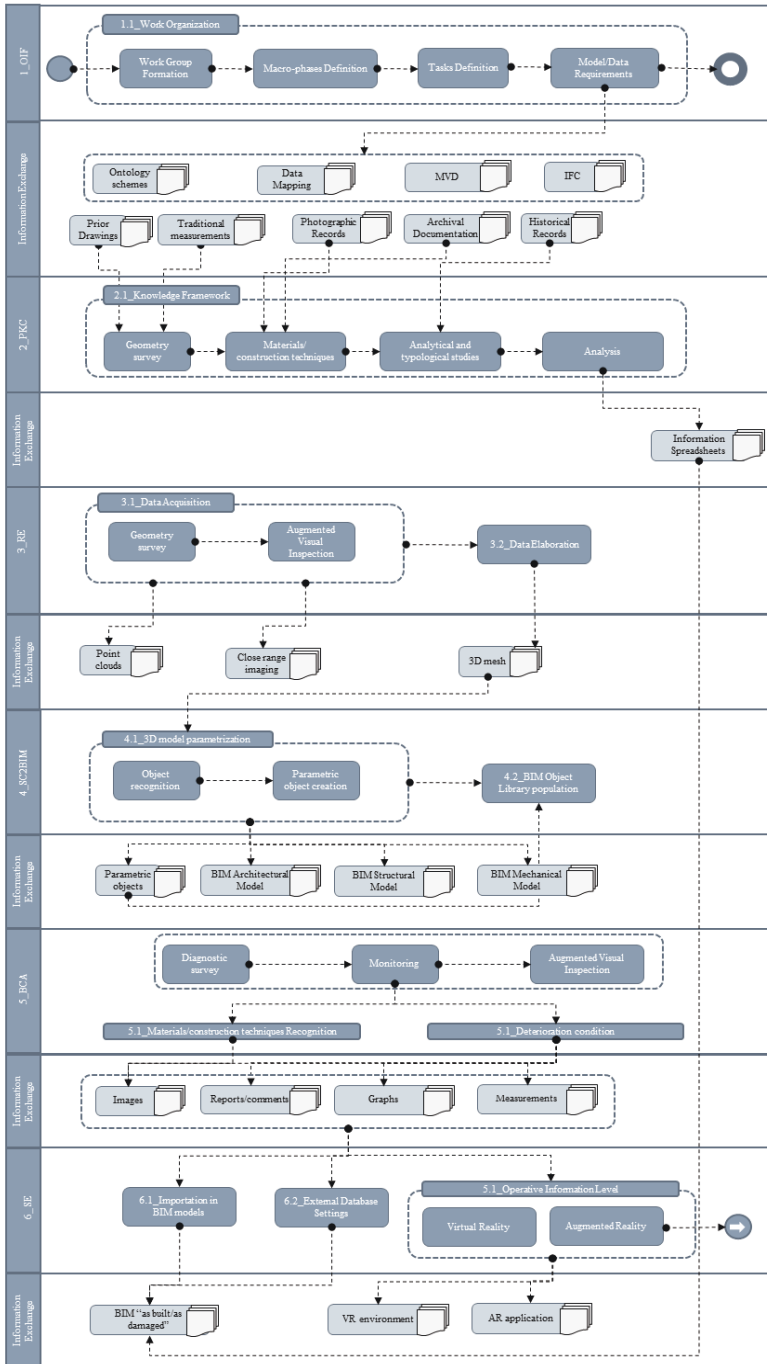

Figure 4.2-2 - Business Process Map Notation for refurbishment.

4.3 Data acquisition and parametric modelling

As explained in Sections 3.3 and 3.4, the methods for geometric survey employed are the hybridization of traditional techniques and photogrammetric data capture. The data capture with photogrammetric survey via UAV has been performed for the Masseria Macchia Trappeto (IT_S_1), because isolated in agricultural landscape (Modugno et al., 2016) (Bruno et al., 2017b).

Masseria Macchia Trappeto (Figure 4.3-1) is a rural building of the 14th century, located in Giovinazzo, Southern Italy. Architectural typology and construction techniques are typical of rustic architectures of mills (or *trappeti*), oil production plants typical of the Apulian agricultural area. The farm has a horizontal development on a single floor, surrounded by walls of high thickness with loopholes, to fulfil defensive functions. The rooms surround an open quadrangular space and include the “*lamia*”, the oil production room, characterized by a barrel vault, the chapel, service rooms and a porch used as a barn. The niches in masonry had been employed as storage in the past. Masonry walls consist of limestone blocks in different size, shape and texture. In particular, masonry of the entrance is regular and made of finished blocks, unlike the ones of production rooms.

The aerial survey has been performed employing the drone APR Phantom 3 4k, FC300XW (3.61 mm) camera model, with a georeferencing system allowing the aerial photo-tagging.

The close-range and aerial photogrammetric acquisition have been executed via a EOS Canon 6D, 24-70mm lens with a focal length of 50mm. In indoor data capture, the flash has been not used in order to avoid different lighting exposure, unfavourable for image matching; the solution has been the setting sensitivity value, maintaining a low ISO in order to avoid additional noise. The outdoor data capture have been performed in diffused light conditions with cloudy sky. The camera installed on a tripod has been employed for the automatic capture of the indoor environments, because the depth of field is required in making photos of interior rooms without flash, which results in little amount of light in the photo-camera, therefore a long shutter time is necessary. Consequently, slight movements of the camera can produce a blurred result.

In the two cases of indoor and outdoor data capture, acquisition plans are required in order to ensure good level of detail with a 60% overlap. In addition, shots about niches, doors and further details have been acquired, with control measurements for scaling the model, after its reconstruction (Figure 4.3-2).

In the indoor acquisition, three elevations of the camera have been planned to capture the entire height of the room.



Figure 4.3-1 Masseria Macchia Trappeto: aerial photo. Source: (Modugno et al., 2016).

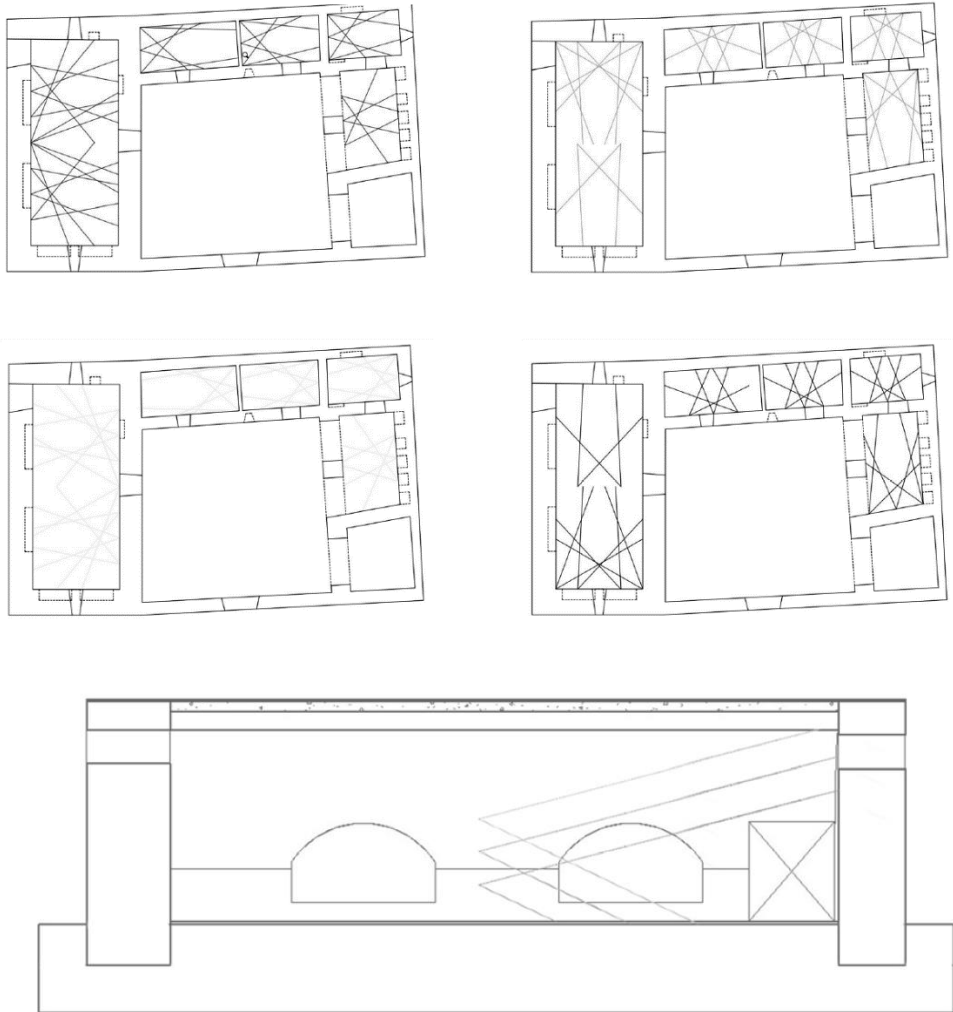

Figure 4.3-2 Masseria Macchia Trappeto: Acquisition plane. Source: (Modugno et al., 2016).

Image processing has been handled through different dedicated software products, interoperable thanks to open standard formats for import/export of point clouds and meshes (respectively i.e *.pts and *.obj). In detail, Agisoft® PhotoScan generates sparse point cloud, dense point cloud and mesh, the last utilized for extracting real texture of building. The set up for data processing has 1) maximum resolution, 2) default Key Point Limit (KPL) - 40.000 pixel - for feature matching in images and 3) default

Tie Point Limit (TPL) for image matching and depth calculation, in order to obtain a satisfactory Sparse Point Cloud, after optimization and in an acceptable time (Figure 4.3-3).

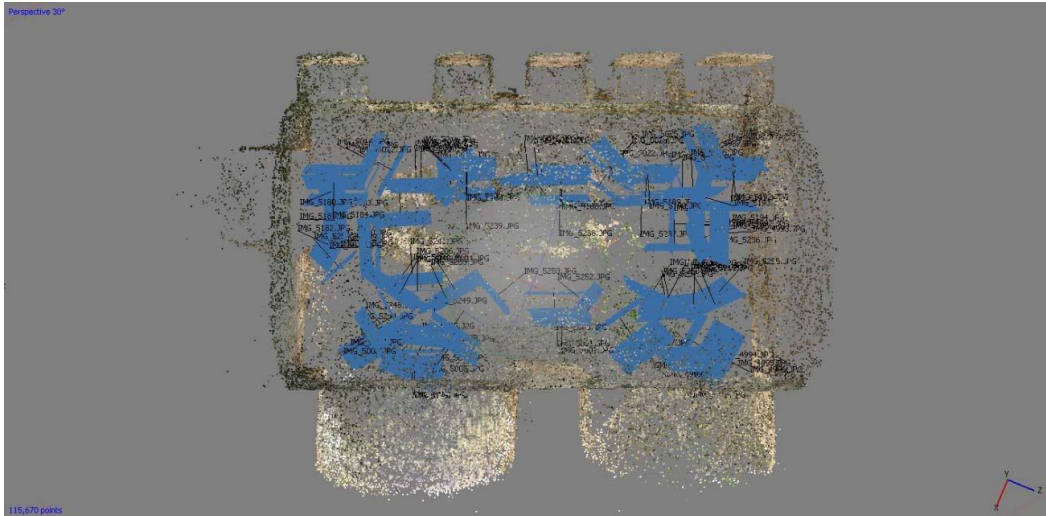

Figure 4.3-3 Masseria Macchia Trappeto: Sparse Point Clouds. Source: (Modugno et al., 2016).

The elaboration of the Dense Point Cloud has been executed with High or Medium quality, in order to obtain a geometric survey in acceptable time and a manageable model. Successively, the Mesh has been processed with the following options:

- Surface Type: Arbitrary because of acquisition of 3D objects;
- Source Data: Dense Point Cloud or Sparse Point Cloud;
- Face Count: the selection of the total number of surface faces (High for medium resolution, and Medium for high resolution), resulting from meshes with a similar number of polygons;
- Point Classes: useful for GIS-based mapping of material classes (vegetation, soil, water, etc.);
- Interpolation: for reconstruction of triangulations without point data.

The last step is the creation of the texture as a photomosaic on the triangulated mesh, using the Mosaic option that selects the closest photo to the corresponding surfaces and uses that image without mixing with other overlapping photos. This is the suitable setting for textures of architectural photogrammetric models. After the model has been

scaled 1:1, using control measurements and markers, the model of the entire building has been generated aligning and merging the chunks of each rooms with the external envelope (Figure 4.3-4).



Figure 4.3-4 Masseria Macchia Trappeto. The entire 3D photo-reconstructed model. Source: (Modugno et al., 2016).

The resulting 3D image-based model has been employed as metric reference for modelling parametric objects. The automatic modelling of walls, vaults and openings was not performed in this case study. The walls present the stratigraphy as inspected in the jambs of damaged openings and windows; the walls are multi-wythe units with internal and external stone brick masonry and inner core with mortar and stones (minimum thickness=1,30 m, maximum thickness=1,60 m).

The barrel vaults have been modelled starting from an adaptive parametric surface, used for generating the vault-related object corresponding to each room. The key parameters are the skew-back and the vault radius (Figure 4.3-5)(Figure 4.3-6). The abutment has been separately modelled, parameterising the height and vault radius. On the top, the pavements have been positioned. The parametric modelling also has interested the niches, windows with “*sguincio*” and openings (Figure 4.3-7). Figure 4.3-8 shows the axonometric cross-section of the building.

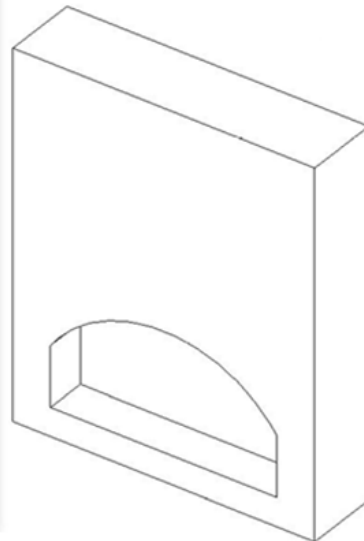
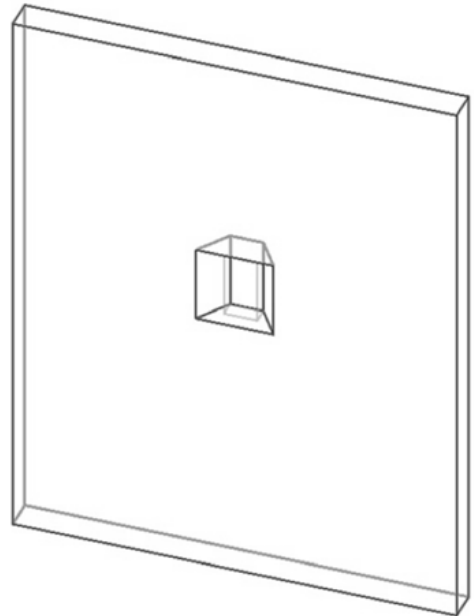

Figure 4.3-7 Masseria Macchia Trappeto. Parametric modelling of openings and niches. Source: (Modugno et al., 2016).

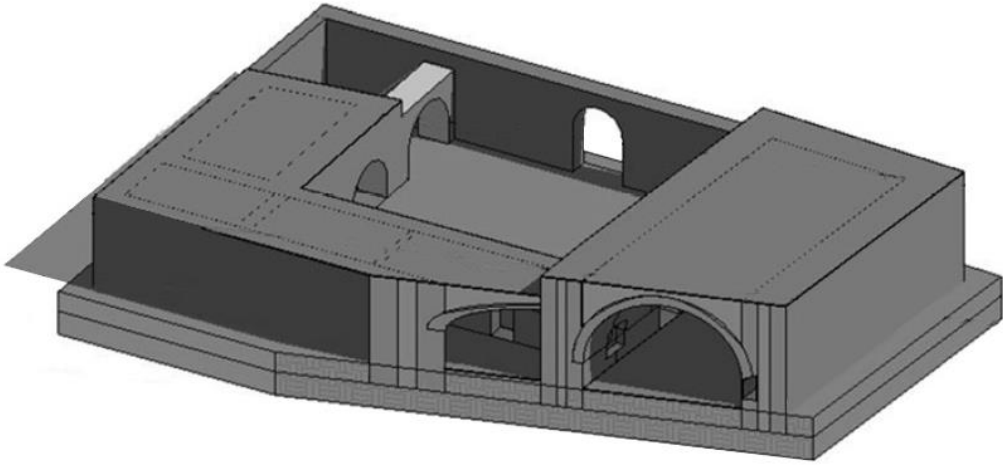

Figure 4.3-8 Masseria Macchia Trappeto. Axonometric cross-section. Source: (Modugno et al., 2016).

The actions for modelling mirror vaults, ribbed vaults and cloister vaults have been different from the ones required for barrel vaults. The regular mirror and cloister vaults (based on rectangular rooms) have been modelled as adaptive parametric objects, employing the sweeping operation starting from a direction line and a generative line. Nevertheless, the typology of buildings analysed presented several irregular vaults (Figure 4.3-9, making possible only the solid methods, in order to achieve higher accuracy. In addition, some vaults are the result of previous partial demolitions and reconstruction.

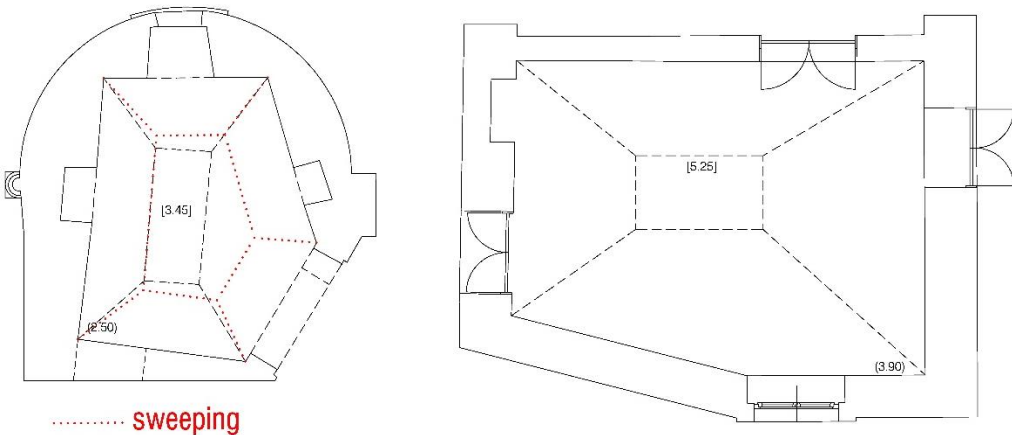

Figure 4.3-9 Irregular mirror vault in Masseria Don Cataldo (IT_S_2) and Palazzo Palmieri (IT_S_5).

In other case studies, the modelling of decorative elements has been necessary (IT_S_2, IT_S_3, IT_S_5). For example, these architectural elements are the gambles and jambs of openings, decorative columns of the entrance (IT_S_5) and the lodges (IT_S_2) that all have specific architectural style dictated by owners purposes.

4.4 Testing the degree of automation in parametric modelling

In Section 2.5, gaps-in-knowledge have been identified in automatic modelling practice. The automation is directly deriving from the streamlined point clouds/mesh segmentation and object recognition. Although several academic experimentations, methods and commercial products have been developed, there is still the need of integrating them for a complete and more accurate automatic modelling. The goal of this research is not the formulation of new algorithms and procedure for automating the modelling, rather the testing of existent methodologies and software tools.

In this section, the automatic modelling of walls have been investigating employing the add-on As-Built for Autodesk Revit© 2018 (2018.0.3.27981), by FARO. This is used for the modelling of geometric primitives of walls, doors, windows, openings, roofs, structural elements and pipes, computing the generative curves that better fit the point cloud. Nevertheless, it is not capable to model vaults, as the other commercial tools. At this scope, the method investigated by Banfi (Banfi, 2016) is a possible way out the issue of generating complex and irregular geometries via NURBS.

The use of the add-on As-Built for Revit© stands on the link of the point cloud in Revit© after the elaboration of point clouds from laser scanning or photogrammetry.

The test is performed on the central hall of Masseria Don Cataldo (IT_S_2), with octagonal plant and a particular and irregular octagonal vault with a plane top (analogy with the “*a schifo vault*” (or mirror vault), conversely based on four sides) (Figure-4.4-1).

This building is a noble artefact built in Adelfia, whose original nucleus dates back to 1719. Today, the feudal residence develops on three levels because of continuous transformations over time, assuming typological characteristics of a fortified structure in masonry load-bearing walls. The selection of this case study is motivated by the

possibility of programming well-managed investigation of an environment with high architectural and cultural value with diagnostic activity in order to identify real degradation effects and causes of anomalies on which intervene, avoiding further damage to the 18th-century decorative apparatus and tempera frescoes. Indeed, the octagonal environment is adorned with degraded tempera frescoes on plaster, belonging to the early nineteenth century, about scenes from the Orlando Furioso. The access to this space occurs through four symmetric and decorated entrance portals, depleted of finely painted 17th-century wooden finishes.

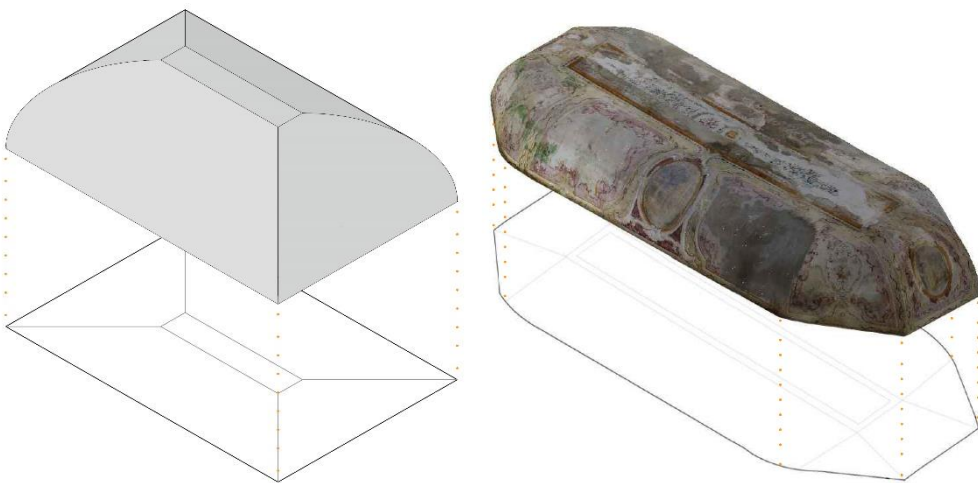

Figure-4.4-1 (a) Mirror vault on four sides (b) Octagonal mirror vault. Source: author.

The geometric survey and the visual inspection of the main hall of Masseria Don Cataldo have been carried out on 4th November 2016. The first step of the close range photogrammetric survey consists of the study of the object/space to be captured in order to advance a capture plan, after the evaluation of the effective feasibility of this technique in the current conditions. This technique has been employed because of the appreciable accuracy of this geometric survey against the laser scanning, employing less expensive equipment (a photo-camera). In addition, the textures of the objects are distinguishable, guarantying good matching and overlapping of images.

The capture plan is based on the parallel axis procedure, with a side overlapping of the multiple stereo couples of 65%, and more than 80% of forward overlap. The equipment

the possibility of working with chunks and to iterate the process starting from the generation of a Sparse Cloud, a Dense Cloud and a Mesh Model, setting different levels of processing efforts.

In addition, the interoperability between different authoring software has been validating, because of the export of *.pts file from Agisoft Photoscan readable from the Revit© Autodesk platform, after the indexing of the raw format in a Revit compatible one (*.rcp). Before the import of the point cloud in Revit, it has been elaborated for cleaning the noise, outliers and irrelevant points. As expected, the edge of the openings are not well acquired because the photos interested only the hall, missing the thickness of doors and walls. In addition, despite the sky was cloudy, the windows have been incorrectly surveyed.



Figure 4.4-3 3D photo-reconstruction in Autodesk Remake. Source: author.



Figure 4.4-4 3D photo-reconstruction in Agisoft Photoscan. Source: author.

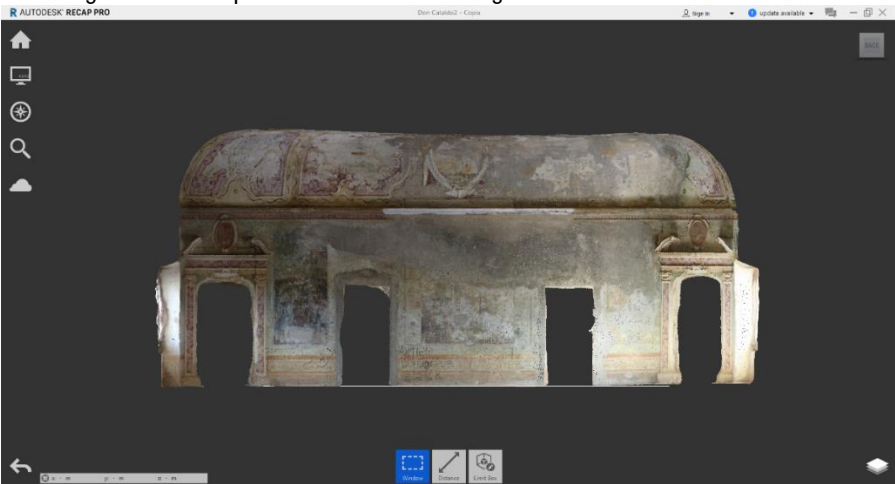

Figure 4.4-5 3D photo-reconstruction in Autodesk ReCap. Source: author.

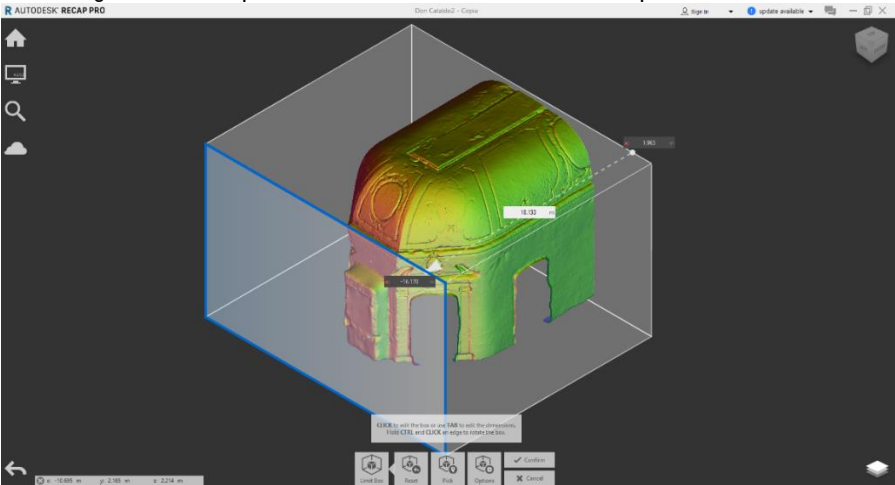

Figure 4.4-6 3D mapping according to the vector direction. Source: author.

The subsequent step regards the parametric modelling and the testing of the degree of automation. In this regard, after the insertion of the point cloud in the BIM modeller tool, the As-built for Revit by FARO - that works with point clouds by laser scans and 3D photo-reconstruction - has been tested. It generates the best fitting building components (walls, doors, windows, pipes, openings, structural elements) and provide the calculation of the deviation values between the BIM model and the point cloud.

The adequate Level of Accuracy is selected according to the Level Of Accuracy (LOA) Specification Version 2.0, written by the US Institute of Building Documentation (<http://usibd.com>) and the national convention (i.e. in Italy, the UNI 11337-4:2017 that provides a specific system of Level of Development for refurbishment and restoration, introducing LOD F and LOD G).

The typical representation scales in Cultural Heritage field, that influence the Level of Geometry and Accuracy, are resumed in Table 4.4-1:

| Scale | $\epsilon (0.2 * n)$ | $T(\epsilon * 2/3)$ |
|-------|----------------------|-----------------------|
| 1:1 | 0.2 mm | $\pm 0.4 \div 0.6$ mm |
| 1:2 | 0.4 mm | $\pm 0.8 \div 1.2$ mm |
| 1:5 | 1 mm | $\pm 2 \div 3$ mm |
| 1:10 | 2 mm | $\pm 4 \div 6$ mm |
| 1:20 | 4 mm | $\pm 8 \div 12$ mm |
| 1:50 | 1 cm | $\pm 2 \div 3$ cm |
| 1:100 | 2 cm | $\pm 4 \div 6$ cm |
| 1:200 | 4 cm | $\pm 8 \div 12$ cm |

Table 4.4-1 Typical representation scales in Cultural Heritage field and accuracy. Source: (USIBD, 2016).

The representation scale can be 1:50 for floors, elevations and sections with a Level of Detail (LOD) 500, correspondent to the Italian LOG G. The analogue Level of accuracy is LOA20, with a upper range of 5 cm and a lower range of 15 mm (confidence level of 95%) (Table 4.4-2).

| Level | Upper range | Lower range |
|--------------|--------------------|--------------------|
| LOA10 | User defined | 5 cm* |
| LOA20 | 5 cm * | 15 mm* |
| LOA30 | 15 mm* | 5 mm* |
| LOA40 | 5 mm* | 1 mm* |
| LOA50 | 1 mm* | 0* |

**specified at the 95 percent of confidence level*

Table 4.4-2 Five defined Levels of Accuracy. Source: (USIBD, 2016).

The test is performed on the same main hall, employing LOA50 as USIBD scale, (as-built representation) considering two set of calculation with the “maximum surface distance-MSD”: (1) 50.00 mm; (2) 300.00 mm (ANNEXANNEX A). The maximum surface distance consists of the buffer around the cut surface, in which point cloud should be considered for the deviation analysis.

The choice of computing the deviation with these different parameters stands on the evidence that the real walls of the room have out of plumb and irregular surfaces, due to the presence of detached or spalling plaster, leaving discovered the masonry structure of stone bricks. Consequently, it is expected a major deviation between the parallelepiped wall and the point clouds, even if the software can best fit the points.

In addition, the decorations of openings have not been modelled in this phase. The results of the both cases (1) and (2) consists of the evaluation of four parameters, visually explained in Figure 4.4-7 (FARO, 2018):

1. *Average Value: The average distance between all point cloud points in this cell.*
2. *Minimum Value: The smallest absolute deviation within the grid cell. Positive values lie outside.*
3. *Maximum Value: The largest absolute deviation within the grid cell. Positive values lie outside of the component, negative values inside of the component.*
4. *Nearest Value - The distance used is that of the point that when projected onto the surface is closest to the centre of the grid cell.*
5. *Number of Points: The number of all of the points found in this cell.*

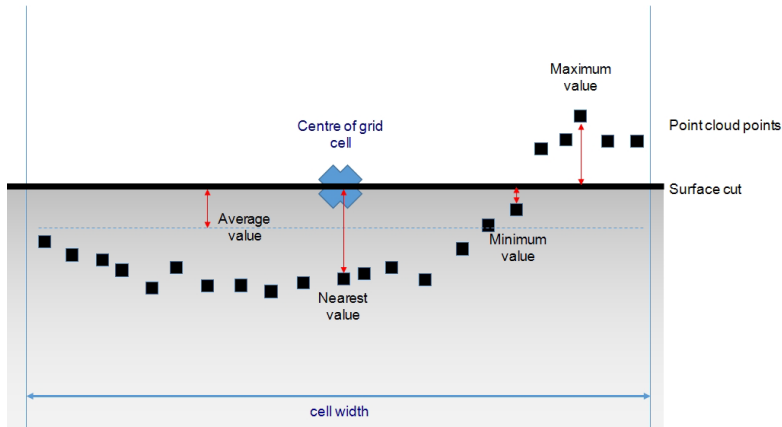

Figure 4.4-7- Graphical explanation of parameters of deviation evaluation. Source (FARO, 2018).

4.5 Semantic enrichment

The information, handled within each parameter object, regards historical notes, characterization of materials (physical-mechanical properties), degradation status, and selected refurbishment actions, for accomplishing defined technical-performance requirements. Additionally, the model reports pathologies and settlements as parametric objects in order to visualize and quantify surfaces and volumes on which to intervene.

The buildings of Southern Italy have masonry walls with structural function, being load-bearing multiple-wythe masonry, consisting of internal and external wythes in limestone blocks, and inner core in stones and mortar. The English buildings present load-bearing solid walls in clay bricks or pre-casted no-fine concrete walls.

4.5.1 Modelling and management of decay patterns

Some of the methods illustrated in Section 3.5.1 for decay mapping have been introduced and tested. The use of drawings in 2D view extracted from the 3D model does not allow the semantic enrichment; actually the addition of customized parameters is not available in the annotation object (Modugno et al., 2016)(Bruno et al., 2017b)(Chiabrando et al., 2017). For this reason, the decay-related attributes have been attached to the correspondent building component (wall, door, floor, roof, etc.),

after representing decay pattern via 2D detailing. The area computed by the region object has been manually added to the building component object. The regions have been semantically enriched with detailed photos about the damage/building pathology (Figure 4.5-1, Figure 4.5-2).

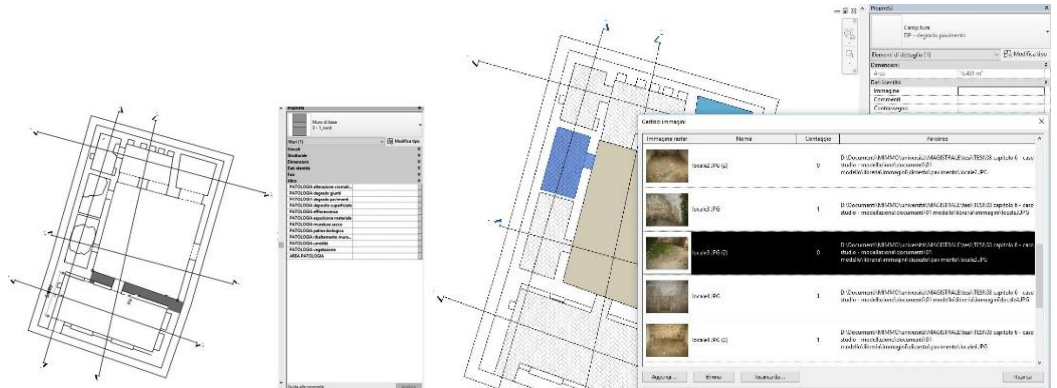

Figure 4.5-1 Masseria Macchia Trappeto: Decay mapping and semantic enrichment.

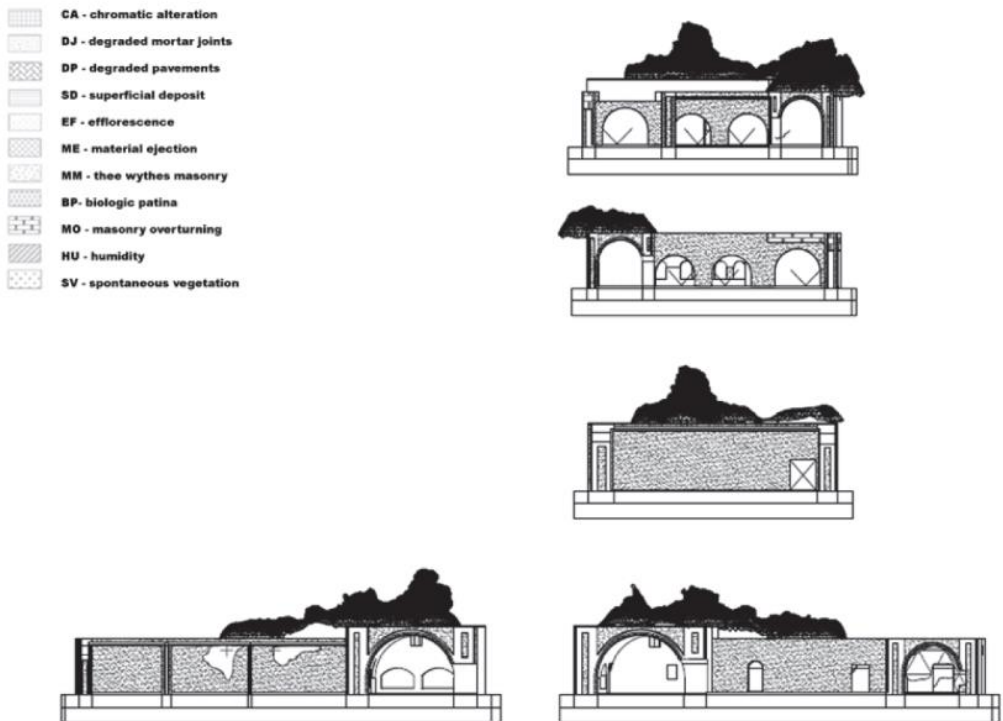

Figure 4.5-2 Masseria Macchia Trappeto: Decay mapping in 2D views extracted from 3D model.

The other method consists of the segmentation of point clouds or meshes and conversion into 3D objects. The segmented portion is converted in contour-lines in Rhinoceros® (ExtractMeshEdge), or the mesh is transformed in NURBS (MeshToNURBS). The .dxf is imported into a generic model family; the area value, as calculated by Rhinoceros, is manually added as object parameter. Successively, the object has been located in the model (Figure 4.5-3). The insertion of customized parameters has permitted the automatic generation of schedules and quantities about the damage and decay phenomena, intervention and cost estimation (Figure 4.5-4).

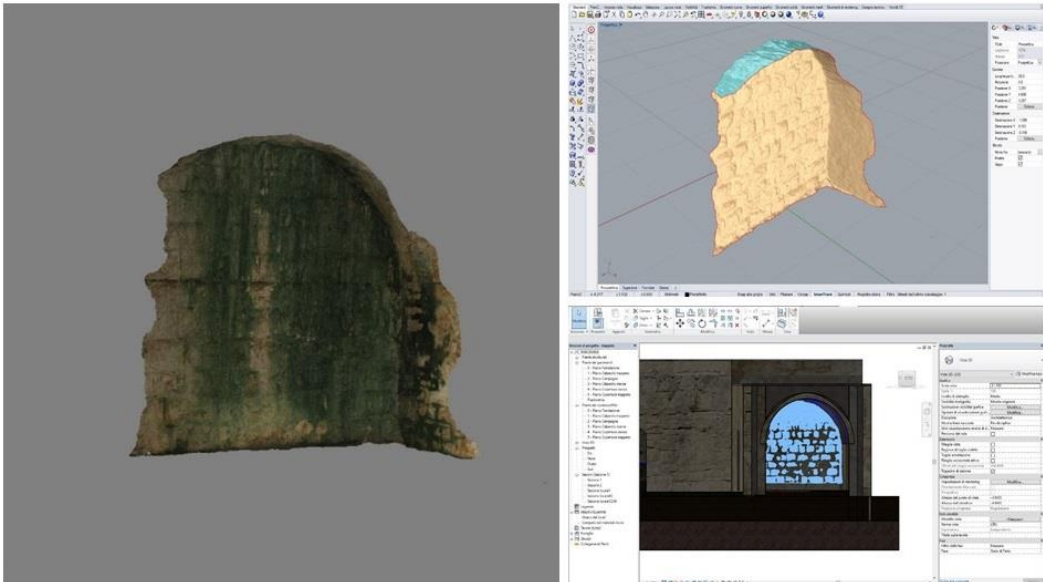

Figure 4.5-3 Mesh segmentation, conversion in NURBS and generation of related BIM object.

| <Diffuse pathologies - copertura> | | | | | | |
|-----------------------------------|--------------------------|-----------------------|------------------------------|-----------------------------|-------|-----------|
| A | B | C | D | E | F | G |
| Nome | Famiglia e tipo | Immagine | Descrizione | Intervento | Costo | Area |
| Tetto di base: copertura | | | | | | |
| D/P - Degraded pavements | Tetto di base: copertura | copertura 01.JPG | Degradation due to the tot | Removal with the recover | 45.00 | 154.80 m² |
| D/P - Degraded pavements | Tetto di base: copertura | copertura 01.JPG | Degradation due to the tot | Removal with the recover | 45.00 | 130.59 m² |
| D/P - Spontaneous vegetation | Tetto di base: copertura | copertura 01.JPG | Presence of plants | Phyto-poison injecting insi | 5.11 | 154.80 m² |
| D/P - Spontaneous vegetation | Tetto di base: copertura | copertura 01.JPG | Presence of plants | Phyto-poison Injecting insi | 5.11 | 130.59 m² |
| Tetto di base: volta1 | | | | | | |
| D/P - Chromatic alteration | Tetto di base: volta1 | volta - locale1.JPG | Natural variation of the ori | Mechanical cleaning of inc | 52.00 | 119.34 m² |
| D/P - Degraded mortal joint | Tetto di base: volta1 | volta - locale1.JPG | Degradation due to erosio | Embossed stitching of join | 24.53 | 119.34 m² |
| D/P - Superficial deposit | Tetto di base: volta1 | volta - locale1.JPG | Degradation due to chemic | Cleanup of surfaces affe | 52.00 | 119.34 m² |
| Tetto di base: volta5 | | | | | | |
| D/P - Chromatic alteration | Tetto di base: volta5 | volta - locale5.JPG | Natural variation of the ori | Mechanical cleaning of inc | 52.00 | 33.70 m² |
| D/P - Degraded mortal joint | Tetto di base: volta5 | volta - locale5.JPG | Degradation due to erosio | Embossed stitching of join | 24.53 | 33.70 m² |
| D/P - Superficial deposit | Tetto di base: volta5 | volta - locale5.JPG | Degradation due to chemic | Cleanup of surfaces affe | 52.00 | 33.70 m² |
| Tetto di base: volta234 | | | | | | |
| D/P - Chromatic alteration | Tetto di base: volta234 | volta - locale234.JPG | Natural variation of the ori | Mechanical cleaning of inc | 52.00 | 81.99 m² |
| D/P - Degraded mortal joint | Tetto di base: volta234 | volta - locale234.JPG | Degradation due to erosio | Embossed stitching of join | 24.53 | 81.99 m² |
| D/P - Superficial deposit | Tetto di base: volta234 | volta - locale234.JPG | Degradation due to chemic | Cleanup of surfaces affe | 52.00 | 81.99 m² |

Figure 4.5-4 Masseria Macchia Trappeto: Scheduling of interesting attributes related to decay and building pathologies.

Similarly, the mesh has been segmented and converted into edges for decay mapping of Masseria Don Cataldo. The selection of the decay phenomena (frescoes decay) has been executed with z-painting for mesh manual segmentation in Meshlab®; the software tool also provides the measurement of areas (Figure 4.5-5).

The segmented meshes have been transformed into surfaces in Rhinoceros©, then imported into Revit© .rfa, and manually localized in the model (Figure 4.5-6). The related object can be semantically enriched including parameters for describing the decay (area, image, etc.), to be handled as schedules.



Figure 4.5-5 Segmentation of the mesh.

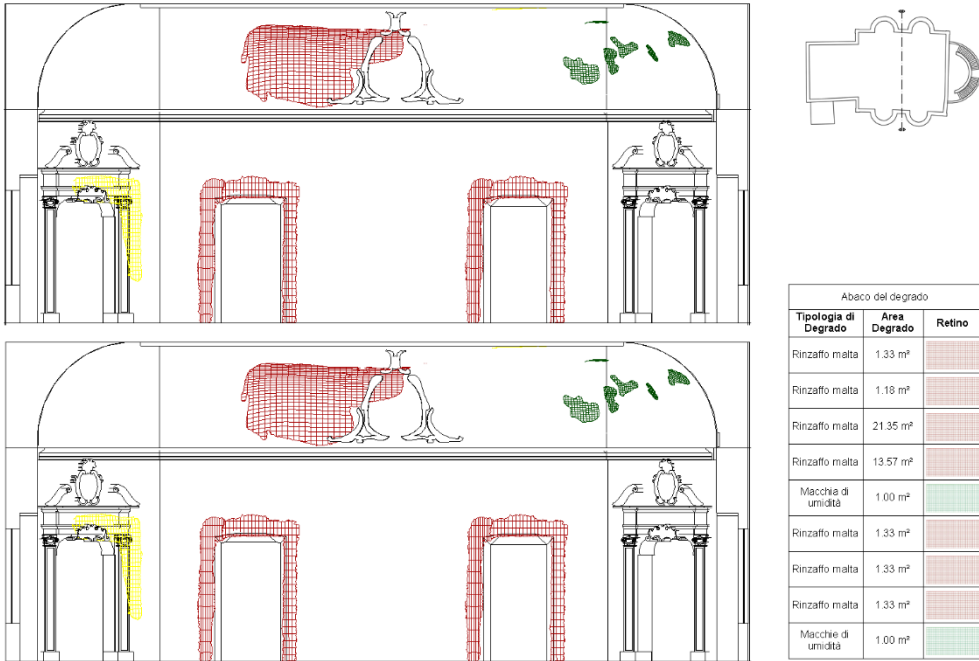

Figure 4.5-6 Decay mapping via extracted edges in 2D views.

Another attempt for decay mapping is employing CAD drawings or photos for sketching decay pattern in 3D generic models, as tried in S. Agostino Monastery, Trani (3D object) and Masseria Don Cataldo (2D detailing).

The Augustinian Monastery (IT_S_3)(Trani, South Italy) was initially built in the 16th century. Afterwards, it has been recurrently transformed and expanded with demolitions, reconstructions, structural interventions and functional upgrading between 1809 and 1960. Currently, the building is featured by heterogeneous constructive systems and degraded conservation status. Three different constructive macro-components are distinguishable (Figure 4.5-7):

1. Unit 1 (1530): six rooms on the first floor and four larger spaces on the ground floor, built by Augustinian monks;
2. Unit 2 (1640): six basement rooms and the corresponding ground floor;
3. Unit 3 (1754 -1757): elevation of the Unit 2 and the completion of the cloister and the surrounding rooms. After the abandonment in 1969, structural improvements of foundations, roofs, façades have been executed because of severe settlements, not

yet completely solved. In particular, foundation piles have been created to solve the settling of primary rotation of the external façades, caused by heterogeneous foundations and soil, as detected in 1992. But, the settling is more complex where the units around the cloister. In addition, the demolition of some vaults replaced with hollow-core concrete slabs has interrupted the static equilibrium. Furthermore, there is a structural disconnection between the 18th-century porch (Unit 3) and the 16th-century unit (Unit 1) and this is a contributory cause of the settling. The corroded rebar of the concrete joist were rehabbed and the hollow-core concrete slabs consolidated by Fiber Reinforced Polymer (FRP) at the intrados (Fabozzi, 2007).

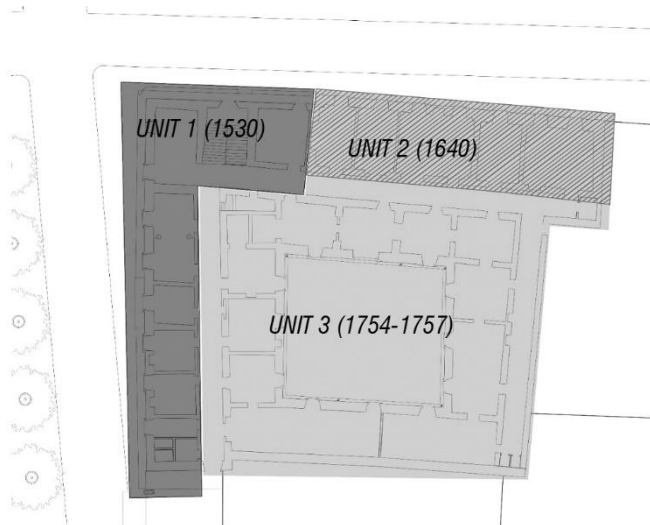

Figure 4.5-7 S. Agostino Monastery: transformation over time and constructive-macro elements. In the case study S. Agostino Monastery, the use of external databases allowed the Information Management of the “as is/as-damaged” HBIM model, in order to support the identification of occurring damages and building pathologies caused by former transformation and interventions. Indeed, Excel spreadsheets are linked to the geometric HBIM model via ODBC Driver in Navisworks Manage© Autodesk (Figure 4.5-8). These spreadsheets have been *ad-hoc* created or exported from the Revit model through the database management tools (i.e. the Ideate BIM link plug-ins, Revit DB link, and the export tools embedded in the software).

The DataBase Management in BIM tools automatically exports ODBC Databases.

The added information concerns technical properties of the building components within the different constructive macro-elements and historical/analytical features (Table 4.5-1), previous interventions (Table 4.5-2) and description of crack patterns (Table 4.5-3).

| Parameters | Description | Data type |
|-------------------------------|---|------------------|
| Construction phase | Year of constructive macro-component (Unit 1, Unit 2, Unit 3). | NUMBER |
| Number of levels | Number of floors in the macro-component. | NUMBER |
| Maximum height at the eaves | Dimension expressed in metres. | NUMBER |
| Minimum height at the eaves | Dimension expressed in metres. | NUMBER |
| Average covered surface | Dimension expressed in square metres. | NUMBER |
| Volume | Dimension expressed in cubic metres. | NUMBER |
| Number of rooms | Number of rooms that composes the constructive nucleus. | NUMBER |
| Use | Use of the rooms that composes the constructive nucleus. | NUMBER |
| Horizontal structural systems | Constructive system of horizontal structural systems (technical typology of vault, slab, etc.). | MULTILINE TEXT |
| Vertical structural systems | Constructive system of vertical structural systems (wall). | MULTILINE TEXT |
| Typology of structural system | Description of structural system. | MULTILINE TEXT |
| Roof | Typology of roof. | MULTILINE TEXT |
| State of conservation | Comments about the state of conservation based on visual inspection. | MULTILINE TEXT |
| Last use | Indication of the last designated use of the building. | MULTILINE TEXT |
| Crack pattern (X) | Crack pattern description about morphology of a crack patterns related to the constructive nucleus (X=1,2,3). | MULTILINE TEXT |

| | | |
|-----------------------------|--|----------------|
| Visual appearance | Description about the visual appearance of crack patterns. | MULTILINE TEXT |
| Settlement (X) | General description of the settlement related to CP(X). | MULTILINE TEXT |
| Causes settlement (X) | Description of the causes of settlement (X). | MULTILINE TEXT |
| Scaffolding | Typological and material description of scaffolding in the constructive macro-element. | MULTILINE TEXT |
| Previous interventions list | List of occurred interventions to constructive macro-element. | MULTILINE TEXT |
| Intervention 1992 | Description of the intervention. | MULTILINE TEXT |
| Intervention 2007 | Description of the intervention. | MULTILINE TEXT |

Table 4.5-1 Parameters about technical properties of constructive macro-components.

| Parameters | Description | Data type |
|-------------------------------|---|------------------|
| Year of intervention | The year of construction of the nucleus. | NUMBER |
| Accessibility by inspection | Possibility of inspection of the intervention. | MULTILINE TEXT |
| Typology of intervention | Description about typology of intervention. | MULTILINE TEXT |
| State of conservation | Comments about the state of conservation based on visual inspection. | MULTILINE TEXT |
| Settlement prior intervention | Description of Settlement (X) related to CP(X). | MULTILINE TEXT |
| Causes of intervention | Description of the motivation for Settlement (X). | MULTILINE TEXT |
| Description of intervention | Description of intervention (phases, materials, constructive techniques). | MULTILINE TEXT |
| Piles foundation system | Material and dimensional composition of piles foundation. | MULTILINE TEXT |
| Source of file | Indication about source of files and information. | MULTILINE TEXT |

Table 4.5-2 Parameters about previous interventions.

| Parameters | Description | Data Type |
|------------------------|--|-------------------|
| Encoding host | Code of constructive element where the cracking is identified. | MULTILINE TEXT |
| Crack pattern typology | Typology of the crack pattern. | MULTILINE TEXT |
| Settlement | Description of settlement. | MULTILINE TEXT |
| Cause of settlement | Description of the causes of settlement. | MULTILINE TEXT |
| Crack length | Dimension measured in three directions. | MULTILINE TEXT |
| Crack depth | Measured depth of the cracks. | NUMBER |
| Crack maximum width | Measured maximum width of the cracks. | NUMBER |
| Crack description | Morphological description of the crack (vertical, horizontal, parabolic shape, etc). | MULTILINE TEXT |
| Crack progression | Indication about the progress of the cracking. | MULTILINE TEXT |
| Profile edgings | Indication of visual appearance. | MULTILINE TEXT |
| Monitoring system | Indication about monitoring activities. | MULTILINE TEXT |

Table 4.5-3 Parameters about crack patterns description.

The access of DataBase Management Systems (DBMS) within the Datatools plug-in depends on the configuration of the database via ODBC Driver within the Application Program Interface (API) in Navisworks. The relational databases underpin the information system via the Structured Query language (SQL), as it is the API for the Relational DataBase Management Systems (RDBMS). SQL statements are employed for interactive queries of information from a relational database and for gathering data for reports.

The SQL string `SELECT*from[Properties$]wherw"Element ID"=%prop("Element ID","Value")` matches the external database to the object in the model, the data fields correspond to the properties shown in the tables automatically created.

This Information System technology supports actors in two possible information management methods: i) the selection of building constructive groups (Unit 1, Unit 2 and Unit 3) and the opening of the related properties table or ii) the use of conditional query operations to filter categories and properties and comparing corresponding values. The first method permits the view of all the information related to an object or to a group, the second one helps the filtering of the required properties per each category and the comparison of the values for specific analysis (i.e. diagnosis of a settlement).

Indeed, the selection of a BIM object in the elements group about the artifact built in 1530 shows the properties table about the category "Analysis of the conservation state A_2017", reporting information about geometry, constructive techniques, interventions and transformations, crack patterns and settlements.

The second method consists of the selection of the specific property correlated to the element, highlighted in the model. The query operation filters multiple data to be compared: the comparison of the detected settlements in each construction unit, the morphology of the cracks, and the motivation of the consolidation intervention.

The query of the database highlights the presence of the same settlement in the three construction units: primary rotation of the external facades and this kinematic movement caused the depression of keystone of the vaults of adjacent rooms (Figure 4.5-9).

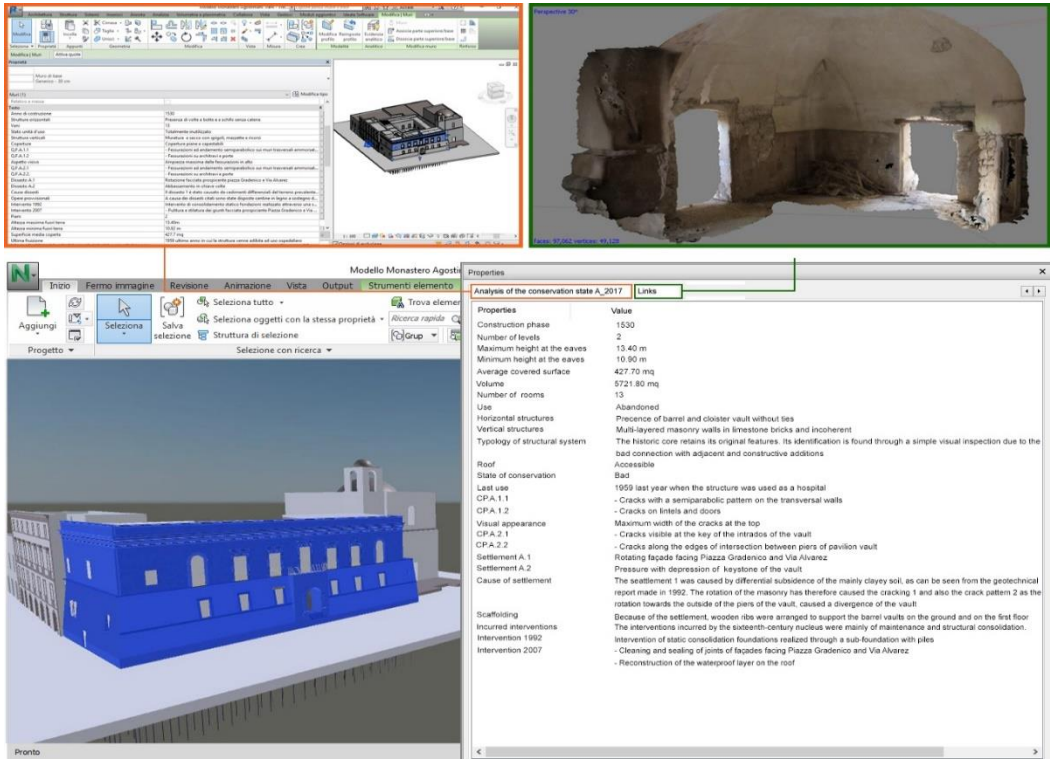

Figure 4.5-8 Integrated BIM database. Source: (Musico, 2017).

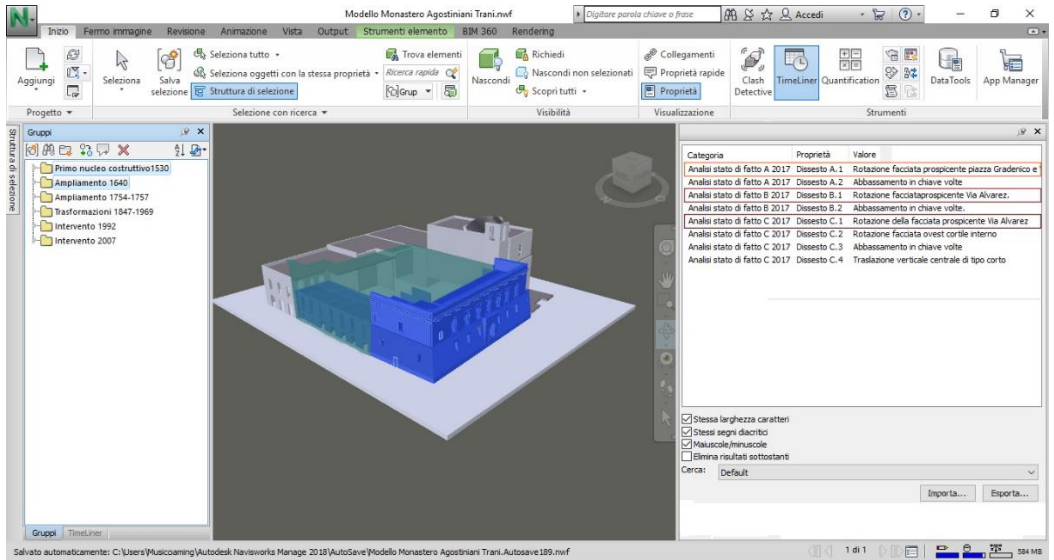

Figure 4.5-9 Selection of categories, property to be analysed, query and property value of the tree units. Down the cracking pattern of three rooms of the building, two on the ground floor (a)Unit 1 and (b)Unit 2, and one on the first floor (c)Unit 3.

4.5.2 Image processing for automated decay mapping

In addition to the above-illustrated methods, the automatic extraction of cracks and decay pattern can be performed using image processing filters from ortho-images, textures or rectified images or spatial and morphological filters for surface analysis employing three-dimensional photogrammetric models (Galantucci et al., 2018). In this work, the edge detection is employed for identifying contours of cracks in images with Sobel and Canny operators in the main staircase of S. Agostino Monastery, Southern Italy. The 2D image is extracted by the texture obtained from the photogrammetric model with a ground resolution of 0,994 mm/pixel, a good resolution for detecting the smallest crack. The Test 1 used the chain of two Sobel operators on the picture 8 bpp

(2135x 1421 pixel), filtered with greyscale. The three chrominance (colour) components are set up on Cr=0, Cg=1, Cb=0. The results of Test 1 (Figure 4.5-10) are shown in Figure 4.5-12 and Figure 4.5-13.

Then, the chain Test 2 with application of Canny operator and Sobel operator (Figure 4.5-11) has been run (Figure 4.5-14 and Figure 4.5-15). The Test 2 provides more sharp edges than the Test 1, for this reason it has been employed for creating the BIM object about the crack.

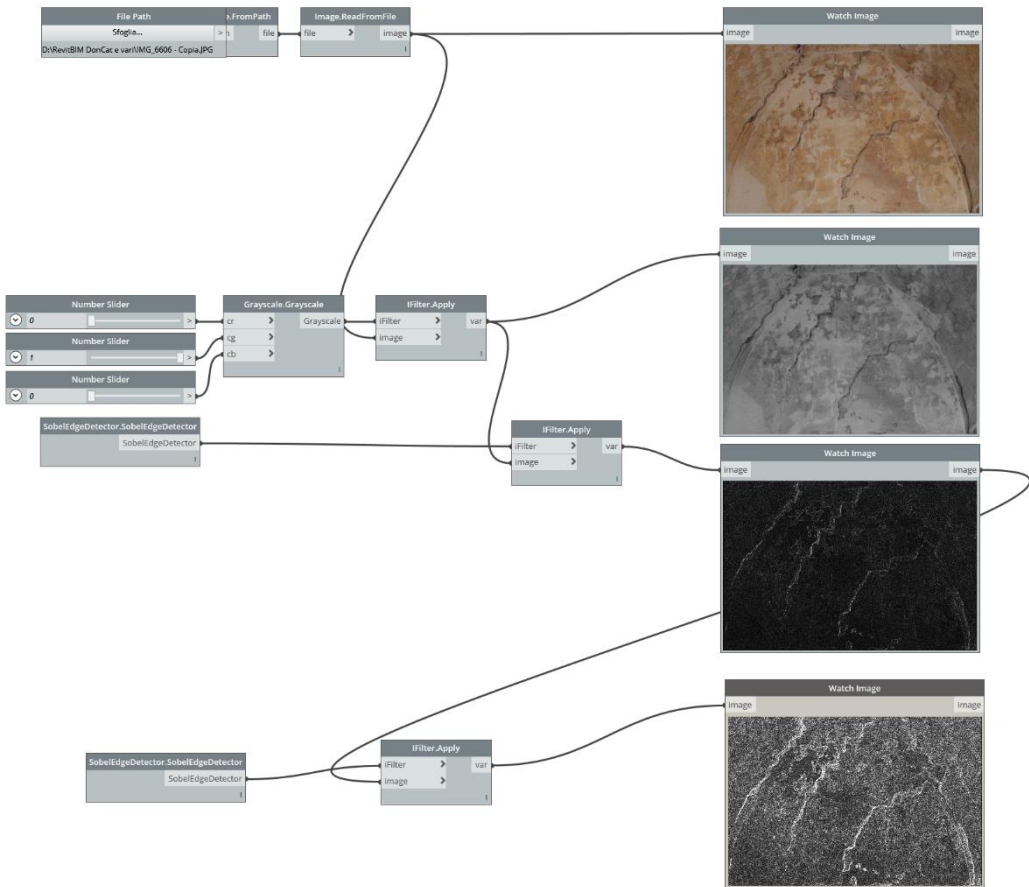

Figure 4.5-10 Test 1 Sobel-Sobel filters: Dynamo algorithm. Source: author.

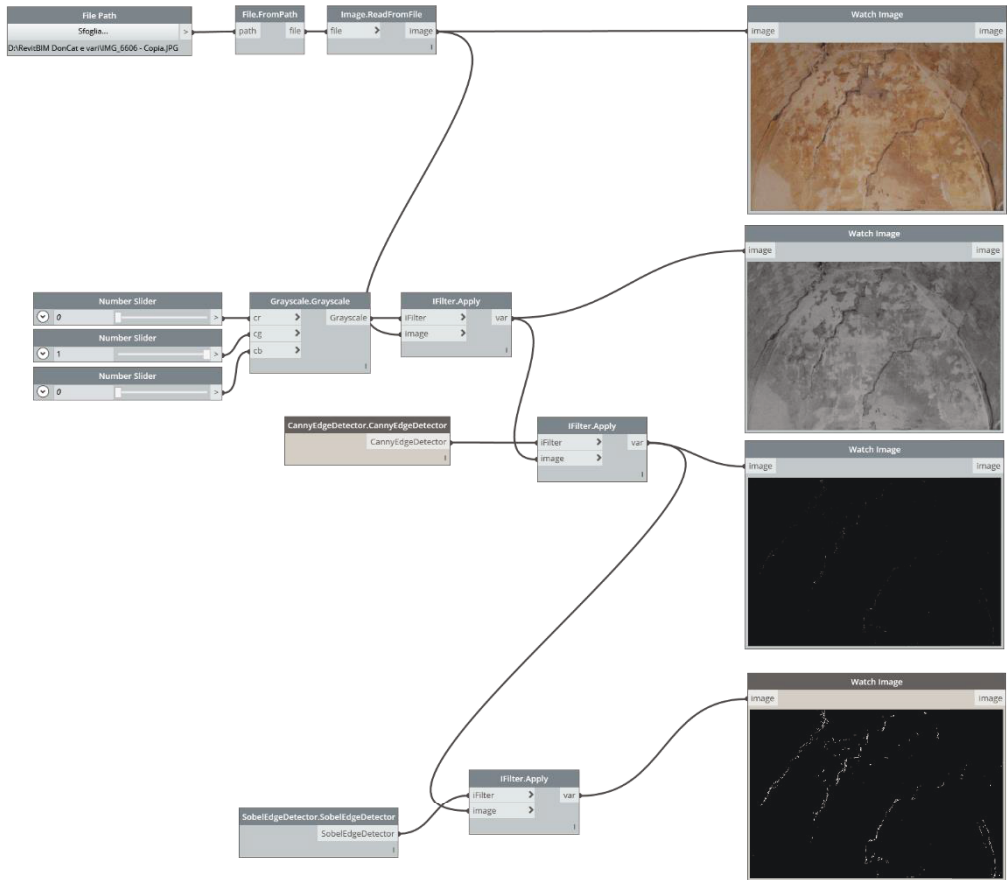

Figure 4.5-11 Test 2 Canny-Sobel filters: Dynamo algorithm. Source: author.

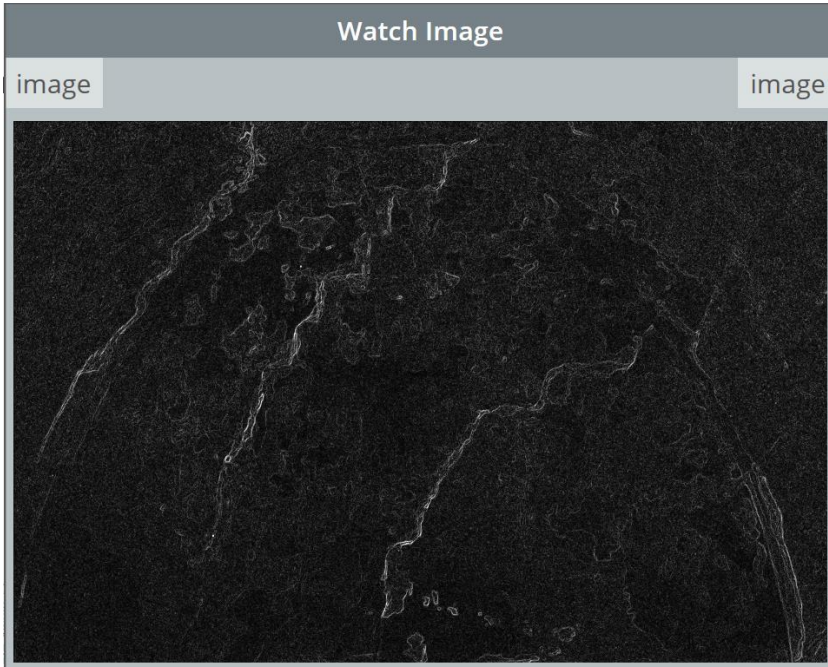

Figure 4.5-12 Test 1 run with Sobel-Sobel filters: step 1 Sobel. Source: author.

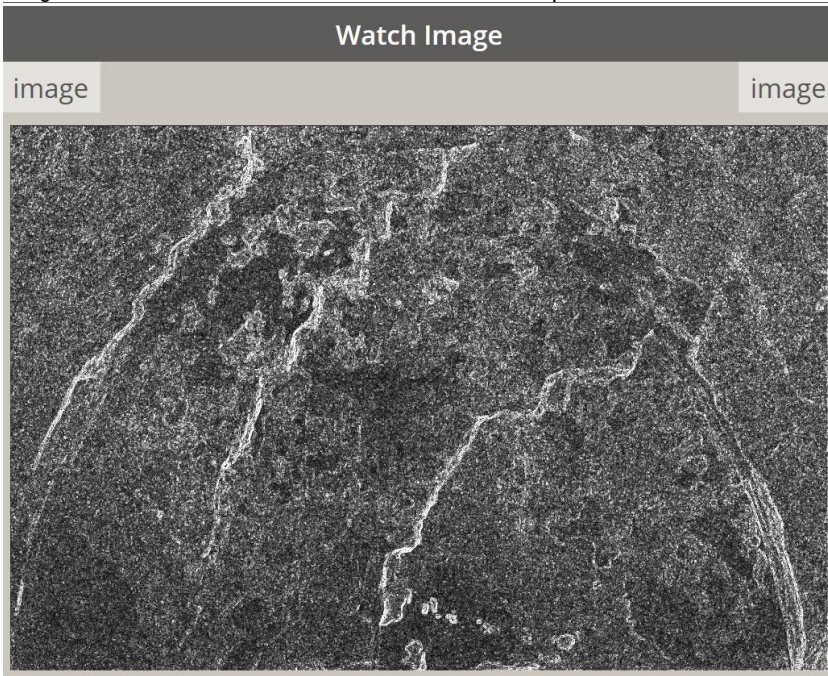

Figure 4.5-13 Test 1 run with Sobel-Sobel filters: step 2 Sobel. Source: author.



Figure 4.5-14 Test 2 run with Canny-Sobel filters: step 1 Canny. Source: author.

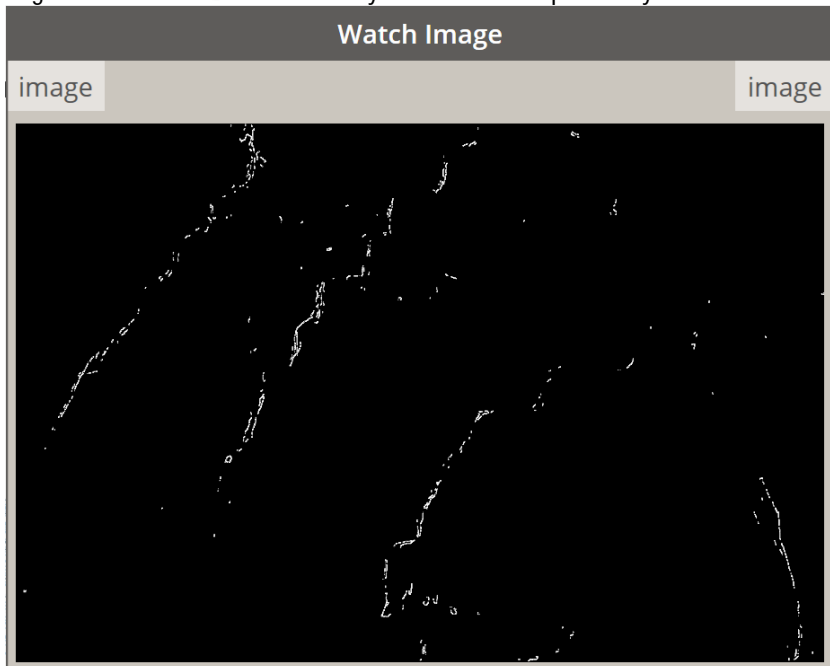

Figure 4.5-15 Test 2 run with Canny-Sobel filters: step 2 Sobel. Source: author.

Then, the detected pixels are converted in coordinated points (x,y,z) and connected via convex hull operator in order to generate polylines and the BIM object to be employed as 2D detailing component (Figure 4.5-16).

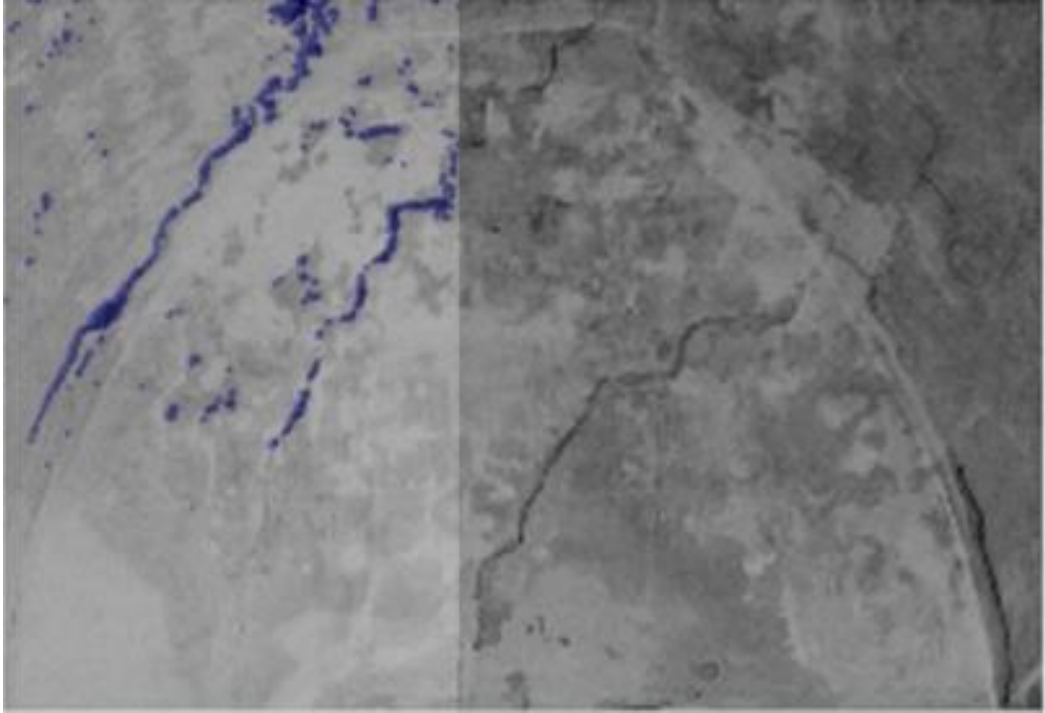

Figure 4.5-16 Crack detected and overlapping on the original image. Source: author.

4.6 File-based management of diagnostic surveys

The Section 2.5.1 discusses open issues about methods and strategies to retrieve diagnostic data for accurate and complete results (Cho et al., 2015). The model must actually respond if questioned about features of the real artefact, looking for fidelity to the original where necessary and using simplifications where possible, without obviously affecting the BIM logics. The BIM model should be employable for managing diagnostic results; in addition to the possibility of generating traditional data and documents, such as floors, elevations, sections, schedules and calculations, the model can be used for further analysis. In the optics of actors working with BIM maturity Level 2, the storage and delivery of files and digital documentation, attached to the master model, is a general practice.

The objective has been tested in two different way: attaching .pdf reports or inserting attributes about metadata (images, comments, method of execution, etc.) within the BIM object of acquisition profiles of the survey. The first method has been executed for documenting georadar and thermography in the main hall of the Masseria Don Cataldo. Stratigraphy and degradation status of masonry walls (thickness 0.70 m) of the main hall have been investigated. The GPR acquisitions were carried out on the west masonry, employing a high frequency TRHF antenna (2000 MHz), for detecting centimetre variations, along a regular grid size of 0.10 m (13 longitudinal profile (L) - 22 transverse profiles (T)). This grid was modelled as a "Generic model" family and, for each two-dimensional line, the raster parameter (image) of the correspondent radargram AA_L0n (or T0n) was inserted. In addition, investigation methodology, instrumentation, and interpretation of results is introduced as type parameters in form of multiline textual comments. The analysis of radargrams obtained from the AA acquisition identifies parallel lines at the surface, corresponding to the layer of a double-wythe masonry, approximately 0,35 m thick, and hyperboles that detect local discontinuities, cavities, extraneous elements, for example attributable to mortar joints, material heterogeneity or congenital limestone cracking (Figure 4.6-1). The GPR survey on vault was carried out with low-frequency TRHF antenna (600 MHz), following a grid with 3 longitudinal and 3 transverse profiles (AB acquisition). The radargrams show vault extrados and intrados

with total thickness at the key 0.35-0.40 m, while hinges about 1.20 m thick and pavement finishes around 0.10 m (Figure 4.6-2).

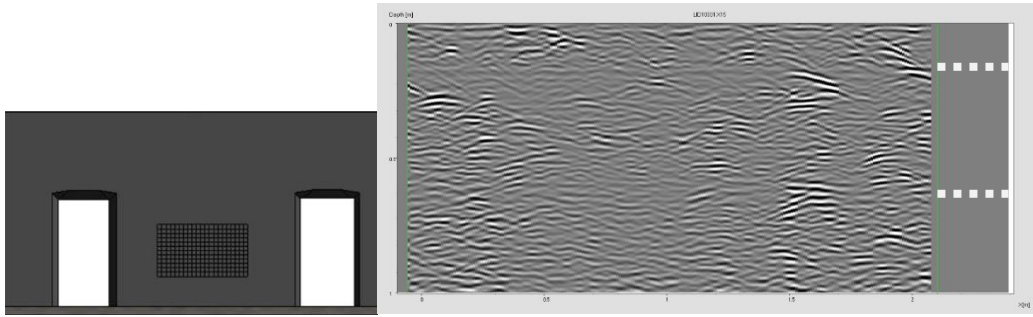

Figure 4.6-1 Acquisition profiles in a BIM object and radargram L1AA.

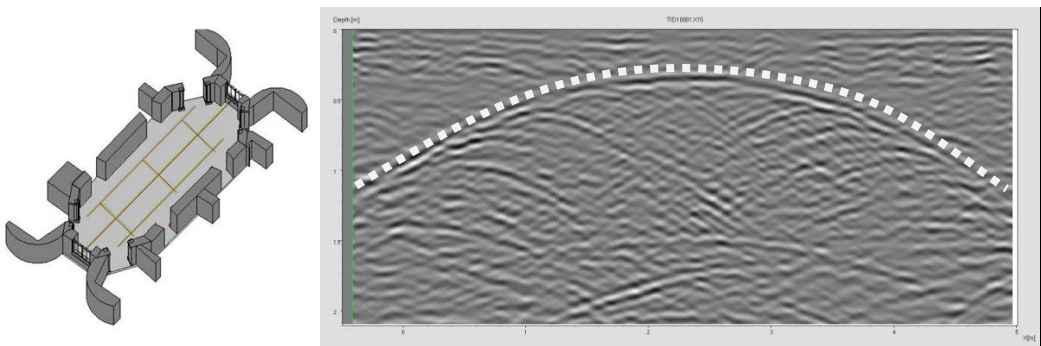

Figure 4.6-2 Acquisition profiles as BIM object and radargram L1AB about vault

Contemporarily with RGB photography, thermo-graphic investigation was conducted by a radiometric thermo-camera with a micro-bolometric sensor, mounted on a tripod in the centre of the room, in order to cover the area to be detected as wide as possible. Thermo-graphic images of walls do not contain any relevant information, while they identify vault constructive technique (Figure 4.6-3): tuff blocks of about 0.20x0.40 m, with horizontal and regular joints and bricks. In addition, the investigation has detected humidity patterns as consequence of water penetration for inadequate waterproof function of roofs. These results provide evidences of detachment of frescoes paintings and plaster when correlated with deformations of vault key detected via photogrammetric reconstruction. Thermo-graphic images have been uploaded inside customized family of the vault. The electronic documentation for collating diagnostic results (.pdf file) is

inserted as a URL attribute in the corresponding parametric object (for example: the GPR report within the object “GPR profiles”), or as textual and image attributes to be employed for generating scheduling and drawings.

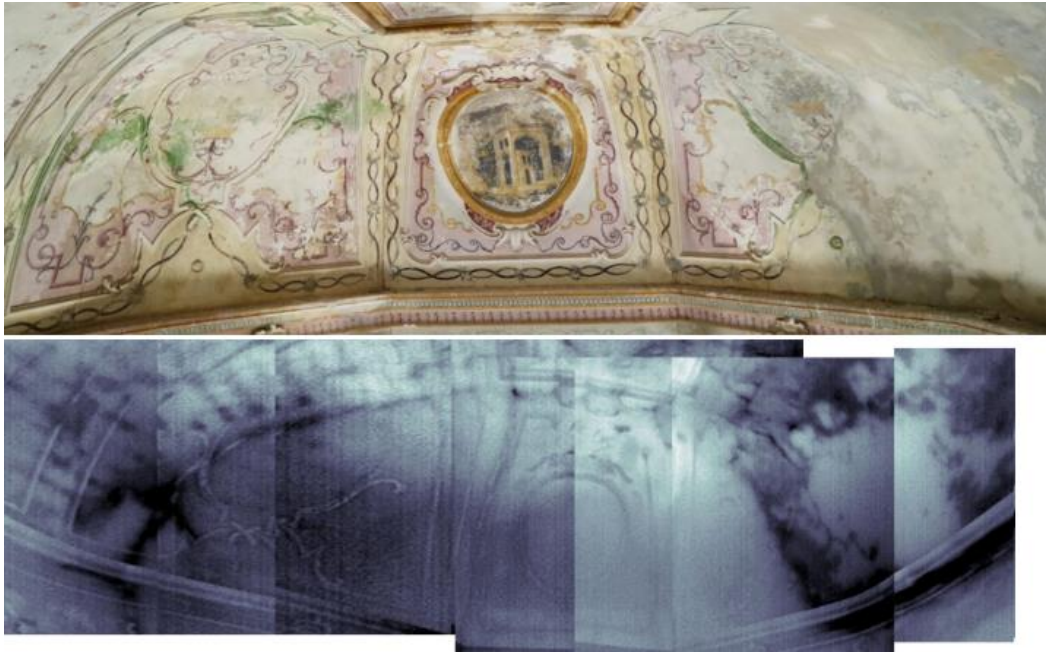

Figure 4.6-3 Photogrammetric model and merged thermal images. Source: (Di Lorenzo, 2015).

In order to streamline how searching information about diagnostic tests, a codification of related attributes has been proposed for structuring and collecting knowledge (Bruno and Fatiguso, 2018). The case study is the Bell Tower of the Cathedral of Ruvo di Puglia, Bari, South Italy (IT_S_4). The design of structural consolidation or consecutive assessment of its effective execution request the material-constructive characterization, likewise the evaluation of mechanical parameters of materials. These quantitative data enter the Finite Elements Model (FEM) for simulating the structural behaviour. Nevertheless, the complex gathering of real data generates errors in performance modelling that rise if there are losses in information delivery.

The estimation of mechanical parameters is executed after laboratory tests on a portion of each different type of masonry, and extended to the ones with similar features, identified via weakly destructive and non-destructive tests.

The information requirements have been introduced into the model in the temporal phase named 'as damaged'. The knowledge consists of identity data, diagnostic data and physical properties. The lists of attributes is shown below (Figure 4.6-4), according to the template in Section 3.5.2 (Table 3.5-1).

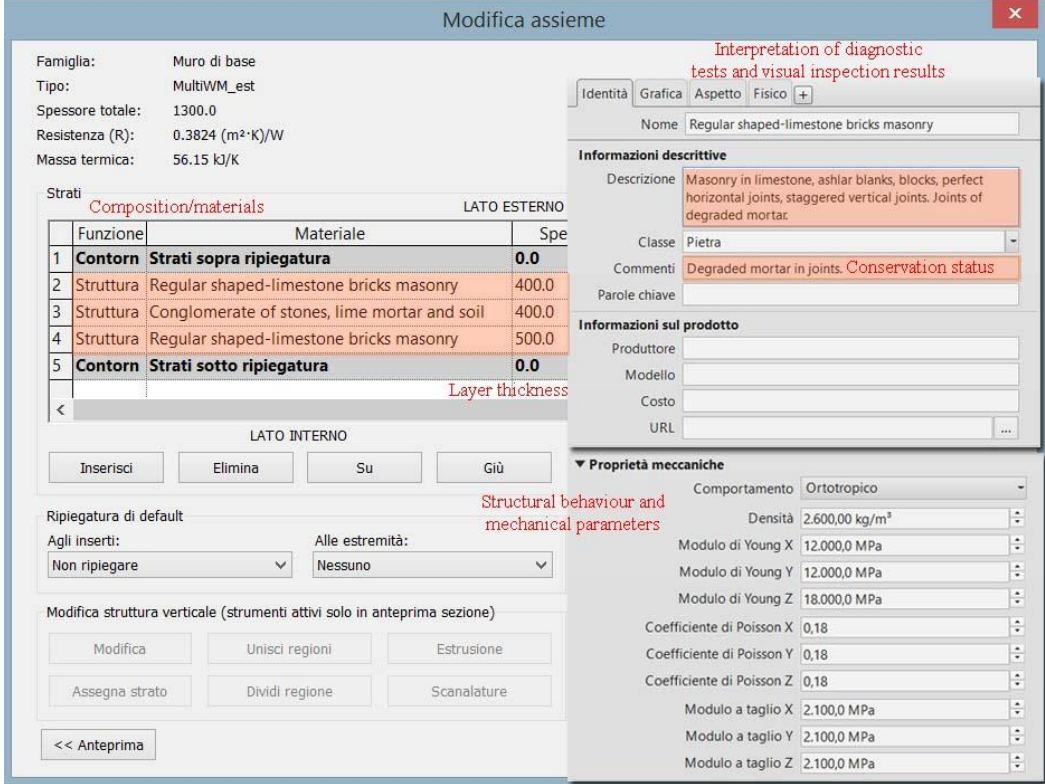

Figure 4.6-4 Insertion of quantitative data, derived from diagnostic tests, into the BIM wall. Source: author.

The BIM parameters are filtered to generate specific schedules for diagnostic reports, collecting images, data and comments in spreadsheets (Figure 4.6-5). These reports, printed in *.pdf files, can be hyperlinked.

| | |
|-----------------------|----------|
| GPR RP/2016/22/RDR/07 | |
| Owner: _____ | |
| Address: _____ | |
| 04/04/2017 22:07:47 | 03/17/17 |

Bell Tower



Deep Hole Drilling

Deep Hole Drilling Acquisition

Deep Hole Drilling Comments

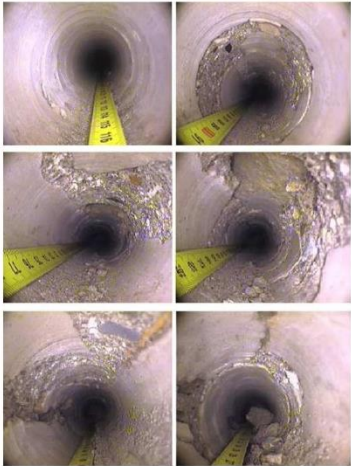

[CONFERMED] Cavities in limestone bricks for karst phenomena. Bricks thickness (Reference value): 30 cm. Consolidated masonry. Nucleus: lime mortar and stone bulk, compact and cohesive. Transversal cross bricks.

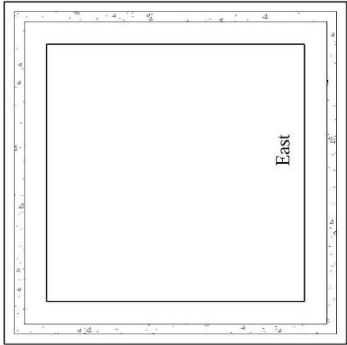

1 Level 0
1 : 100

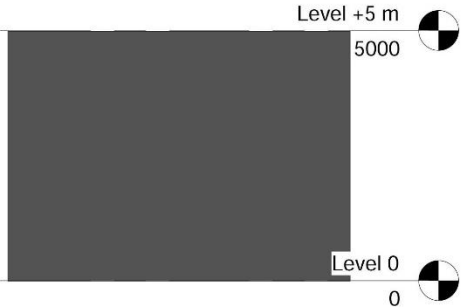

2 East_Elevation
1 : 100

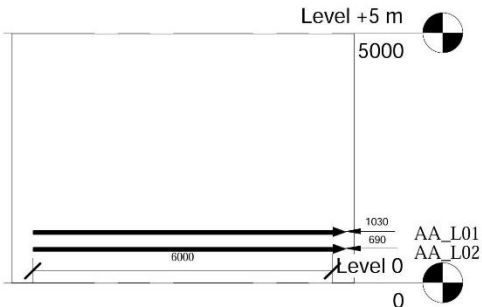

3 Localization Survey
1 : 100

| Abaco elementi di dettaglio | | |
|-----------------------------|---|---|
| Tipo | Commenti sul tipo | Descrizione |
| GPR_Profilo AA_L01 | Sistema radar IDS DAD FastWave monocanale a 16bit. Antenna IDS TR600V 2000MHZ | The radar survey was carried out on the living room wall surface portion to 0.69m from the floor and 0.96m over the edge to the left of the door. Specifically, they were acquired 13 longitudinal profiles with step 0:10 cm and 22 transverse rails with a pitch |
| GPR_Profilo AA_L02 | Sistema radar IDS DAD FastWave monocanale a 16bit. Antenna IDS TR600V 2000MHZ | The radar survey was carried out on the living room wall surface portion to 0.69m from the floor and 0.96m over the edge to the left of the door. Specifically, they were acquired 13 longitudinal profiles with step 0:10 cm and 22 transverse rails with a pitch on a total area of 0.10m 2.10m X 1.20m., |

| Comments about GPR AA Profiles | | |
|--------------------------------|---|----------|
| Tipo | Commenti | Immagine |
| GPR_Profilo AA_L01 | A hyperbola where the interface between air and brick of the deep hole drilling (about 1.30 m from the origin of the profile). Difficult identification of the horizontal line between the first layer and the core, probably caused by different thickness of bricks (20-30 cm). | |
| GPR_Profilo AA_L02 | Sequence of hyperbolas along the investigated surface corresponding to the mortar joints interposed among stone bricks. Closer hyperbole probably mark cavities in limestone bricks for karst phenomena. A hyperbola where the interface between air and brick of the deep hole drilling (about 1.30 m from the origin of the profile). A line parallel to the investigated surface can ideally be drawn by connecting the tips of the hyperbolas to downward concavity aligned to the depth of about 30 cm, this should correspond to the depth in which the ends facing the internal wall and starts at the core of the lot masonry. A parallel line to the depth of about 30 cm, probably corresponding to the end of the first layer of brick cavity. Imperceptible layer of the core because of the strong attenuation of the signal due to the presence of many air cavities within the equipment segments. The nucleus appears cohesive and consists of stones of large size, especially concentrated in the final portion of the radar profile. | |

Figure 4.6-5 Diagnostic report. Source: author.

The same template (Table 3.5-1) has been tested for the case study “Palazzo Palmieri” (IT_S_5)(Bruno et al., 2017a).

Palazzo Palmieri is a noble residence of the eighteenth century, expanded between 1769 and 1772 with the aggregation of some contiguous dwellings assuming Late-Baroque style, with influences of Neapolitan architecture. Palmieri family owned the building until 1921, when it was ceded to a charity congregation for becoming a school of arts and crafts.

In 1926 and 1928, the building went through structural reinforcement and transformation of functional use into a public school, in accordance with regulations of that period, with significant impacts on the last level, above the noble floor, where cracks and moisture infiltration had heavily compromised the wooden slabs, partially replaced, and partially recovered.

On the last level, other interventions were carried out recurrently in the years 1950-1960, such as the construction of hollow-core concrete roofs. The illustrative technical documentation also refers to interventions on the horizontal wooden slabs, in terms of increasing the resistance section, in order to adapt the structures to public and school buildings. Nevertheless, the consolidation techniques, adopted for this purpose, are not completely described in previous documentations.

The archival study has revealed that an integrated system of investigation were required on the noble floor, mostly adorned with fine decorative motifs (Figure 4.6-6); this system comprehended in-situ tests such as metric and photographic survey, mapping of cracks patterns and superficial alterations. In addition, instrumental tests have been performed, such as thermo-graphic acquisition of intrados and georadar of extrados of floors, with the aim of evaluating characteristics and conditions of components.

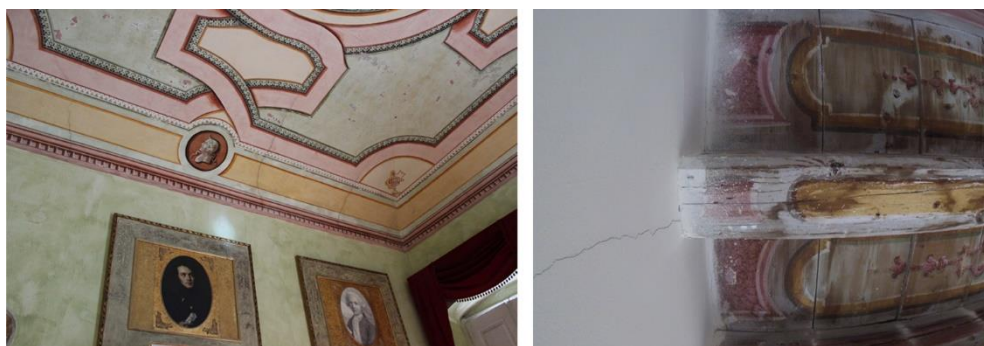

Figure 4.6-6 Vault and eighteenth-century wooden slab on the noble floor.

In particular, two aspects have emerged as particularly interesting. The first, as detected by radar scanners (IDD DAD Fastwave Control Unit and 2GHz Antenna) relates the presence of a structural system, consisting of discontinuous elements, above the wooden beams of slabs, installed with inter-axis of about 80 cm, deep 10 cm from the upper floor surface. These overlapped components are offset of 40 cm, from the original ones, and immediately below the pavements. These elements are reasonably attributable to reinforcing metal profiles, interpreting distance and amplitude of hyperbolas where electromagnetic signal is reflected (Figure 4.6-7).

The second concerns the comparability of the radar response, in correspondence of both wooden slabs and vaults. Such comparability suggests non-bearing functionalities of vaults, indeed installed to the consolidated wooden slabs, similar to those not covered. The hypothesis is proved by the results of thermography (FLIR T430sc thermocamera) taken from the vault intrados. The tests evidence the structure of wooden and wattle vaults (Figure 4.6-8), confirmed by the analysis of cracks patterns, not developed along the generative lines of a pavilion vault, but configured as widespread and random micro-cracks (Figure 4.6-8), effect of degradation of covering support.

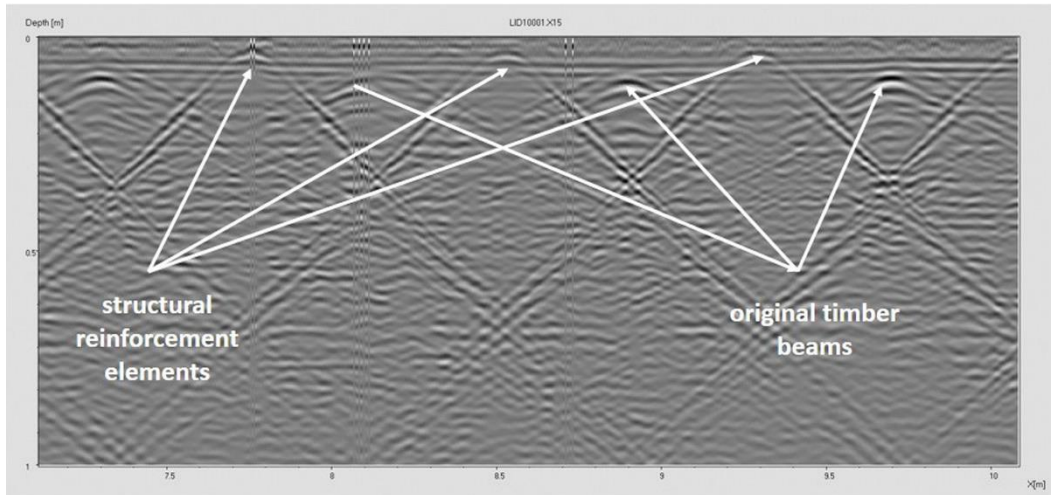

Figure 4.6-7 Response type of radar survey on wooden slabs.

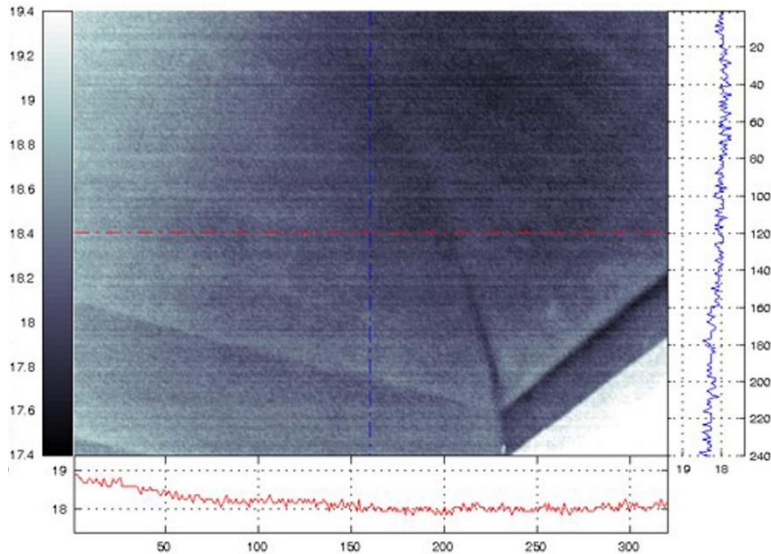

Figure 4.6-8 Thermography of a vault.

This information has been structured before being inserted as parameter-attributes related to BIM objects, defining its denomination, properties group and data type (numeric value, property and relative unit of measurement, image, URL, etc.). In the case of study, the BIM model was constructed from the available CAD drawings and it consists on the aggregation of parametric objects that model vaults (finishing and wood structure), wooden floor, moldings and decorative structures, windows and doors (Figure 4.6-9).

The attributes inherent the GPR investigations are organized within the group "Data" of instances about longitudinal profile type "GPR_ProfileX_L0n" and transversal profile "GPR_ProfileX_L0n" generated as a customized family, starting from an adaptive generic model (Figure 4.6-10).

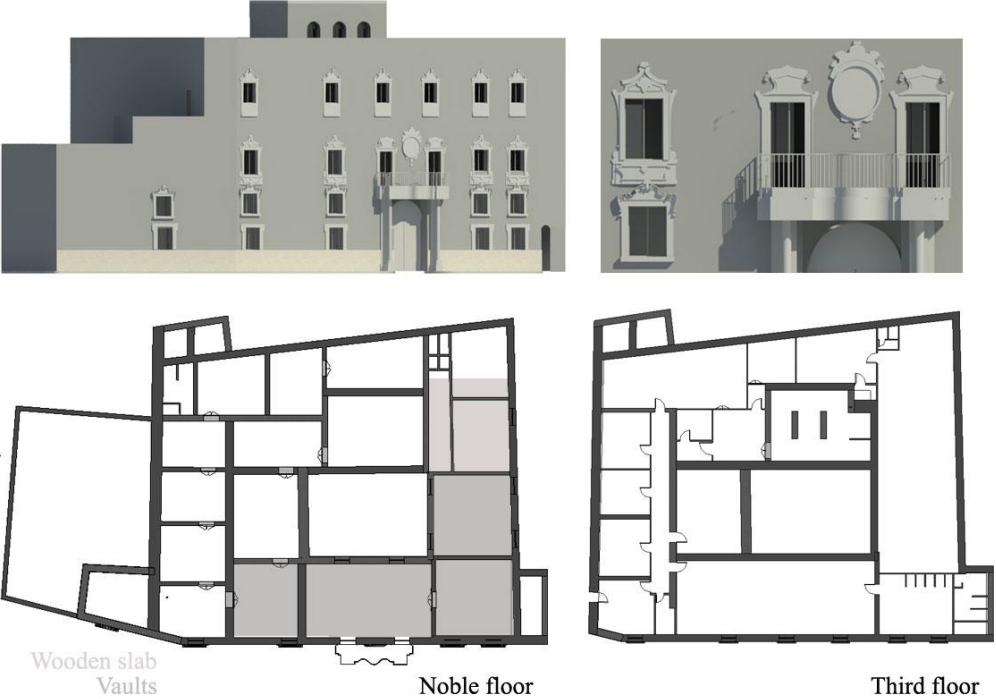

Figure 4.6-9 BIM model, front elevation, noble floor and third floor.

SHARING MODES

1_Attributes chart browser

2_Schedules

| <Comments about GPR AA Profiles> | | |
|----------------------------------|---|----------------|
| A | B | C |
| Tipo | Commenti | Immagine |
| GPR_ProfiloAA_L01 | The evidence above the beams of the wooden horizons, set at 80 cm step and about 10 cm in depth fro | AA_L01_070.png |

3_Reports in digital files and databases

| GPR Equipment and Methodology | | |
|-------------------------------|---|---|
| Tipo | GPR_Acquisition Equipment | GPR_Acquisition Methodology |
| GPR_ProfiloAA_L01 | Sistema radar IDS DAD FastWave monocanale a 16bit. Antenna IDS TR600V 2000MHz | GPR survey performed on the extrados of the third floor. Two longitudinal profiles (60 cm apart from the perimeter walls of the room) and three transversal (reciprocal distances 120 cm) were performed. |

| Comments about GPR AA Profiles | |
|--------------------------------|---|
| Tipo | Commenti |
| GPR_ProfiloAA_L01 | The evidence above the beams of the wooden horizons, set at 80 cm step and about 10 cm in depth from the footstep. In addition, a structural over-structure with discontinuous elements, offset from the original elements of 40cm and immediately below the plane of trampling. These elements, by the distance and amplitude of the reflection hyperbones, are reasonably due to reinforcing metal profiles |

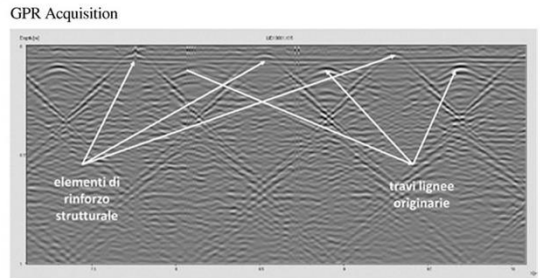

| Thermography Comments | |
|-----------------------|---|
| | The hypothesis that vaults are not structural systems, but carried by consolidated wooden slabs, is confirmed by the response of the IR thermography on the intrados of floors, from which we read the texture of the constructive solution of "wooden and wattle vaults" as well as from the analysis of mapped cracks, which do not follow the pavilion head generators, but they are configured as diffuse and random micro-cracks due to the general degradation of the plaque support. |

IR thermography

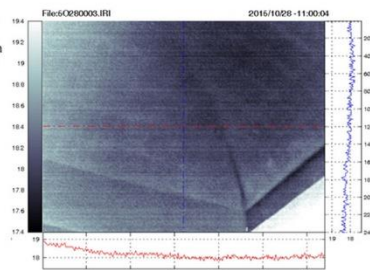

IR Acquisition

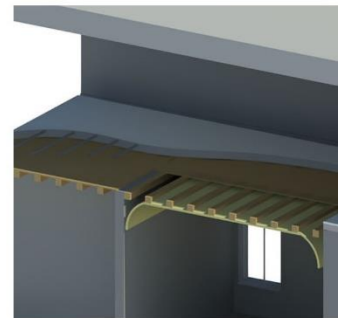

Figure 4.6-10 Management and sharing methods of attributes with BIM.

4.7 Testing the automatic diagnosis via DA-HBIMM

4.7.1 Inferential logic in the diagnosis of building decay

In order to test the automatic diagnosis via DA-HBIMM, the inference engine is proved for detecting a structural settling in an external masonry wall of the Masseria Don Cataldo (IT_S_2). This tool integrates human and machine information to deliver the possible causes and hypothesis of coherent interventions due to the implementation of a rule-based reasoning system. The application runs for detecting the settling and the causes corresponding to the visually inspected crack pattern in Figure 4.7-1 (BIM model in Figure 4.7-2).



Figure 4.7-1 Picture of crack patterns of the southern wall.

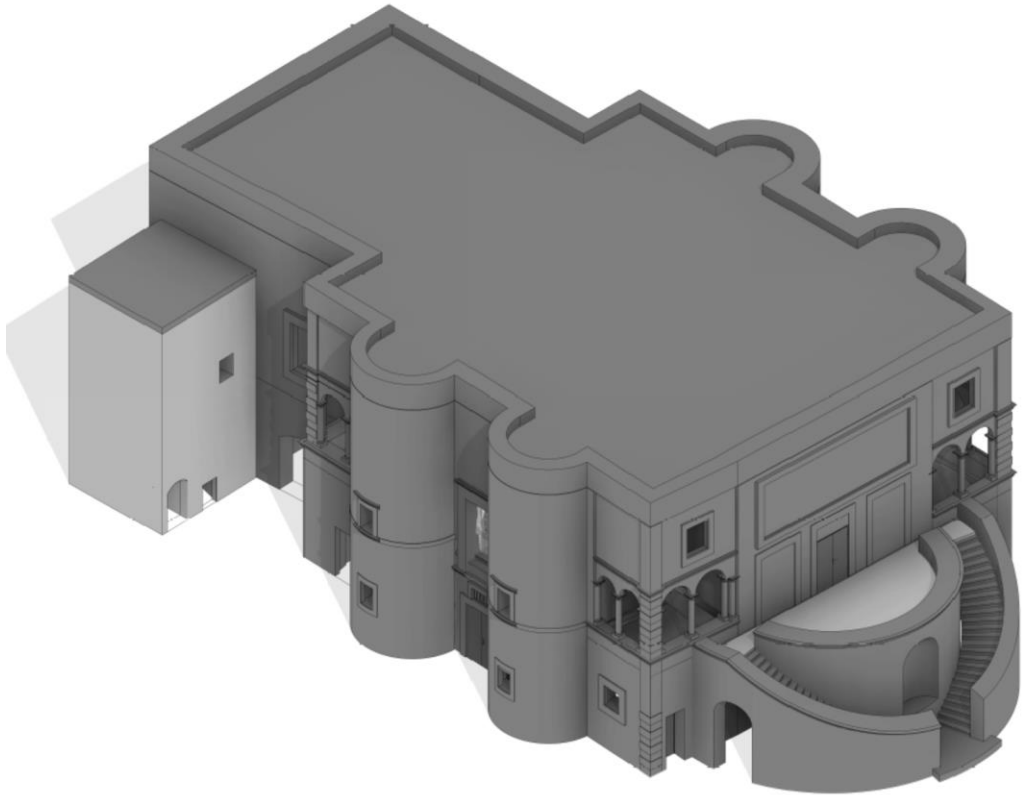

Figure 4.7-2 Masseria Don Cataldo: BIM model. Source: author.

The hypothesis is that the damage pattern could represent buckling. Generally, it could be mistaken with discontinuity of materials, absence of cross-bricks among different portions of the wall, presence of chimney, longitudinal horizontal translation and minor deformations. Surely, the settling is not caused by a chimney in the case study.

The buckling is a settling that can be caused by the combination of different causes, not necessarily contemporaneous. For this reason, the logical operator employed is the inclusive disjunction (alternation) OR - instead of the conjunction AND - that operates when a conclusion is true if and only if one or more of this evidences is true (multiply operator). In this sense, the reasoning model is a chain that infers backward and forward to connect the symptoms with the univocal connected settling and identify the actual causes on which intervene.

Firstly, the Knowledge Base (as acquired by literary review) regarding the buckling is structured and codified in the table below, distinguishing the prediagnosis (Step 1 and Step 2) as the analysis of the damage patterns, the diagnosis of the possible causes, supported by surveys for reducing the level of uncertainty (Step 3, Step 4 and Step 5), and suggestion of coherent interventions after the determination of the actual causes with a sufficiently high confidence factor (Step 6).

The Figure 4.7-3 describes the additional surveys and investigations (T2_Survey and tests 2) in order to limit the uncertainty of knowledge about the actual causes.

The preliminary hypothesis of buckling drives the selection of pre-compiled shared parameters about this settling.

In this specific case, the knowledge about the building derives from the visual inspection and historical analysis of transformations and reveal a damage pattern consisting of multiple vertical cracks on continuous wall (DP1), interesting the entire height of the ground floor of the towers and galleries (south elevation). The cracks cross the mortar joints and stone bricks, with splitting of parts of material, and there is an evident status of aging of incoherent materials (mortar). In addition, the basement of the towers was affected by overloading for subsequent construction of the upper floors, as evident from diverse material of stone blocks and masonry textures (Table 4.7-1).

| PREDIAGNOSIS | | DIAGNOSIS | | | INTERVENTIONS | | |
|---|---|--|--|----------------------------|----------------------------|---|---|
| Step 1 | Step 2 | Step 3 | Step 4 | Step 5 | AC Actual Causes | Step 6 | |
| T1_Surveys and tests 1 | DP_Damage pattern | C_Alternative causes | T2_Survey and tests 2 | AC_Actual Causes | AC_Actual Causes | I_Intervention | |
| HISTAN_Historical analysis of transformations | DP1_Multiple vertical cracks on continuous wall | C1_Structural load increase | HISTAN_Historical analysis of transformations | C1 C2 C3 | C1 C2 C3 C4 C5 | I1_Recover of structural continuity and bearing section of wall | |
| VISINS_Visual inspection | DP2_Vertical cracks with direct hyperbolic shape on isolated wall | C2_Reduction of bearing section | SONTES_Sonic tests | C4 C5 | | I1.1 Removal and replacement of damaged blocks (scuci-cuci) | |
| MORPAD_Mortar pads | DP3_Vertical cracks with hyperbolic breaking surface on pillars/columns | C3_Alteration of load distribution on bearing wall | GPR_Ground Penetrating Radar | C4 C5 | | I1.2 Cavity regeneration and filling | |
| STRGAU_Strain gauges | DP4_Splitting of parts of stones/mortar on the corners at the bottom in pillars and walls | C4_Ageing of materials (mortar decay) | BOREHOL_Drilling borehole | C4 C5 | C1 C3 C5 | I1.3 Placement of connection stone between orthogonal walls | |
| IMAGEDET_Crack detection with image processing | DP5_Wall section partialization <i>Cfr. Lateral instability</i> | C5_Low constructive regularity and quality (presence of stone bricks and thick mortar joints with low mechanical characteristic) | VEND_Endoscopy | C4 C5 | | I2_Improvement of mechanical performance of bearing section (by injections of liquid cement or reinforced bars) | |
| MESHDET_Crack detection with mesh processing | | | LABTEST_Laboratory tests | C4 C5 | C2 | I3_Geometric increase of bearing section (I4a) with same material (I4b) with different material | |
| DEFMET_Deformometer | | | GLOSTRANL_Structural analysis - global behaviour (with current regulations) | C1 C2 C3 C4 C5 | C1 C2 C3 | I4_Treatments to replace static function of damage wall | |
| <i>Obs: survey of horizontal structures (floors and vaults)</i> | | | LOCSTRANL_Structural analysis - local behaviour (with current regulations) with current regulations) | | C3 | | I5_Reduction of working loads |
| (*) Decay pattern of buckling can be mistaken with discontinuity of materials, absence of cross-bricks between different portions of the wall, presence of chimney, longitudinal horizontal translation, small deformations | | | | | | C3 | I6_Getting equilibrium in distribution of loads |

Figure 4.7-3 Scheme about correlations: symptoms, surveys, actual causes and interventions. Source: author.

| T1 Survey and tests 1 | |
|--|--|
| HISTAN | E1_ Identification of interventions on structures and building components E2_ Identification of changes in destination of use E3_ Disasters (earthquake, explosion, fire, war attacks, etc.) |
| MORPAD | E4_ Monitoring and measurements of cracks parameters (length, width, depth, direction of propagation, extension) |
| STRGAU | |
| IMAGEDET | E5_ Monitoring and verification of speed of crack progression |
| MESHDET | E6_ Analysis of stone bricks and mortar joints to identify constructive regularity and quality |
| DEFMET | E7_ Presence of deformation (for compression and bending strains) |
| Obs: fast progression, width > 10 mm , material splitting, bending → HIGH RISK | |
| T2 Survey and tests 2 | |
| SONTES | E8_ Estimation of propagation speed of mechanical waves to identify the quality of masonry, before and after consolidation |
| GPR | E9_ Presence of internal cavities, cracks, discontinuities (E9) |
| BOREHOL | E10_ Destructive test, to be punctual to analyse the borehole and the exported coring sample and identify the component stratigraphy (E10) |
| LABTEST | E11_ Laboratory tests to estimate mechanical parameters and physical/chemical compounds (E11) |
| VEND | E12_ Identification of stratigraphy (material aspect and thickness) E9_ Presence of cavities, cracks |
| LOCSTRAN | E13_ Compression strains higher than failure compression strains in pillars, column, walls (computation with current regulations) |
| GLOSTRAN | E14_ Effects on the overall building; analysis of the alternatives of intervention (computation with current regulations) |

Table 4.7-1 Description about objectives of surveys and tests. Source: author.

In a deterministic pre-diagnosis, the confidence threshold and the certainty factor are equal to 1 for evidences, conclusions and rules, so it is possible inferring:

IF “DP1 ∨ DP2 ∨ DP3 ∨ DP4 ∨ DP5 are observed”

THEN “The settling is Buckling”

But, the pre-diagnosis and the diagnosis are affected by uncertainty, thus the knowledge representation is the following:

R1: IF “DP1 (K1) ∨ DP2 (K2) ∨ DP3 (K3) ∨ DP4 (K4) ∨ DP5 (K5) are observed”

THEN “The settling is Buckling (CF1)”

Where K the confidence threshold of evidences; CF1 the certainty factor of the rule R1.

The final CF of the conclusion H is given by the formula:

$$CF'(H) = \max(K1, K2, K3, K4, K5) \cdot CF1$$

because of the evidences are related with the OR operator.

The diagnosis phase is going to be performed after the execution of the programmed surveys and tests (T2). In this step, the professionals are affected by low awareness about the correlation of the single test result with the actual causes; the awareness may improve with the integration with other data and information, thus:

R_2 : IF $E_1 \vee E_2 \vee \dots \vee E_n$

THEN "The possible causes are C_1, C_2, \dots, C_n "

R_3 : IF $C_1 (K_1) \vee C_2 (K_2) \vee C_2 (K_3) \vee C_4 (K_4) \vee C_5 (K_5)$

THEN "The settling is Buckling (CF_2)"

$CF''(H) = \max(K_1, K_2, K_3, K_4, K_5) \cdot CF_2$

The value of confidence threshold K_n and certainty factor CF_n are defined by the experts involved in the diagnostic process.

In order to find the CF of the hypothesis of buckling, the inference tree is firstly drawn associating CFs for each rule.

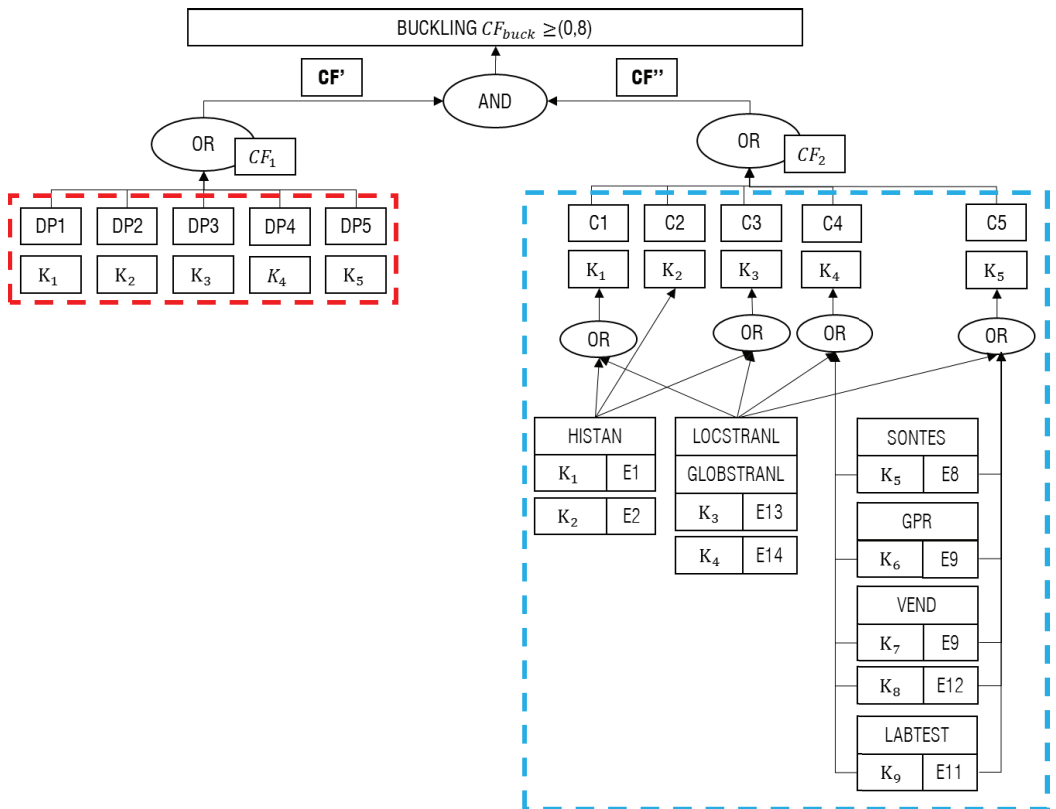

Figure 4.7-4 Inferential tree. Source: author.

The certainty factor CF_{buck} of the final hypothesis is the combination of the confidence factor CF_1 and CF_2 of the two rules R_1 and R_3 , as:

$$CF_{\text{buck}} = \begin{cases} CF' + CF'' - CF'CF'' & CF', CF'' \geq 0 \\ CF' + CF'' + CF'CF'' & CF', CF'' < 0 \\ \frac{CF' + CF''}{1 - \min\{|CF'|, |CF''|\}} & \text{otherwise} \end{cases}$$

AND The causes are $C_1 \vee C_2 \vee C_3 \vee C_4 \vee C_5$.

Established the causes, the wizard suggests the interventions (I) to eliminate the causes of settlements and improve the mechanical behaviour of the masonry.

The inferential system has been implemented in a Dynamo Studio© Autodesk script.

Before the implementation of the script, a fundamental step is the semantic enrichment of the object regarding the decay pattern (as 2D detail component) which consists of the insertion of shared parameters, defining the data type, in general using numbers and multiline text. The values correspond to the confidence threshold of each evidence involved in the rules.

The parameters about the damage pattern and the resulting comments of the surveys and test are inserted by the involved professionals (Table 4.7-2).

In this specific case, the identification of the crack patterns have been executed via visual inspection. If uncertainty occurs during the identification of the crack pattern, it is possible to use the K_n values, instead of boolean values. The engine starts after selecting the object related to the decay pattern via *Select Model Elements*, and extracts useful properties in order to detect the causes (*Element.GetParameterValueByName*). The insertion of specific parameters about survey and tests (T2) supports the diagnosis and the limitation of errors and uncertainty in the definition of the causes. Even the actual causes (AC) and the coherent interventions (I) are automatically updated by the script in Dynamo© Studio (Figure 4.7-5). The steps of the entire algorithm (Figure 4.7-6) are shown in ANNEX B in an adequate scale.

| Parameter | Data Type | Value | Case study |
|--|---------------|-------------------------|------------|
| DP1_ Multiple vertical cracks on continuous wall | NUMBER | 0/1 (NO/YES) | 1=YES |
| DP2_ Vertical cracks with direct hyperbolic shape on isolated wall | NUMBER | 0/1 (NO/YES) | 0=NO |
| DP3_ Vertical cracks with hyperbolic breaking surface on pillars/columns | NUMBER | 0/1 (NO/YES) | 0=NO |
| DP4_ Splitting of parts of stones/mortar on the corners at the bottom in pillars and walls | NUMBER | 0/1 (NO/YES) | 1=YES |
| DP5_ Transversal reduction of bearing section | NUMBER | 0/1 (NO/YES) | 0=NO |
| E1_ Interventions on structures and building components | NUMBER | 0-1 | 0.5 |
| E2_ Changes of destination of use | NUMBER | 0-1 | 0.5 |
| E3_ Disasters (earthquake, explosion, fire, war attacks, etc.) | NUMBER | 0-1 | 0 |
| E8_ Low propagation speed of mechanical waves | NUMBER | 0-1 | 0 |
| E9_ Presence of internal cavities, cracks, discontinuities | NUMBER | 0-1 | 0 |
| E11_ Low mechanical parameters | NUMBER | 0-1 | 0.2 |
| E13_ Compression strains higher than failure compression strains | NUMBER | 0-1 | 0.1 |
| C1_ Actual Cause | MULTILINETEXT | Automatically processed | |
| C2_ Actual Cause | MULTILINETEXT | Automatically processed | |
| C3_ Actual Cause | MULTILINETEXT | Automatically processed | |
| C4_ Actual Cause | MULTILINETEXT | Automatically processed | |
| C5_ Actual Cause | MULTILINETEXT | Automatically processed | |
| I1_ Intervention | MULTILINETEXT | Automatically processed | |
| I2_ Intervention | MULTILINETEXT | Automatically processed | |
| I3_ Intervention | MULTILINETEXT | Automatically processed | |
| I4_ Intervention | MULTILINETEXT | Automatically processed | |
| I5_ Intervention | MULTILINETEXT | Automatically processed | |
| I6_ Intervention | MULTILINETEXT | Automatically processed | |

Table 4.7-2 Shared parameters about symptoms, surveys, actual causes and interventions. Source: author.

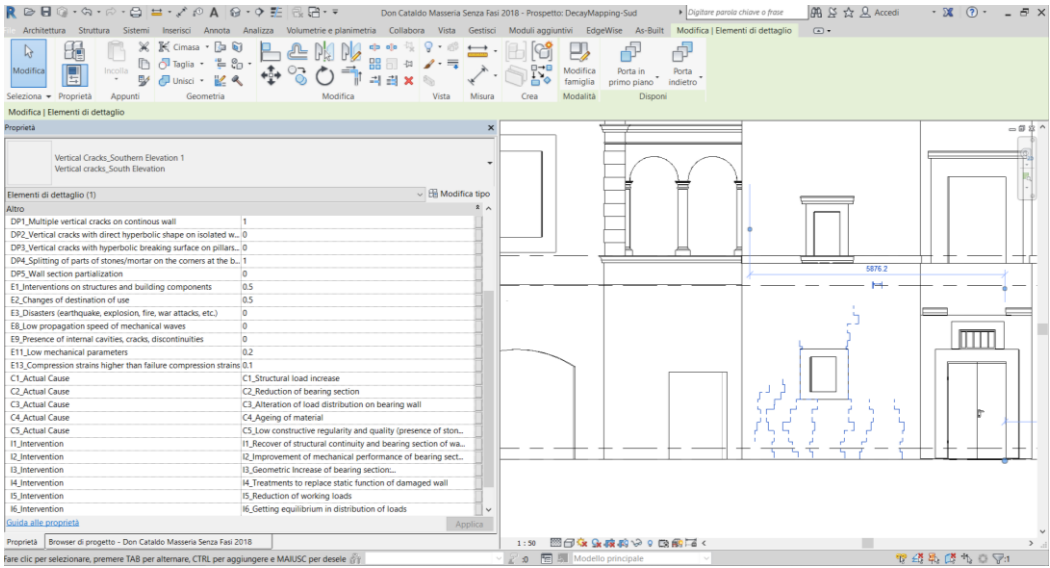

Figure 4.7-5 BIM object about crack pattern and automatic updating of parameters. Source: author.

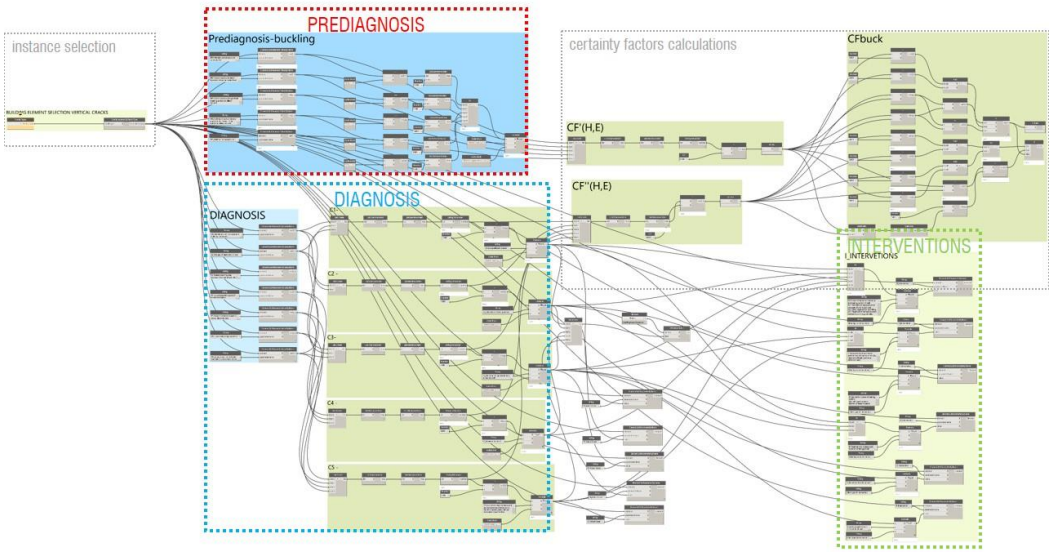

Figure 4.7-6 Algorithm for inference logics: prediagnosis, diagnosis and interventions about buckling in a masonry wall. Source: author.

4.8 Web-based documentation, analysis and sharing: the Cloud HBIM portal

In the optics of evolving from a BIM Level 2 toward a BIM Level 3, the technologies and methodologies must move toward the feasibility to work on a “single, shared, centrally located project model” in order to promote a “fully integrated methodology with collaboration of all disciplines” (Historic England, 2017). In this sense, an innovative approach beneficial for Integrated Project Delivery and sharing of knowledge among geographically dispersed end users is the use of web-based platforms (Goulding et al., 2014). The state of the art evidences the lack of interoperable platforms in FM and refurbishment (Ilter and Ergen, 2015), even if they address the achievement of effective decision making and may be beneficial for handling information and streamline the consultation (Bruno et al., 2018)(Ilter and Ergen, 2015)(Volk et al., 2014).

In this perspective, the Cloud HBIM Portal has been developed during a two-years long project that involved some English and Egyptian universities, required by the British British Council, with which the current PhD research have found a way to fulfil one of the declared objectives (‘HBIM Portal-Smart Heritage Building performance measurement for sustainability’, 2016). Indeed, it is a web-based HBIM platform for documentation and automated diagnosis and information management. The use of the platform is easier than the running of specific plug-ins because of ensuring a real integrated approach to refurbishment and provides tool for 3D viewing and point clouds management, and the use of standard web protocol permits the development and implementation of web-based services by each actor involved, also without competences in using proprietary BIM tools, and located the world over (<http://alpha.hbim.org/>).

The user features consist of the Model Creator/Browser, the HBIM Viewer and the Data Navigator:

- Model Creator: module for uploading and setting up of new models;
- HBIM Viewer: multi-functional interface and main view;
- Data Navigator: tool for browsing, graphing, and exporting the raw data stored on the server.

The Model Creator component permits the first step for producing a new BIM model on the platform, as the uploading of a 3D model, whether BIM-based or not.

The uploaded file is converted into a standard data object by the Autodesk Forge cloud conversion service, and the platform supports several model file formats, including RVT, BIM, DXF, IFC, NWD, and more. This means that any of these formats can be used as a start point for the portal and it is a feature assuring high level of interoperability (Figure 4.8-1).

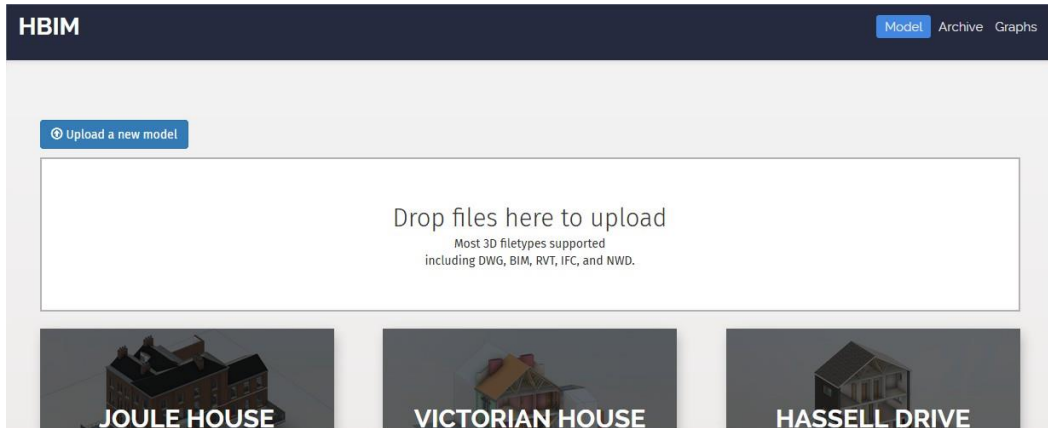

Figure 4.8-1 Enter page of the HBIM portal for uploading models and files.

The frontend of the portal is a web application for viewing 3D BIM models and contextual information; the interface presents two interconnected parts: the model viewer and the reports viewer, with a collapsible side menu for navigation. The reports viewer displays physical measurements, visual surveys, historic information, and analysis results (i.e. graphs, numerical figures, decisions) (Figure 4.8-2).



Figure 4.8-2 The reports viewer displays physical measurements, visual surveys, historic information, and analysis results.

The model viewer has the basic and extended capabilities of a 3D viewer (i.e. manipulation of viewpoint, sections, exploding model, and navigation tools).

The viewer also navigates the BIM models with an object tree mode, classified by type and hierarchy, and permits the selection of elements for opening the properties panel, structured and colour-coded by category. The platform shows building-level information about the age of the building, its name, functional use when no objects are selected. By default, the property categories at this level are Historical significance, Transformation over time, Interpretation, and Preservation (Figure 4.8-3).

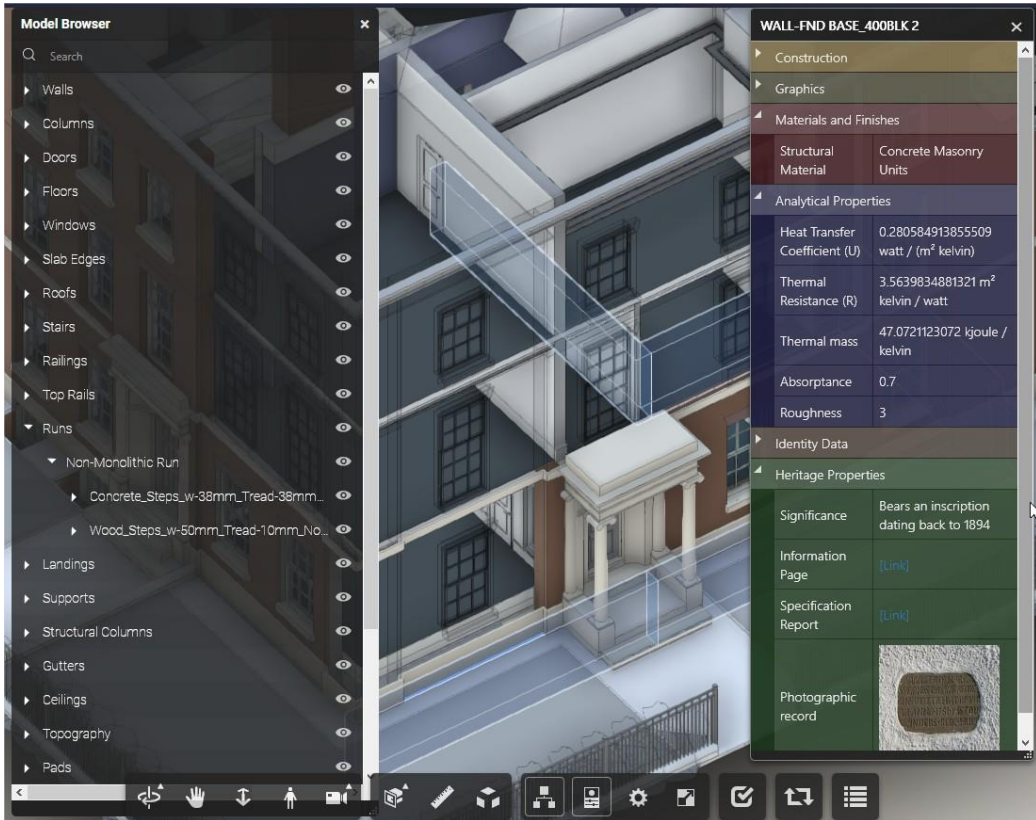

Figure 4.8-3 The property categories: Historical significance, Transformation over time, Interpretation, and Preservation.

A property editor dialog permits the addition or modification of the properties of any object; the data types of property values are text, hyperlink, and images. It manages and displays point clouds and metadata about the acquisition procedures, as shown in Figure 4.8-4:

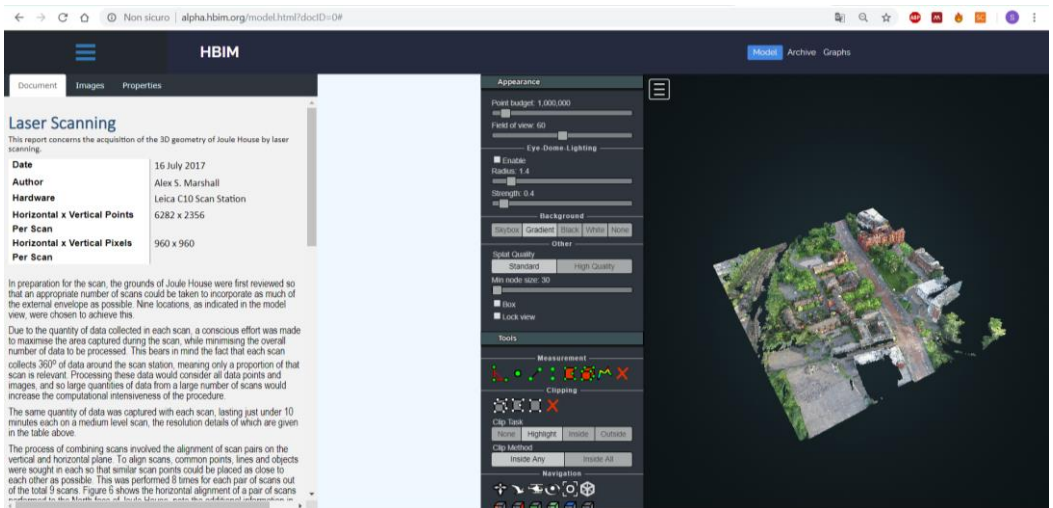

Figure 4.8-4 Display of point clouds and metadata about the acquisition procedures.

The use of mark-up permits the insertion of annotations, comments and the attachment of information in specific location, and this tool links the information in the report. In the Figure 4.8-5 and the Figure 4.8-6, the label reports the thermo-graphic acquisition executed on the related wall.

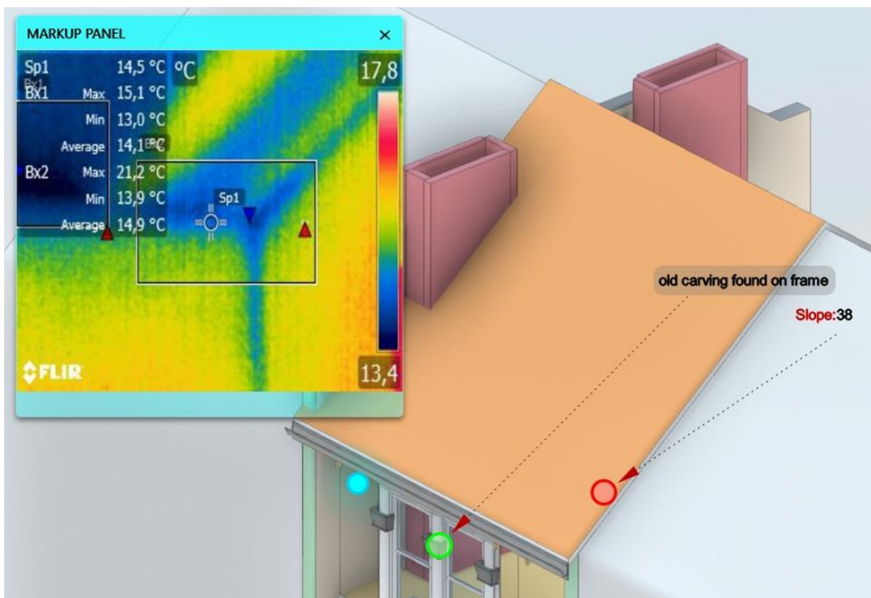

Figure 4.8-5 Use of mark-up for the insertion of annotations, comments and the attachment of information in specific location.

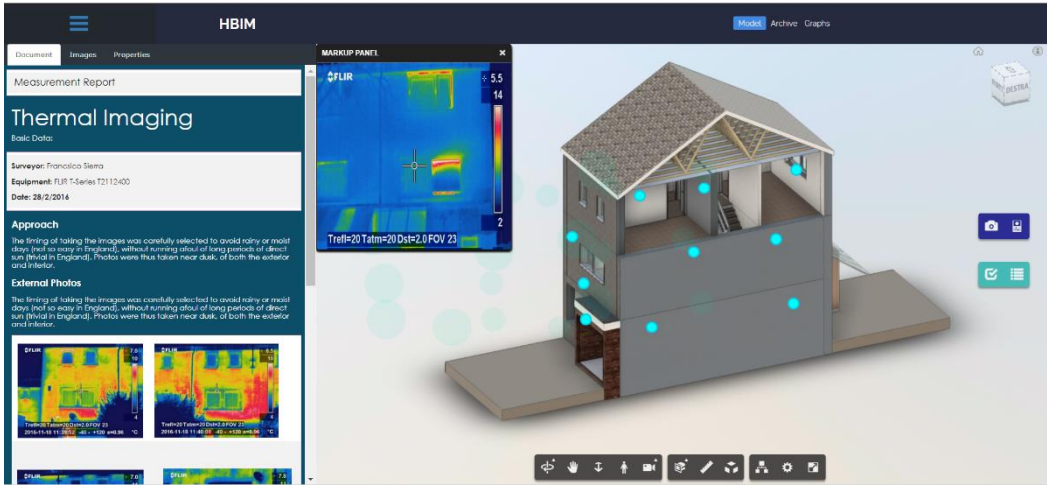

Figure 4.8-6 Thermal imaging reports. The function “state manager” is a standard data structure for grouping and recording the viewpoint, zoom status, selection, and mark-ups (Figure 4.8-7).

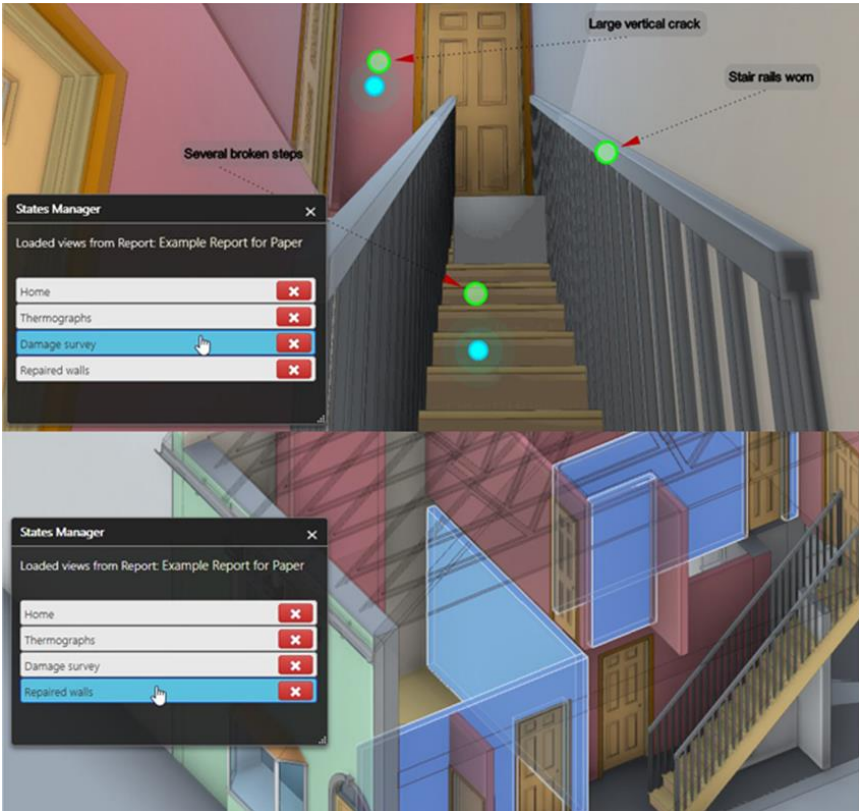

Figure 4.8-7 State manager and mark-ups of decay phenomena.

The information management is based on the automatic creation of reports, about properties, images, graphs, and viewer states. The evidences acquired by survey of damage patterns (deformations and cracks) can be marked on the model including photos and inserted in the report.

The platform displays real time monitored data in the Real-time Sensor Data View, highlighting the location of sensors using labelled mark-ups that bring up a panel with a graph of the values during the last 24 hours, and a link to the data navigator for more options.

The data navigator is displayed outside the main viewer window. It contains various options for browsing, graphing, and exporting data from all installed sensors, weather stations, and other data sources (Figure 4.8-8).

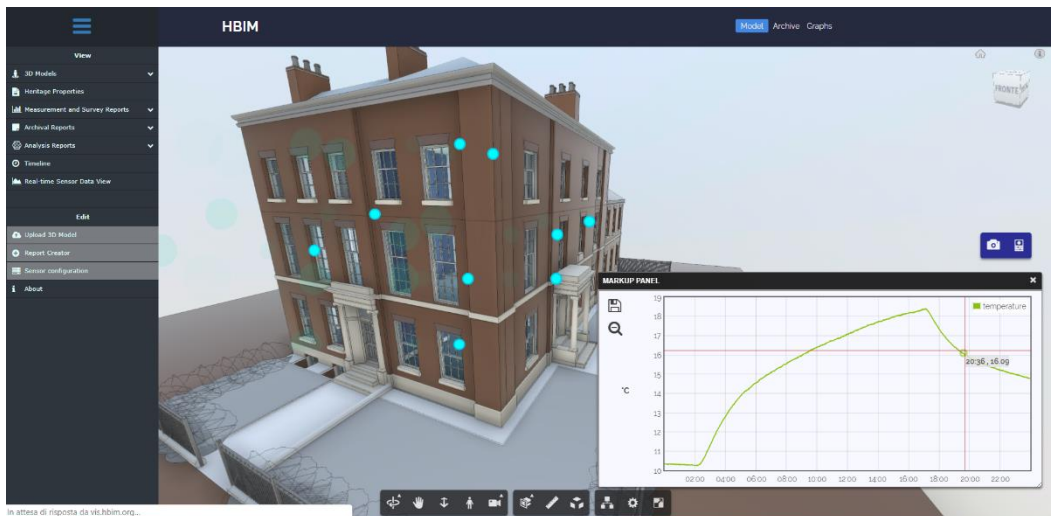

Figure 4.8-8 Real-time monitoring of environmental parameters.

The web-application manages analysis modules as set of external executable for computing model information and stored environmental data and describing and automatically reporting building performance.

5 RESULTS AND DISCUSSION

5.1 Structuration of results and discussion

After testing existing and proposed methods and tools for managing geometric surveys, modelling, diagnosis tests and condition monitoring, results and discussion are presented. This section has the same structure of the chapter 4 TESTING THE DA-HBIMM APPROACH, providing findings and analysis for each investigated step.

The [OKS] has not been analysed in detail, as it is not an explicit objective of the current PhD research, but an ongoing study will establish a defined, comprehensive and consistent EIR (Dwairi and Mahdjoubi, 2016). An overview HBIM project execution process map has been built, but the detailed BIM use process maps have not been modelled. In fact, the BPMN presented is a template that must be implemented and modified according to the objectives of the specific refurbishment project, the BIM maturity and the organization of the project team and other involved actors. In addition, contractual conditions, organizational models and ontology-based knowledge representation are not included in the scope of the research. Information Exchange (IE) and Model View Definition (MVD) are not employed and discussed, with the aim of focusing on information requirements, knowledge representation and methods of sharing data, information and knowledge useful for future advances of the IFC standards for the heritage buildings domain.

5.2 Results in reverse engineering: data acquisition and parametric modelling

The data capture for geometric survey via photogrammetric surveys is widely used in the field of architecture, design, manufacturing, demonstrating to be efficient and accurate. The accuracy of the final result depends on the sensor size and the Ground Sample Distance (GSD)¹¹, which depends on the distance from the object (the closer the camera to the object the higher accuracy and resolution of the point cloud and orthomosaics), and the chosen pixel size and focal length.

The UAV photogrammetric survey for surveying the exteriors of the Masseria Macchia Trappeto has been performed with a focal length of 3.61 mm at altitude 44.6 m and provides a ground resolution (GSD) of 1.72 cm/pixel (resolution of 3.44 cm/pixel of the Digital Elevation Model (DEM)) (pixel size 1.56 x 1.56 μm ; point cloud processing time 1hr7min; model processing time 38min46s). The resolution of the capture is not good because small objects (size lower than 1,72 cm) are not detectable such as mortar joints; in addition the total error is about 3 m, thus insufficient for a drawing scale of 1:50 required by Cultural Heritage surveys¹² (Andrews et al., 2015). The correspondent representation scale is 1:200 (2 cm maximum GSD). Therefore, a better strategy must be executed for flights with an altitude/distance from 8 m to 20 m away from the building components, in order to achieve a resolution of orthophoto of 3 mm for a scale 1:50 (Andrews et al., 2015). Whilst, the close-range photogrammetry provides three-dimensional models with ground resolution value in acquiring indoor environments (Table 5.2-1):

¹¹ Ground Sampling Distance (GSD): ground resolution in Agisoft Photoscan is the size in the real world of that part of the subject represented by one pixel of a digital image. It is a function of focal length, camera to subject distance (or flying height) and pixel size. $GSD = (H/f) \times p$ where

H = camera to subject distance or flying height

f = focal length

p = pixel size (sensor size in one axis divided by pixel count in same axis)

¹² The recommended values of GSD for topographic survey or orthophotographs from aerial photography and typical architectural scales:

1:500 – gsd < 4cm, 1:200 – gsd < 2 cm, 1:100 – gsd < 1cm, 1:50- gsd < 3mm, 1:20 gds < 2mm
1:10 gds < 1mm (Andrews et al., 2015) (Andrews et al., 2015).

| ROOMS | GSD | REPRESENTATION SCALE |
|-------|-------------|----------------------|
| R 1 | 1,750 mm/px | 1:20 |
| R 2 | 1,050 mm/px | 1:20 |
| R 3 | 0.901 mm/px | 1:10 |
| R 4 | 0.913 mm/px | 1:10 |
| R 5 | 1.100 mm/px | 1:20 |

Table 5.2-1 Comparison between ground resolution values and architectural scale for indoor environments.

The indoor shooting campaign provides three-dimensional models of the rooms with a sufficient resolution for architectural drawings in an acceptable processing time (at most ten minutes per each room).

The shootings and data processing of the rooms in the S. Agostino Monastery generated a three-dimensional model with a ground resolution of 0.994 mm/pixel at a distance of about 4 m away from the walls. Thus, the level of detail is high for displaying masonry texture and surface alterations, available for virtual representation (Virtual Reality) and remote navigation and consultation, even when in-situ inspections are not possible due to risks or distance among offices and sites (Figure 5.2-1).

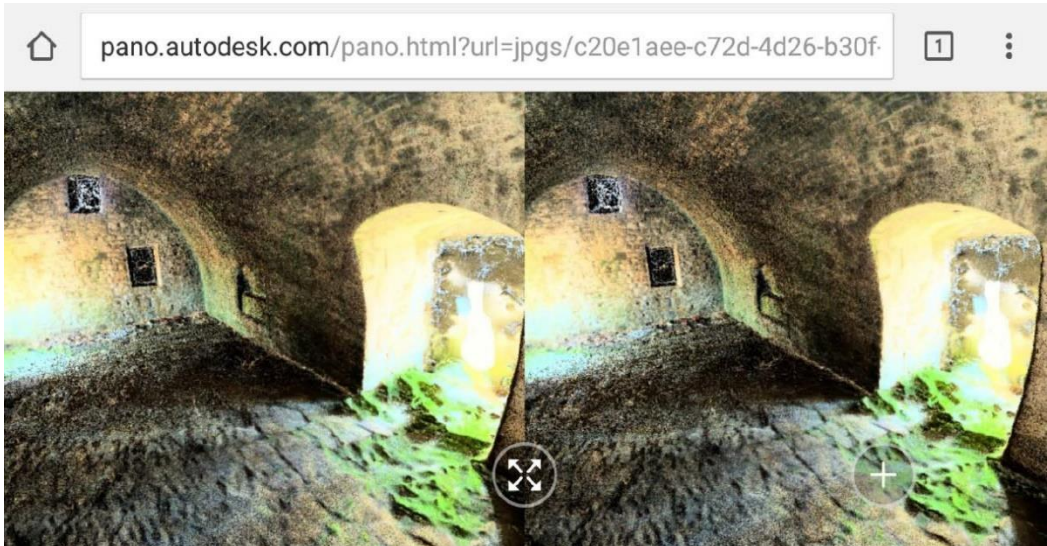

Figure 5.2-1 Masseria Macchia Trappeto: URL for Virtual Reality in Autodesk 360. Source: (Modugno et al., 2016).

Resuming, the resolution of 3D models affects the quality of ortho-mosaics and the detection of objects with limited dimensions, and it is higher when distance away from the object and the pixel size are smaller, with an equal focal length.

However, after testing the method in the presented case studies, the photogrammetric survey resulted to be not always practicable or it has not given acceptable results because of unfavourable conditions about scarce light, the presence of scaffoldings and inaccessibility of rooms. This occurred in S. Agostino Monastery where the courtyard and most of the rooms of the two floors were inaccessible and dark because of the presence of wooden scaffoldings and the closed windows with stone bricks in order to equilibrate forces and to reinforce load-bearing masonry (Figure 5.2-2).



Figure 5.2-2 S.Agostino Monastery: scaffoldings.

In these conditions, the use of existing drawings and photographs has been required. In addition, the use of UAV is neglected or required authorization in strategic areas - Aerodrome Traffic Zone (AZT) - and historic urban centres. As a matter of fact, the complement of laser scanning can support the overcoming of these identified issues.

An aspect to be underlined is the possibility of using photogrammetry for detecting and monitoring degradation phenomena in buildings within the group of non-destructive and contactless surveys due to the application of spatial gradient filters on three-dimensional models (dense point clouds and meshes) (Torok et al., 2014)(Galantucci et al., 2018).

Therefore, the acquired data provide a set of information, permanently accessible: the meshes are numerical and polygonal geometries, the NURBS provide mathematical geometries, information about textures connected to the meshes, and camera locations. The advantages of Digital Photogrammetry stand on the reasonable equipment in economic and practical terms (a photo-camera and a tripod are the minimum requirement), and on the simplicity of procedures that not required specialized users, unless a certified drone pilot is required for UAV operations. The process for elaborating photos via Computer Vision techniques is becoming more and more automated.

The execution of the close-range geometric survey with a photo-camera is acceptable when the number of rooms is not high, or when an organized team is involved in the geometric survey. Otherwise, laser scanning represents a solution for acquiring a great amount of data for the entire building in reduced time.

The issues related to labour-intensive elaboration for ordinary notebooks and personal computer liken the photogrammetry and the laser scanning, but it depends on the initial quality of the captured data in order to obtain a high resolution deliverables without overloading the hardware.

The additional benefit is the interoperability of file formats generated by data elaboration tools with other point cloud/mesh manipulation products and BIM tools. Indeed, according to the use of information, the file is exported in several formats (*.obj used in a number of 3D modelling tools, *.fbx (proprietary format), *.dwg (exporting polygonal meshes and NURBS), *.las and *.pts for exporting data related to point clouds (the

former XYZ coordinates, RGB, intensity and classification, the latter XYZ coordinates, RGB and intensity). In the testing of the DA-HBIMM methodology, the *.pts format is mostly used as it is a common format of 3D data, limiting the use of ReCap Autodesk to convert the point clouds as *.rcp or *.rcs proprietary files.

In most of the case studies, the conversion of the point clouds/meshes in BIM objects (“point-to-BIM/Scan-to-BIM”) has been executed manually, using the geometric survey as a reference, because the available tools for automatic modelling have been found unfeasible for modelling the analysed traditional masonry buildings and the workflow does not consist of frequent handover in several software tools. The walls of the main hall of Masseria Don Cataldo have been modelled with a plug-in for automatic modelling (As-built for Revit by FARO) that works also with point clouds from photogrammetry, differently by other commercial products, and performs the quality control of geometric survey via deviation analysis.

The parametric modelling of the Masseria Macchia Trappeto has been quite easier than the parametric modelling of historic buildings such as Masseria Don Cataldo, S. Agostino Monastery and Palazzo Palmieri, as complex multi-storey artefacts that have been interested by numerous transformation over time. The walls of the buildings have been modelled with in-place solid models (Palazzo Palmieri, Masseria Don Cataldo and S. Agostino Monastery) where thickness and shapes were highly irregular, while Masseria Macchia Trappeto model presents parametric walls. The choice of modelling the walls of Masseria Don Cataldo with in-place solids is depended by the results of testing the automatic modelling via As-built for Revit.

Actually, the plug-in does not recognize automatically walls, windows and openings, but it calculates the best fitting primitives compared to the point cloud, after the manual selection of two or four points. The selection of family type is still user-defined. The automation is in the recognition of the thickness of walls, openings and windows when modelling them. In the specific, if the required object is not presented into the library, the user may create it. The test of the degree of automation in parametric modelling of the main hall of Masseria Don Cataldo was possible only for openings, walls and windows, excluding decorative elements and the vault. The deviation analysis has been

conducted evaluating the percentile of points with $\epsilon < 30$ mm, according to the USIBD specification (USIBD, 2016) and the errors and scale representation suitable for surveying historic and cultural heritage buildings (2-3 cm, 1:50) (Table 5.2-2). It is fixed the acceptable error of maximum 3 cm, considering the tolerances, and reasoning on the possible divergences caused by the construction features and decay condition.

| MSD 50 mm – number of points with $\epsilon < 30$ mm (total 38997) | | | |
|--|---------------|---------------|---------------|
| Average value | Minimum value | Maximum value | Nearest value |
| 90,02% | 92,90% | 84,10% | 87,77% |
| MSD 300 mm – number of points with $\epsilon < 30$ mm (total 54957) | | | |
| Average value | Minimum value | Maximum value | Nearest value |
| 74,12% | 77,39% | 72,57% | 73,88% |

Table 5.2-2 Calculation of percentage of points with $\epsilon < 30$ mm.

In this case study, the percentile of 95% for LOA 500 (USIBD, 2016) is not achieved, also because the deviation analysis have not counted the absence of the decorative elements, the out of plumb of walls, the areas of plaster splitting, and other superficial irregularities. This evidences the low suitability of the commercial tool for automatic modelling the specific cases, and the consequent decision of manual modelling with parametric walls if regular in the cross-sections or solid modelling (in-place models) when morphologically complex (in elevation and cross-section), trying to be focused on maintaining reasonable file size.

5.3 Developments and shortcomings of semantic enrichment methods

The structuration of the current BIM platforms provides to the end-users tools that are traditionally employed, such as 2D drawing and 3D modelling ones, integrated with other capability for experimenting with the new paradigm in the construction industry about the use of databases and information systems for filtering and analysing parameters and objects by means of automated BIM-based software and pushing over the users with the availability of personalising API, visual scripting and web servers in order

to streamline the AECO processes. Focusing on the refurbishment project, the BIM features in semantic enrichment and knowledge management demonstrated to be feasible to limit the issues related to the fragmentation of information and the several documental sources that cause the missing of some important aspects and/or the incorrect correlation of evidences to detect and diagnose the causes and contributory causes of damages, building pathologies and low performances, until the recommendation of suitable interventions.

The framework about activities and information management within the BIM loop must find a strict connection with the multi-level standards about Cultural Heritage, from International to National scale. In the specific, according to the ISCARSAH-ICOMOS charter guides, objectives of surveys and diagnosis are firstly defined by professionals after the preliminary information collection [PKC] for completing qualification of the building materials and technologies and studying the global structural behaviour, identifying the interrelation among macro-building elements dated back to different constructive periods. Therefore, this knowledge must be connected with historical analysis and surveys of the present conservation state (ISCARSAH (International Scientific Committee for Analysis and Restoration of Structures of Architectural Heritage), 2003). The EN 16096:2012 delivers guidelines for examination, documentation and registration of decay and damage survey, based on visual inspection and some measurements, about existing buildings with cultural, architectural or historical value (EN 16096:2012 European Technical Committee TC 346, 2012). Generally, the standards focus on the documentation and objectives of the conservation process but exclude the definition of detailed tests and the diagnosis for adopting coherent interventions for each degradation and alteration phenomena.

Because the use of Building Information Modelling helps in managing different data types, it effectively supports reporting the general information and description about the conservation status, aiming at the risk assessment after detecting the actual causes, contributory causes, consequences on further building components.

The graphical representation in 2D drawings (floors, elevations and sections, with semiotic tables for distinguishing damages and building pathologies with symbols, colours and filled regions) is still a practical method for thematic mapping of decay.

On the other hand, the use of 2D decay mapping limits reciprocal topological connections of building elements and reduces the potential support that BIM can give in diagnosis of causes, contributory causes and consequences on further building elements. Furthermore, the filled regions employed in BIM tools are not full parametric objects, because they cannot be implemented with added attributes for describing the conservation conditions, recording with photographs, inserting information about survey methodologies, decay extension and suggested interventions. The decision of attaching some decay-related attributes to the correspondent building components and others to the filled regions (detailed photographs and comments) is not an well-organized solution when lot of types of degradations and alterations affect the same element. This is not a good data structure because it makes problematical queries of information being sparse in different BIM objects.

The three-dimensional representation can support the diagnostic phase. In fact, the hand sketches of axonometric views traditionally serve to detect the complete crack pattern related to a settling, effectively interesting the building in three dimensions. Another case is reasoning on the deformation of a wall; it can be caused by water penetration from the roof, by spontaneous vegetation, or by lateral instability with transversal reduction of bearing section, not necessarily represented on the same plane.

Hence, a 3D decay mapping has been proposed and tested aiming at the graphical representation for the diagnosis of the actual causes of decay and damages.

The use of parametric generic models permits creating specific BIM object and managing information and data (computing dimensions and extracting parameters) to be employed in views and schedules and associated to each modelled decay phenomena:

- Degradation/alteration type;
- Affected building components;
- Picture;
- Description;

- Corrective measures;
- Extension of decay/damage;
- Cost.

In this way, the quantification of extension of decay and the estimation of costs for interventions are easily implementable (Figure 5.3-1).

| Patologie puntuali | | | | | | |
|--|---|---|---|-------|----------------------|--------|
| Name | Picture | Description | Intervention | Cost | Area | Volume |
| outline - patina - local3; outline - patina - local3 | | | | | | |
| outline - patina - local3; outline - patina - local3 |  | Biodegradation of inorganic material is attributable to different types of processes: physical-mechanical processes (disintegration, micro-cracks development, destruction of stone substrate). It can be caused by autotrophic biodetergens (bacteria, algae, lichens, mosses) or heterotrophs (fungi, eumiceti, attinomiceti, birds). | Cleaning of surfaces affected by diffuse biological attachment (lichen) consisting in mechanical removal of incrustations by light brushing, application of biocide with mechanical action by scalpels; removal of stubborn residues with application of small amounts of hydrogen peroxide -120 vol. - and/or mechanical action with micro-sandblasting; continuous suction of removed material; Possible washing with solvent. To be measured as a percentage | 52.00 | 23.83 m ² | |

Figure 5.3-1 Schedule for estimation of intervention costs.

Nevertheless, the method of managing 3D objects about decay and building pathologies also presented some issues. In presence of curved surfaces, the manual localization of annotative areas (as generic models) is difficult to obtain because it need to follow the same shape of the building component. The converted point clouds or meshes - as result of manual segmentation – into 3D objects should solve this problem, but preliminary processing of the captured data is required in order to have adequate fitting of the annotation with the building element surface.

The link of the 3D models with the 3D textured model (by laser scanning or photogrammetry) represents an effective method for supporting the diagnosis phase, as it is always available for navigation and augmented visual inspection, but connection with data and information is required to correlate the knowledge. Consequently, advances in the use of 2D digital images and 3D reconstructed models (by photogrammetry and laser scanning) must be investigated in order to provide accurate and automatic damage detection and classification.

5.4 Image processing towards artificial intelligence

The testing of automatic edge extraction for modelling cracks and decay pattern – with integrated tools in BIM platform - demonstrated some pros and cons of the procedure. The advantage is the direct connection of the master model with further data as inputs (pictures, orthoimages) and outputs (detected crack in form of points or convex lines) to be employed for modelling decay symptoms and further analysis, such as diagnosis of the trigger events and causes.

The Test 2 (Canny-Sobel) provides best detected edge, but the results depend on the selection of adequate images, segmenting the surface parallel to the camera, and High Threshold, Low Threshold and sigma (employed for Gaussian smoothing). As explained in Section 3.6.1, the higher the value of the deviation standard the lower the intensity of the noise. Using a high threshold equal to 100 means that all pixels with a value larger than 100 will be a strong edge; the low threshold of 20 means that all pixels less than it is not an edge and it is set to 0. The values in the range 20-100 would be weak edges; the edge tracking by hysteresis finds the actual edges.

Nevertheless, the algorithm developed in Dynamo, which runs non-linear spatial gradients for image processing (Section 3.6.1)(Gaussian Blur, Intensity Gradient, Gradient Angle, Non maximum Suppression, Double Thresholding, Edge Tracking by Hysteresis) is not sufficiently accurate for crack detection carried on masonry walls, above all when finished with degraded plaster and frescoes, as in the case study (Figure 5.4-1). Thus, this procedure can be applied to smooth surfaces, where cracks and lacks are easily detectable. Actually, this method can be further implemented for the accurate calculation of bidimensional parameters (crack length, amplitude, perimeter and orientation) and crack classification in case of reinforced concrete structures or road pavements, as just experimented with (Prasanna et al., 2016)(Dhule et al., 2016)(Qu et al., 2018). The image processing can be implemented adding the template matching and percolation algorithm able to detect the orientation of the cracks, useful as signal to identify the related settlement. The visual recognition may help the automatic classification of the cracks. In addition, the algorithm may numerically represent the defects, integrating crack quantification & detection (estimation of length and width) and 3-D visualization

model and neural network for predicting depth and classify the morphology of cracks. The algorithm presented some issues regarding the intensive labor of the hardware, related to the complex computation. The convex hull operator requires calibration in order to detect the real points of the edges.

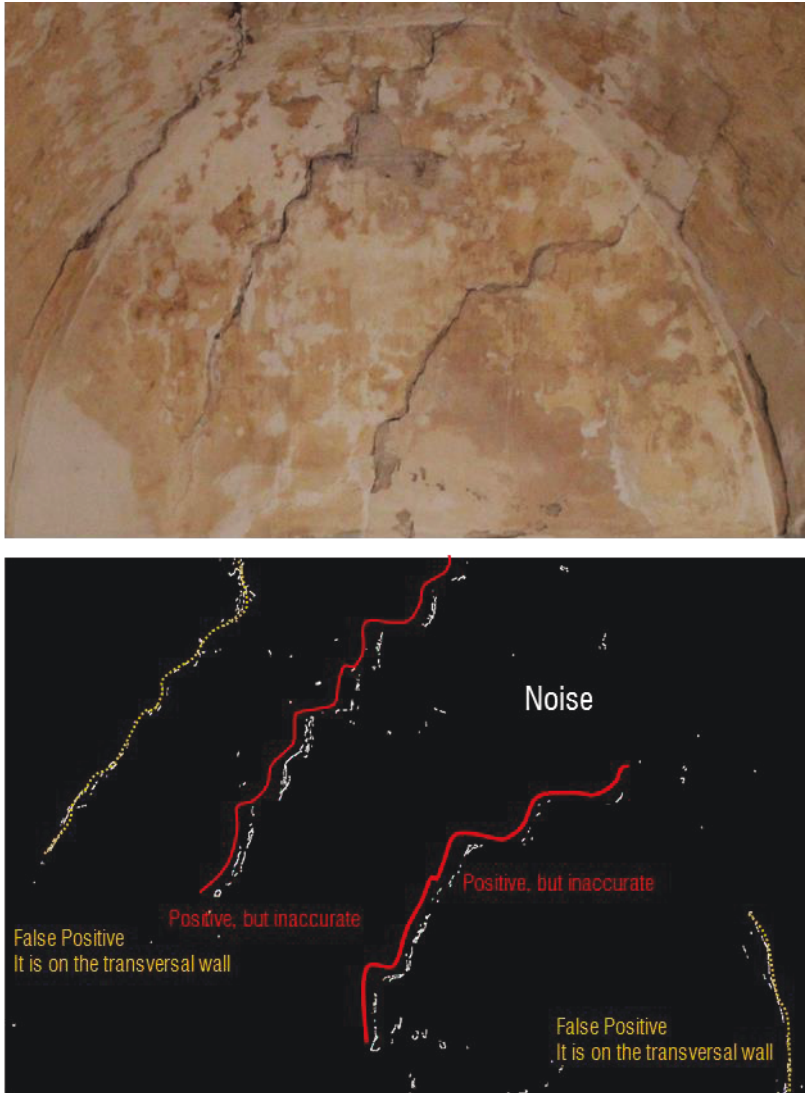

Figure 5.4-1 Comparison between original ortho-image and Canny-Sobel processed image. Source: author.

The solution to the damage detection in masonry structure is represented by 3D models analysis obtained from scanning methods (point clouds from photogrammetry and laser scanning), in order to take into account the heterogeneity of surfaces, with roughness due to stone cutting processing or actual damages. Other mathematical models may be investigated in order to assess the accuracy in detecting damages and cracks (Mohan and Poobal, 2017), both in clay and stone brick masonry and reinforced concrete structural elements.

5.5 File-based management of diagnostic surveys

The use of non-destructive test limits further deterioration of the historic building and architectural components (i.e. frescoes surfaces and decorative apparatus). The thermo-graphic technique might detect masonry degradation and humidity patterns by monitoring superficial temperature. Punctual coring generally confirms the detected stratigraphy and typology of masonry. The weakly destructive tests with single and double jacks locally estimate stress and stiffness (Crespi et al., 2015). Non-destructive tests, such as radar and seismic tests, support the extension of the quantitative attributes on building structures with similar qualitative properties. Despite the importance of the building condition assessment for refurbishment, there are no protocols, in literature, for inserting and managing diagnostic information (values of logged parameters, installation plan about instrumentation, methodology, images, diagrams, comments) in BIM approach (Bruno et al., 2018). The semantic enrichment with non-geometric data permits to achieve elevated Level of Development, almost LOD 500, 'as built model' for AIA Standard (AIA, 2013), or LOD E as 'specific model' for the UNI 11337:2017 (UNI/CT033, 2017).

The file exchange is an effective approach for project team with an intermediate BIM maturity, but the process still lacks of complete interoperability.

The first method of inclusion of diagnostic information as external reports (in .pdf) is partially implementable in BIM approach, as the information is static in the report, thus not computable in a decision-making process, but the type of linked documentation is widely readable.

Nevertheless, the insertion of data and metadata about diagnostic tests is quite efficient as diagnostic tests firstly provide multimedia or digital file (video, images, graphs), to be interpreted and inserted in the parametric object as textual comments or integer/real values with its measurement unit in correspondence of physical properties (thickness, thermal and mechanical parameters). Therefore, the second approach that utilizes computable alphanumeric attributes, with not computable image attributes, will allow the complete change in paradigm that concerns employ structured and unstructured data for automatically infer diagnosis and interventions. The use of navigable 3D photo-reconstructed model is a valid support for the documentation, monitoring and analysis of technological building systems, decay conditions and decorated elements. These information requirements are computable (physical parameters) and incomputable data (not exported attributes, images, and reports).

For this reason, the verification of interoperability among software products can support the investigation about Open Source Standard IFC or other data transfer vehicles (formats, database, server, clouds, etc.).

The export of IFC format produces missing information, such as the added parameters (alphanumeric, images and URLs).

5.6 Automatic diagnosis via DA-HBIMM

The inferential logics, run in Dynamo®, contemporarily updates the information requirements regarding the detected and represented damage pattern inferring the triggering phenomenon, the causes and suggesting the interventions. In the case study, the preliminary hypothesis “buckling” drives to the implementation of shared parameters related to this settling category. The assignment of confidence thresholds and certainty factors supports professional in the decision process, confirming or confuting the hypothesis, and it may suggest further surveys and tests to be perform to increase the final certainty factor. In the specific case study, destructive and non-destructive tests have not been performed. Thus, the certainty factor of the prediagnosis of buckling $CF'(H)$ is 0,65, but the certainty factor of the diagnosis is $CF''(H)$ is 0,40 because the confidence thresholds given to the results of surveys are 0 (no evidences) or lower than 1 (the evidences are only supported by visual inspections and fragmented archival

documentation). The final certainty factor Cf_{buck} is 0,79. In this step, the system may suggest to improve the certainty performing destructive/non-destructive tests, and local and global analysis and provide possible interventions. Specifically, the small confidence thresholds about E8_Low propagation speed of mechanical waves, E9_Presence of internal cavities, cracks, discontinuities, E11_Low mechanical parameters, E13_Compression strains higher than failure compression strains call for the execution of further investigations. This rule-based system have been developed through the use of certainty factors, because of the absence of sufficient amount of data for setting up a Bayesian model (Cimino et al., 2012). The certainty factors are assigned by involved professionals, but their selection must be guided in order to commit underestimations or overestimations. In this contribution is still missing the analysis of correlations among different decay forms and settlings, which is another factor to be taken into account for planning interventions. In addition, the use of Dynamo® permits of working per parts and not in a really comprehensive way, because of the generation of an even more complex algorithm that is difficult to manage and to run. Indeed, the software program sometimes crashes when working with large amount of data.

5.7 Web-based documentation, analysis and sharing: the Cloud HBIM portal

The management of real-time data via the web-based portal aids the automatic code checking of thresholds about measured physical properties in order to assess the indoor air quality (IAQ) in several rooms of the building (Figure 5.7-1). The IAQ is an aspect of the Indoor Environment Quality (IEQ) which affects the health, comfort and well-being of occupants in offices, work places, educational buildings, and dwellings, connected to the concept of Sick Building Syndrome (SBS) (Wang et al., 2008)(CIBSE, 2011). Whilst, the IEQ depends on indoor air quality, thermal comfort, visual comfort and acoustic comfort.

The IAQ depends on several factors, such as gases, temperature and humidity outside of the thermal comfort zone, particulates, microbial contaminants (mould, bacteria), chemical and biological pollution over standard concentrations, physical condition, and

psychosocial status (Al et al., 2016)(Wang et al., 2008). The coexistence of these aspects effects the human health causing irritation of the eyes, nose, and throat, headache, cough, wheezing, cognitive disturbances, drowsiness, depression, light sensitivity, gastrointestinal distress and other flu (Al et al., 2016)(Jafari et al., 2015). Control contaminants sources, filtering and ventilation solves issues connected to mould, dust, mite, allergens, indoor aldehydes, Volatile Organic Compounds (VOC), airborne fungi, pesticides, tobacco smoke, carbon monoxide, and carbon dioxide; additionally, cleaning operation of carpets and rugs.

The activities of occupants, such as cooking and breathing, and systems (heating, plants) generate CO₂ which might reach unpleasable levels for human well-being. Therefore, the control of SBS and other factors of discomfort requires a continuous monitoring of indoor air and environmental conditions (lighting and sound) and real-time alerts and suggestions for occupants. The dwelling in exam is not provided with mechanical ventilation, thus natural ventilation (i.e. opening of windows by occupants) should be promoted when CO₂ concentration overcomes the threshold of comfort in order to dilute contaminants and improve IAQ. The HBIM portal supports the real-time monitoring of thermal measurements, pollutants and sound/light levels in order to provide simultaneous alerts when thresholds are exceeded.

ASHRAE standard derived by Pettenkorfer's studies suggested that ventilation rate is set so that 1000 ppm CO₂ is not exceeded, as a comfort (odour criteria) (ASHRAE-ANSI, 1989). More recently ASHRAE recommended a difference between indoor and outdoor concentration not more than 700 ppm. According to European standard EN 13779, indoor air quality is considered achieved with less than 400 ppm above the outdoor level, medium quality in the range between 400-600 ppm, moderate from 600 to 1000 ppm and low above 1000 ppm. The concentration of CO₂ depends on human activities such as breathing and smoking, high occupancy and limited air change rates for the intake of fresh air. The high concentration of CO₂ provokes loss of consciousness (fainting) and limited cognitive performance. Being a web-based platform, it can be displayed from a mobile device by users in order to understand the actual building performance and receive suggestion for mitigation measures. The time resolution to

work with and the tolerance is directly modifiable on the graph. Once the configuration is submitted, the module is ran, marked by a progress indicator next to its name, until outputs are generated.

A report is automatically generated as a textual document with a static introduction about the calculation methods and the results of the analysis, and a viewer state with color-coded graphic mark-ups. The colour of the mark-up indicates risk level, and clicking it shows the graph of CO₂ levels over the analysis period. The analysis of a certain aspect of the performance of the building is an output as an automatically generated report not unlike those that were manually created, including a document, a viewer state, and properties. Each analysis module defines a set of configuration inputs, and can be run on demand or scheduled to run periodically. In Figure 5.7-1, the CO₂ sensors in the living room and the bedroom measured a normal level of carbon dioxide in the living room, and a CO₂ level higher than the threshold, thus alerting with a warning message, highlighting possible risks (expected complaints of drowsiness and poor air quality) and providing mitigation actions (open windows).

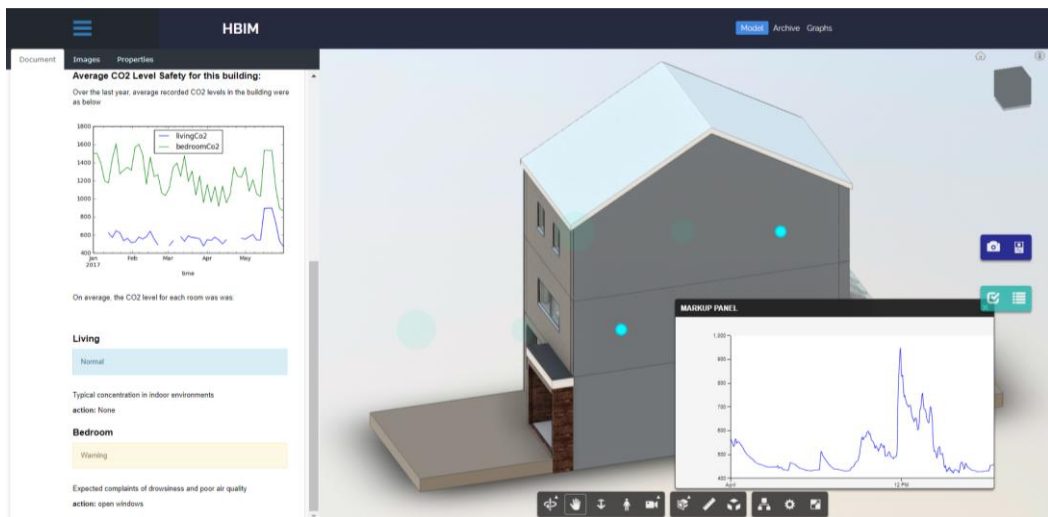

Figure 5.7-1 Real-time analysis of CO₂ levels and early-warnings measures to be adopted.

Another factor involved in the reduction of indoor air quality is related to the condensation and mould growth risks. In England, authorities and several associations are trying

to find methods and tools to solve the discrepancies between hygrothermal behaviour as simulated by software tools and real faulty one, that produces damages for condensation and mould growth even after energy retrofitting. This issue is higher in historic buildings, where some interventions are forbidden in order to preserve the historic and architectural value (such as external insulation for historic buildings with masonry solid walls). This constrain leads to the installation of internal insulation, compromising the building fabric with interstitial condensation. In historic buildings with solid walls, such as Victorian houses in Bristol, the installation of external insulation is plausible, but the condensation and mould can be a problem after interventions (May and Sanders, 2017).

The condensation risk is higher when the thermal gradients between indoor/outdoor weather conditions characterized the temperate climates, with main evidences on the windowpanes, but also affecting angles and joints of walls, and interfaces between different materials.

Water vapour can lead to condensation problems causing diffuse damp patches, without definite edges. The issues begins in areas unusually cold, such as inside exposes corners, wall to floor junctions or solid lintels, or poorly ventilated, such as kitchen, cupboards, wardrobes and behind furniture. The condensation has root causes in faults of the building fabrics and the householder 'use of the dwelling.

If the condensation is mild and intermittent, it could not represent a disturb for householder, until mould growth is visible and deteriorates decorations, produce musty smell and possible risks for the health (BRE, 1985). These phenomena contribute to reduce the durability of building elements. Consequently, the condensation control is an important factor for indoor environment quality management and for effective refurbishment.

The spores can germinate and grow over a range of temperature from 0° to 20° at relative humidity as low as 80-85%. If the relative humidity is over 70% for long periods, mould will spread. If the surface can absorb and retain water, and is a nourishment, the risk is higher and higher.

The water vapour can be express as vapour pressure (Pa) or moisture content of the air (g/kg). The air can hold the water vapour depending on the air temperature. The lower the air temperature the less water vapour is required for the saturation of the air, with constant environmental pressure, the dew point is the temperature of air saturation. When the dew point is reached, condensation will occur. In the indoor environment, it occurs when warm, moist air comes into contact with cold surface (corners, junctions, windows panes) and condenses on surfaces. The interrelation between the physical parameters involved, can be illustrated in a psychrometric chart. The assessment of condensation/mould growth risk can be obtained via the measurement of indoor temperature and humidity with wireless sensors, and external boundaries gathered with the weather station within the HBIM portal. The module about the psychrometric analysis permits to calculate the reference value of dew point at the different values of temperature and relative humidity in each room of the building. The psychrometric analysis is managed with the formulas given in the table below (Table 5.7-1):

| Symbol | Name | Data type | Formula |
|-----------------------------------|--|--------------------|---|
| θ_e [°C] | Outdoor temperature | Real-time measured | - |
| Φ_e [%] | Outdoor relative humidity | Real-time measured | - |
| θ_i °C [°C +] | Indoor temperature | Real-time measured | |
| Φ_i [%] | Indoor relative humidity | Real-time measured | - |
| $p_{sat}(\theta_i)$ (SVP) [Pa] | saturation vapour pressure | Calculated | $p_{sat} = 610,5 e^{\frac{17,269\theta}{237,3+\theta}}$ for $\theta \geq 0^\circ\text{C}$ $p_{sat} = 610,5 e^{\frac{21,875\theta}{265,5+\theta}}$ for $\theta < 0^\circ\text{C}$ the empirical formulae give the saturated vapour pressure as function of the temperature |
| p_i [Pa] | vapour pressure | Calculated | $p_i = p_{sat}(\theta_i) \times \phi_i$ |
| $p_{sat}(\theta_{si})$ [Pa] | vapour pressure at $\phi_{cr} = 80\%$ for mould growth, $\phi_{cr} = 100\%$ for condensation | Calculated | $p_{sat}(\theta_{si}) = p_i / \phi_{cr}$ |
| $\theta_{si,min}$ [°C] | Minimum surface temperature for mould growth | Calculated | $\theta = \frac{237,3 \log_e \left(\frac{p_{sat}}{610,5} \right)}{17,269 - \log_e \left(\frac{p_{sat}}{610,5} \right)}$ for $p_{sat} \geq 610,5 \text{ Pa}$ $\theta = \frac{237,3 \log_e \left(\frac{p_{sat}}{610,5} \right)}{21,875 - \log_e \left(\frac{p_{sat}}{610,5} \right)}$ for $p_{sat} < 610,5 \text{ Pa}$ |

| | | | |
|----------------|--|------------|--|
| $f_{Rsi, min}$ | Temperature factor (fabric quality) | Calculated | $f_{Rsi, min} = (\theta_{si, min} - \theta_e) / (\theta_{si, min} - \theta_e)$ |
|----------------|--|------------|--|

Table 5.7-1 Psychrometric formulae.

The superficial condensation is most commonly found on interior surfaces of building exteriors that are in excessively humid, or moist, environments. The greater the frequency and quantity of condensation, the greater the risk to indoor air quality and building structure.

The thermal bridging causes the decrease of temperature of some surfaces, even when the envelope has high temperature factors and low thermal transmittance (U-value), because of wrong installation or unfavourable geometric and thermic conditions (like-wise the wall-wall-floor corners, window lintels). This cause the increasing of the risk of condensation of water vapour or mould growth of the indoor environment, with subsequent effects of metal corrosion and rot wood. The cold point may be identified with in situ thermography, capturing the actual surface temperature to be compared with the reference value of dew point.

The risk of condensation occurs when the critical relative humidity is $RH_{cr}(\varphi_{cr}) = 100\%$ and mould growth when $\varphi_{cr} = 80\%$ in short time and 70% long periods, but it can vary with temperature variations over time, group of materials and other environmental parameters, such as low light (BRE, 1985)(Ilomets and Kalamees, 2016). In addition, a lower surface temperature in correspondence of a thermal bridge (corners, window lintels, etc.) generates higher RH on the surface, causing condensation and, then, mould growth. A method for assessing condensation and mould growth risk is proposed for “in service conditions”. After the calculation of the reference dew point/mould growth point (according to indoor/outdoor boundaries of temperature and relative humidity), it is compared with the surface minimum temperature measured with thermal images.

If the actual surface temperature is lower than the designed surface temperature and near to the dew point/mould growth point, there will be the risk of condensation or mould growth.

The results have been extracted for the Victorian House (UK_W_1) built in the period 1890-1903, featured by a cornice work and a Victorian arch. It is a single-bayed mid-terraced double storey, with traditional solid walls (solid brick wall (220 mm)). In 2016, the front and the rear façades were retrofitted with external wall insulation (100 mm EPS-expanded polystyrene).

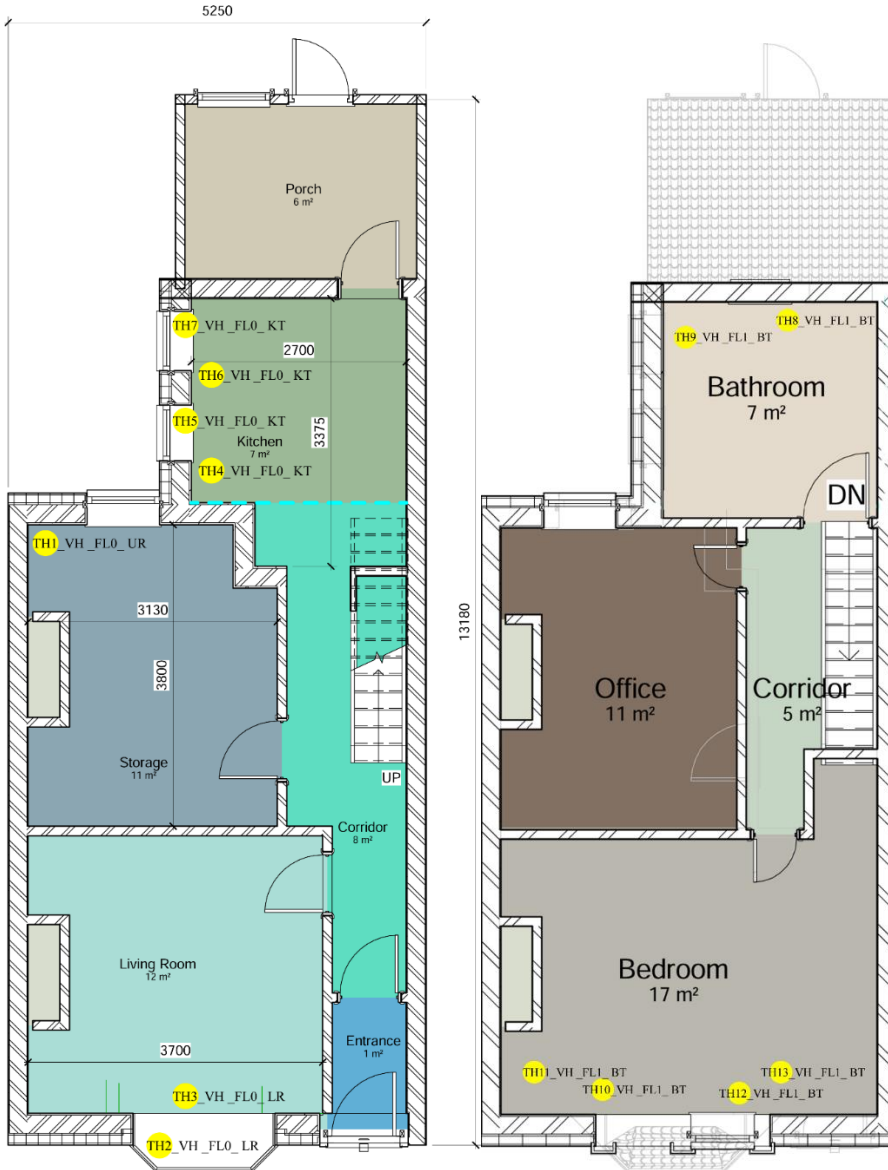

The risk of condensation is localized in corners of the bow window of living room and the corner between the roof and the external wall of the bathroom (Figure 5.7-2 and Figure 5.7-3).

Further observations regard the rising damp on the southern wall of the storage room and the draught in correspondence of the sill in plastic frame of the bow window in the living room and in the kitchen.

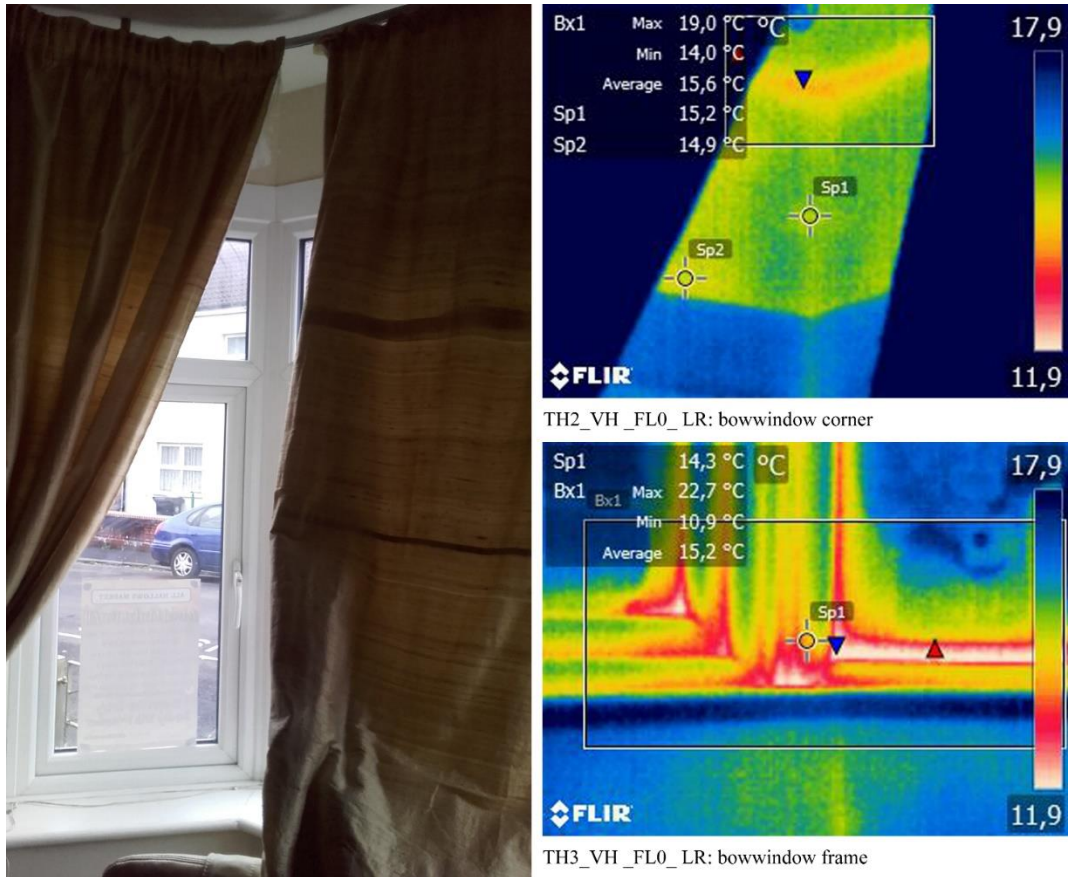

Figure 5.7-2 TH2_VH_FLO_LR and TH3_VH_FLO_LR (2016). Source: CABER, University of West England.

LIVING ROOM (internal temperature~20°, external temperature~11°) $\text{Min } \theta_{\text{si}} = 14,0 \text{ } ^\circ\text{C} < 14,23 \text{ } ^\circ\text{C}$

Possible thermal bridge/cold bridge

LIVING ROOM $\text{Min } \theta_{\text{si}} = 10,9 \text{ }^\circ\text{C} < 14,23 \text{ }^\circ\text{C}$

Draught in correspondence of the sill, plastic frame

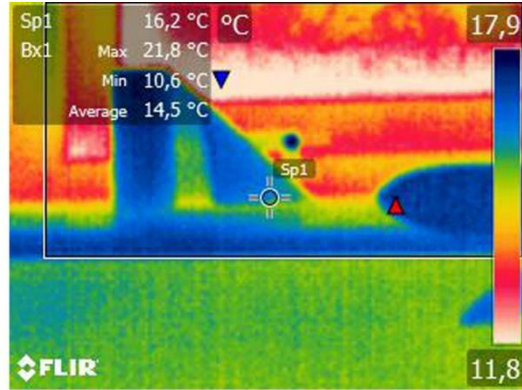

TH8_VH_FL1_BR: glazing and frame window

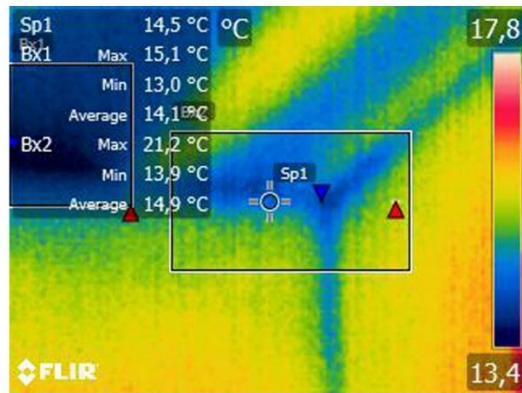

TH9_VH_FL1_BR: thermal bridge corner and roof

Figure 5.7-3 TH8_VH_FL1_BT and TH9_VH_FL1_BT (2016). Source: CABER, University of West England.

BATHROOM $\text{Min } \theta_{\text{si}} = 10,6 \text{ }^\circ\text{C} < 14,23 \text{ }^\circ\text{C}$

Draught in correspondence of the sill, plastic frame

BATHROOM $\text{Min } \theta_{\text{si}} = 13,0 \text{ }^\circ\text{C} < 14,23 \text{ }^\circ\text{C}$

Thermal bridge corner and roof

In this condition, the thermal bridge must be solved with design and execution accuracy, in order to avoid heat losses from that point:

- Better insulation of the bow window in the interface between the roof and the wall.

- Installation of window with thermal joints and micro-ventilation, and insulated sills and lintels (in four sides) with hard wooden elements and foam filled.
- Ventilation and heating control.
- Expert construction workers.

The use of the platform is easier than the running of specific plug-ins because of ensuring a real integrated approach to refurbishment and provides tool for 3D viewing and point clouds management, and the use of standard web protocol permits the development and implementation of web-based services by each actor involved, also without competences in using proprietary BIM tools, and located the world over.

The capability of the platform of managing and displaying 3D models and documents of different file format, thanks to the internet protocol and JavaScript objects is a starting point for high level of interoperability.

6 FINAL REMARKS AND FUTURE DEVELOPMENTS

The **integrated management** of incremental knowledge is a challenge felt at international level with the aim of solving errors connected to the availability of fragmented data and information in every typology of AECO project. This challenge is harder when the project team works on the refurbishment of historic and Cultural Heritage buildings aiming at **conscious preservation** and **curation**.

The refurbishment handles **complex** and **differentiated systems**, each featured by multiple specific variables reciprocally correlated. This correlation may be reconstructed by human reasoning in order to provide a reliable inference about certain goals. In addition, part of the knowledge must be discovered for planning and designing the coherent interventions, deepening all the aspects related to the existing building itself and being cautious to comprehend the **specificity** and the **authenticity** of each single historic artefact. Academics and professionals have been experimenting with approaches for digital representing the existing buildings and organising the related data; nevertheless, a connection chain seems to be flawed between the phases of **knowledge acquisition** and **refurbishment project**.

The attempts of the doctoral study have been addressed to tests the tangible effectiveness of the Building Information Modelling approach for this purpose.

As extensively demonstrated in cases where BIM has provided methodology and tools in new construction, it can ensure an integrated project and tight cooperation among actors, from the acquisition of knowledge to project closure and management. The benefits of using the Building Information Modelling are traceable with the possibility of realizing the **correlation of the variables** employing the data and information organized

within the model. However, data capture and modelling facilitates next analytical activities with the extraction of the pertinent inputs due to computational capabilities of BIM tools.

Nevertheless, a holistic approach needs to be configured introducing a variety of sources and differentiated analytical methods in order to understand the complex characteristics of the built heritage.

The doctoral research starts with a critical literature review which arises a list of gaps in knowledge about the implementation of HBIM in geometrical survey and augmented visual inspection; diagnostics and monitoring for energy retrofitting and structural reinforcement. Nevertheless, these shortcomings are not completely investigated in this research, that have precise objectives: introducing the automatic diagnosis and monitoring within the HBIM approach. Outside the research scope, solving the automatic parametric modelling from photogrammetry and laser scanning of building components with curved and complex shapes and developing a library of recurrent architectural components (Murphy et al., 2009)(Rodríguez-Moreno et al., 2016). In particular, this results ineffective for the Southern Italian masonry buildings, as historic aggregates that suffered transformation over time. The capability of BIM tools of managing URL, hyperlinks and visualizing point clouds with the 3D model allows pursuit the **reality capture** and **representation** with realistic reconstruction via Computer Vision developments (as in Masseria Don Cataldo, Masseria Macchia Trappeto and S. Agostino Monestery).

Besides, different methods have been proposed for representing and managing data (the **information requirements**) to support diagnosis and performance assessment, according to their feasibility with the particular features of each different case study. Nevertheless, the research excludes the investigation about the ontological knowledge representation, that need future studies and developments.

The aim is supporting the entire life cycle project **without losing any relevant evidence** and aiming at the automatic correlation of the investigated facts for firstly identifying the damage and building pathologies, detecting the causes and contributory causes, then assessing the risks and vulnerability. Firstly, the integration of diagnostic tests for

material/constructional characterization, performance assessment and structural monitoring has been tested as file-based management, limiting the degree of automation in computing data and interoperability. Then, the HBIM portal has been developed as method for implementing strategies of retrieving and sharing diagnostic data aiming at accurate and complete results, thanks to hyperlinks and mark-ups, geometric measurements and reports about performance assessment, as well as comments about causes and effects of pathologies, settlements and previous interventions. The proposed HBIM portal synchronises continuous measurements and monitoring with BIM models, for communication and activation of adaptive solutions according to the environmental conditions.

Some considerations are required about the data acquisition techniques beyond the usability of the BIM approach. The tests on the use of close-range geometric survey evidenced that it sometimes did not work because the execution was prevented by the presence of scaffolding and propping, the scarce or absent light, the high number of rooms, thus the implementation of laser scanning is required for more feasible and rapid data capture. In certain scenario, the hybridation of the different survey techniques, including the employment of original drawings and CAD files, solves the issues. The next step is the parametric modelling: a profound and structured research is required in order to limit the manual modelling that naturally generates errors (Dore, 2017), when it is conceivable. Developments in streamlining the modelling of irregular curved and complex shapes from point clouds and meshes may avoid simplifications, starting from progression in using NURBS (Banfi et al., 2017) and meshes (Rodríguez-Moreno et al., 2016), with the support of recognition and segmentation algorithms.

The modelling of partially demolished and transformed vaults still remains affected by geometric inaccuracy, as occurred in the analysed case studies. Therefore, the use of plug-ins for automating the modelling is inconvenient and reasonable simplifications are accepted. Nevertheless, the creation and generation of library is effective when historic buildings present recurrent architectural features (Murphy et al., 2009)(Rodríguez-Moreno et al., 2016). The integration of 3D photo-reconstruction and laser scans could

support the BIM models through a realistic representation of heterogeneous geometries, crack and pathologies patterns, and decorated curved surface (i.e. frescoes on vaults).

The recognition of pathologies and cracks within the 3D models (point clouds and meshes) could represent a key future development. Indeed, this future remark can reduce time in mapping decay phenomena in 2D views, maintain real appearance, 3D geometry and real extension of decay. This gap could be solved by integration of surface analysis algorithms (three-dimensional gradient filters) and deep learning (as convolutional neural networks for automatic recognition of speech) for damage recognition and classification within image/surface.

In addition, Virtual Reality and Augmented Reality are user-friendly and operative knowledge reuse methods useful for remote visualization of detected and analysed decay patterns and pathologies during the diagnosis and the execution phases. These methods could be additionally developed with the informative parameterisation and semantic enrichment directly executed in the textured reconstruction, in order to navigate the model, to consult geometric measurements, and to visualise degradation phenomena and automatic reports.

It has been demonstrated that the image processing is a possible extended capability of BIM tools for decay mapping and damage qualification, but future development and refinements are fundamental for its full implementation. Consequently, the monitoring of crack and damage detection can be automatically executed due to the implementation of change detection, providing alarms when risks occur. Actually, the mathematical methods may be better calibrated according to the features of the surfaces to be investigated, in order to have more accurate detection and estimation of damage parameters. The possibility of working and analytically manipulate point clouds and meshes with ad-hoc scripting can be experimented in order to upgrade the crack detection from image processing to surface processing.

Moreover, the inference engine needs to be improved and a proposed alternative would be created as an integrated plug-in or a web-based tool for automating the diagnosis. The outputs of image and surface processing can be employed as evidences (features

of the symptoms) in the reasoning chain. A well-planned use of the engine at large-scale can provide Big Data and evolve the rule-based system based on certainty factor in a Bayesian system, within the scope of reducing uncertainty. A general line of future remarks consists of developing deep learning algorithms for diagnosis of pathologies and settlements, based on acquired knowledge, taking the progresses in medicine and automotive as starting points for automatic evaluation of symptoms. This perspective of Artificial Intelligence (AI) can reduce decision making time drastically supporting professionals in identifying wrong considerations of the occurring damages and low building performances.

Thus, a machine-driven diagnosis and assessment, trained by human expertise can be achieved. This because AI is contingent on having refined data, but sustained digitization efforts should be carried out by engineers, architects and contributors in order to take advantages, maintaining the human experts at the centre of the process. In this scenario, the improvement of web-services working in the Cloud infrastructure and advanced analytics are the solution for data collection and processing. Consequently, elaboration and processing of data may be more streamlined with lower computing efforts for hardware, in order to avoid tools crashes and time delays. From the point of view of governmental guidelines, it leads at changing paradigm in the entire AECO domain toward the BIM Level 3 for ensuring the complete interoperability employing standard data and exchange protocols offered by internet services. The handover from file-based management to data-based management is gradual, but possible and it opens other potential scenario. The flexibility of tools provided by BIM platform, based on computer informatics, offers the capability of introducing innovative methods for analysing knowledge in an integrated refurbishment process, also involving infrastructures.

Even if the DA-HBIMM approach is a potential link between the geometric survey, diagnosis phase and refurbishment projects, further investigations are required, in order to eliminate additional shortcomings. Some gaps in knowledge identified by the critical analysis were not the aims of the doctoral research, thus they require the planning of future directions of investigation.

Future research may involve measured parameters, contextual information and comparison with similar cases within a Decision Support System for the evaluation of refurbishment project scenarios.

Indeed, the involved parameters could be utilised in multi-criteria and multi-agent analysis in order to calculate benchmarks and key performance indicators, or as inputs in deep learning algorithms for decision-making support of the design alternatives. In this way, the priorities and the suitable interventions can be provided after a guided process of acquisition and analysis of knowledge. According to the typology of artefact, the inferential logic can suggest interventions or conclude that it is good practice to not intervene, as occurring for conservation of archaeological site. The human expertise helps the process thanks to its consciousness of the authenticity of each historic building.

ANNEX A

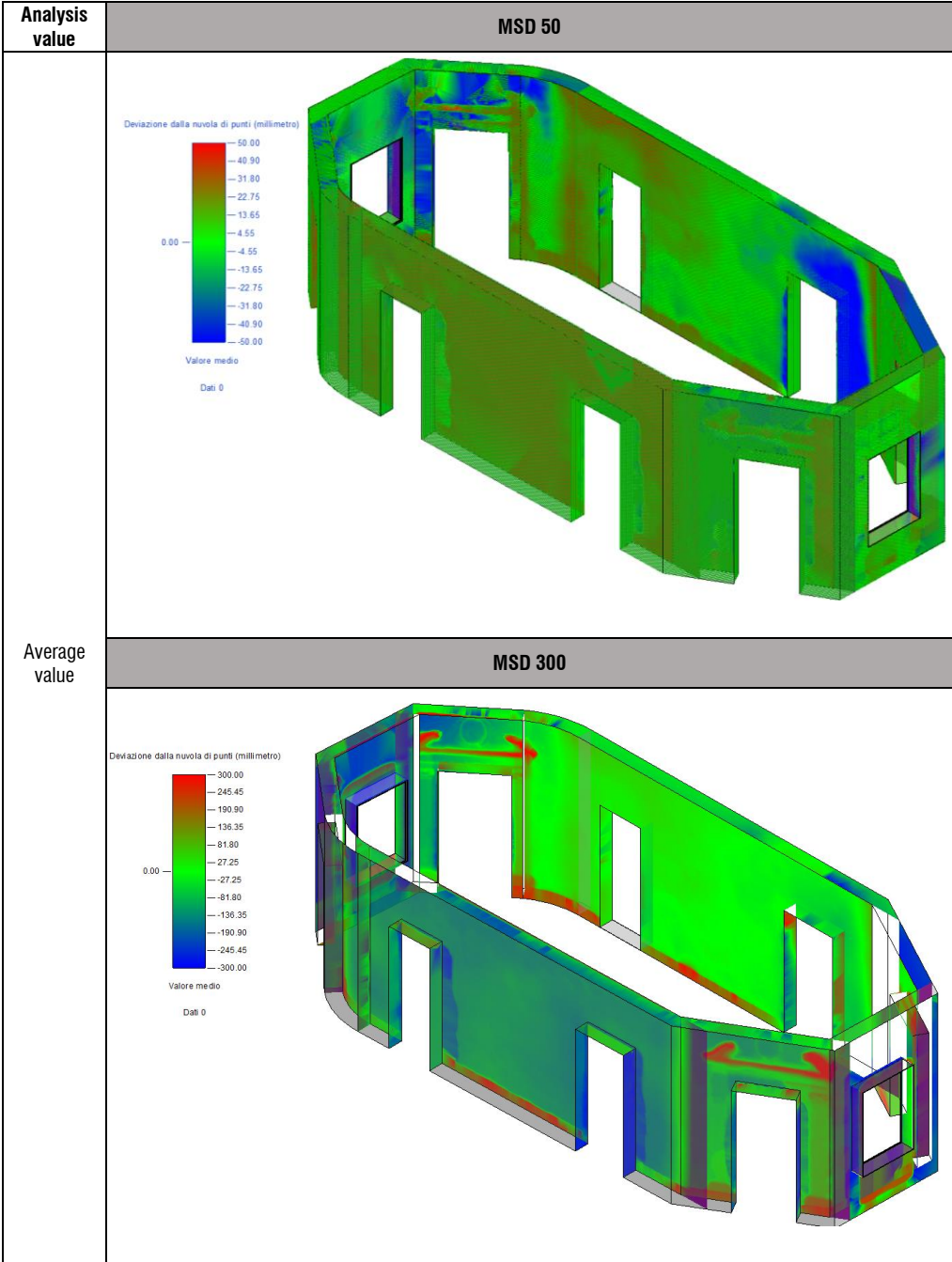

| Analysis value | MSD 50 |
|----------------|---|
| | <p>Deviazione dalla nuvola di punti (millimetro)</p> <p>— 50.00 — 40.90 — 31.80 — 22.75 — 13.65 — 4.55 0.00 — 4.55 — 13.65 — 22.75 — 31.80 — 40.90 — 50.00</p> <p>Valore minimo</p> <p>Dati 1</p> |
| Minimum value | MSD 300 |
| | <p>Deviazione dalla nuvola di punti (millimetro)</p> <p>300.00 245.45 190.90 136.35 81.80 27.25 0.00 — 27.25 — 81.80 — 136.35 — 190.90 — 245.45 — 300.00</p> <p>Valore minimo</p> <p>Dati 1</p> |

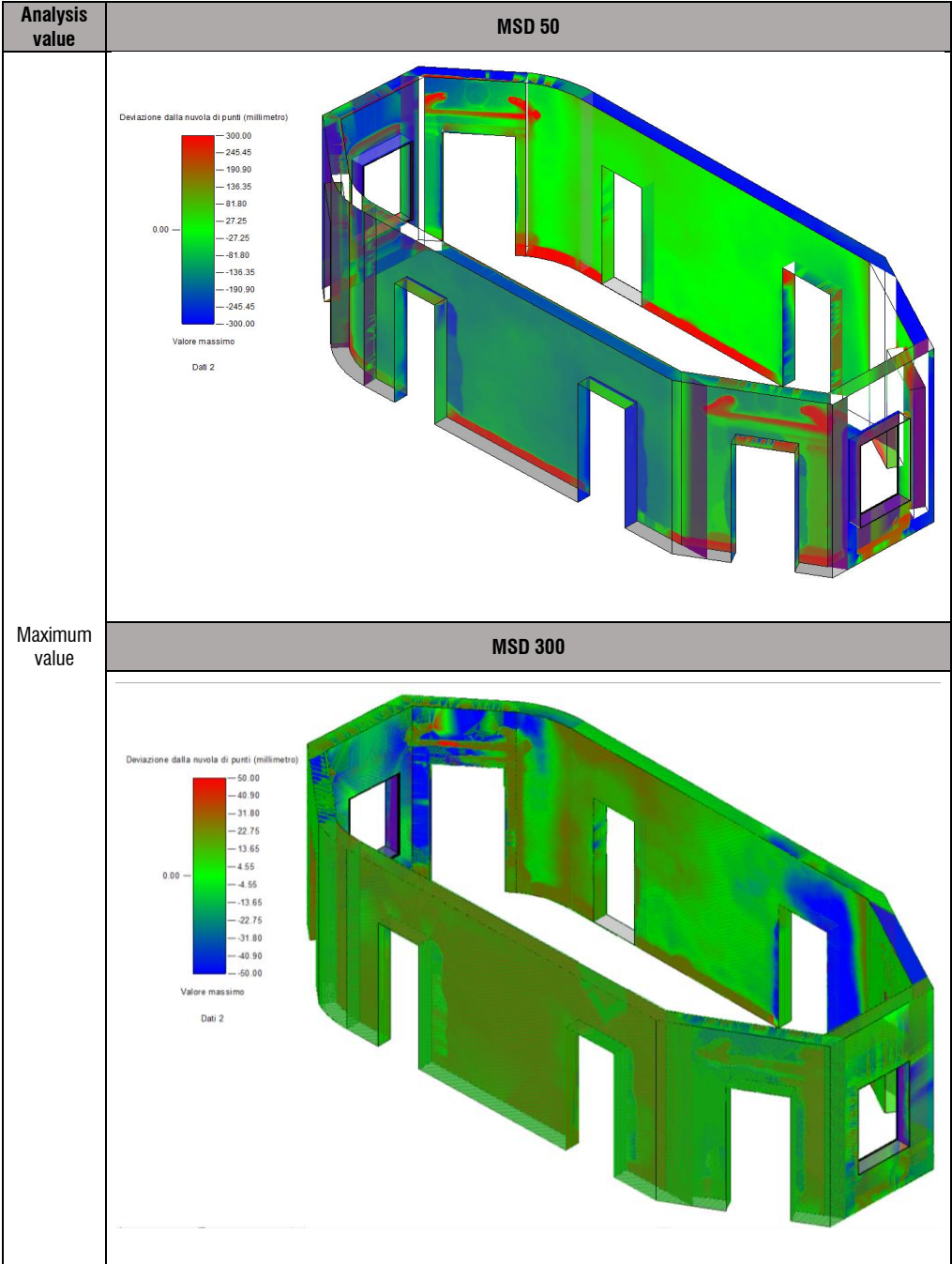

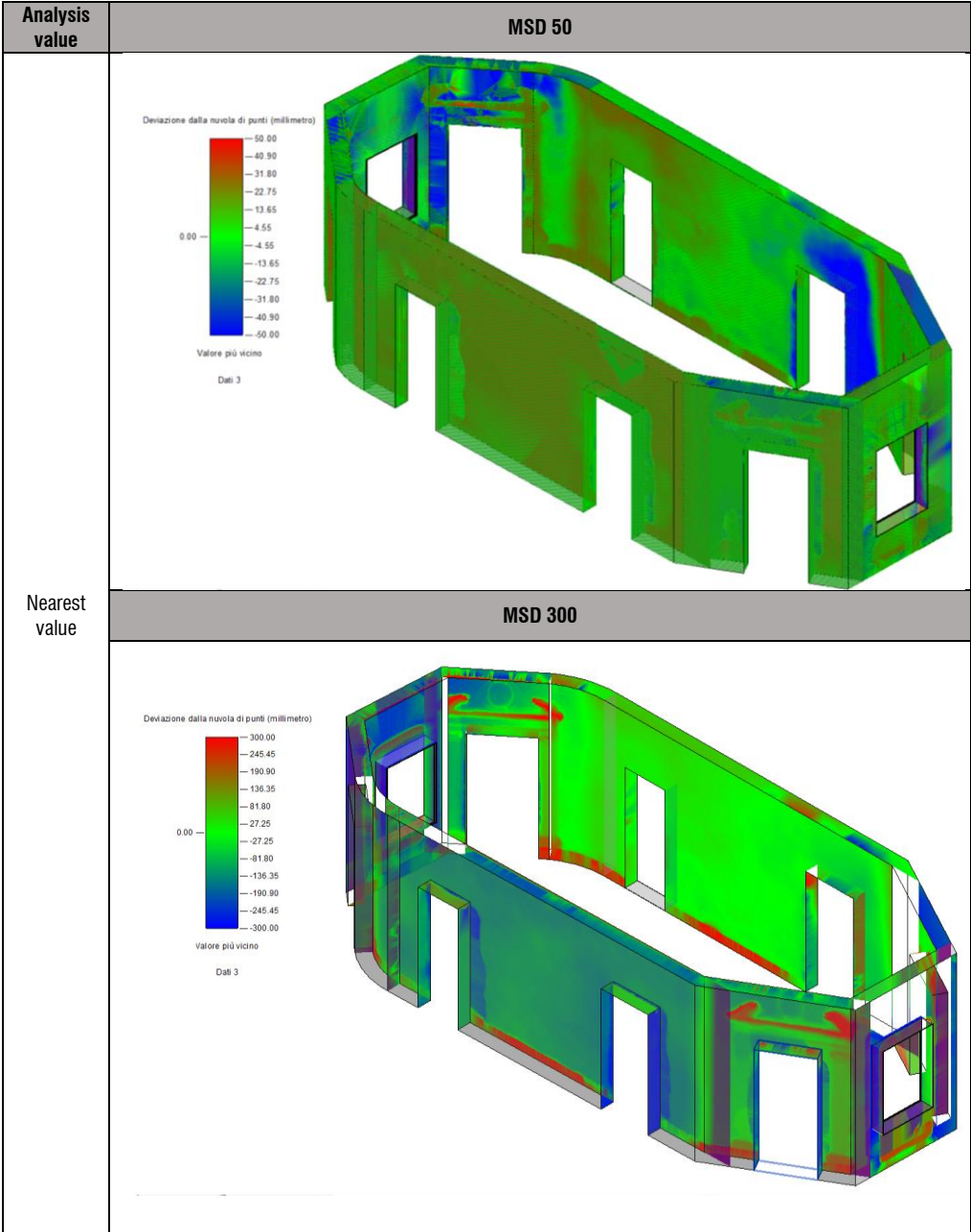

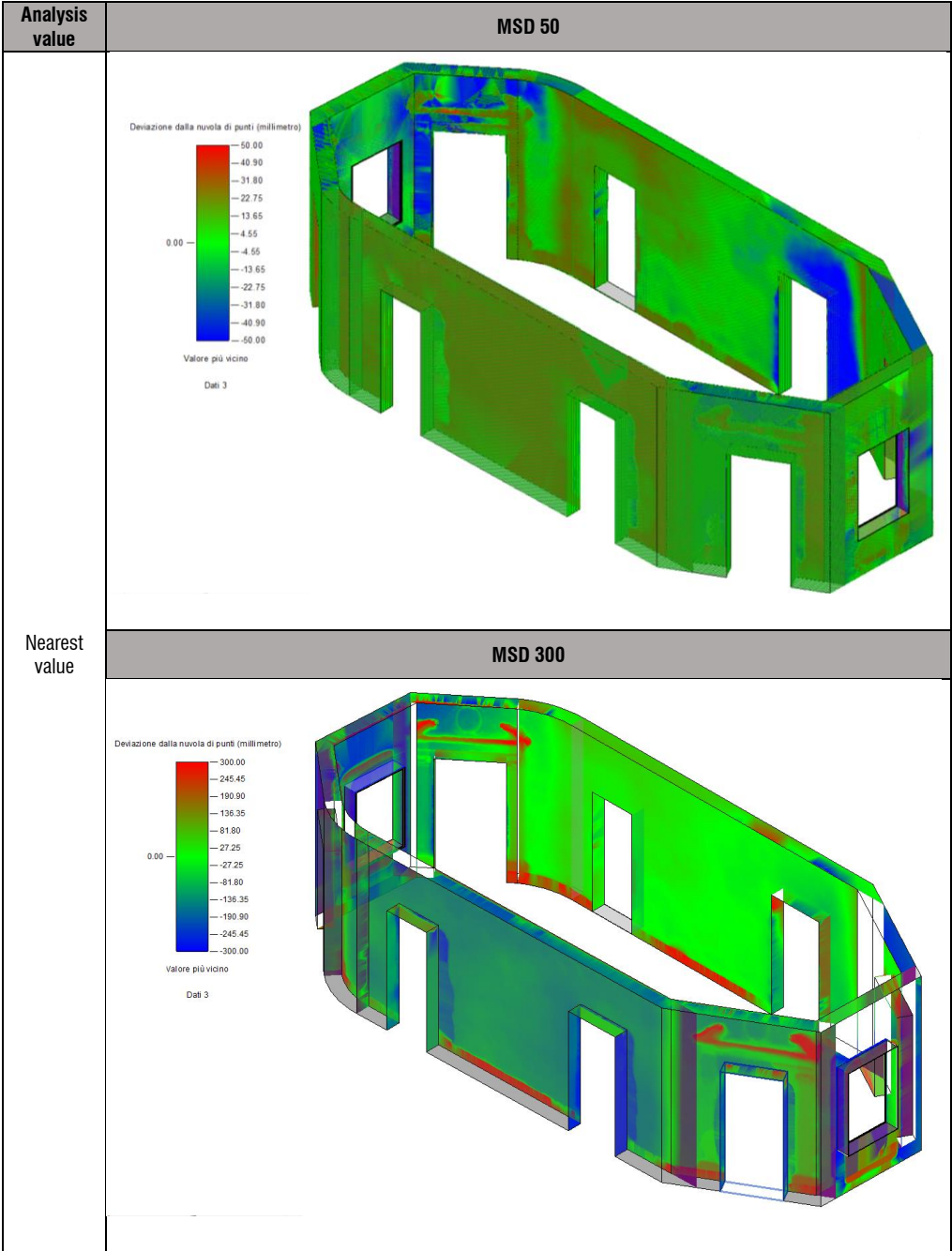

Analysis value **MSD 50**

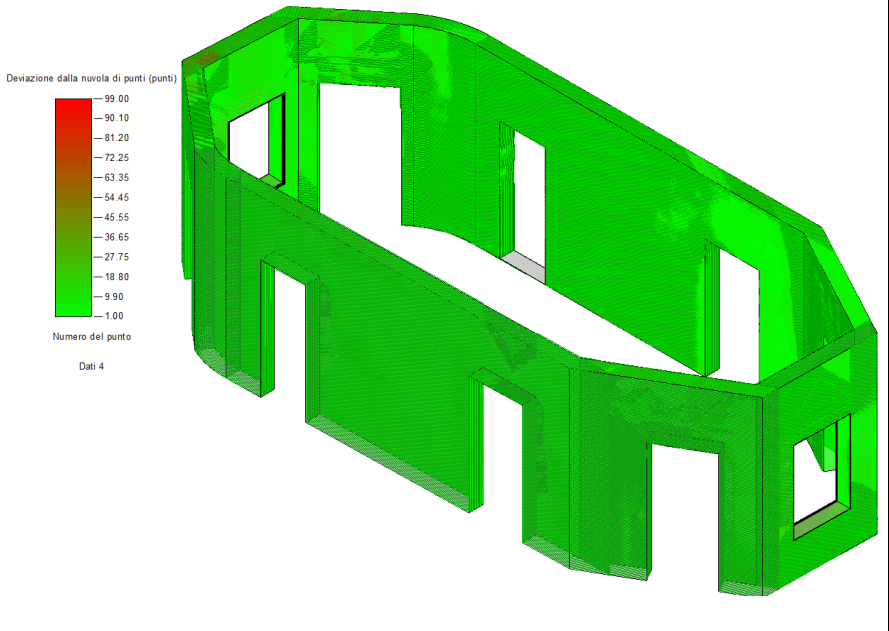

Number of points **MSD 300**

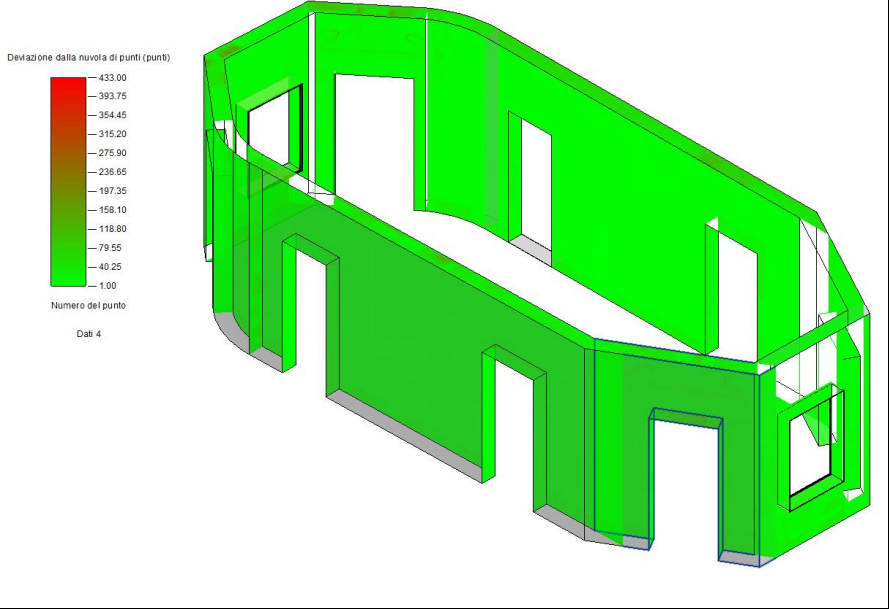

ANNEX B

ANNEX B

BUILDING ELEMENT SELECTION VERTICAL CRACKS

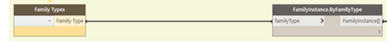

Predagnosis-buckling

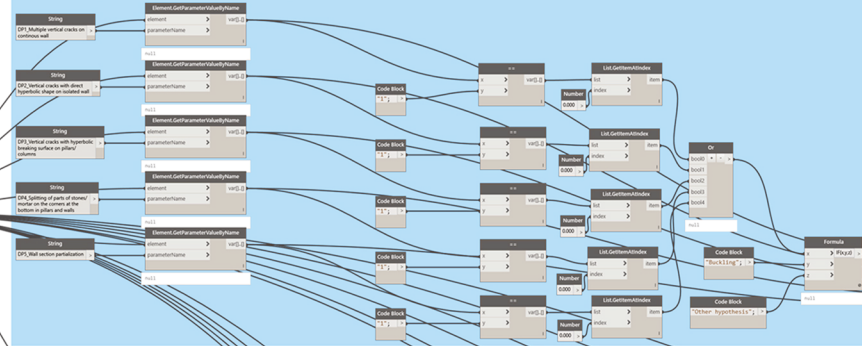

DIAGNOSIS

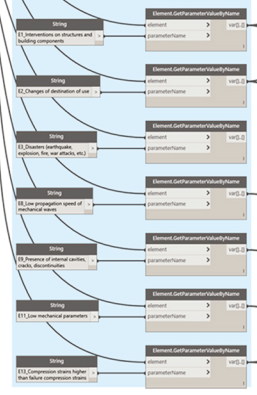

C1 -



C2 -



C3 -



C4 -

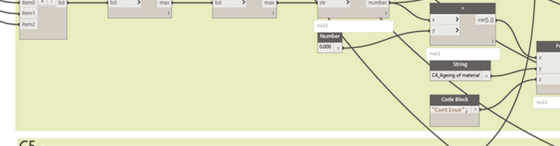

C5 -



CF'(H,E)

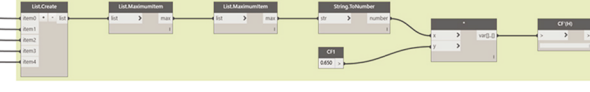

CF''(H,E)



CFbuck

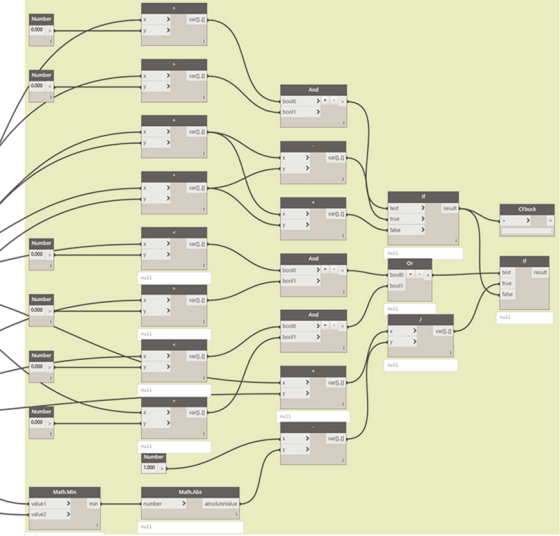

I_INTERVENTIONS

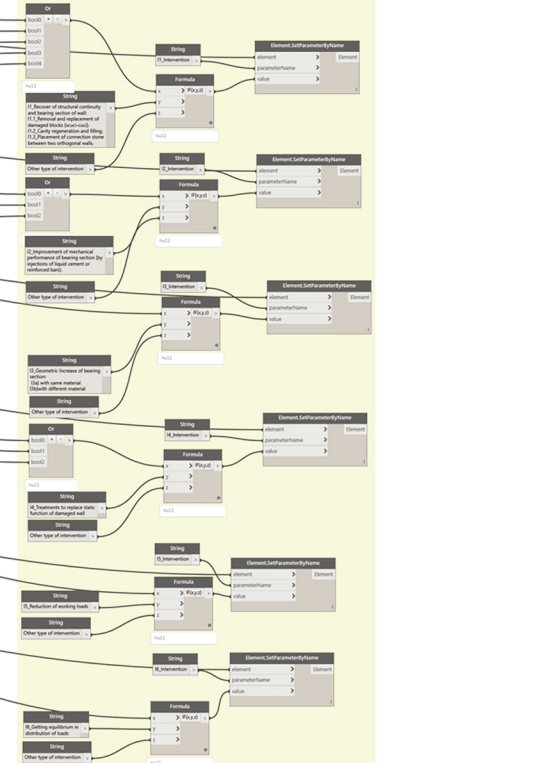

REFERENCES

- Abdelalim, A., O'Brien, W., Shi, Z., 2017. Data visualization and analysis of energy flow on a multi-zone building scale. *Automation in Construction* 84, 258–273. doi:10.1016/j.autcon.2017.09.012
- Achille, C., Fassi, F., Fregonese, L., 2012. 4 Years history: From 2D to BIM for CH - The main spire on Milan Cathedral, in: Guidi, G., Addison, A.C. (Eds.), 18th International Conference on Virtual Systems and Multimedia (VSMM): Virtual Systems in the Information Society & Applications to Heritage, 2-5 September 2012. IEEE, Milan, Italy, pp. 377–382. doi:10.1109/VSMM.2012.6365948
- Adams, S.M., Friedland, C.J., Levitan, M.L., 2010. Unmanned Aerial Vehicle Data Acquisition for Damage Assessment in hurricane events, in: 8th International Workshop of Remote Sensing Disaster Management 30 Sept-1 Oct. Tokyo, Japan.
- Adeli, H., 1988. Expert systems in construction and structural engineering.
- AForge [WWW Document], 2013. URL <http://www.aforgenet.com/framework/>
- AIA, 2013. Document G202 – 2013 «Project BIM Protocol Form».
- Al, Y., Arif, M., Katafygiotou, M., Mazroei, A., Kaushik, A., Elsarrag, E., 2016. Impact of indoor environmental quality on occupant well-being and comfort : A review of the literature. *International Journal of Sustainable Built Environment* 5, 1–11. doi:10.1016/j.ijbsbe.2016.03.006
- Alwan, Z., 2016. BIM performance framework for the maintenance and refurbishment of housing stock. *Structural Survey* 34, 242–255. doi:10.1108/SS-03-2015-0018
- Amano, K., Lou, E., 2016. BIM for existing facilities: Feasibility of spectral image integration to 3D point cloud data, in: MATEC Web of Conferences - The 4th International Building Control Conference 2016 (IBCC 2016) 7-8 March. EDP Sciences, Kuala Lumpur, Malaysia, pp. 0–5. doi:10.1051/mateconf/20166600024
- Andrews, D., Bedford, J., Bryan, P., 2015. Metric Survey Specifications for English Heritage.
- Anil, E.B., Tang, P., Akinci, B., Huber, D., 2011. Assessment of Quality of As-is Building

- Information Models Generated from Point Clouds Using Deviation Analysis. Environmental Engineering 7864, 78640F–78640F–13. doi:10.1117/12.876554
- Arayici, Y., 2007. Towards building information modelling for existing structures. Structural Survey 26, 210–222. doi:10.1108/02630800810887108
- Arayici, Y., Counsell, J., Mahdjoubi, L., Nagy, G.A., Hawas, S., Dweidar, K., 2017. Heritage Building Information Modelling, 1st ed. Routledge, Abingdon UK.
- ASHRAE-ANSI, 1989. ANSI/ASHRAE 62-1989 standard.
- Autodesk Forge [WWW Document], 2016. URL <https://forge.autodesk.com/>
- Banfi, F., 2016. Building Information Modelling – A Novel Parametric Modeling Approach Based on 3D Surveys of Historic Architecture, in: Digital Heritage. Progress in Cultural Heritage: Documentation, Preservation, and Protection. pp. 116–127. doi:10.1007/978-3-319-48974-2
- Banfi, F., Fai, S., Brumana, R., 2017. BIM AUTOMATION: ADVANCED MODELING GENERATIVE PROCESS for COMPLEX STRUCTURES. ISPRS Annals of the Photogrammetry, Remote Sensing and Spatial Information Sciences 4, 9–16. doi:10.5194/isprs-annals-IV-2-W2-9-2017
- Barazzetti, L., Banfi, F., Brumana, R., Oreni, D., Previtali, M., Roncoroni, F., 2015. HBIM and augmented information: towards a wider user community of image and range-based reconstructions, in: Yen, Y.-N., Weng, K.-H., Cheng, H.-M. (Eds.), The International Archives of the Photogrammetry, Remote Sensing and Spatial Information Sciences - 25th International CIPA Symposium 2015, 31 August – 04 September. Taipei, Taiwan. doi:10.5194/isprsarchives-XL-5-W7-35-2015
- Becerik-Gerber, B., Jazizadeh, F., Li, N., Calis, G., 2011. Application areas and data requirements for BIM-enabled facilities management. Journal of Construction Engineering and Management 138, 431–442. doi:10.1061/(ASCE)CO.1943-7862.0000433.
- Biagini, C., Capone, P., Donato, V., Facchini, N., 2016. Towards the BIM implementation for historical building restoration sites. Automation in Construction 71, 74–86. doi:10.1016/j.autcon.2016.03.003
- BIMForum, 2018. Level of Development Specification Guide - Draft.

BIMForum, 2016. Level of Development Specification 2013-2016.

BIMForum, 2015. Level of Development Specification.

Bolpagni, M., 2016. THE MANY FACES OF 'LOD' [WWW Document]. URL <http://www.bimthinkspace.com/2016/07/index.html>

BRE, 1985. DIG 297 Surface condensation and mould growth in traditionally-built dwellings. UK.

Brumana, R., Della Torre, S., Oreni, D., Previtali, M., Cantini, L., Barazzetti, L., Franchi, A., Banfi, F., 2017. Hbim Challenge Among the Paradigm of Complexity, Tools and Preservation: the Basilica Di Collemaggio 8 Years After the Earthquake (L'Aquila). ISPRS - International Archives of the Photogrammetry, Remote Sensing and Spatial Information Sciences XLII-2/W5, 97–104. doi:10.5194/isprs-archives-XLII-2-W5-97-2017

Brumana, R., Della Torre, S., Previtali, M., Barazzetti, L., Cantini, L., Oreni, D., Banfi, F., 2018. Generative HBIM modelling to embody complexity (LOD , LOG , LOA , LOI): surveying , preservation , site intervention — the Basilica di Collemaggio (L ' Aquila). Applied Geomatics.

Bruno, S., De Fino, M., Fatiguso, F., 2018. Historic Building Information Modelling: performance assessment for diagnosis-aided information modelling and management. Automation in Construction 86, 256–276. doi:10.1016/j.autcon.2017.11.009

Bruno, S., De Fino, M., Fatiguso, F., 2016. HBIM-aided refurbishment process of Cultural Heritage, in: ISTEa 2016 - BACK TO 4.0: RETHINKING THE DIGITAL CONSTRUCTION INDUSTRY 30/06 e 01/07/2016, Napoli.

Bruno, S., De Fino, M., Fatiguso, F., 2017a. Historic Building Information Modeling towards building diagnostic data management. A case study. TEMA: Technologies, Engineering, Materials and Architecture 3, 99–110. doi:<https://doi.org/10.17410/tema.v3i2.146>

Bruno, S., Dell'Osso, G.R., Fatiguso, F., Modugno, D., 2017b. Quality control of refurbishment project with Building Information Modeling, in: Re-Shaping the Construction Industry. Maggioli Editore, pp. 143–152.

- Bruno, S., Fatiguso, F., 2018. Building conditions assessment of built heritage in historic building information modeling. *International Journal of Sustainable Development and Planning* 13, 36–48. doi:10.2495/SDP-V13-N1-36-48
- BSI, 2014. ISO 9869-1:2014. Thermal insulation-building elements-in-situ measurement of thermal resistance and thermal transmittance. UK.
- BuildingSMARTAlliance, 2015. National BIM Standard - United States® Version 3.
- Cacciotti, R., Blaško, M., Valach, J., 2015. A diagnostic ontological model for damages to historical constructions. *Journal of Cultural Heritage* 16, 40–48. doi:10.1016/j.culher.2014.02.002
- Caffi, V., Daniotti, B., Turco, M. Lo, Madeddu, D., Muscogiuri, M., Novello, P., Pavan, A., Pignataro, M., 2014. “ Il processo edilizio supportato dal BIMM : I ’ approccio InnovANCE ” “ BIMM enabled construction processes : the InnovANCE approach ”, in: ISTeA. Bari, pp. 91–109.
- Canny, J., 1986. A Computational Approach to Edge Detection. *IEEE Transactions on Pattern Analysis and Machine Intelligence PAMI-8*, 679–698. doi:10.1109/TPAMI.1986.4767851
- Chen, Y.-C., Chi, H.-L., Hung, W.-H., Kang, S.-C., 2011. Use of tangible and augmented reality models in engineering graphics courses. *Journal of Professional Issues in Engineering Education and Practice* 137, 267–276. doi:10.1061/(ASCE)EI.1943-5541.0000078
- Cheng, H.-M.H.-M., Yang, W.-B.W.-B., Yen, Y.-N., 2015. BIM applied in historical building documentation and refurbishing, in: Yen, Y.-N., Weng, K.-H., Cheng, H.-M. (Eds.), 25th International CIPA Symposium 2015, 31 August – 04 September 2015. ISPRS - International Archives of the Photogrammetry, Remote Sensing and Spatial Information Sciences, Taipei, Taiwan, pp. 85–90. doi:http://doi.org/10.5194/isprsarchives-XL-5-W7-85-2015
- Chi, H.-L., 2013. Research trends and opportunities of augmented reality applications in architecture, engineering, and construction. *Automation in Construction* 33, 116–122. doi:10.1016/j.autcon.2012.12.017
- Chiabrandò, F., Lo Turco, M., Rinaudo, F., 2017. Modeling the Decay in an Hbim

- Starting From 3D Point Clouds. a Followed Approach for Cultural Heritage Knowledge. ISPRS - International Archives of the Photogrammetry, Remote Sensing and Spatial Information Sciences XLII-2/W5, 605–612. doi:10.5194/isprs-archives-XLII-2-W5-605-2017
- Cho, Y.K., Ham, Y., Golpavar-Fard, M., 2015. 3D as-is building energy modeling and diagnostics: a review of the state-of-the-art. *Advanced Engineering Informatics* 29, 184–195. doi:10.1016/j.aei.2015.03.004
- Christodoulou, S.E., Chari, A., Xanthos, S.S., Kranioti, S., Toxqui, E., 2014. Reliability assessment of BIM-based energy efficiency modeling, in: Ardeshir Mahdavi, Marten, B., Scherer, R. (Eds.), *EWork and EBusiness in Architecture, Engineering and Construction ECPM 2014*. TAYLOR & FRANCIS GROUP, London, pp. 455–460.
- CIBSE, 2011. *KS17: Indoor Air Quality & Ventilation*.
- Cimino, M.G.C.A., Lazzerini, B., Marcelloni, F., Ciaramella, A., 2012. Expert Systems with Applications An adaptive rule-based approach for managing situation-awareness. *Expert Systems With Applications* 39, 10796–10811. doi:10.1016/j.eswa.2012.03.014
- Ciribini, A.L.C., Ventura, S.M., Paneroni, M., 2015. BIM methodology as an integrated approach to heritage conservation management, in: Mahdjoubi, L., Brebbia, C.A., Laing, R. (Eds.), *Building Information Modelling (BIM) in Design, Construction and Operations*. WIT Transactions on The Built Environment, pp. 265–276. doi:10.2495/BIM150231
- Construction Industry Council, 2013. *Employer's Information Requirements Core Content and Guidance Notes*. BIM task Group 1–20. doi:Published by the construction Industry council/BIM TASK GROUP.
- Crespi, P., Franchi, A., Ronca, P., Giordano, N., Scamardo, M., Gusmeroli, G., Schiantarelli, G., 2015. From BIM to FEM: the analysis of an historical masonry building, in: *WIT Transactions on the Built Environment*. WIT Press, pp. 581–592. doi:10.2495/BIM150471
- Cursi, S., Simeone, D., Toldo, I., 2015. A Semantic Web Approach for Built Heritage Representation, in: Celani, G., Sperling, D.M., Franco, J.M.S. (Eds.), 16th

- International Conference, CAAD Futures 2015, July 8-10, 2015. São Paulo, Brazil, pp. 383–401. doi:10.1007/978-3-662-47386-3
- Dang, N.S., Shim, C.S., 2018. BIM authoring for an image-based bridge maintenance system of existing cable-supported bridges. IOP Conference Series: Earth and Environmental Science 143. doi:10.1088/1755-1315/143/1/012032
- De Angelis, E., Ciribini, A.L.C., Tagliabue, L.C., Paneroni, M., 2015. The Brescia smart campus demonstrator. Renovation toward a zero energy classroom building. Procedia Engineering 118, 735–743. doi:10.1016/j.proeng.2015.08.508
- De Fino, M., Sciotti, A., Rubino, R., Pierucci, A., Fatiguso, F., 2018. ‘Augmented Diagnostics’ for the Architectural Heritage. International Journal of Heritage Architecture 2, 248–260. doi:10.2495/HA-V2-N2-248-260
- Del Giudice, M., Osello, A., 2013. BIM for cultural heritage, in: Grussenmeyer, P. (Ed.), XXIV International CIPA Symposium, 2 – 6 September 2013. International Archives of the Photogrammetry, Remote Sensing and Spatial Information Sciences - ISPRS Archives, Strasbourg, France, pp. 225–229. doi:https://doi.org/10.5194/isprsarchives-XL-5-W2-103-2013, 2013
- Deng, X., Gao, Q., Zhang, C., Hu, D., Yang, T., 2017. Rule - based Fault Diagnosis Expert System for Wind Turbine. ITM Web of Conferences 11, 1–9. doi:10.1051/itmconf/20171107005
- Dhule, J.J., Dhurpate, N.B., Gonge, S.S., Kandalkar, G.M., 2016. Edge Detection Technique Used for Identification of Cracks on Vertical Walls of the Building. 2015 International Conference on Computing and Network Communications, CoCoNet 2015 263–268. doi:10.1109/CoCoNet.2015.7411196
- Di Giuda, G.M., Villa, V., Piantanida, P., 2015. BIM and energy efficient retrofitting in school buildings. Energy Procedia 78, 1045–1050. doi:10.1016/j.egypro.2015.11.066
- Di Lorenzo, A., 2015. Integration of diagnostic survey in BIM for existing buildings. Polytechnic University of Bari.
- Díaz, J., Baier, C., 2016. BIM in der Planung: Verbesserung im gesamten Lebenszyklus (BIM in planning: improvement in the entire lifecycle). GeoResources Zeitschrift

2, 5–6.

Document E202™ – 2008 Building Information Modeling Protocol Exhibit, 2008.

Dong, B., Neill, Z.O., Li, Z., 2014. A BIM-enabled information infrastructure for building energy fault detection and diagnostics. *Automation in Construction* 44, 197–211. doi:10.1016/j.autcon.2014.04.007

Dore, C., 2017. Procedural Historic Building Information Modelling (HBIM) For Recording and Documenting European Classical Architecture 324.

Dore, C., Murphy, M., 2013. Semi-automatic modelling of building façades with shape grammars using historic building information modelling, in: J. Boehm, Remondino, F., Kersten, T., Fuse, T., Gonzalez-Aguilera, D. (Eds.), *International Archives of the Photogrammetry, Remote Sensing and Spatial Information Sciences 3D-ARCH 2013 - 3D Virtual Reconstruction and Visualization of Complex Architectures*, 25 – 26 February. ISPRS Archives, Trento, Italy, pp. 57–64. doi:10.5194/isprsarchives-XL-5-W1-57-2013

Dore, C., Murphy, M., 2012. Integration of Historic Building Information Modeling (HBIM) and 3D GIS for Recording and Managing Cultural Heritage Sites, in: Guidi, G., Addison, A.C. (Eds.), *18th International Conference on Virtual Systems and Multimedia (VSMM): Virtual Systems in the Information Society & Applications to Heritage*, 2-5 September 2012. IEEE, Milan, Italy, pp. 369–376. doi:10.1109/VSSMM.2012.6365947

Dwairi, S. and Mahdjoubi, L. 'Development of OntEIR Framework to Support Heritage Clients'. In *Heritage Building Information Modelling*, edited by Taylor & Francis, 257–68, 2016.

Eastman, C.M., 2016. Cloud-based BIM Data Transmission: Current Status and Challenges Cloud-based BIM Data Transmission: Current Status and Challenges. *33rd International Symposium on Automation and Robotics in Construction (ISARC 2016)*.

Eastman, C.M.C., Teicholz, P., Sacks, R., Liston, K., 2011. *BIM Handbook: A Guide to Building Information Modeling for Owners, Managers, Designers, Engineers and Contractors*, 2nd Ed. ed. John Wiley & Sons, Inc., New Jersey.

- Ehrig, K., Goebels, J., Meinel, D., Paetsch, O., Prohaska, S., Zobel, V., 2009. Comparison of Crack Detection Methods for Analyzing Damage Processes in Concrete with Computed Tomography. International Symposium on Digital Industrial Radiology and Computed Tomography 1–8.
- EN 16096:2012 European Technical Committee TC 346, 2012. EN 16096:2012 - Conservation of cultural property - Condition survey and report of built cultural heritage.
- Eschmann, C., Kuo, C.-M., Kuo, C.-H., Boller, C., 2013. Unmanned Aircraft Systems for Remote Building Inspection and Monitoring, in: Boller, C. (Ed.), European Workshop on Structural Health Monitoring - EWSHM 2012, 3-6 July. Dresden, Germany.
- Fabozzi, G., 2007. Executive project Augustinian Monastery, Trani.
- Fai, S., Graham, K., Duckworth, T., Wood, N., Attar, R., 2011. Building Information Modelling and heritage documentation, in: Pavelka, K. (Ed.), XXIIIrd International CIPA Symposium September 12 - 16, 2011. Prague, Czech Republic,.
- FARO, 2018. As-Built for Revit.
- Fatiguso, F., De Fino, M., Sciotti, A., 2017. Performance Assessment Of Italian School Heritage Architecture By Non-destructive Investigation. International Journal of Heritage Architecture 1, 564–579. doi:10.2495/HA-V1-N4-564-579
- Fatiguso, F., De Fino, M., Sciotti, A., 2016. Performance Assessment Of Italian School Heritage Architecture By Non-destructive Investigation. International Journal of Heritage Architecture 1.
- Forte, M., Pescarin, S., Pietroni, E., Dell'Unto, N., 2004. An Integrated Approach to Archaeology: From the Fieldwork to Virtual Reality Systems, in: Nicolucci, F., Hermon, S. (Eds.), Proceedings of CAA2004, Prato 13–17 April 2004. Archaeolingua, Budapest, Hungary.
- Galantucci, R.A., Fatiguso, F., Galantucci, L.M., 2018. A proposal for a new standard quantification of damages of cultural heritages, based on 3D scanning. Scientific REsearch and Information Technology (SCIRESit). doi:http://dx.doi.org/10.2423/i22394303v8n1p121

- Gärtner, B., Hoffmann, M., 2013. Computational Geometry Lecture Notes HS 2013. Zurich.
- Gerrish, T., Ruikar, K., Cook, M., Johnson, M., Phillip, M., Lowry, C., 2017. BIM application to building energy performance visualisation and management Challenges and potential. *Energy and Buildings* 144, 218–228. doi:10.1016/j.enbuild.2017.03.032
- Gerrish, T., Ruiker, K., Cook, M., Johnson, M., Phillip, M., 2015. Attributing in-use building performance data to an as-built building information model for lifecycle building performance management, in: Beetz, J., van Berlo, L., Hartmann, T., Amor, R. (Eds.), *Proceedings of the 32nd CIB W78 Conference, 27-29 October 2015*. CIB, Eindhoven, The Netherlands, p. 10 pp.
- Goulding, J.J.S., Rahimian, F.P.F., Wang, X., 2014. Virtual reality-based cloud BIM platform for integrated AEC projects. *Journal of Information Technology in Construction* 19, 308–325.
- Grosan, C., Abraham, A., Alii, E., 2011. *Intelligent systems. A Modern Approach*. Springer-Verlag Berlin Heidelberg. doi:10.1007/978-3-642-21004-4
- GSA-U.S. General Services Administration, 2007. BIM Technical Standards: Minimum Attributes [WWW Document]. URL <https://www.gsa.gov/real-estate/design-construction/3d4d-building-information-modeling/bim-guidelines-for-revit/guidelines/technical-standards/bim-technical-standards-minimum-attributes>
- Gupta, S., Ghosh Mazumdar, S., 2012. Sobel Edge Detection Algorithm. *International Journal of Computer Science and Management Research* 2, 1578–1583.
- Habibi, S., 2017. The promise of BIM for improving building performance. *Energy and Buildings* 153, 525–548. doi:10.1016/j.enbuild.2017.08.009
- Ham, Y., Golparvar-Fard, M., 2015. BIM and thermographic sensing: reflecting the as-is building condition in energy analysis. *Journal of Construction Engineering and Project Management* 5, 16–22. doi:10.6106/JCEPM.2015.5.4.016
- Ham, Y., Han, K.K., Lin, J.J., Golparvar-Fard, M., 2016. Visual monitoring of civil infrastructure systems via camera-equipped Unmanned Aerial Vehicles (UAVs): a

review of related works. *Visualization in Engineering* 4, 1. doi:10.1186/s40327-015-0029-z

Haugbotn, A., 2015. Georadar til utenomhus BIM: prinsipper og praktisk anvendelser (Georadar in BIM for outdoor environment: principles and practice), in: Konferanse 2015 “Løfter Bae-Næringen” (Conference 2015, Promises in the Construction Industry). Oslo, Norway.

HBIM Portal-Smart Heritage Building performance measurement for sustainability [WWW Document], 2016. URL <http://www.hbim.org/web-portal/>

Hichri, N., Stefani, C., De Luca, L., Veron, P., Hamon, G., 2013. From Point Cloud To Bim: a Survey of Existing Approaches, in: ISPRS - International Archives of the Photogrammetry, Remote Sensing and Spatial Information Sciences, XXIV International CIPA Symposium. Strasbourg, France, pp. 343–348. doi:10.5194/isprsarchives-XL-5-W2-343-2013

Historic England, 2017. BIM for Heritage 78.

HM Government, 2015. 3-Digital Built Britain Level 3 Building Information Modelling - Strategic Plan. UK Government 1–47. doi:URN BIS/15/155

Ilomets, S., Kalamees, T., 2016. Evaluation of the criticality of thermal bridges. *Journal of Building Pathology and Rehabilitation* 1, 11. doi:10.1007/s41024-016-0005-6

Iltter, D., Ergen, E., 2015. BIM for building refurbishment and maintenance: current status and research directions. *Structural Survey* 33, 228–256. doi:10.1108/SS-02-2015-0008

ISCARSAH (International Scientific Committee for Analysis and Restoration of Structures of Architectural Heritage), 2003. Recommendations for the analysis, conservation and structural restoration of Architectural Heritage. Icomos 3–6.

Ishizuka, M., Fu, K., Yao, J.T.P., National, T., Foundation, S., 1981. RULE-BASED DAMAGE ASSESSMENT OF EXISTING STRUCTURES.

ISO/TC184/SC4, 2013. ISO 16739:2013 Industry Foundation Classes (IFC) for data sharing in the construction and facility management industries.

ISO/TC59/SC13, 2016. ISO 29481-1:2016 “Building information modelling -

Information delivery manual - Part 1: Methodology and format”.

ISO/TC59/SC13, 2007. ISO 12006-3:2007 Building construction - Organization of information about construction works - Part 3: Framework for object-oriented information.

Jacobs, G., 2014. 3D laser scanning boosts BIM [WWW Document]. The Global Magazine of Leica Geosystems. URL <https://blog.leica-geosystems.com/3d-laser-scanning-boosts-bim/>

Jafari, M.J., Khajevandi, A.A., Mousavi Najarkola, S.A., Yekaninejad, M.S., Pourhoseingholi, M.A., Omid, L., Kalantary, S., 2015. Association of Sick Building Syndrome with Indoor Air Parameters. *Tanaffos* 14, 55–62.

Jeong, S., Byun, J., Kim, D., Sohn, H., Bae, I.H., Law, K.H., n.d. A Data Management Infrastructure for Bridge Monitoring.

Jiang, Y., Liu, X., Liu, F., Wu, D., Anumba, C., 2016. An Analysis of BIM Web Service Requirements and Design to Support Energy Efficient Building Lifecycle. *Buildings* 6, 20. doi:10.3390/buildings6020020

Jiménez Fernández-Palacios, B., Morabito, D., Remondino, F., 2016. Access to complex reality-based 3D models using virtual reality solutions. *Journal of Cultural Heritage*. doi:10.1016/j.culher.2016.09.003

Jung, J., Hong, S., Jeong, S., Kim, S., Cho, H., Hong, S., Heo, J., 2014. Productive modeling for development of as-built BIM of existing indoor structures. *Automation in Construction* 42, 68–77. doi:10.1016/j.autcon.2014.02.021

Kassem, M., Kelly, G., Dawood, N., Serginson, M., Lockley, S., 2015. BIM in facilities management applications: a case study of a large university complex. *Built Environment Project and Asset Management* 5, 261–277. doi:10.1108/BEPAM-02-2014-0011

Khaddaj, M., Srour, I., 2016. Using BIM to retrofit existing buildings. *Procedia Engineering* 145, 1526–1533. doi:10.1016/j.proeng.2016.04.192

Khodeir, L.M., 2016. Integrating HBIM (heritage building information modeling) tools in the application of sustainable retrofitting of heritage buildings in Egypt. *Procedia Environmental Sciences* 34, 258–270. doi:10.1016/j.proenv.2016.04.024

- Kosmina, L., 2016. In-situ measurement of U-value. Guide to In-situ U-value measurement of walls in existing dwellings In-situ 1–13.
- Laefer, D.F., Zahiri, Z., Gowen, A., 2018. Using Short-wave Infrared Range Spectrometry Data to Determine Brick Characteristics. *International Journal of Architectural Heritage* 00, 1–13. doi:10.1080/15583058.2018.1503362
- Lagüela, S., Díaz-Vilariño, L., Armesto, J., Arias, P., 2012. Thermographic 3D models as the foundation for Building Information Models, in: Cardone, G. (Ed.), 11th International Conference on Quantitative InfraRed Thermography, 7-11 July. Naples, Italy. doi:10.21611/qirt.2012.180
- Lecun, Y., Bengio, Y., Hinton, G., 2015. Deep learning. *Nature* 521, 436–444. doi:10.1038/nature14539
- Lee, J., Lee, J., Kim, J.W., Kang, K., Lee, M.H., 2016. Virtual reconstruction and interactive applications for Korean traditional architectures. *SCIRES-IT - SCientific REsearch and information Technology* 6, 5–14. doi:10.2423/122394303V6N1P5
- Liu, Y., 2016. Robust segmentation of raw point clouds into consistent surfaces. *Science China Technological Sciences* 59, 1156–1166. doi:10.1007/s11431-016-6072-8
- Logothetis, S., Delinasiou, A., Stylianidis, E., 2015. Building Information Modelling for Cultural Heritage: A review. *ISPRS Annals of Photogrammetry, Remote Sensing and Spatial Information Sciences II-5/W3*, 177–183. doi:10.5194/isprsannals-II-5-W3-177-2015
- Logothetis, S., Karachaliou, E., Stylianidis, E., 2017. From OSS CAD to BIM for cultural heritage digital representation, in: Aguilera, D., Georgopoulos, A., Kersten, T., Remondino, F., Stathopoulou, E. (Eds.), *The International Archives of the Photogrammetry, Remote Sensing and Spatial Information Sciences - 3D Virtual Reconstruction and Visualization of Complex Architectures*, 1–3 March. Nafplio, Greece, pp. 1–3. doi:10.5194/isprs-archives-XLII-2-W3-439-2017
- López, F., Lerones, P., Llamas, J., Gómez-García-Bermejo, J., Zalama, E., 2018. A Review of Heritage Building Information Modeling (H-BIM). *Multimodal Technologies and Interaction* 2, 21. doi:10.3390/mti2020021

- López, F.J., Leronés, P.M., Llamas, J., Gómez-García-Bermejo, J., Zalama, E., 2017. A framework for using point cloud data of Heritage buildings towards geometry modeling in a BIM context: a case study on Santa Maria la Real de Mave Church. *International Journal of Architectural Heritage* 3058, 15583058.2017.1325541. doi:10.1080/15583058.2017.1325541
- Macher, H., Landes, T., Grussenmeyer, P., Alby, E., 2014. Semi-automatic segmentation and modelling from point clouds towards historical building information modelling, in: *Lecture Notes in Computer Science (Including Subseries Lecture Notes in Artificial Intelligence and Lecture Notes in Bioinformatics)*. doi:10.1007/978-3-319-13695-0
- Mahamadu, A.-M., 2017. Development of a decision support framework to aid selection of construction supply chain organisations for BIM-enabled projects.
- Marzouk, M., Abdelaty, A., 2014. BIM-based framework for managing performance of subway stations. *World Transit Research*. doi:10.1016/j.autcon.2014.02.004
- Maxwell, I., 2016a. Part 1: Conservation Parameters. COTAC BIM4C Integrating HBIM Framework Report 33.
- Maxwell, I., 2016b. Part 2: Conservation Influences, COTAC BIM4C Integrating HBIM Framework Report.
- Maxwell, I., 2014. Integrating Digital Technologies in Support of Historic Building Information Modelling: BIM4Conservation (HBIM) - A COTAC Report.
- May, N., Sanders, C., 2017. Moisture in buildings : an integrated approach to risk assessment and guidance.
- McArthur, J.J., 2015. A Building Information Management (BIM) Framework and Supporting Case Study for Existing Building Operations, Maintenance and Sustainability. *Procedia Engineering* 118, 1104–1111. doi:10.1016/j.proeng.2015.08.450
- Meadati, P., Javier, I., Akhnouk, A.K., 2010. BIM and RFID integration : A pilot study, in: *Second International Conference on Construction in Developing Countries (ICCIDC-II) "Advancing and Integrating Construction Education, Research & Practice"* 3-5 August 2010. Cairo, Egypt.

- Megahed, N.A., 2015. Towards a Theoretical Framework for HBIM Approach in Historic Preservation and Management. *International Journal of Architectural Research* 9, 130–147.
- Messaoudi, T., Véron, P., Halin, G., De Luca, L., 2018. An ontological model for the reality-based 3D annotation of heritage building conservation state. *Journal of Cultural Heritage* 29, 100–112. doi:10.1016/j.culher.2017.05.017
- Messner, J., Anumba, C., Dubler, C., Goodman, S., Kasprzak, C., Kreider, R., Leicht, R., Saluja, C., Zikic, N., 2011. BIM Project Execution Planning Guide - Version 2.1. buildingSMART alliance 1–135. doi:10.1017/CBO9781107415324.004
- Modugno, D., Dell'Osso, G.R., Bruno, S., 2016. The survey of the built environment within BIM approach - Il rilievo del costruito nel BIM. Polytechnic University of Bari.
- Mohan, A., Poobal, S., 2017. Crack detection using image processing : A critical review and analysis. *Alexandria Engineering Journal*. doi:10.1016/j.aej.2017.01.020
- Murphy, M., McGovern, E., Pavia, S., 2013. Historic building information modelling - adding intelligence to laser and image based surveys of European classical architecture. *ISPRS Journal of Photogrammetry and Remote Sensing* 76, 89–102. doi:10.1016/j.isprsjrs.2012.11.006
- Murphy, M., McGovern, E., Pavia, S., 2009. Historic building information modelling (HBIM). *Structural Survey* 27, 311–327. doi:10.1108/02630800910985108
- Musicco, A., 2017. 4D - HBIM for the digital information management of knowledge and qualification of historical buildings. Polytechnic University of Bari.
- National BIM Standard - United States® Version 3, Chapter 5 - Practice Documents, 2015.
- Nisbet, N., Cartwright, J., Aizlewood, M., 2016. Energy modelling of existing facilities, in: Symeon Christodoulou, Scherer, R. (Eds.), *EWork and EBusiness in Architecture, Engineering and Construction - Proceedings of the 11th European Conference on Product and Process Modelling, ECPPM 2016, 7-9 September*. Limassol, Cyprus.
- Oreni, D., Brumana, R., Banfi, F., Bertola, L., Barazzetti, L., Cuca, B., Previtali, M.,

- Roncoroni, F., 2014a. Beyond crude 3D models: from point clouds to historical building information modeling via NURBS, in: *Lecture Notes in Computer Science (Including Subseries Lecture Notes in Artificial Intelligence and Lecture Notes in Bioinformatics)*. doi:10.1007/978-3-319-13695-0
- Oreni, D., Brumana, R., Della Torre, S., Banfi, F., Barazzetti, L., Previtali, M., 2014b. Survey turned into HBIM: the restoration and the work involved concerning the Basilica di Collemaggio after the earthquake (L'Aquila), in: *ISPRS Annals of the Photogrammetry, Remote Sensing and Spatial Information Sciences*. doi:10.5194/isprsannals-II-5-267-2014
- Oreni, D., Brumana, R., Georgopoulos, A., Cuca, B., 2013. HBIM for conservation and management of built heritage: towards a library of vaults and wooden beam floors, in: Grussenmeyer, P. (Ed.), *ISPRS Annals of Photogrammetry, Remote Sensing and Spatial Information Sciences, II-5/W1 XXIV International CIPA Symposium 2-6 September 2013. Strasbourg, France*, pp. 215–221. doi:10.5194/isprsannals-II-5-W1-215-2013
- PAS 1192-2, 2013. PAS 1192-2:2013 Specification for information management for the capital/delivery phase of construction projects using building information modelling.
- PAS 1192-3, 2014. PAS 1192-3, Specification for information management for the operational phase of assets using building information modelling Publishing and copyright information.
- Pauwels, P., Verstraeten, R., De Meyer, R., Van Campenhout, J., 2008. Architectural Information Modelling for Virtual Heritage Application, in: Ioannides, M., Addison, A., Georgopoulos, A., Kalisperis, L. (Eds.), *Digital Heritage – Proceedings of the 14th International Conference on Virtual Systems and Multimedia. Archaeolingua, Budapest, Hungary*, pp. 18–23.
- Pavlovskis, M., Antucheviciene, J., Migilinskas, D., 2017. Assessment of buildings redevelopment possibilities using MCDM and BIM techniques. *Procedia Engineering* 172, 846–850. doi:10.1016/j.proeng.2017.02.083
- Pocobelli, D.P., Boehm, J., Bryan, P., Still, J., England, H., 2018a. Building Information Models for Monitoring and Simulation Data, in: *ISPRS TC II Mid-Term Symposium "Towards Photogrammetry 2020". Riva del Garda, Italy*, pp. 4–7.

- Pocobelli, D.P., Boehm, J., Bryan, P., Still, J., Grau-Bové, J., 2018b. BIM for heritage science: a review. *Heritage Science* 6, 23–26. doi:10.1186/s40494-018-0191-4
- Polishape srl, BReD srl, Polytechnic of Bari, University of Naples, 2014. Project PAC02L2_00101 (2014-2016):"Contactless diagnostic system by augmented reality for cultural heritage with low accessibility" - Funding Program MIUR START-UP - Augmented Impact Culture.
- Prasanna, P., Dana, K., Gucunski, N., Basily, B., Hung, Ronny, 2016. Automated Crack Detection on Concrete Bridges. *IEEE Transactions on Automation Science and Engineering*.
- Prizeman, O.E.C., 2015. HBIM and matching techniques: considerations for late nineteenth- and early twentieth-century buildings. *Journal of Architectural Conservation* 21. doi:10.1080/13556207.2016.1139852
- Qu, Z., Ju, F., Guo, Y., Bai, L., Chen, K., 2018. Concrete surface crack detection with the improved pre-extraction and the second percolation processing methods (2018) Concrete surface crack detection with the improved pre-extraction and the second percolation processing methods. *PLOS ONE* 13(7): e020110. *PLOS ONE* 13. doi:https://doi.org/10.1371/journal.pone.0201109
- Quattrini, R., Malinverni, E.S., Clini, P., Nespeca, R., Orlietti, E., 2015. From tIs to hbim. high quality semantically-aware 3d modeling of complex architecture, in: Gonzalez-Aguilera, D., Remondino, F., Boehm, J., Kersten, T., Fuse, T. (Eds.), *International Archives of the Photogrammetry, Remote Sensing and Spatial Information Sciences - 3D Virtual Reconstruction and Visualization of Complex Architectures* 25-27 February. *ISPRS Archives*, Avila, Spain, pp. 367–374. doi:10.5194/isprsarchives-XL-5-W4-367-2015
- Quattrini, R., Pierdicca, R., Morbidoni, C., 2017. Knowledge-based data enrichment for HBIM: Exploring high-quality models using the semantic-web. *Journal of Cultural Heritage*. doi:10.1016/j.culher.2017.05.004
- Rahmat, 1997. *The Planning and Control Process of Refurbishment Projects*. University College London.
- Rechichi, F., Mandelli, A., Achille, C., Fassi, F., 2016. SHARING HIGH-RESOLUTION MODELS AND INFORMATION ON WEB : THE WEB MODULE OF BIM3DSG

SYSTEM XLI, 12–19. doi:10.5194/isprsarchives-XLI-B5-703-2016

- Remondino, F., Niederoest, J., 2004. Generation of High-Resolution Mosaic for Photo-Realistic Texture-Mapping of Cultural Heritage 3D Models, in: Chrysanthou, Y., Cain, K., Silberman, N., Niccolucci, F. (Eds.), VAST 2004: The 5th International Symposium on Virtual Reality, Archaeology and Cultural Heritage. The Eurographics Association. doi:10.2312/VAST/VAST04/085-092
- Rio, J., Ferrera, B., Pocas-Martins, J., 2013. Expansion of IFC model with structural sensors. *Informes de la Construcción (Report on construction)* 65, 219–228.
- Rodríguez-Moreno, C., Reinoso-Gordo, J.F., Rivas-López, E., Gómez-Blanco, A., Ariza-López, F.J., Ariza-López, I., 2016. From point cloud to BIM: an integrated workflow for documentation, research and modelling of architectural heritage. *Survey Review*. doi:10.1080/00396265.2016.1259719
- Sampaio, A.Z., Simões, D., 2014. Maintenance of buildings using BIM methodology. *The Open Construction and Building Technology Journal* 337–342.
- Seeam, A., Zheng, T., Lu, Y., Usmani, A., Laurenson, D., 2013. BIM integrated workflow management and monitoring system for modular buildings. *International Journal of 3-D Information Modeling*. doi:10.4018/ij3dim.2013010103
- Shi, Z., Abdelalim, A., O'Brien, W., Attar, R., Akiki, P., Graham, K., Waarden, B. Van, Fai, S., Tessier, A., Khan, A., 2015. Digital Campus Innovation Project: Integration of Building Information Modelling with Building Performance Simulation and Building Diagnostics, in: *Proceedings of the Symposium on Simulation for Architecture & Urban Design (SimAUD '15)*.
- Shi, Z., O'Brien, W., Abdelalim, A., 2016. a Web-Based Interactive 3D Visualization Tool for Building Data. *eSim2016*.
- ShortLiffe, E., 1976. *Computer-Based Medical Consultations:MYCIN*. American Elsevier.
- Siebert, S., Teizer, J., 2014. Mobile 3D mapping for surveying earthwork projects using an Unmanned Aerial Vehicle (UAV) system. *Automation in Construction* 41, 1–14. doi:10.1016/j.autcon.2014.01.004
- Sierra, F., Mahdjoubi, L., Gething, B., Alzaatreh, A., Fitton, R., Marshall, A., 2018.

- Comparison of prediction tools to determine their reliability on calculating operational heating consumption by monitoring no-fines concrete dwellings. *Energy and Buildings* 176, 78–94. doi:10.1016/j.enbuild.2018.07.012
- Simmhan, Y., Aman, S., Kumbhare, A., Liu, R., Stevens, S., Zhou, Q., Prasanna, V., 2013. Cloud-based software platform for big data analytics in smart grids. *Computing in Science & Engineering* 15, 38–47. doi:10.1109/MCSE.2013.39
- Smarsly, K., Tauscher, E., 2016. Monitoring information modeling for semantic mapping of structural health monitoring systems, in: Yabuki, N., Makanae, K. (Eds.), *The 16th International Conference on Computing in Civil and Building Engineering (ICCCBE)*. Osaka, Japan.
- Sobel, E., 1970. *Camera Models and Machine Perception*. Stanford University, Stanford, California.
- Sousa, H.S., Prieto-Castrillo, F., Matos, J.C., Branco, J.M., Lourenço, P.B., 2018. Combination of expert decision and learned based Bayesian Networks for multi-scale mechanical analysis of timber elements. *Expert Systems with Applications* 93, 156–168. doi:10.1016/j.eswa.2017.09.060
- Sternal, M., Dragos, K., 2014. BIM-BASED MODELING OF STRUCTURAL HEALTH MONITORING SYSTEMS USING THE IFC STANDARD [WWW Document]. <https://smarsly.files.wordpress.com>. URL <https://smarsly.files.wordpress.com/2016/07/dragos2016a.pdf>
- Succar, B., 2010. Building Information Modelling Maturity Matrix. doi:10.4018/978-1-60566-928-1.ch004
- Succar, B., 2009. Building information modelling framework: A research and delivery foundation for industry stakeholders. *Automation in Construction* 18, 357–375. doi:10.1016/j.autcon.2008.10.003
- Thabet, W., Lucas, J., Johnston, S., 2016. A Case Study for Improving BIM-FM Handover for a Large Educational Institution, in: *Construction Research Congress 2016*. Downloaded. pp. 2139–2148. doi:<https://doi.org/10.1061/9780784479827.217>
- Torok, M.M., Golparvar-Fard, M., Kochersberger, K.B., 2014. Image-Based Automated

- 3D Crack Detection for Post-disaster Building Assessment. *Journal of Computing in Civil Engineering* 28, A4014004. doi:10.1061/(ASCE)CP.1943-5487.0000334
- UNI/CT033/GL05, 2017. UNI 11337-3-2017-Codification Criteria for Construction Products and Processes.
- UNI/CT033, 2017. UNI 11337-4:2017 Edilizia e opere di ingegneria civile - Gestione digitale dei processi informativi delle costruzioni - Parte 4: Evoluzione e sviluppo informativo di modelli, elaborati e oggetti (Construction and civil engineering works: Digital management).
- USIBD, 2016. Level Of Accuracy (LOA) Specification Version 2.0.
- Vacanas, Y., Themistocleous, K., Agapiou, A., Hadjimitsis, D., 2015. Building Information Modelling (BIM) and Unmanned Aerial Vehicle (UAV) technologies in infrastructure construction project management and delay and disruption analysis, in: Hadjimitsis, D.G., Themistocleous, K., Michaelides, S., Papadavid, G. (Eds.), *Third International Conference on Remote Sensing and Geoinformation of the Environment (Rscy2015)*, 16-19 March. Paphos, Cyprus, p. 95350C. doi:10.1117/12.2192723
- Valero, E., Adan, A., Cerrada, C., 2014. Evolution of RFID Applications in Construction: A Literature Review, in: Hervás, R., Lee, S., Nugent, C., Bravo, J. (Eds.), *International Conference on Ubiquitous Computing and Ambient Intelligence - UCAmI 2014: Ubiquitous Computing and Ambient Intelligence. Personalisation and User Adapted Services 2-5 December, 2014*. Springer International Publishing, Belfast, UK, pp. 191–199. doi:10.1007/978-3-319-13102-3_32
- Vicente, R., Ferreira, T.M., Mendes da Silva, J.A.R., 2015. Supporting urban regeneration and building refurbishment. Strategies for building appraisal and inspection of old building stock in city centres. *Journal of Cultural Heritage* 16, 1–14. doi:10.1016/j.culher.2014.03.004
- Volk, R., Stengel, J., Schultmann, F., 2014. Building Information Modeling (BIM) for existing buildings - Literature review and future needs. *Automation in Construction* 38, 109–127. doi:10.1016/j.autcon.2013.10.023
- Wang, B., Á, T.T., Yamasaki, Y., Sakano, N., Wang, D., Ogino, K., 2008. Symptom definitions for SBS (sick building syndrome) in residential dwellings 211, 114–

120. doi:10.1016/j.ijheh.2007.03.004

- Wang, C., Cho, Y.K., Kim, C., 2015. Automatic BIM component extraction from point clouds of existing buildings for sustainability applications. *Automation in Construction* 56, 1–13. doi:10.1016/j.autcon.2015.04.001
- Wang, E., Barryman, C., 2011. A Building LCA case study using Autodesk Ecotect and BIM model. *DigitalCommons@University of Nebraska - Lincoln Papers*.
- Wefelscheid, C., Hänsch, R., Hellwich, O., 2012. THREE-DIMENSIONAL BUILDING RECONSTRUCTION USING IMAGES OBTAINED BY UNMANNED AERIAL VEHICLES. *ISPRS - International Archives of the Photogrammetry, Remote Sensing and Spatial Information Sciences* 183–188. doi:10.5194/isprsarchives-XXXVIII-1-C22-183-2011
- Westoby, M.J., Brasington, J., Glasser, N.F., Hambrey, M.J., Reynolds, J.M., 2011. 'Structure-from-Motion': a high resolution, low-cost photogrammetric tool for geoscience applications. *Geomorphology*. 'Structure-from-Motion' photogrammetry: A low-cost, effective tool for geoscience applications. *Geomorphology*. doi:10.1016/j.geomorph.2012.08.021
- Williams, G., Gheisari, M., Chen, P.-J., Irizarry, J., 2015. BIM2MAR: an efficient BIM translation to mobile augmented reality applications. *Journal of Management in Engineering* 31, A4014009. doi:10.1061/(ASCE)ME.1943-5479.0000315
- Woo, J.-H., Menassa, C., 2014. Virtual retrofit model for aging commercial buildings in a smart grid environment. *Energy and Buildings* 80, 424–435. doi:10.1016/j.enbuild.2014.05.004
- Ye, S., Nourzad, S.H.H., Pradhan, A., Bartoli, I., Kontsos, A., 2014. Automated Detection of Damaged Areas after Hurricane Sandy using Aerial Color Images, in: *International Conference on Computing in Civil and Building Engineering*. American Society of Civil Engineers, Reston, VA, pp. 1796–1803. doi:10.1061/9780784413616.223
- Zainudin, H., Haron, N.A., Bachek, S.H., Jusoh, A., 2016. Utilization of Building Information Modeling (BIM) in Planning an Adaptive Reuse Project of a Traditional Malay House (TMH), in: Thwaites, H., Lancaster, L. (Eds.), *22nd International Conference on Virtual System & Multimedia (VSMM 2016)*. IEEE, Kuala Lumpur,

Malaysia, pp. 1–7. doi:10.1109/VSMM.2016.7863193

Zhang, Y., Bai, L., 2015. Rapid structural condition assessment using radio frequency identification (RFID) based wireless strain sensor. *Automation in Construction* 54, 1–11. doi:10.1016/j.autcon.2015.02.013

Zhao, P., Suryanarayanan, S., Simoes, M.G., 2013. An Energy Management System for Building Structures Using a Multi-Agent Decision-Making Control Methodology, in: *IEEE Industry Applications Society Annual Meeting*. IEEE, São Paulo, Brazil, pp. 1–8. doi:10.1109/IAS.2010.5615412

ACKNOWLEDGEMENTS

I must declare that the support of supervisors of this PhD Thesis has been solid and frequent, thus I am glad to thank Prof. Fabio Fatiguso, Prof. Guido Raffaele Dell'Osso and Prof. Lamine Madjoubi. They contributed in different ways in developing this adventure of three years. Prof. Fabio Fatiguso firstly imparted me the interest in refurbishing, and gave me the possibility to investigate historic buildings presented in this dissertation. He provided important advises for conducting the thesis. Prof. Guido Dell'Osso sincerely supported me with critical and farsighted suggestions that I have actually appreciated. Prof. Lamine Mahdjoubi trusted me when he accepted to cooperate to this thesis and I am pleased to offer my contribution to the HBIM project.

A further recognition is directed to PhD Ing. Mariella De Fino and Rocco Rubino for their availability in improving the proposed methodology and providing equipment and technical competences in the execution of diagnostic tests, as BRED srl.

I extend my appreciation for the collaboration with the genius of information systems Ammar, and Prof. Bill Gething, Francisco and Abdul for their warm welcome in the cold Bristol.

In addition, I am grate with the Master students who investigated the BIM and HBIM in their Master thesis, believing in the potential of the current research in professional perspective (Anna, Noemi, Gabriella, Domenico, Enrico, Davide, Cinzia, Patrizia, Antonella, Giacomo, Mariabruna, Giuseppe).

I am grateful with my original family and acquired family, made up of my boyfriend Michele, and his parents Isa and Mimmo.

A sweet memory of my PhD colleagues, Diana, Giulia, Carmine, Valentino, Silvia, Corrado, Viviana with which I spent very enjoyable time, beyond the work commitments.

LIST OF FIGURES

| | |
|---|----|
| Figure 1.2-1 UNI 11337-3-2017 draft of the proposed LoG-Lol ('F and G'). Source: (Brumana et al., 2017) | 23 |
| Figure 1.2-2 CIC BIM Cyclical Diagram and COTAC HBIM Cyclical Diagram. Source: (Maxwell, 2016a) | 27 |
| Figure 1.2-3 Application of Historic England Conservation Principles (Maxwell, 2016a)..... | 29 |
| Figure 2.1-1 Literature review methodology. Source: author. | 34 |
| Figure 2.2-1 Trend of published papers and contributions in BIM for existing buildings, from 2007 to 2017. Source: author. | 38 |
| Figure 2.4-1 Level of automation from reverse engineering to HBIM. Source: author | 50 |
| Figure 2.4-2 Processes from data acquisition to BIM. Source: author. | 51 |
| Figure 2.4-3 New approaches for optimising energy simulations. Source: author. | 58 |
| Figure 2.4-4 Trends in diagnostics and monitoring in BIM for refurbishment of existing building, rehabilitation of infrastructures and general applications. Source: author.... | 62 |
| Figure 3.1-1 Structuration of the DA-HBIMM methodology. Source: author. | 79 |
| Figure 3.4-1 As-built BIM of the main vault of Masegra Castle with method (a)(Banfi et al., 2017) | 83 |
| Figure 3.5-1 Example of attributes/parameters for green building properties. Source: (GSA-U.S. General Services Administration, 2007). | 88 |
| Figure 3.6-1 Example of Canny detection application, with two thresholds and hysteresis (Source: Canny, 1986). | 93 |
| Figure 3.6-2 Example of Sobel detection application. Source: (Dhule et al., 2016). .. | 93 |
| Figure 3.6-3 Discrete approximation to Gaussian function. | 94 |
| Figure 3.6-4 A couple of 3X3 Sobel convolution masks. Source: (Gupta and Ghosh Mazumdar, 2012). | 95 |
| Figure 3.6-5 The Sobel mask: the pixel and its eight neighbours. | 96 |
| Figure 3.6-6 Application of 2D convex hull on a set of points. Source: (Gärtner and Hoffman, 2013). | 97 |

| | |
|--|-----|
| <i>Figure 3.6-7 Forward chaining. Source: (Grosan et al., 2011).</i> | 99 |
| <i>Figure 3.6-8 Backward chaining diagram. Source: (Grosan et al., 2011).</i> | 100 |
| Figure 4.2-1 Process Mapping Symbols for BIM Process Maps. Source: (Messner et al., 2011). | 113 |
| Figure 4.2-2 - Business Process Map Notation for refurbishment. | 114 |
| Figure 4.3-1 Masseria Macchia Trappeto: aerial photo. Source: (Modugno et al., 2016). | 116 |
| Figure 4.3-2 Masseria Macchia Trappeto: Acquisition plane. Source: (Modugno et al., 2016). | 117 |
| Figure 4.3-3 Masseria Macchia Trappeto: Sparse Point Clouds. Source: (Modugno et al., 2016). | 118 |
| Figure 4.3-4 Masseria Macchia Trappeto. The entire 3D photo-reconstructed model. Source: (Modugno et al., 2016). | 119 |
| Figure 4.3-5 Masseria Macchia Trappeto. Adaptive surface for barrel vault modelling. Source: (Modugno et al., 2016). | 120 |
| Figure 4.3-6 Masseria Macchia Trappeto. Barrel vault modelling. Source: (Modugno et al., 2016). | 120 |
| Figure 4.3-7 Masseria Macchia Trappeto. Parametric modelling of openings and niches. Source: (Modugno et al., 2016). | 121 |
| Figure 4.3-8 Masseria Macchia Trappeto. Axonometric cross-section. Source: (Modugno et al., 2016). | 122 |
| Figure 4.3-9 Irregular mirror vault in Masseria Don Cataldo (IT_S_2) and Palazzo Palmieri (IT_S_5). | 122 |
| Figure-4.4-1 (a) Mirror vault on four sides (b) Octagonal mirror vault. Source: author. | 124 |
| Figure 4.4-2 - Acquisition plan. Source: (Di Lorenzo, 2015). | 125 |
| Figure 4.4-3 3D photo-reconstruction in Autodesk Remake. Source: author. | 126 |
| Figure 4.4-4 3D photo-reconstruction in Agisoft Photoscan. Source: author. | 127 |
| Figure 4.4-5 3D photo-reconstruction in Autodesk ReCap. Source: author. | 127 |
| Figure 4.4-6 3D mapping according to the vector direction. Source: author. | 127 |
| Figure 4.4-7- Graphical explanation of parameters of deviation evaluation. Source (FARO, 2018). | 130 |
| Figure 4.5-1 Masseria Macchia Trappeto: Decay mapping and semantic enrichment. | 131 |
| Figure 4.5-2 Masseria Macchia Trappeto: Decay mapping in 2D views extracted from 3D model. | 131 |
| Figure 4.5-3 Mesh segmentation, conversion in NURBS and generation of related BIM object. | 132 |

| | |
|--|-----|
| Figure 4.5-4 Masseria Macchia Trappeto: Scheduling of interesting attributes related to decay and building pathologies. | 133 |
| Figure 4.5-5 Segmentation of the mesh. | 133 |
| Figure 4.5-6 Decay mapping via extracted edges in 2D views. | 134 |
| Figure 4.5-7 S. Agostino Monastery: transformation over time and constructive-macro elements. | 135 |
| Figure 4.5-8 Integrated BIM database. Source: (Musicco, 2017). | 140 |
| Figure 4.5-9 Selection of categories, property to be analysed, query and property value of the tree units. Down the cracking pattern of three rooms of the building, two on the ground floor (a)Unit 1 and (b)Unit 2, and one on the first floor (c)Unit 3. | 141 |
| Figure 4.5-10 Test 1 Sobel-Sobel filters: Dynamo algorithm. Source: author. | 142 |
| Figure 4.5-11 Test 2 Canny-Sobel filters: Dynamo algorithm. Source: author. | 143 |
| Figure 4.5-12 Test 1 run with Sobel-Sobel filters: step 1 Sobel. Source: author. | 144 |
| Figure 4.5-13 Test 1 run with Sobel-Sobel filters: step 2 Sobel. Source: author. | 144 |
| Figure 4.5-14 Test 2 run with Canny-Sobel filters: step 1 Canny. Source: author. | 145 |
| Figure 4.5-15 Test 2 run with Canny-Sobel filters: step 2 Sobel. Source: author. | 145 |
| Figure 4.5-16 Crack detected and overlapping on the original image. Source: author. | 146 |
| Figure 4.6-1 Acquisition profiles in a BIM object and radargram L1AA. | 148 |
| Figure 4.6-2 Acquisition profiles as BIM object and radargram L1AB about vault ... | 148 |
| Figure 4.6-3 Photogrammetric model and merged thermal images. Source: (Di Lorenzo, 2015). | 149 |
| Figure 4.6-4 Insertion of quantitative data, derived from diagnostic tests, into the BIM wall. Source: author. | 150 |
| Figure 4.6-5 Diagnostic report. Source: author. | 152 |
| Figure 4.6-6 Vault and eighteenth-century wooden slab on the noble floor. | 154 |
| Figure 4.6-7 Response type of radar survey on wooden slabs. | 155 |
| Figure 4.6-8 Thermography of a vault. | 155 |
| Figure 4.6-9 BIM model, front elevation, noble floor and third floor. | 156 |
| Figure 4.6-10 Management and sharing methods of attributes with BIM. | 157 |
| Figure 4.7-1 Picture of crack patterns of the southern wall. | 158 |
| Figure 4.7-2 Masseria Don Cataldo: BIM model. Source: author. | 159 |
| Figure 4.7-3 Scheme about correlations: symptoms, surveys, actual causes and interventions. Source: author. | 161 |
| Figure 4.7-4 Inferential tree. Source: author. | 163 |
| Figure 4.7-5 BIM object about crack pattern and automatic updating of parameters. Source: author. | 166 |

Figure 4.7-6 Algorithm for inference logics: prediagnosis, diagnosis and interventions about buckling in a masonry wall. Source: author. 166

Figure 4.8-1 Enter page of the HBIM portal for uploading models and files. 168

Figure 4.8-2 The reports viewer displays physical measurements, visual surveys, historic information, and analysis results. 169

Figure 4.8-3 The property categories: Historical significance, Transformation over time, Interpretation, and Preservation. 170

Figure 4.8-4 Display of point clouds and metadata about the acquisition procedures. 171

Figure 4.8-5 Use of mark-up for the insertion of annotations, comments and the attachment of information in specific location. 171

Figure 4.8-6 Thermal imaging reports. 172

Figure 4.8-7 State manager and mark-ups of decay phenomena. 172

Figure 4.8-8 Real-time monitoring of environmental parameters. 173

Figure 5.2-1 Masseria Macchia Trappeto: URL for Virtual Reality in Autodesk 360. Source: (Modugno et al., 2016). 176

Figure 5.2-2 S.Agostino Monastery: scaffoldings. 177

Figure 5.3-1 Schedule for estimation of intervention costs. 183

Figure 5.4-1 Comparison between original ortho-image and Canny-Sobel processed image. Source: author. 185

Figure 5.7-1 Real-time analysis of CO2 levels and early-warnings measures to be adopted. 190

Figure 5.7-2 TH2_VH_FLO_LR and TH3_VH_FLO_LR (2016). Source: CABER, University of West England. 195

Figure 5.7-3 TH8_VH_FL1_BT and TH9_VH_FL1_BT (2016). Source: CABER, University of West England. 196

LIST OF TABLES

| | |
|--|-----|
| Table 2.2-1 Distribution of papers reviewed. Source: author..... | 37 |
| Table 2.4-1 Trend in parametric modelling from acquired point clouds in HBIM methodology. Source: author..... | 44 |
| Table 2.4-2 Analysis of literature on energy retrofitting and methods of thermal data/information capture for existing buildings, HBIM and other applications. Source: author..... | 54 |
| Table 2.4-3 BIM model and external databases as tools for energy simulation applications. Source: author..... | 59 |
| Table 2.4-4 Management of diagnostic tests and monitoring within BIM approach. Source: author..... | 62 |
| Table 2.4-5 Case studies carried out connecting BIM tools and external database for monitoring infrastructure. Source: (Bruno et. al, 2018)..... | 65 |
| Table 3.4-1 Level of Accuracy (USIBD, 2016)..... | 84 |
| Table 3.5-1 Template for recording diagnostic tests attributes in BIM object. Source: author..... | 89 |
| Table 3.6-1 Sources of uncertainties. Source: (Grosan et al., 2011)..... | 102 |
| Table 4.1-1 Case studies in South Italy..... | 108 |
| Table 4.1-2 Case studies in United Kingdom..... | 110 |
| Table 4.4-1 Typical representation scales in Cultural Heritage field and accuracy. Source: (USIBD, 2016)..... | 128 |
| Table 4.4-2 Five defined Levels of Accuracy. Source: (USIBD, 2016)..... | 129 |
| Table 4.5-1 Parameters about technical properties of constructive macro-components..... | 137 |
| Table 4.5-2 Parameters about previous interventions..... | 137 |
| Table 4.5-3 Parameters about crack patterns description..... | 138 |
| Table 4.7-1 Description about objectives of surveys and tests. Source: author..... | 162 |
| Table 4.7-2 Shared parameters about symptoms, surveys, actual causes and interventions. Source: author..... | 165 |

Table 5.2-1 Comparison between ground resolution values and architectural scale for indoor environments. 176

Table 5.2-2 Calculation of percentage of points with $\epsilon < 30$ mm..... 180

Table 5.7-1 Psychrometric formulae. 193

ACRONYMS

| | |
|----------|--|
| AEC | Architecture, Engineering and Construction |
| AI | Artificial Intelligence |
| AIA | American Institute of Architects |
| API | Application Programming Interface |
| AR | Augmented Reality |
| BACnet | Building Automation and Control networks |
| BAS/BA | Building Automation System |
| BCVTB | Building Control Virtual Test Bed |
| BEMS/BEM | Building Energy Management Systems |
| BHIMM | Built Heritage Information Modelling and Management |
| BIM | Building Information Modelling |
| BMS | Building management System |
| BrIM | Bridge Information Modelling |
| BT | breakage-triggered |
| CAD | Computer Aided-Design |
| CH | Cultural Heritage |
| CHIM | Cultural Heritage Information Management |
| CMMS | Computerised Maintenance Management System |
| COBie | Construction Operations Building information exchange |
| CPS | Cyber Physical Systems |
| DA-HBIMM | Diagnosis-Aided Historic Building Information Modelling and Management |
| DB | DataBase |
| DBMS | DataBase Management System |
| EDMS | Electronic Document Management System |
| EPS | Expanded polystyrene |
| FDD | Fault Diagnostic and Detection |
| FEM | Finite Elements Model |
| FM | Facility Management |

| | |
|------------------|--|
| GBI | Green Building Index |
| gbXML | Green Building extensible mark-up language |
| GPR | Ground Penetrating Radar |
| GPS | Global Positioning System |
| HBIM 1/H-BIM | Historic Building Information Modelling |
| HBIM 2 | Heritage Building Information Modelling |
| HBIMM | Historic Building Information Modelling and Management |
| HBRP | Housing Building Refurbishment Plan |
| HVAC | Heating, Ventilation and Air Conditioning |
| ICP | Iterative Closest Point |
| ICT | Information & Communication Technologies |
| IE | Information Exchange |
| IFC | Industry Foundation classes |
| IoT | Internet of Things |
| IR | Information Requirements |
| LCA | Life Cycle Assessment |
| LEED | Leadership in Energy and Environmental Design |
| LiDAR | Light Detection and Ranging |
| LoD | Level of Detail |
| LOD | Level Of Development |
| LVDT | Linear Variable Displacement Transducer |
| MCDM | Multiple Criteria Decision Making |
| mesh-OBIM | mesh to BIM objects |
| MVD | Model View Definition |
| NoSQL | Not Only SQL |
| NURBS | non-Uniform Rational Basis-Spline |
| ODBC | Open Database Connectivity |
| pointclouds-OBIM | point clouds to BIM objects |
| RANSAC | RANdom SAMple Consensus |
| RFID | Radio Frequency Identification |
| RGB-D sensors | RGB colours and Depth sensors |
| RPVs | Remotely Piloted Vehicles |

SCADA

SfM

SHM

SOA

SQL

TMH

UAVs

VR

WSN

XML

Supervisory Control and Data Acquisition

Structure for Motion

Structural Health Monitoring

service-oriented architecture

Structured Query Language

Traditional Malay House

Unmanned Aerial Vehicles

Virtual Reality

Wireless Sensors Networks

Extensible Markup Language

CURRICULUM VITAE



PHD CANDIDATE
POLYTECHNIC UNIVERSITY OF BARI

PERSONAL INFORMATION

| | |
|---------------|---|
| Name | BRUNO SILVANA BUILDING ENGINEER AND ARCHITECT |
| Address | Via Giuseppina e Biagia Ferri, 19 - 70037, Ruvo di Puglia (Bari), Italy |
| Phone | +39 3337811526 |
| E-mail | silvana.bruno@poliba.it bruno_silvana_89@libero.it |
| Nationality | Italian |
| Date of birth | 29/04/1989 |

EDUCATION AND TRAINING

| | |
|------------------------------|---|
| November 1015 – October 2018 | Ph.D Student of Polytechnic University of Bari in “Risk and environmental, territorial and building development”, Department of Civil, Environmental, Land, Building Engineering and Chemics (DICATECh) Research named: “The implementation of automatic diagnostics and monitoring towards Diagnosis-Aided Historic Building Information Modelling and Management” Tutors: Prof. Fabio Fatiguso Prof. Guido Raffaele Dell’Osso Prof. Lamine Mahdjoubi |
| 18/01/2015 | Admitted to the engineers register of Bari - Section A |
| 26/09/2014-21/09/2015 | Master in European Construction Engineering, Universidad de Cantabria ,Santander, Spain (8,6/10) |
| 09/2008-29/04/2014 | Master Degree in Building Engineering and Architecture (Ingegneria Edile-Architettura, five years, unique cycle) (average subjects mark=29,6/30) (final mark 110/110 magna cum laude) Polytechnic University of Bari, Bari (Italy) Dissertation entitled: “COMPARISON OF METHODS FOR DYNAMIC IDENTIFICATION AND NONDESTRUCTIVE TESTING FOR THE EVALUATION OF NUMERICAL MODELING EFFECTIVENESS OF MASONRY BUILDINGS: the case of bell towers” Tutors: Prof. Fabio Fatiguso, Prof. Carlo Giuseppe Marano, Co-Tutor: Ing. Domenico Colapietro |

INTERNATIONAL EXPERIENCES

- 10/09/2018 - 11/09/2018 Organizer, member of the scientific committee and speaker of the International Conference Heritage BIM, Bath, UK, organized by Prof. Lamine Mahdjoubi, University of West England
- 13/10/2017 - 16/04/2018 PhD visiting period at Centre for Architecture and Built Environment Research (CABER) (University of West England, Bristol, UK)
Collaboration in developing the architecture of HBIM platform, within the HBIM project with **Prof. Lamine Mahdjoubi** and **Ammar Alzaatreh**
<http://alpha.hbim.org/>
- Collaboration in the research project to assess the risk of condensation and mould growth in a English historic cottage, belonging to the **National Trust**, with **Prof. Lamine Mahdjoubi**, **Prof. Bill Gething**, **Ammar Alzaatreh**, **Samantha Organ**
- 10/05/2017-12/05/2017 2nd International Conference on Building Information Modelling (BIM) in Design, Construction and Operations, Alicante, Spain

ACADEMIC ACTIVITIES

Teaching support (Politecnico di Bari)

Teaching support of the courses "*Historical building rehabilitation + maintenance and conservation of the existing building stock*", Prof. F. Fatiguso", and "*Construction Management*", Prof. Dell'Osso.

Co-tutoring of Master Thesis (Politecnico di Bari)

[1] "BIM implementation in maintenance activities" - Gabriella di Blasio

Relatori Prof. F. Fatiguso, Prof. J. Diaz

[2]"Integration of building diagnostics in BIM for existing buildings" – Anna Di Lorenzo

Relatori Prof. F. Fatiguso, Correlatori: Riccardo Tavolare, Prof. C. Verdoscia

[3] "Geometric and decay survey of built heritage in BIM" - Domenico Modugno

Relatore Prof. G.R.Dell'Osso

[3] "Potentiality of BIM approach in refurbishing existing building for contractors - case study

Calò Carducci Palace in Bari" – Noemi Pepe

Relatori Prof. G.R.Dell'Osso, Correlatori: Riccardo Tavolare

[4]"HBIM and automatic assessment of reinforced concrete. Kursaal Theatre of Bari" - Enrico Relvini

Relatore Prof. G.R.Dell'Osso

[4] "BIM methodology and survey for traditional architectures" - Giacomo Sorino

Relatore Prof. G.R.Dell'Osso

[5] "4D – HBIM for knowledge management and qualification of historic buildings. Convento S. Agostino, Trani" – Antonella Musicco

Relatori Prof. G.R.Dell'Osso, Prof. Fabio Fatiguso

WORK EXPERIENCE

20/09/2015- 10/11/2015

Internship in an Engineering and Architecture studio as engineer

Association of Engineers and Architects "Studio Affatato-Fatelli", via 1° Maggio 3/B
70037 - Ruvo di Puglia, Bari, Italy - Tel. +39 080 3615871 | PIVA 06295730722
Activity: refurbishment and new construction of building dwellings.

15/06/2014-10/09/2014

Internship in Restoration company

Eng. S. Caputi Iambrenghi, Eng. P. Ciamarrusti, Eng. L. Nigro,
Corso Sidney Sonnino, 8, 70121 Bari (Italy)

<http://www.studiocnc.it/index.php/progetti/edifici-monumentali/edifici-monumentali-castello-copertino>

Engineering and structural project for refurbishment and restoration of Cultural Heritage
Diagnostics and intervention design of Copertino Castle (Lecce, Italy)

PUBLICATIONS

Bruno, S., Dell'Osso, G.R., Fatiguso, F., Musicco, A. (2018) "The role of 4D Historic Building Information Modelling and Management in the analysis of the constructive evolution and decay condition within the refurbishment process", International Journal of Architectural Heritage (Under review)

Bruno, S. (2018) Modellazione informativa del patrimonio storico verso l'automatizzazione della diagnosi (DA-HBIMM), Proceedings of Colloqui.AT.e 2018, Ar.Tec Conference, Cagliari, Italy.

Bruno, S., De Fino, M., Fatiguso, F. (2018) "Historic Building Information Modelling: performance assessment for diagnosis-aided information modelling and management, Automation in Construction, 86, pp. 256-276. <https://doi.org/10.1016/j.autcon.2017.11.009>

Bruno, S., Fatiguso, F. (2018) "Building Conditions Assessment of built heritage in Historic Building Information Modelling", International Journal of Sustainable Development and Planning, selected paper of BIM 2017, WIT Conference, Alicante (Spain). DOI: 10.2495/SDP-V13-N1-36-48

Bruno, S. (2017) "Diagnostic Information Management in Historic Building Information Modeling for the Built Heritage", Proceedings of Colloqui.AT.e 2017, Ar.Tec Conference, Ancona, Italy.

Bruno, S., Dell'Osso G. R., Fatiguso, F., Modugno, D. (2017) "Quality control of refurbishment project with Building Information Modeling", ISTeA 2017, Re-shaping the construction industry, Florence, Italy

Bruno, S., De Fino, M., & Fatiguso, F. (2017) "Historic Building Information Modeling towards building diagnostic data management. A case study" TEMA, Ar.Tec. Journal, selected paper of Colloqui.AT.e 2016. <https://doi.org/10.17410/tema.v3i2.146>

Bruno, S., De Fino, M., & Fatiguso, F. (2016) "BIM-aided refurbishment process of Cultural Heritage." ISTeA-BACK TO 4.0 Rethinking Digital Construction Industry," Maggioli Editore, pp. 60-69

Bruno, S., (2016) "HBIM approach for built heritage refurbishment" Proceedings of Colloqui.AT.e 2016, Ar.Tec Conference, Matera, Gangemi Editore

Updating at: https://www.researchgate.net/profile/Silvana_Bruno

CONFERENCES

International Conference Heritage BIM, Bath 10-11 settembre 2018
Speaker about the presentation "Artificial Intelligence for Damage Diagnosis Within Historic Building Information Modelling and Management"
<https://conference.hbim.org/>

Colloqui.AT.e 2017 Demolition or reconstruction? - Ar.Tec 28-29 September 2017
Ancona, Italy

ISTeA 2017 Re-shaping the Construction Industry 14 e 15 Settembre 2017, Florence, Italy

BIM 2107, WIT Conference – 9 may/13 may 2017, Alicante (Spain)
Invited paper (speaker) "Building Assessment Conditions of built heritage in Historic Building Information Modelling"

Colloqui.AT.e 2016"- 13 october 2016 (Matera, Italy)
Presented work (speaker) "BIM-aided refurbishment process of Cultural Heritage"

ISTeA 2016 - ISTeA-BACK TO 4.0 Rethinking Digital Construction Industry 30 june/1 july 2016
Presented work (speaker) "BIM-aided refurbishment process of Cultural Heritage"

PH.D COURSES/SEMINARIES

Participation at Ph.D. courses:

- Research in building process management (Prof. Bruno Daniotti, Politecnic University of Milano)
- Rehabilitation and restoration of masonry structures (Prof. Gianvittorio Rizzano, Università di Salerno)
- Innovative techniques of intervention for seismic retrofitting of existing structures (Prof. Roberto Realfonzo, Università di Salerno)
- Seismic analysis and vulnerability assessment of R.C. existing buildings (Prof. Ing. Enzo Martinelli, Università di Salerno)

Participation at Ph.D. seminars:

- 3D Modeling & BIM APPLICAZIONI E POSSIBILI FUTURI SVILUPPI, Università La Sapienza, Roma, Italy 20-22 april 2016
- Modellazione e gestione delle informazioni per il patrimonio edilizio esistente - Built Heritage Information Modelling/Management – BHIMM, Polytechnic University of Milano, Italy 21/22 june 2016
- Il Politecnico di Bari per il BIM, 12 october 2016, Polytechnic University of Bari, Italy (speaker)
- Il Politecnico di Bari per il BIM, 13 november 2016, Università della Basilicata – Matera (Italy) (speaker)
- The language of the structures, the Italian engineering school - Prof. Sergio Poretti (Università di Roma – Tor Vergata) Prof.ssa Tullia Iori (Università di Roma – Tor Vergata)
- Dynamic response of masonry elements stressed out of the plane (Ing. Corrado Chisari, Università di Salerno)
- Analysis of ordinary masonry buildings - elastic solutions for masonry panels and walls subjected to in-plane stress (Ing. Antonio Fortunato, Università di Salerno)
- Influence of different types of intervention in the analysis of a masonry building with equivalent frame model (Ing. Massimo Latour, Università di Salerno)
- Structural behaviour of masonry buildings subject to horizontal actions and examples of seismic improvement (Prof. Rosario Montuori Università di Salerno)

PERSONAL SKILLS

MOTHER TONGUE ITALIAN

OTHER LANGUAGE **ENGLISH – B2 - ATTENDANT OF IELTS COURSE – LORD BYRON BARI**
• Reading GOOD
• Writing GOOD
• Speaking GOOD

OTHER LANGUAGE **SPANISH**
• Reading ELEMENTARY
• Writing ELEMENTARY
• Speaking ELEMENTARY

OTHER LANGUAGE **GERMAN – A1 – ATTENDANT OF COURSE FOR A1 CERTIFICATION AT JUSTUS LIEBIG UNIVERSITY
GIESSEN, GERMANY**
• Reading ELEMENTARY
• Writing ELEMENTARY
• Speaking ELEMENTARY

Signature

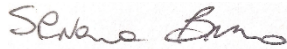

Bari, 19/12/2018