



Politecnico
di Bari

Repository Istituzionale dei Prodotti della Ricerca del Politecnico di Bari

Thermoeconomic optimisation of small-scale organic Rankine cycle systems based on screw vs. piston expander maps in waste heat recovery applications

This is a pre-print of the following article

Original Citation:

Thermoeconomic optimisation of small-scale organic Rankine cycle systems based on screw vs. piston expander maps in waste heat recovery applications / Pantaleo, A. M.; Simpson, M.; Rotolo, G.; Distaso, E.; Oyewunmi, O. A.; Sapin, P.; De Palma, P.; Markides, C. N.. - In: ENERGY CONVERSION AND MANAGEMENT. - ISSN 0196-8904. - STAMPA. - 200:(2019). [10.1016/j.enconman.2019.112053]

Availability:

This version is available at <http://hdl.handle.net/11589/207052> since: 2021-03-12

Published version

DOI:10.1016/j.enconman.2019.112053

Publisher:

Terms of use:

(Article begins on next page)

Thermoeconomic optimisation of small-scale organic Rankine cycle systems based on screw vs. piston expander maps in waste heat recovery applications

A. M. Pantaleo^{a,b,*}, M. Simpson^a, G. Rotolo^c, E. Distaso^c, O. A. Oyewunmi^a, P. Sapin^a,
P. De Palma^c, C. N. Markides^a

^a Clean Energy Processes (CEP) Laboratory, Department of Chemical Engineering, Imperial College London,
South Kensington Campus, London SW7 2AZ, UK

^b Department of Agro-environmental Sciences, University of Bari,
Via Amendola 165/A, 70125 Bari, Italy

^c Department of Mechanics, Mathematics and Management, Polytechnic of Bari,
Via Re David 200, 70125 Bari, Italy

Abstract

The high investment cost of organic Rankine cycle (ORC) systems is a key barrier to their implementation in waste heat recovery (WHR) applications. In this work, numerical simulations and optimisation strategies are used to study the performance and profitability of small-scale ORC systems using either reciprocating-piston or single/dual stage screw expanders, when recovering heat from the exhaust gases of a 185-kW natural-gas reciprocating internal combustion engine (ICE), and leading to a power generated by the ORC system in the range of 10 – 20 kW. For the piston expander, a lumped-mass model and an optimisation approach based on artificial neural networks are used to generate full performance maps over a wide range of flow rates and pressure ratios. For the screw expanders, performance and cost correlations from the literature are used. The thermodynamic analysis shows that for most of the working fluids here analysed, two-stage screw expanders deliver more power than either single-stage screw or piston expanders due to the higher conversion efficiency at the required pressure ratios. The best fluids are acetone and ethanol, as these provide a compromise between the exergy losses in the condenser and in the evaporator. The maximum net power output is found to be 17.7 kW, from an ORC engine operating with acetone and a two-stage screw expander. The thermoeconomic optimisation shows that, for most of the fluids, reciprocating-piston expanders show a potential for lower specific costs. The minimum specific investment cost of 1630 €/kW is observed for an ORC engine with a piston expander, again with acetone as the working fluid. This system, optimised for minimum cost, also gives the shortest payback time of 4 years at an avoided electricity cost of 0.13 €/kWh. Finally, financial appraisals show a high sensitivity of the investment profitability to the value of produced electricity and heat-demand intensity.

© 2019 The Authors. Published by Elsevier Ltd.

A short version of this paper was presented at the 4th Annual Engine ORC Consortium (EORCC) Workshop for the Automotive and Stationary Industries (15-17 November 2017, Detroit). This manuscript is a substantial extension of the short version of the conference paper.

Keywords: combined heat and power, CHP, expanders, organic Rankine cycle, ORC, reciprocating-piston expander, screw expander, waste heat recovery, WHR

* Corresponding author. Tel.: +39 (0)80 5442869; Fax: +39 (0)80 5442830
E-mail: antonio.pantaleo@uniba.it; a.pantaleo@imperial.ac.uk

45 **Nomenclature**

46

47 **Latin characters**

48

49 *A* area [m²]

50 *C* cost [€]

51 *c_p* specific heat capacity [J.kg⁻¹.K⁻¹]

52 *D* diameter [m]

53 *d_{SH}* non-dimensional superheat [-]

54 *H* pump head [m]

55 *h* heat transfer coefficient [W.m⁻².K⁻¹]

56 *I* exergy destruction rate [W]

57 *k* thermal conductivity [W.m⁻¹.K⁻¹]

58 *M* molar mass [kg/kmol]

59 *m* mass [kg]

60 *ṁ* mass flow rate [kg.s⁻¹]

61 *Nu* Nusselt number [-]

62 *p* pressure [Pa]

63 *Pr* Prandtl number [-]

64 *q* vapour quality [-]

65 *Q̇* heat flow rate [W]

66 *Re* Reynolds number [-]

67 *T* temperature [K]

68 *U* overall heat transfer coefficient [W.m⁻².K⁻¹]

69 *V̇* volume flow rate [m³.s⁻¹]

70 *V_r* volume ratio [-]

71 *Ẇ* power [W]

72 *x* liquid-phase mass fraction [-]

73 *Ẋ* exergy flow rate [W]

74 *X_{tt}* Lockhart-Martinelli parameter [-]

75 *y* vapour-phase mass fraction [-]

76

77 **Greek characters**

78

79 ΔT temperature difference [K]

80 η efficiency [-]

81 μ dynamic viscosity [Pa.s]

82 ρ density [kg.m⁻³]

83

84 **Subscripts**

85

86 0 reference state

87 1,2,3,4 working fluid states in the ORC

88 cond condenser

89 cs cooling stream

90 evap evaporator

91 ex exergy

92 exh exhaust gas

93 exp expander

94	fl	flux
95	hs	heat source
96	i	index
97	in	inlet
98	ip	inner pipe
99	is	isentropic
100	l	liquid
101	lm	logarithmic mean
102	max	maximum
103	min	minimum
104	op	outer pipe
105	out	outlet
106	pis	piston
107	pump	pump
108	pp	pinch point
109	r	ratio
110	s	specific
111	scr	screw
112	sh	superheat
113	sp	single phase
114	tot	total
115	tp	two phase
116	v	vapour
117	w	jacket water
118	wf	working fluid

119
120 **Abbreviations**

121		
122	CAMD	computer-aided molecular design
123	CEPCI	chemical engineering plant cost index
124	CHP	combined heat and power
125	DPI	direct permanent investment
126	GWP	global warming potential
127	ICE	internal combustion engine
128	IRR	internal rate of return
129	LCOE	levelised cost of energy
130	LHV	lower heating value
131	MGT	micro gas-turbine
132	NG	natural gas
133	NPV	net present value
134	ODP	ozone depletion potential
135	ORC	organic Rankine cycle
136	PBT	payback time
137	PM	particulate matter
138	SAFT	statistical associating fluid theory
139	TES	thermal energy storage
140	VOCs	volatile organic compounds
141	WHR	waste-heat recovery
142		

143 1. Introduction

144

145 Recent years have seen an increasing interest in the utilisation of renewable energy resources and
146 in improving the energy efficiency of energy systems [1]. In this scenario, the use of the organic
147 Rankine cycle (ORC) technology has attracted attention thanks to its suitability for converting low-
148 temperature heat to power [2]. After a couple of decades, starting from the 1980s, during which
149 ORC systems were mainly employed in geothermal applications, this technology has experienced
150 significant growth, with an average annual installed capacity between 75 MW and 200 MW,
151 reaching an installed capacity of ~350 MW in 2015. By the beginning of 2017, ORC technology
152 had a total installed capacity close to 3 GW, distributed over 1750 systems [3].

153

154 Geothermal power is an important sector for ORC technology, in particular in relation to large
155 scale plants, reaching a share of almost 75% of all installed ORC system capacity in 2009,
156 concentrated in a relatively small number of systems (less than 350). Biomass ORC applications
157 represented 12% of all installed capacity at the start of 2017 [3], with many of these being medium-
158 to small-scale systems. Some solutions include the hybridisation of biomass cycles with the
159 combined use of natural gas, in order to achieve higher conversion efficiencies and overcome issues
160 of seasonality and logistics of biomass supply [4–8]. Solar applications are not competitive so far,
161 due to the high investment cost of the solar collectors, which make the whole ORC systems more
162 expensive than photovoltaic panels with electricity storage. However, hybrid solutions such as
163 concentrating solar/biomass systems with ORC combined cycles have been proposed recently at
164 research and pre-commercial scales [9,10].

165

166 Waste heat recovery (WHR) via ORC systems is a more recent market, which is particularly
167 promising to increase the efficiency of energy conversion systems and reduce pollution emissions
168 at large scale [11–13]. Several major companies are active in this market, with large- and medium-
169 scale systems recovering heat mainly from gas turbines, internal combustion engines (ICEs) or
170 industrial processes. WHR applications accounted for almost 15% of the total ORC market in 2017,
171 with a relevant number of small-size (< 4 kW) systems in operation [3], representing a secondary
172 market for ORC systems and experiencing a fast growth over the last years. Multiple industrial
173 processes may benefit from such WHR technologies. Despite their apparently large heat recovery
174 potential, cement and lime or glass industries account for only a small share of the heat recovery
175 market. Landfill and biogas engines are the focus of many ORC manufacturers that offer small units
176 (up to 200 kW), thanks to incentives in different countries [14]. A number of recent studies have
177 focused on the optimisation of ORC systems for small-scale WHR technologies. In particular, an
178 optimisation framework to maximise power and minimise fuel consumption of an integrated ICE
179 with bottoming ORC engine was proposed by Chatzopoulou and Markides [15], reporting a total
180 power output increase of 30% in comparison to nominal system design, due to the modulation of
181 exhaust gas temperature to increase the ORC system performance.

182

183 The capital cost of an ORC system is a crucial deciding factor in the implementation of this WHR
184 technology. Manufacturers offer ORC solutions in a broad range of power outputs and temperature
185 levels for different applications. In this work, cost data is presented from a number of companies
186 and summarised in Figure 1 as a function of the power output. The scatter of the data is due to
187 different integration costs and pricing strategies for each manufacturer. Thus, while specific costs
188 should not be generalised, the results serve to illustrate the general trend.

189

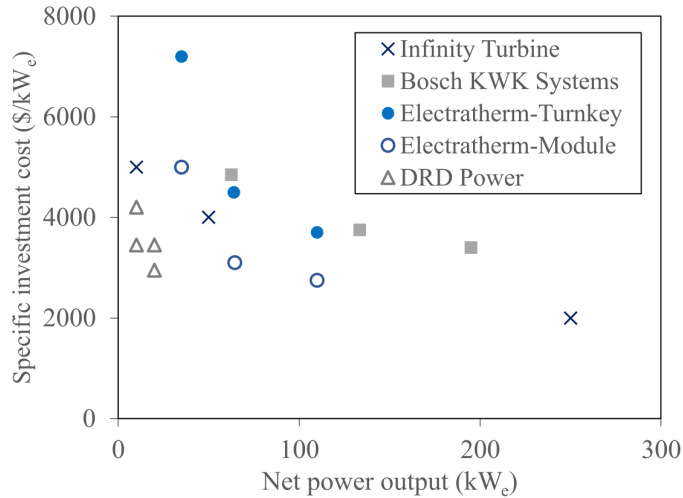

190
191

192
193
194

Figure 1: Specific costs of several ORC systems as a function of power output (authors’ interpretation of manufacturer data).

195
196
197
198
199

As expected, the specific cost decreases when the power output increases. However, Figure 1 reports the “turnkey costs” (except for Electratherm), that are hence not limited to the module costs (sum of the unitary component costs) but include engineering, procurement, installation and insurance. The costs are aligned to those obtained from the proposed cost assessment methodology.

200
201
202
203
204
205
206
207
208
209
210
211
212
213
214
215
216
217
218
219
220
221
222
223
224
225

One of the most critical components of a cost-effective ORC system for WHR is the expansion device. In general, since the typical power output is in the small-medium range (5 – 300 kW_e), volumetric expanders are preferred to turbines [16]. Their isentropic efficiency mainly depends on valve pressure losses, friction, mass-leakage, and thermal losses, which are themselves influenced by the expander operating conditions. In particular, the pressure ratio imposed on the expander is the main parameter influencing its performance. Positive-displacement expanders have a built-in volume ratio (usually in the range 2 – 7), which is linked to the design pressure ratio by the fluid thermodynamic properties. In theory, the optimal design pressure ratio should match the system pressure ratio – defined as the ratio between the ORC evaporating and condensing pressures. However, for a given volumetric expansion machine, the maximum power output can be achieved in under-expansion or over-expansion working conditions due to the influence of the other loss mechanisms [17,18]. The selection criteria for the expanders for ORC-based micro-CHP systems are discussed by Qiu et al. [19], proposing an assessment of the market trends of turbine, screw, scroll and vane expanders, and concluding that scroll and vane expanders are likely to be the best candidates for ORC-based micro-CHP systems within the capacity range of 1 – 10 kW_e. A review of working fluids and expanders for ORC systems is also available from Bao and Zhao [20], together with the assessment of key parameters for expander selection, such as the isentropic efficiency, pressure ratio, power output, lubrication, rotational speed, dynamic balance, reliability, cost, working temperatures and pressures, leakage flows, noise and safety. The paper provides an up-to-date assessment of prototypes of various types of expansion machines. Other researchers [21,22] review similar expander technologies for small-scale applications, recognising that there are several gaps in the optimisation of expansion machines, and that micro-scale expanders suitable for ORC systems are not yet commercially available. Song et al. [23] discuss the performance of scroll expanders and the main technical limitations for ORC applications, assessing the related simulation and optimisation methods.

226 Scroll and rotary expanders have been shown to be suitable for small sizes, i.e., below 10 kW, with
227 typical built-in volume ratios below 5. In the medium power output range, i.e., 10 – 300 kW, screw-
228 type expanders are considered the most suitable positive-displacement devices. Two types of screw
229 expanders are usually employed: single-screw expanders and twin-screw expanders. The latter are
230 found to be more cost-effective for power production [24], while recent studies that focused on single-
231 screw expanders for WHR applications demonstrated that they can achieve isentropic efficiency
232 above 70% [24]. At intermediate power output scales (~10 – 100 kW), reciprocating-piston machines
233 can be cost-competitive with respect to other positive-displacement machines. In particular, there is
234 a renewed interest in their use in small-scale steam and ORC systems [25].
235

236 The inherent advantages of reciprocating-piston expanders over other positive-displacement
237 machines are their ability to provide higher built-in volume ratios, and robust part-load performance.
238 Moreover, they can withstand high operating pressures and temperatures, and work at low rotational
239 speeds. However, pressure losses through the valves, gas-to-wall heat transfer, mass leakage and
240 friction may limit their efficiency. Therefore, pressure losses must be minimised with a careful valve
241 design and timing strategies, while effective lubrication is needed to limit friction losses. The
242 unsteady heat transfer between the gas and the cylinder walls, and the mass leakage of gas between
243 the piston and the cylinder, remain relatively challenging to predict and address. These issues are
244 currently a matter of investigation to enable the design of high-efficiency machines [26].
245

246 Another important area of research in ORC optimisation is the selection of the working fluid. Bao
247 and Zhao [20] provided an extensive review of fluids and their selection for ORC applications
248 according to thermodynamic performance indicators and environmental or safety aspects.
249 Oyewunmi et al. [27] proposed a specific optimisation of pure working fluids and mixtures of fluids
250 for ORC systems, demonstrating that: (i) the temperature glide during isobaric
251 evaporation/condensation of working fluid mixtures provides a better thermal match to the heat-
252 source/sink streams, thus improving overall performance; (ii) a whole system energy optimisation
253 should include the possibility to use the cogenerated heat from the ORC system condenser,
254 optimising the condensing temperature. White et al. [28,29] described the use of computer-aided
255 molecular design (CAMD) tools, based on statistical associating fluid theory (SAFT), for the
256 thermodynamic modelling and optimisation of ORC systems, together with heat-exchanger sizing
257 models, component cost correlations and thermoeconomic assessments. Both the ORC engine
258 components and working fluid are therefore optimised in a single step and over a wide range of
259 heat-source conditions.
260

261 Despite the wide literature on working-fluid selection for ORC systems in different applications,
262 little attention has been paid so far to the combined selection and optimisation of the expansion
263 machine and the working fluid, which is a specific focus of this paper. In particular, this work aims
264 at investigating the performance and profitability of ORC systems for heat recovery from ICEs,
265 which presents a global installed capacity of about 400 MW and 65% of the total installed ORC
266 capacity [3]. In such applications, the power generated by the ORC system lies in the range of 10
267 to 20 kW_e, where screw and piston expanders are promising candidates in terms of energy
268 performance and investment profitability. In particular, a single-stage screw expander, a two-stage
269 screw expander and a single-stage piston expander are here compared. Simulations are performed
270 for 18 suitable fluids, chosen on the basis of their low global warming potential, ozone depletion
271 potential, health hazard and instability hazard. Thermodynamic and thermoeconomic optimisations
272 of the ORC system are performed in order to find the optimal configurations for each fluid and
273 expander, comparing the performance of different technical solutions.
274

275 Finally, an economic feasibility study of the optimal ORC unit is proposed, using: (i) an analysis
276 of component costs; and (ii) cost data from manufacturers relating to installation, operation and
277 maintenance. The profitability of the investment is analysed through the metrics of net present
278 value and internal rate of return, exploring the sensitivity of the economic viability to key factors
279 such as the electricity price and onsite heat demand.

280
281 The proposed comparison of expanders and working fluids illustrates the key techno-economic
282 factors needed to facilitate the implementation of such technologies, assisting policymakers to set
283 up support measures and investors to select promising market segments. The results also provide
284 useful insights for manufacturers about the best working fluids, opportunities for improved
285 efficiency, and promising expansion devices.

286
287 The paper is organised as follows: Sections 2 and 3 provide details of the thermodynamic and cost
288 models used in this work, with working fluid selection discussed in Section 4. Section 5 describes
289 the thermodynamic and thermoeconomic optimisation and provides a discussion of related results.
290 The economic analysis is presented in Section 6. Finally, conclusions are drawn in Section 7.

291 292 **2. Thermodynamic model**

293 This section provides the characteristics of the considered internal combustion engine and the
294 details of the thermodynamic model employed to simulate the behaviour of the ORC system. In
295 particular, the models employed for the screw expander and for the piston expander are discussed.
296 Concerning the screw expanders, the performance map proposed by Astolfi [30] has been
297 employed, who correlated the optimal efficiency of a number of different screw expander designs
298 against volume ratio and volumetric flow rate, providing an estimate for possible full-load
299 performance at different operating points. For the piston expanders, a lumped-mass model of the
300 expander [31] and an optimisation algorithm based on artificial neural networks are used to
301 generate a full performance map over a wide range of mass flow rates and pressure ratios. The
302 performance data for the expanders are combined with the models of the heat exchangers and the
303 pump to develop an accurate thermodynamic model of the overall ORC system.

304 305 **2.1 ICE model**

306
307 The application considered in this work concerns the recovery of heat from the exhaust gases of a
308 185-kW_e natural-gas reciprocating ICE for stationary energy cogeneration. In particular, this work
309 is based on an ICE, which is a combined heat and power (CHP) unit supplied by company ENER-
310 G (now Centrica). The engine drives an alternator to produce electricity, while heat is recovered
311 from the exhaust, jacket water and oil cooling circuits. The technical data of the ICE considered in
312 this work are reported in Tables 2 and 3.

313
314 **Table 2:** Technical data of the ENER-G/Centrica E185 (low NO_x) natural gas ICE.

Number of cylinders	12	Compression ratio	12
Configuration	90° V	Working procedure	4-stroke
Displacement (L)	22	Engine rated speed (rpm)	1500

315
316 According to manufacturer data, the molar composition of the exhaust gases is: N₂ = 73.7%, O₂ =
317 12.9%, CO₂ = 8.9%, H₂O = 3%, Ar = 1.5%. The assumed backpressure is 1.1 bar. The exhaust
318 temperature of the engine is estimated by REFPROP 9.1 [32] and the calculated temperature showed
319 a difference of only 0.35% with respect to the nominal value.

320

321 **Table 3:** Performance of the selected ICE-based CHP unit. The available thermal power is calculated
 322 assuming that the exhaust gases and jacket water are cooled down to 120 °C and 80 °C, respectively.

Electrical output (kW)	185	Thermal power from exhaust gas (kW)	98
Electrical efficiency (%)	33.6	Thermal power from jacket water (kW)	210
Thermal power output (kW)	308	Exhaust mass flow rate (kg/h)	721
Thermal efficiency (%)	56.1	Water inlet temperature (°C)	90
Total efficiency (%)	89.7	Water mass flow rate (kg/s)	5.0
Exhaust gas temperature (°C)	570		

323
 324 While 68% of the total heat is rejected in the jacket cooling water system (against 32% in the
 325 exhaust-gas stream), as shown in Table 3, this work is focused on the recovery of the waste heat
 326 from the exhaust gases, as the thermal energy in this stream is available at significantly higher
 327 temperatures. An exergy analysis supports this choice, by determining the maximum useful power
 328 that can be produced with a reversible heat engine recovering heat from the exhaust-gas, \dot{X}_{exh} , and
 329 jacket-water streams, \dot{X}_w :

$$\dot{X}_{\text{exh}} = \dot{m}_{\text{exh}}[h_{\text{exh,in}} - h_{\text{exh,out}} - T_0(s_{\text{exh,in}} - s_{\text{exh,out}})], \quad (1)$$

$$\dot{X}_w = \dot{m}_w[h_{w,\text{in}} - h_{w,\text{out}} - T_0(s_{w,\text{in}} - s_{w,\text{out}})]. \quad (2)$$

332
 333 In the analysis, the exhaust gases are cooled down to $T_{\text{exh,out}} = 120$ °C and the jacket water down to
 334 $T_{w,\text{out}} = 80$ °C, according to the limits specified by the manufacturer.

335
 336 Figure 2 shows that, although twice as much thermal power is released in the jacket water as in the
 337 exhaust gases, the reversible power output is higher for the exhaust gases as their temperature is
 338 much higher. More than half of the thermal power available in the exhaust gas flow (50.5%, i.e.,
 339 49.5 kW) has the potential to be converted into useful work, compared to only 18.1% (i.e., 38 kW)
 340 for the jacket water. This analysis justifies the choice to recover heat from the exhaust gases rather
 341 than from the jacket water. In addition, hot water from the jacket could be easily used for space
 342 heating at medium-low temperature, while exhaust gases at higher temperature can be used for
 343 electricity generation using ORC systems.

344

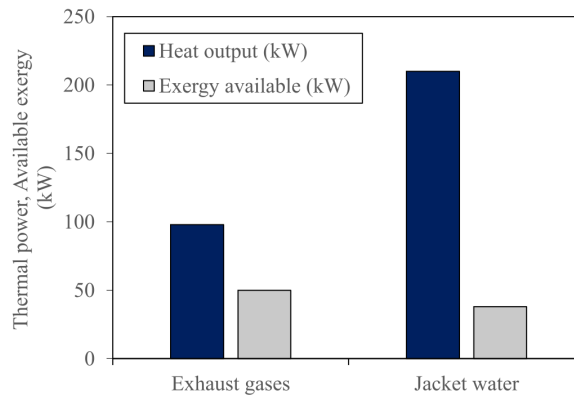

345
 346 **Figure 2:** Thermal power and reversible power output available for the E185 engine.

347 2.2 ORC system model

348
 349 A sub-critical and non-regenerative cycle configuration is considered in this work (see Figure 3).
 350

351 Although a regenerator can improve ORC engine performance, it is not included in the present
 352 work as it would lead to increased heat exchanger costs and system complexity with only minor
 353 performance improvements [33]. Since the power generated by the ORC system is in the range of
 354 10 to 20 kW_e, a screw expander and a reciprocating-piston expander are selected for the energy
 355 conversion process. Turbines can be challenging to design for this power range because of their
 356 need to operate at very high rotational speeds.
 357

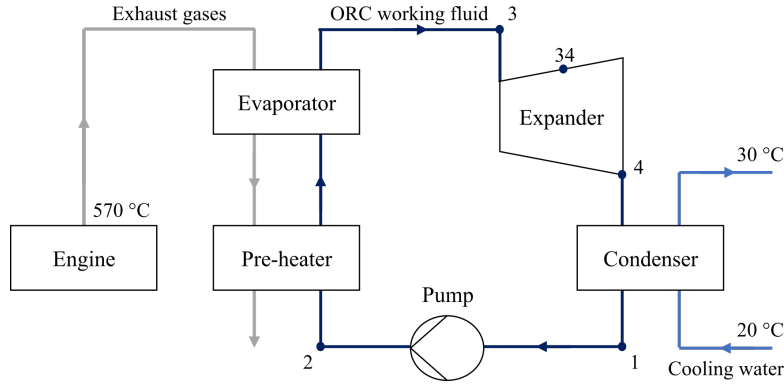

358
 359 **Figure 3:** Schematic of the ORC system recovering heat from the internal combustion engine
 360 exhaust gases and rejecting heat to cooling water.
 361

362 Of the selected expander types, screw expanders are the more mature technology, with the
 363 following advantages: (i) compact design [18]; (ii) capability to adjust the volume ratio with the
 364 use of a slide valve in order to maximise the device efficiency at off-design conditions [30]; and
 365 (iii) capability to handle expansion in the presence of liquid droplets in two-phase flow. On the
 366 other hand, reciprocating-piston expanders show high isentropic efficiencies at high pressure ratios
 367 and good part-load performance. Relative to screw machines, their use for two-phase expansion
 368 needs to be approached with care, and although losses arise due to valve flows and the clearance
 369 volume, they can typically achieve lower leakage rates.
 370

371 Many ORC engine studies assume a constant isentropic efficiency for the expander, which can lead
 372 to expander operating points that are challenging to achieve in practice. An alternative approach is
 373 to incorporate expander performance maps within the cycle optimisation, helping to ensure optimal
 374 matching of the cycle and expander. Astolfi [30] collated data on a set of Bitzer open screw
 375 compressors and mapped their efficiency against volume ratio and volumetric flow rate. As the
 376 compressors can be converted into expanders with relatively minor modifications, this dataset can
 377 be used as a surrogate for screw expander performance. As a range of machines were considered,
 378 the resulting surface fit gives an estimate for possible full-load performance available at different
 379 operating points.
 380

381 Performance maps for reciprocating-piston expanders cannot be generated in the same way. This is
 382 due to the fact that piston expanders require active valve control, unlike piston compressors, which
 383 operate with passively-actuated valves. The performance maps are therefore obtained via a dynamic
 384 lumped-mass model [31], developed in MATLAB. The model incorporates valve losses, heat transfer
 385 and leakage flows, and both the model formulation and validation are described in greater detail by
 386 Chatzopoulou [34]. A set of decision variables is used to parameterise a generic expander design,
 387 including the bore, stroke, clearance height, and valve opening and closing times. An optimisation
 388 routine has been developed to identify high-performing designs over a range of operating conditions,
 389 according to the methodology outlined in Simpson et al. [35]. For each operating condition, the

390 objective function is to maximise power output per unit mass flow rate of working fluid. An artificial-
 391 neural-network surrogate model is used to fit a surface to the outputs of the lumped-mass model (mass
 392 flow rate and isentropic efficiency) for different designs and operating conditions, which can then be
 393 evaluated rapidly during an optimisation using a genetic algorithm approach. An iterative approach is
 394 followed, with further lumped-mass model evaluations used to refine the neural-network surrogate
 395 with each iteration. The resulting designs are combined into performance maps across a range of mass
 396 flow rates, pressure ratios and expander inlet temperatures. The properties of the organic working fluid
 397 (wf) are calculated using REFPROP 9.1 [32].
 398

399 In this work, three configurations are analysed for the expansion process: a single-stage screw
 400 expander, a single-stage piston expander and a two-stage screw expander, in a series configuration.
 401 A two-stage piston expander is not considered because of the higher pressure-ratio capability of
 402 the piston expander within a single stage.
 403

404 The following assumptions are considered for the ORC system model:

- 405 • Each component of the cycle operates under steady-state conditions.
- 406 • Heat losses to or from the surroundings are neglected.
- 407 • Friction losses in the connecting pipes are neglected.
- 408 • Kinetic and potential energy of the flowing fluid are neglected.
- 409 • Heat transfer in the heat exchangers is calculated for fully-developed flow.

410
 411 The basic equations for the energy analysis are given below.

412
 413 The power required to pump the working fluid from State 1 (saturated fluid) to State 2, as in Figure
 414 4, is:
 415

$$\dot{W}_{\text{pump}} = \dot{m}_{\text{wf}}(h_2 - h_1) = \frac{\dot{m}_{\text{wf}}(h_{2,\text{is}} - h_1)}{\eta_{\text{is,pump}}}, \quad (3)$$

416
 417 where $\eta_{\text{is,pump}}$ is the pump isentropic efficiency, defined as:
 418

$$\eta_{\text{is,pump}} = \frac{h_{2,\text{is}} - h_1}{h_2 - h_1}. \quad (4)$$

419
 420 To study the influence of the superheating on the performance of the system, a non-dimensional
 421 parameter, d_{SH} , (which can vary between 0 and 1) is employed. It is known that in some case the
 422 superheating is detrimental for the performance of the cycle and this parameter allows the working
 423 fluid to exit the heating process either as saturated vapour or as superheated vapour:
 424

$$d_{\text{SH}} = \frac{T_3 - T_{3v}(p_{\text{evap}})}{T_{\text{max}} - T_{3v}(p_{\text{evap}})}. \quad (5)$$

425
 426 Here, T_{max} is the maximum temperature of the working fluid, defined as follows:
 427

$$T_{\text{max}} = \begin{cases} T_{\text{hs,in}} - \Delta T_{\text{pp}} & \text{if } T_{\text{max,wf}} > T_{\text{hs,in}} - \Delta T_{\text{pp}} \\ T_{\text{max,wf}} & \text{if } T_{\text{max,wf}} < T_{\text{hs,in}} - \Delta T_{\text{pp}} \end{cases}, \quad (6)$$

428
 429 where ΔT_{pp} is the minimum allowed temperature difference at the pinch point; $T_{\text{max,wf}}$ is the

430 maximum temperature at which thermal stability of the working fluid can be maintained, provided
 431 by REFPROP 9.1. Thus, the heat extracted from the heat source (hs) is given by:

$$432 \quad \dot{Q}_{\text{in}} = \dot{m}_{\text{hs}}(h_{\text{hs,in}} - h_{\text{hs,out}}), \quad (7)$$

433 which is equal to the heat transferred to the working fluid:
 434

$$435 \quad \dot{Q}_{\text{in}} = \dot{m}_{\text{wf}}(h_3 - h_2). \quad (8)$$

436 If a single-stage expansion is considered, the power generated by the expander is:
 437

$$438 \quad \dot{W}_{\text{exp}} = \dot{m}_{\text{wf}}(h_3 - h_4) = \eta_{\text{is,exp}} \dot{m}_{\text{wf}}(h_3 - h_{4,\text{is}}). \quad (9)$$

439 In the case of two-stage expansion, defining the outlet of the first expander as ‘34’, and the isentropic
 440 exit state as ‘34,is’, the generated power is the sum of the following two contributions:
 441

$$442 \quad \dot{W}_{\text{exp},1} = \dot{m}_{\text{wf}}(h_3 - h_{34}) = \eta_{\text{is,exp1}} \dot{m}_{\text{wf}}(h_3 - h_{34,\text{is}}), \text{ and} \quad (10)$$

$$443 \quad \dot{W}_{\text{exp},2} = \dot{m}_{\text{wf}}(h_{34} - h_4) = \eta_{\text{is,exp2}} \dot{m}_{\text{wf}}(h_{34} - h_{4,\text{is}}), \quad (11)$$

444 where the isentropic efficiency of the screw expander is provided by Astolfi [30] as:
 445

$$446 \quad \eta_{\text{is,scr}} = c \left[0.940 + 0.0293 \ln(\dot{V}_{\text{out}}) - 0.0266 V_r \right], \text{ with} \quad (12)$$

$$447 \quad c = 1 - 0.264 \ln\left(\frac{V_r}{7}\right) \quad \text{for } V_r > 7, \quad (13)$$

448 with \dot{V}_{out} being the isentropic volumetric flow rate at the outlet of the expander and V_r the volume
 449 ratio across the stage.
 450

451 For the piston expander, a 3-D lookup table of isentropic efficiency as a function of mass flow rate,
 452 pressure ratio and superheat temperature, T_{sh} , is used for each fluid:
 453

$$454 \quad \eta_{\text{is,pis}} = f\left(\dot{m}_{\text{wf}}, \frac{p_{\text{evap}}}{p_{\text{cond}}}, T_{\text{sh}}\right). \quad (14)$$

455 After the expander, the working fluid rejects heat to the cooling stream (cs). The thermal power
 456 output from the working fluid is given by:
 457

$$458 \quad \dot{Q}_{\text{out}} = \dot{m}_{\text{wf}}(h_4 - h_1), \quad (15)$$

459 which is equal to the heat received by the cooling stream:
 460

$$461 \quad \dot{Q}_{\text{out}} = \dot{m}_{\text{cs}}(h_{\text{cs,out}} - h_{\text{cs,in}}). \quad (16)$$

462 The net mechanical power output is:
 463

$$464 \quad \dot{W}_{\text{net}} = \dot{W}_{\text{exp}} - \dot{W}_{\text{p}}, \quad (17)$$

465 and the first-law efficiency (also referred to as thermal efficiency) is defined as:
 466

$$\eta_{th} = \frac{\dot{W}_{net}}{\dot{Q}_{in}}. \quad (18)$$

467
 468 The loss of useful energy of the system or device is not quantified by the first law of
 469 thermodynamics since it does not make a distinction between quality and quantity of energy [36].
 470 The exergy analysis, based on the second law of thermodynamics, is a useful method in the design,
 471 evaluation, optimisation and improvement of energy systems. Thanks to this kind of analysis, it is
 472 possible to understand the location, cause and magnitude of the lost potential to do work in an
 473 energy conversion system.
 474

475 In the current work, the heat sink inlet temperature (20 °C) and the atmospheric pressure (1 atm)
 476 are taken as the reference-state temperature and pressure. The equations for the ORC system exergy
 477 analysis are given below.
 478

479 The exergy received by the fluid in the pump is:
 480

$$\dot{X}_{pump} = \dot{m}_{wf}[h_2 - h_1 - T_0(s_2 - s_1)], \quad (19)$$

481
 482 while the destroyed exergy in the pump is:
 483

$$\dot{I}_{pump} = T_0 \dot{m}_{wf}(s_2 - s_1). \quad (20)$$

484
 485 The exergy supplied by the heat source is computed as:
 486

$$\dot{X}_{hs} = \dot{m}_{hs}[h_{hs,in} - h_{hs,out} - T_0(s_{hs,in} - s_{hs,out})]. \quad (21)$$

487
 488 The exergy received by the working fluid is:
 489

$$\dot{X}_{wf,in} = \dot{m}_{wf}[h_3 - h_2 - T_0(s_3 - s_2)]. \quad (22)$$

490
 491 Therefore, the destroyed exergy in the evaporator is:
 492

$$\dot{I}_{evap} = \dot{X}_{hs} - \dot{X}_{wf,in} = T_0[\dot{m}_{hs}(s_{hs,out} - s_{hs,in}) + \dot{m}_{wf}(s_3 - s_2)]. \quad (23)$$

493
 494 The available exergy for a single stage expansion is:
 495

$$\dot{X}_{exp} = \dot{m}_{wf}[h_3 - h_4 - T_0(s_3 - s_4)], \quad (24)$$

496
 497 and the destroyed exergy in the expander is given by:
 498

$$\dot{I}_{exp} = T_0 \dot{m}_{wf}(s_4 - s_3). \quad (25)$$

499
 500 Exergy supplied to the cooling water during the condensation process is:
 501

$$\dot{X}_{cond} = \dot{m}_{wf}[h_4 - h_1 - T_0(s_4 - s_1)]. \quad (26)$$

502

503 The exergy received by the cooling water is computed as:

504
$$\dot{X}_{cs} = \dot{m}_{cs} [h_{cs,out} - h_{cs,in} - T_0 (s_{cs,out} - s_{cs,in})]. \quad (27)$$

505
506 And the destroyed exergy in the condenser is:

507
$$\dot{i}_{cond} = \dot{X}_{cond} - \dot{X}_{cs} = T_0 [\dot{m}_{wf}(s_1 - s_4) + \dot{m}_{cs}(s_{cs,out} - s_{cs,in})]. \quad (28)$$

508
509 Finally, the total flow rate of the irreversibility in the ORC system is the sum of destroyed exergy
510 in each component:

511
$$\dot{i}_{tot} = \sum_{i \in \text{Components}} \dot{i}_i, \quad (29)$$

512
513 and the final exergy balance of ORC system is written as:

514
$$\dot{X}_{hs} + \dot{W}_{pump} = \dot{W}_{exp} + \dot{X}_{cs} + \dot{i}_{tot}. \quad (30)$$

515
516 The exergy (second-law) efficiency is computed by the following equation:

517
$$\eta_{ex} = \frac{\dot{W}_{exp} - \dot{W}_{pump}}{\dot{X}_{hs}}, \quad (31)$$

518
519 where the available input exergy is the exergy change in the heat source calculated by Eq. (21).

520
521 In order to obtain a low-cost configuration, counter-current double-pipe heat exchangers are chosen.
522 The heat addition process takes place in two heat exchangers: a pre-heater (PH) used to heat the
523 working fluid to saturated liquid and an evaporator (Ev) in which the working fluid is vaporised and
524 superheated if necessary. Likewise, the heat rejection process is carried out in a desuperheater (DSh)
525 and a condenser (Cn). The former brings the working fluid to saturated vapour from the expander
526 outlet whereas the latter condenses it to saturated liquid.

527
528 The heat exchanger designs are carried out considering standard/nominal pipe diameters. The sizes
529 are selected to provide turbulent flow regimes for each fluid, while maintaining reasonably low
530 velocities in both pipes. In particular, velocities of 1.5 m/s for liquids and 30 m/s for vapour are
531 considered as upper limits [37]. The heat exchangers are assumed to be constructed in stainless
532 steel (thermal conductivity $k = 24 \text{ W.m}^{-1}.\text{K}^{-1}$ since they must withstand hot organic fluids and/or
533 exhaust gases).

534
535 For modelling purposes, each heat exchanger is discretised into 100 segments of variable sizes,
536 with an equal quantity of heat transferred in each. In all heat exchangers, the working fluid flows
537 through the inner pipe (ip) whereas the heat source and sink stream through the outer pipe (op). A
538 segment is depicted in Figure 4.

539

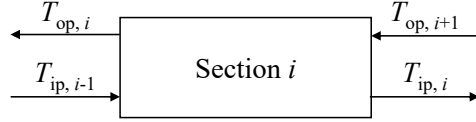

Figure 4: Heat exchanger segment (op: outer pipe; ip: inner pipe).

Thus, the total heat fluxes transferred to/from the working fluid (referring to Eqs. (8) and (15), respectively) are given by:

$$\dot{Q}_{\text{in}} = \dot{Q}_{\text{PH}} + \dot{Q}_{\text{Ev}} = \sum_{i=1}^{100} \dot{Q}_{\text{PH},i} + \sum_{i=1}^{100} \dot{Q}_{\text{Ev},i}, \quad (32)$$

$$\dot{Q}_{\text{out}} = \dot{Q}_{\text{DSh}} + \dot{Q}_{\text{Cn}} = \sum_{i=1}^{100} \dot{Q}_{\text{DSh},i} + \sum_{i=1}^{100} \dot{Q}_{\text{Cn},i}. \quad (33)$$

For each segment i , an overall heat transfer coefficient U_i , is calculated as follows:

$$\frac{1}{U_i} = \frac{1}{h_{\text{op},i}} + \frac{\Delta x}{k} + \frac{1}{h_{\text{ip},i}}. \quad (34)$$

Once the overall heat-transfer coefficient for each segment is known, the heat transfer area can be calculated from the following equation for counter-current flows:

$$\dot{Q}_i = U_i A_i \Delta T_{\text{lm},i}, \quad (35)$$

where $\Delta T_{\text{lm},i}$ is the logarithmic average temperature difference for the segment i :

$$\Delta T_{\text{lm},i} = \frac{(T_{\text{op},i+1} - T_{\text{ip},i}) - (T_{\text{op},i} - T_{\text{ip},i-1})}{\ln \left(\frac{T_{\text{op},i+1} - T_{\text{ip},i}}{T_{\text{op},i} - T_{\text{ip},i-1}} \right)}. \quad (36)$$

Single-phase (sp) and two-phase (tp) local heat transfer coefficients (HTCs) are calculated as follows. For single-phase flow, the local HTCs ($h_{\text{op},i}$, $h_{\text{ip},i}$) are computed using the well-known Dittus-Boelter Nusselt ($Nu_{\text{sp},i}$) number correlation.

$$Nu_{\text{sp},i} = 0.023 \cdot Re_i^{0.8} \cdot Pr_i^n, \quad (37)$$

where the exponent n is 0.3 for cooling and 0.4 for the heating.

Defining \dot{m}_{fl} as the mass flux, D_{ip} as the inner pipe diameter, μ as the dynamic viscosity, k as the thermal conductivity and c_p as the isobaric specific heat capacity, the Reynolds and Prandtl numbers are computed as follows:

$$\dot{m}_{\text{fl}} = \frac{4 \cdot \dot{m}_{\text{wf}}}{\pi D_{\text{ip}}^2}; \quad Re_i = \frac{\dot{m}_{\text{fl}} D_{\text{ip}}}{\mu_i}; \quad Pr_i = \frac{c_{p,i} \mu_i}{k_i}. \quad (38)$$

570 Thus, the local HTC for the working fluid side is given as:
571

$$h_{ip,i} = \frac{Nu_{sp,i} \cdot k_i}{D_{ip}}. \quad (39)$$

572
573 The local HTCs in the two-phase regions of the heat exchangers is calculated from the two-phase
574 Nusselt number, $Nu_{tp,i}$, obtained by modifying the single-phase Nusselt number, $Nu_{sp,i}$, with
575 empirical correlations of the Lockhart-Martinelli parameter, X_{tt} [38,39]:
576

$$Nu_{tp,i} = F(X_{tt})Nu_{sp,i}; \quad F(X_{tt}) = 1 + 1.8 \left(\frac{1}{X_{tt}} \right)^{0.82}, \quad (40)$$

577

$$X_{tt} = \left(\frac{1-q}{q} \right)^{0.9} \left(\frac{\rho_v}{\rho_l} \right)^{0.5} \left(\frac{\mu_l}{\mu_v} \right)^{0.1}, \quad (41)$$

578

$$h_{ip} = \frac{Nu_{tp,i} \cdot k_i}{D_{ip}} [1 - 0.533(|y-x|)^{0.828}], \quad (42)$$

579 where q is the vapour quality (on a mass basis) and x and y are the liquid- and vapour-phase
580 composition (mass fractions). Equations (40) and (41) can be directly applied for pure fluids using the
581 overall composition for the liquid and vapour-phase properties [40]. The total heat transfer area is
582 given by the sum of the areas for all segments is calculated from Eq. (35).
583
584

585 3. Cost estimation

586
587 To obtain reliable results from the thermoeconomic analysis, accurate information about the
588 equipment costs are needed. Engineering companies and component manufacturers hold this data
589 but treat it as confidential for the most part.
590

591 Three main references are used to obtain cost correlations. The first, Perry's Chemical Engineers'
592 Handbook [41] provides cost correlations for various components of chemical engineering
593 processes in the following form:
594

$$C = C_0 \left(\frac{q}{q_0} \right)^m, \quad (43)$$

595
596 where C_0 and q_0 are the capital cost and the capacity of the reference component, respectively,
597 whereas q is the capacity of the component whose cost is unknown. The exponent m expresses the
598 deviation from the linear trend considering size effect on the equipment cost and is usually below
599 1. The above approach, known as exponential method, is the most common in engineering for fast
600 cost estimations. The main drawback lies in the definition of just one reference point and one
601 exponent. Errors in the estimation of these parameters lead to high deviation of the estimation costs
602 especially for a component size far from the reference values.
603

604 For many components of interest in the ORC engine field, Seider et al. [42] represents another
605 useful source of data for the design of chemical and synthesis processes, providing a detailed
606 methodology for the calculation of equipment cost. Unlike Perry's approach, it does not present
607 deviation issues for values far from references and accuracy is stated to be in the range of $\pm 25\%$.

608 The data used for these correlations were gathered in 2006 and the base cost functions are provided
 609 as logarithmic correlations of the form:

$$610 \quad C = \exp\{A_0 + A_1[\ln(S)] + A_2[\ln(S)]^2 + \dots\}, \quad (44)$$

611 where A_i are constants, while S is the component's most important reference quantity (surface for
 612 heat exchangers, volume flow rate for pumps, etc.). The equations are usually based on the most
 613 common materials of construction, such as carbon steel. For other materials, multiplying
 614 coefficients are provided.
 615

616 Finally, the NETL (National Energy Technology Laboratory) report [43] is the result of work
 617 funded by the US government and it follows the approach of Seider for the estimation of base
 618 equipment cost. Data are provided as curves of capital cost against size for various components. In
 619 the present work, the correlations provided by Seider [42] are employed because of their more
 620 recent publication date, such that variations introduced by year-to-year conversion with the
 621 Chemical Engineering Plant Cost Index (CEPCI) are minimised.
 622

623 The previous references can be used for the estimation of the cost of the common components such
 624 as double-pipe heat exchangers, S&T heat exchangers, generators and pumps. Unfortunately, there
 625 are few published studies on the cost of expanders. Among these, Astolfi [30] proposed a cost
 626 correlation for screw compressors, derived from the cost of more than 100 commercial
 627 compressors, consuming between 3.7 and 184 kW. This correlation, given below in Eq. (50), is a
 628 linear function of the volumetric flow rate at the exit of the machine, \dot{V}_{out} , expressed in m^3/s , this
 629 being the primary parameter that affects the size and the cost of these devices.
 630

631 The cost correlations for each component are presented below.

632 Centrifugal pump

633 The size factor S is:

$$634 \quad S = 15850 \dot{V}_{pump} \sqrt{3.28 H}, \quad (45)$$

635 where \dot{V}_{pump} is the flow rate through the pump in m^3/s and H is the pump head in metres. The cost
 636 in dollars is given as:
 637

$$638 \quad C_{pump} = \exp\{9.72 - 0.602[\ln(S)] + 0.0519[\ln(S)]^2\}. \quad (46)$$

639 The cost of the electric motor that drives the pump is given in Eq. (47). This cost is added to the
 640 pump cost. The size parameter is the power absorbed by the pump in kW.
 641

$$642 \quad C_{motor} = \exp\left\{5.83 + 0.131[\ln(1.341 \dot{W}_{pump})] \right. \\
 643 \quad \quad \quad + 0.0533[\ln(1.341 \dot{W}_{pump})]^2 \\
 644 \quad \quad \quad + 0.0286[\ln(1.341 \dot{W}_{pump})]^3 \\
 645 \quad \quad \quad \left. - 0.00355[\ln(1.341 \dot{W}_{pump})]^4\right\}. \quad (47)$$

646

647 Double-pipe heat exchangers

648
649 The cost correlation is based on carbon-steel heat exchanger, with the area A in m^2 :
650

$$C_{B,HE} = \exp\{7.15 + 0.16[\ln(10.8 A)]\}. \quad (48)$$

651
652 The final purchase cost is determined from:
653

$$C_{HE} = F_P F_M C_{B,HE}, \text{ where} \quad (49)$$

$$F_P = 0.851 + 0.129 \left(\frac{p - 101300}{41.4} \right) + 0.0198 \left(\frac{p - 101300}{41.4} \right)^2, \quad (50)$$

655
656 F_P is the pressure factor and the material factor, F_M , is 2 for an outer pipe of carbon steel and an
657 inner pipe of stainless steel.

658
659 Screw expander

660
661 As screw compressors can be modified to operate in reverse mode as expanders, the correlation
662 from Astolfi [30] is used. The size parameter is the volumetric flow rate at the end of the expansion
663 in m^3/s and the cost is expressed in \$.
664

$$C_{exp,scr} = 3144 + 217400 \dot{V}_{out}, \quad (51)$$

665
666 Piston expander

667
668 A similar approach is taken to estimate the cost of reciprocating-piston expanders, again drawing
669 on volumetric flow rate as the characteristic parameter for costing [44].
670

$$C_{exp,pis} = 1319 + 294500 \dot{V}_{out}. \quad (52)$$

671
672 It is noted that the cost of the electric generator is not considered for either expander, since it is
673 assumed that the expander would be mechanically connected to the generator of the CHP unit.
674

675 Finally, the costs of the pump, expander and heat exchangers are summed up to give an estimate
676 of the power block cost C_{PB} .
677

$$C_{PB} = C_{pump} + C_{motor} + C_{exp} + C_{PH} + C_{Ev} + C_{DSh} + C_{Cn}. \quad (53)$$

678
679 **4. Fluid selection**

680
681 The working fluid used in the ORC system directly impacts the safety, size, performance and cost-
682 effectiveness of the system. With the aim of narrowing down the vast list of possible fluids the
683 following criteria are used:

- 684 • Global warming potential (GWP) ≤ 1430 (R134a)
- 685 • Ozone depletion potential (ODP) ≤ 0.01
- 686 • Health (NFPA) \leq Moderate hazard (2)
- 687 • Instability (NFPA) \leq low hazard (1)

688 According to those criteria, 18 fluids that meet the above requirements are considered in the
 689 simulations using the same boundary conditions and assumptions about the equipment. All necessary
 690 fluid properties are calculated from the NIST database using REFPROP 9.1. The environmental
 691 criteria eliminate the use of the chlorofluorocarbons and hydrochlorofluorocarbons, as they exhibit
 692 high ODPs and are being phased out [45]. Perfluorocarbons have no ODP, but are chemically very
 693 stable, resulting in very long (>1000 years) lifetimes in the atmosphere due to the high numbers of
 694 carbon-fluorine bonds. Thus, they are also eliminated. The US NFPA (National Fire Protection
 695 Association) 704 standard is used to assess the fluids toxicity and stability. Assuming the maximum
 696 NFPA health hazard limit of 2 (moderate), fluids like carbon-disulfide and allyl-chloride are rejected
 697 as well. The 18 fluids analysed are listed along with their main properties in Tables 4 to 6. They can
 698 be classified into alkanes, refrigerants, and others.

700 **Table 4:** Main properties of alkanes. T_{\max} is the value reported by REFPROP and is representative
 701 of the decomposition temperature; H, F and I are safety information indexes according to NFPA
 702 classification (H, health; F, flammability; I, instability), with each index ranging from 0-no hazard
 703 to 4-maximum hazard; ODP is the ozone depletion potential index; and GWP is the global warming
 704 potential index.

Working fluid	M (kg/kmol)	T_{crit} (°C)	p_{crit} (bar)	T_{max} (°C)	H	F	I	ODP	GWP
Propane	44	97	42	377	1	4	0	0	
Butane	58	152	38	302	1	4	0	0	
Iso-pentane	72	187	34	227	1	4	0	0	
Pentane	72	197	34	327	1	4	0	0	
Iso-hexane	86	225	30	277	2	3	0	0	4-6
Hexane	86	235	30	327	2	4	0	0	
Heptane	100	267	27	327	1	3	0	0	
Octane	114	296	25	327	1	3	0	0	
Cyclopentane	70	239	46	277	1	3	0	0	
Cyclohexane	84	281	41	427	1	3	0	0	

705
 706
 707 **Table 5:** Main properties of refrigerants. T_{\max} is the value reported by REFPROP and is
 708 representative of the decomposition temperature; H, F and I are safety information indexes
 709 according to NFPA classification (H, health; F, flammability; I, instability), with each index
 710 ranging from 0-no hazard to 4-maximum hazard; ODP is the ozone depletion potential index; and
 711 GWP is the global warming potential index.

Working fluid	M (kg/kmol)	T_{crit} (°C)	p_{crit} (bar)	T_{max} (°C)	H	F	I	ODP	GWP
R1234yf	114	95	34	137	1	4	0	0	4
R134a	102	101	41	182	1	0	1	0	1430
R161	48	102	50	177	1	4	0	0	12
R245fa	134	154	36	167	2	1	0	0	1030
R365mfc	148	187	33	227	0	4	1	0	794

712
 713 **Table 6:** Main properties of other fluids considered. T_{\max} is the value reported by REFPROP and
 714 is representative of the decomposition temperature; H, F and I are safety information indexes
 715 according to NFPA classification (H, health; F, flammability; I, instability), with each index

716 ranging from 0-no hazard to 4-maximum hazard; ODP is the ozone depletion potential index; and
 717 GWP is the global warming potential index.

Working fluid	M (kg/kmol)	T_{crit} (°C)	p_{crit} (bar)	T_{max} (°C)	H	F	I	ODP	GWP
Acetone	58	235	47	277	1	3	0	0	n/a
Toluene	92	319	41	427	2	3	0	-	0
Ethanol	46	242	63	365	2	3	0	0	320-670

718
 719 **5. System optimisation**

720
 721 In the present work, two optimal configurations are studied, using different objective functions.
 722 The first considers the maximisation of the power output, for a pure thermodynamic optimisation;
 723 the second minimises the specific investment cost, for a thermoeconomic optimisation. Both screw
 724 and piston expanders are considered. As the heat source temperature is high, corresponding to large
 725 cycle pressure ratios, a two-stage screw expander is also analysed to help address the pressure ratio
 726 per stage limitations of screw expanders. The selected optimisation variables are: evaporating
 727 pressure, condensing pressure, degree of superheating and mass flow rate of the working fluid. The
 728 remaining properties of the cycle can be derived from those variables. The interior point algorithm
 729 is employed for the optimisation [46].

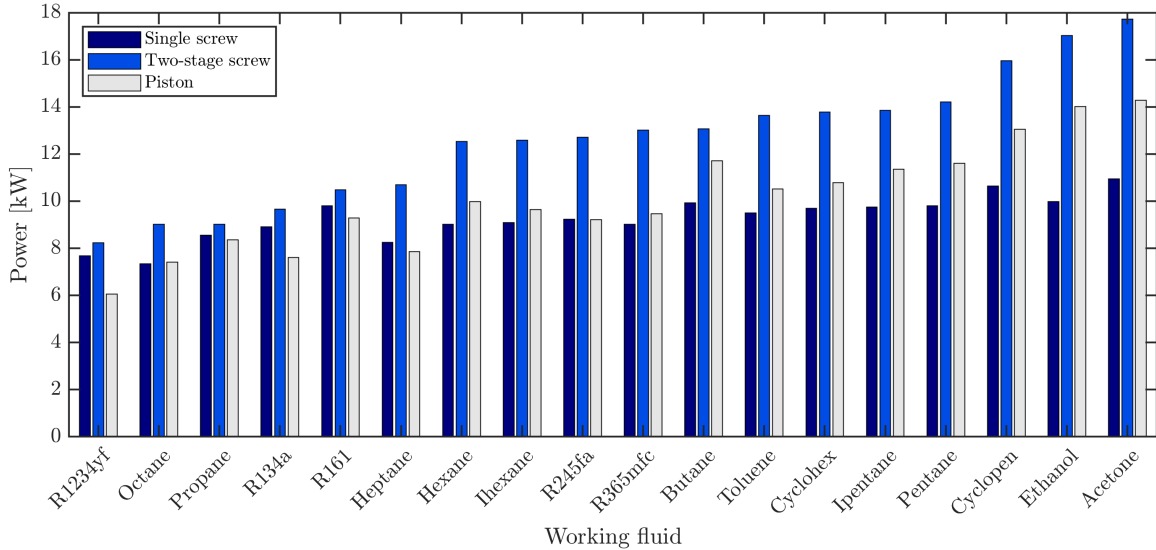

730
 731 **Figure 5:** Comparison of maximum power outputs between single- and two-stage expanders using
 732 the 18 selected fluids. Each data point is obtained by optimising the ORC operating parameters
 733 (p_{evap} , p_{cond} , d_{SH} and \dot{m}_{wf}) so as to generate the maximum net power output, \dot{W}_{net} .

734
 735 **5.1 Thermodynamic optimisation**

736
 737 The thermodynamic optimisation is designed to identify the ORC operating parameters p_{evap} , p_{cond} ,
 738 d_{SH} and \dot{m}_{wf} that maximise the net power output, \dot{W}_{net} subject to the following constraints:

$$\left\{ \begin{array}{l} p_{cond} \leq p_{evap} \leq 0.95 p_{crit} \\ 0 \leq d_{SH} \leq 1 \\ \Delta T \geq 10 \text{ } ^\circ\text{C} \\ T_{hs,out} \geq 120 \text{ } ^\circ\text{C} \\ p_{cond} \geq 1 \text{ bar} \end{array} \right. \quad (54)$$

740

741 The evaporator pressure is limited by the first constraint to keep the cycle subcritical, while the
742 amount of superheating is controlled by the second. The temperature difference between the working
743 fluid and the heat or sink source (ΔT) is always greater than 10 °C. In addition, the outlet temperature
744 of the exhaust gases remains above 120 °C, according to manufacturer requirements. The heat sink
745 is cooling water, which enters the condenser at 20 °C, with the flow rate varying such that it exits at
746 30 °C. The maximum temperature of the working fluid is limited according to the decomposition
747 temperature provided by REFPROP. Finally, sub-atmospheric operation is prevented by imposing a
748 lower limit for the condensing pressure of 1 bar.
749

750 The optimised power output obtained for each fluids and the three expanders configurations is shown
751 in Figure 5. It shows that the best fluids are acetone and ethanol, except in the case of the single-stage
752 screw expander for which cyclopentane provides slightly more power than ethanol. For most of the
753 fluids there is a remarkable difference in terms of power output between single- and two-stage screw
754 expanders. This is due to the dependency of the efficiency of the screw expander on the volume ratio.
755 With the exception of fluids with very low critical temperature, the optimal volume ratio for the
756 single-stage configuration is always slightly above 7, as this is where the Astolfi correlation predicts
757 a drop-off in efficiency.
758

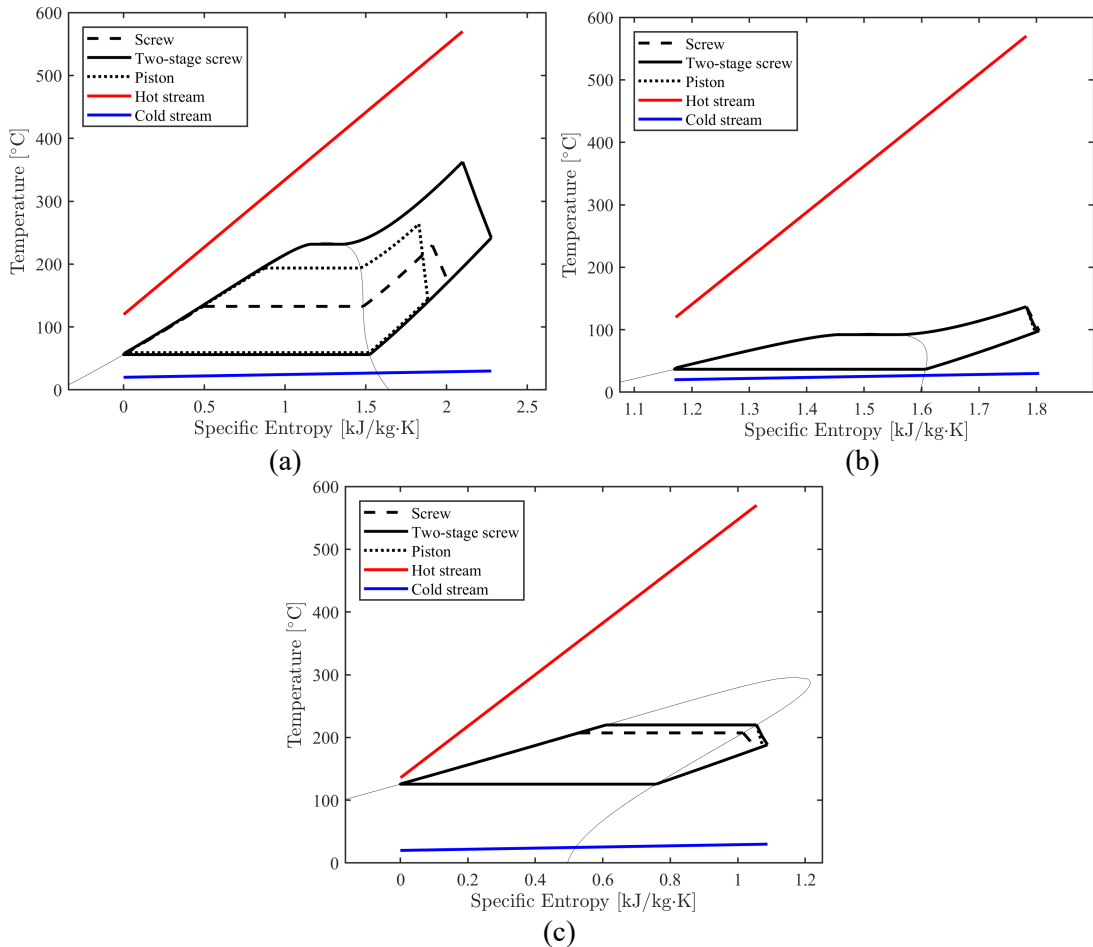

759

760

761

762

763

764

Figure 6: *T-s* diagram for an ORC engine optimised for maximum net power with: (a) acetone, (b) R1234yf, and (c) octane as working fluids, with a screw expander (dashed line), piston expander

765 (dotted line), and two-stage screw expander (solid line).
766

767 Figure 6 shows the thermodynamic cycles of the ORC systems using acetone, R1234yf and octane
768 as working fluid, which are representative of fluids with intermediate, low, and high critical
769 temperature respectively, in combination with the three types of expanders. Using the two-stage
770 expander, it is possible to increase the cycle pressure ratio, and achieve an improved temperature
771 match with the heat source, and thus a higher power output. Similarly, for a given overall pressure
772 ratio, by using two expanders it is possible to reduce the volume ratio across each expander, so
773 increasing the isentropic efficiency and the power output [30]. Table 7 provides the power output and
774 the optimal cycle parameters for the piston expander with acetone, R1234yf, and octane.

775 Fluids with very low critical temperatures, such as R1234yf, propane, R134a and R161, are seen
776 to be poorly suited for this application. Their critical temperatures range between 95 and
777 105 °C [32], which leads to poor matching with the heat-source temperature. The cycle pressure
778 ratio is strongly constrained, and this leads to cycles with low exergy efficiency. For these fluids,
779 the minimum approach temperature of 10 °C is achieved at the inlet of the condenser and the main
780 exergy losses take place in the evaporator (see Figure 7). The high evaporating and condensing
781 pressures (see Table 5 for R1234yf) are another reason for fluids with low critical temperature
782 being unsuitable for this application, as these pressures call for thicker tubes in the heat exchangers,
783 which are more expensive [42].
784

785 **Table 7:** Cycle parameters for an ORC engine optimised for maximum net power, with a piston
786 expander with acetone, R1234yf, and octane.

	Acetone	R1234yf	Octane
\dot{W}_{net} (kW)	14.3	6.1	7.4
p_{evap} (bar)	24.9	32.1	7.9
p_{cond} (bar)	1.13	9.35	1.01
\dot{m}_{wf} (kg/s)	0.12	0.44	0.19
d_{sh}	0.26	1.00	0.35
η_{exp}	0.64	0.58	0.63
η_{th}	0.15	0.06	0.08
η_{ex}	0.29	0.12	0.15

787
788
789
790
791
792

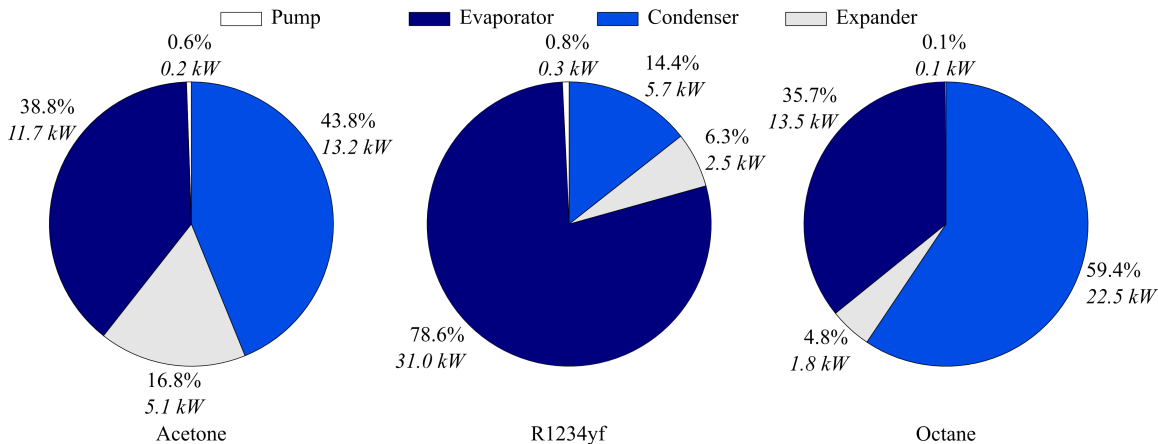

793
794 **Figure 7:** Distribution of exergy losses for an ORC engine optimised for maximum net power,
795 with piston expander using acetone, R1234yf, and octane as working fluids.
796

797 Organic fluids with very high critical temperature and molecular mass (such as octane), present a
798 low power output for a very different reason to that for fluids with low critical temperature. These
799 fluids, also called ‘very dry’, are characterised by a small enthalpy drop in expansion (see Figure 6
800 (c)) resulting in high temperature at the expander outlet. This leads to high exergy losses in the
801 condenser since the condensing temperature is far from the sink temperature. However, this kind
802 of fluids is characterised by the lowest exergy losses in the evaporator (see Figure 7) due to the
803 possibility to reach a higher average temperature during the heating phase. In general, in this case
804 the pinch point is located at the preheater inlet, as shown in Figure 7.
805

806 Considering the above results, it appears that the best fluid is a compromise between exergy losses
807 in the condenser and in the evaporator. Figure 8 provides the exergy losses in these two components
808 and their sum, for each fluid. Acetone and ethanol, as previously seen, are the best ones, which is
809 confirmed by the minimum overall losses in the heat exchangers. The exergy losses in the expander
810 and in the pump are not displayed since they are of lesser magnitude.
811

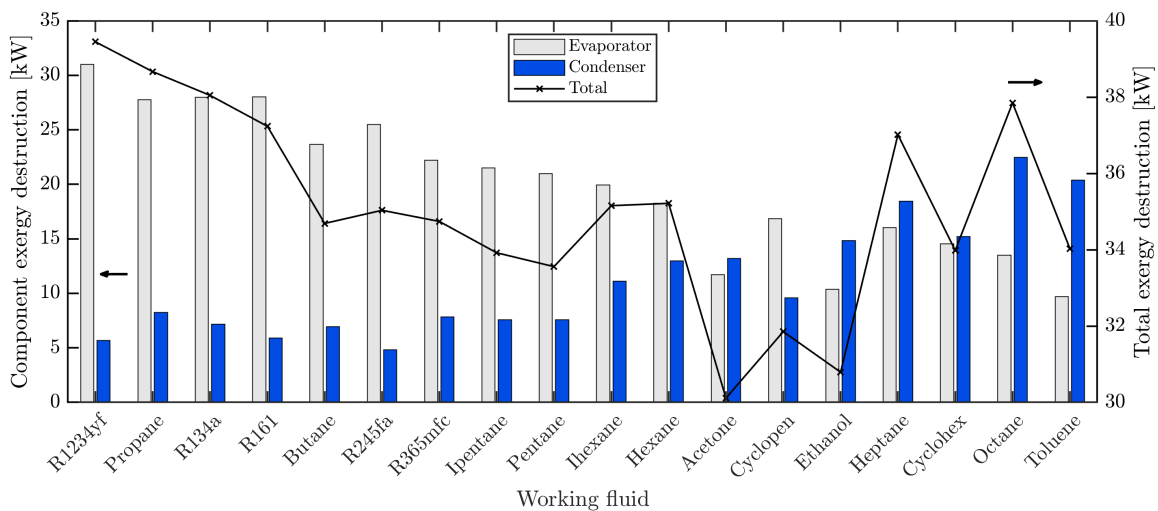

812
813 **Figure 8:** Exergy losses in the evaporator and in the condenser and their sum, for an ORC engine
814 optimised for maximum net power.
815

816 **5.2 Thermoeconomic optimisation**

817

818 In this case, the objective function to be minimised is the turnkey specific investment cost:

819

$$C_s = \frac{C_{PB}}{\dot{W}_{net}}. \quad (55)$$

820 where C_{PB} is the power-block cost (see Table 9 for the detailed definition).

821

822 The same optimisation variables and constraints described in the previous section are employed
 823 for the thermoeconomic optimisation. Particular attention is paid to the design and cost analysis of
 824 the heat exchangers. The optimisation procedure is iterative: a first estimate of the diameters of the
 825 heat exchangers is provided (with nominal sizes); at the end of the optimisation cycle, a check on
 826 the velocity of the fluid through the tubes is performed; if the velocity does not satisfy the
 827 thresholds limits (< 1.5 m/s for liquids and < 30 m/s for vapour) the diameters are increased and a
 828 new optimisation cycle is started. The iterative procedure is repeated until the constraints on the
 829 fluid velocity are satisfied.

829

830 When minimising the specific investment cost (as reported in Table 8) with acetone as working
 831 fluid, the two-stage screw expander is found to give significantly greater net power output
 832 (14.2 kW) compared to either the piston expander (10.5 kW) or the single-stage screw expander
 833 (10.1 kW). This is because of the higher overall pressure ratio of 12.8 which can be achieved by
 834 two screw expanders in series. The single-stage piston expander operates at a higher pressure ratio
 835 of 9.5 relative to the single-stage screw expander, which operates at a pressure ratio of 7.2.

836

837 **Table 8:** Thermodynamic parameters of the ORC system with acetone as working fluid as resulting
 838 from: (i) the maximum power; and (ii) minimum specific investment cost optimisation.

	Screw expander		Piston expander		Two-stage screw expander	
	Opt. max power	Opt. min. spec. cost.	Opt. max power	Opt. min. spec. cost.	Opt. max power	Opt. min. spec. cost.
C_s (Eur/kW)	3130	2370	2430	1630	2190	1990
\dot{W}_{net} (kW)	10.9	10.1	14.3	10.5	17.7	14.2
p_{evap} (bar)	8.0	29.0	24.9	44.6	44.6	44.6
p_{cond} (bar)	1.01	4.00	1.13	4.71	1.01	3.50
\dot{m}_{wf} (kg/s)	0.13	0.12	0.12	0.09	0.10	0.12
d_{sh}	0.29	0.38	0.26	1.00	0.56	0.45
η_{th}	0.11	0.11	0.15	0.11	0.18	0.15
η_{ex}	0.22	0.21	0.29	0.22	0.36	0.29

839

840 In order to compare the results from both thermodynamic and thermoeconomic optimisations,
 841 Table 8 provides the specific costs and main thermodynamic parameters for the ORC engine using
 842 acetone and the three expander configurations. The ORC engine designs identified by the two
 843 optimisations differ quite strongly. For the system with a single-stage screw expander, switching
 844 from thermodynamic to thermoeconomic optimisation reduces the specific cost by 24.7%, while it
 845 falls by only by 8.7% for the two-stage expander. As the expander is the most expensive
 846 component, the thermoeconomic optimisation leads to increases in both the condensing and
 847 evaporating pressures, which reduce the volumetric flow rate and consequently the expander cost.
 848 For this reason, the single-stage expander has a larger margin of improvement in comparison to the
 849 two-stage one. Moreover, the average temperature of the heating phase is increased. Consequently,
 850 the thermoeconomic optimisation produces only a slight reduction in the power output, but a

851 significant reduction in the investment cost. In most cases, the increase of the power output from
 852 moving from a single-stage to a two-stage expander is sufficient to overcome the increase in
 853 investment cost, leading to a more cost-effective system overall, as shown in Figure 9. Fluids with
 854 very low critical temperatures (propane, octane, R1234yf, R161 and R134a) are the exception for
 855 the same reasons as previously explained. In fact, for these fluids, the optimal cycle parameters
 856 remain largely unchanged and the slight increase of the power output is not sufficient to
 857 compensate for the additional cost of the second expander stage.

860 Table 8 shows that, for the case of acetone, the piston expander represents the solution with the
 861 minimum specific cost. Both evaporating and condensing pressures are increased with respect to
 862 the maximum power optimisation results; this leads to a reduction of the mass flow rate and of the
 863 expansion ratio. As a consequence, both the power output and the investment cost decrease, with
 864 a stronger reduction in the latter leading to a lower specific investment cost. Similar behaviour is
 865 obtained for most of the considered fluids, as demonstrated by the specific costs reported in Table
 866 8. The exceptions are fluids such as octane, heptane, toluene, R245fa, R365mfc, and R1234vf,
 867 which have low critical pressures that restrict the scope for higher pressure operation. The most
 868 suitable fluids for the considered application are found to be acetone and ethanol in conjunction
 869 with a piston expander.

870

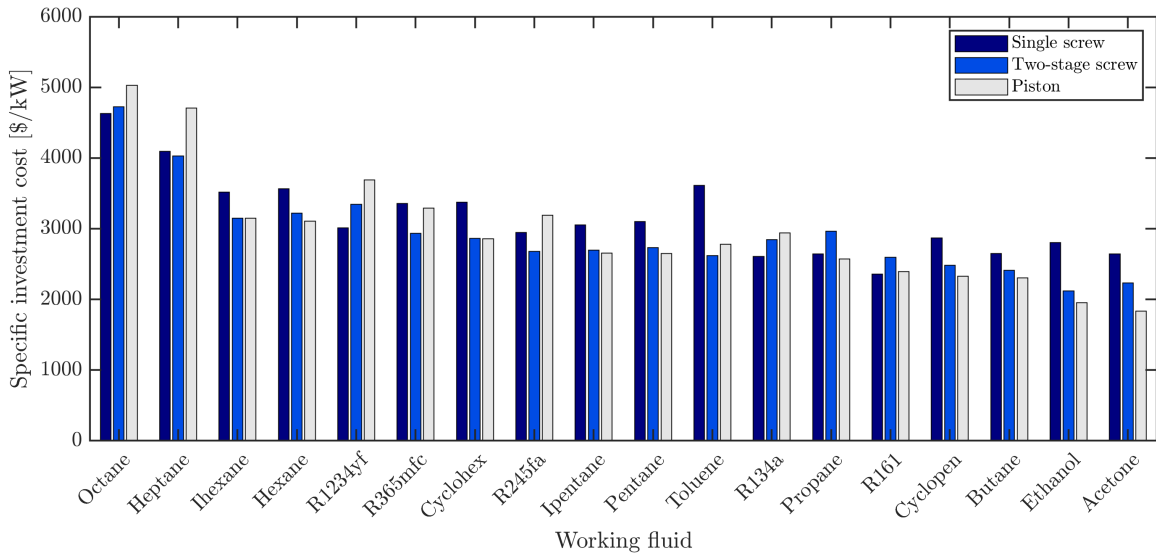

871
 872 **Figure 9:** Comparison of specific investment costs for different working fluids. Specific cost-
 873 minimisation ORC engine optimisation.

874

875 Figure 10 provides the distribution of exergy losses for three systems optimised with a piston
 876 expander, with acetone, R1234yf, and octane, respectively. High critical-temperature fluids like
 877 octane are shown to be unsuitable for multiple reasons. Much of the potential for useful work
 878 contained in the exhaust gases is destroyed since the condensing temperature is very high, inducing
 879 excessive exergy losses in the condenser. R1234yf, as discussed in the previous section, shows the
 880 opposite problem, with high losses in the evaporator as a consequence of the low critical
 881 temperature. It is noteworthy that the distributions of exergy losses obtained for R1234yf and
 882 octane with the present thermoeconomic optimisation, under the considered constraints, are very
 883 similar to those obtained with the previous thermodynamic optimisation, as shown in Figure 7, as
 884 the cycles are heavily constrained. For acetone, the shift to higher evaporating and condensing

885
886
887

pressures means that the system optimised for minimum cost shows higher exergy losses in the condenser than are seen in the system optimised for maximum power.

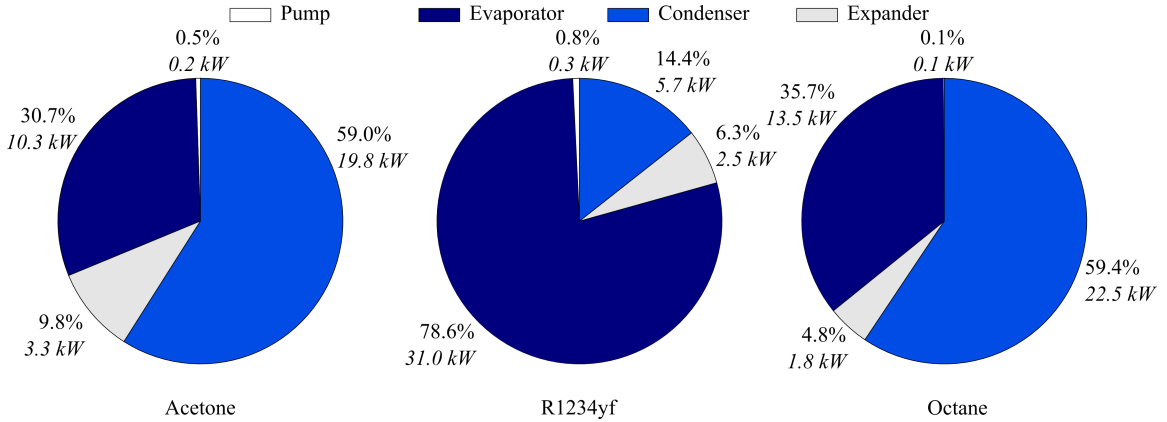

888
889
890
891

Figure 10: Distribution of exergy losses for the cycle with piston expander using acetone, R1234yf, and octane as working fluid, after thermoeconomic optimisation.

892 6. Economic analysis

893 This section provides a techno-economic feasibility assessment of the bottoming ORC system,
894 using acetone as the working fluid. Piston and screw expanders, and the minimum-cost versus
895 maximum-power scenarios are compared. The cost assessment of the ORC engine is based on
896 operation and maintenance costs from the literature. The investment profitability is evaluated by
897 means of the net present value (NPV) and the internal rate of return (IRR), while the levelised cost
898 of energy (LCOE) is calculated to allow comparisons of the electricity generation costs with other
899 technologies. The sensitivity of the economic indices to the electricity selling price (or avoided
900 purchase cost in case of onsite consumption) and the alternative use of the available heat from the
901 ICE for cogeneration is assessed. The profitability of the bottoming ORC engine is strongly
902 influenced by the electricity selling price and by the alternative option to use the waste heat from
903 the ICE to match onsite heat demand. As highlighted in Refs. [27,47], a fair evaluation of the
904 profitability of ORC-based WHR systems at the premises of end users should take into account the
905 energy demand profile and the cost of energy supply. The purpose of this sensitivity analysis is to
906 establish the conditions of heat-demand intensity, costs of heat supply and avoided cost of
907 electricity, under which such a bottoming ORC system becomes profitable.

908

909 6.1 Economic model

910

911 The power-block cost C_{PB} assumed in this analysis includes the cost of site preparation and the cost
912 of service facilities in addition to the purchased equipment cost. Table 9 provides a summary of
913 the cost components to estimate the total investment cost (adapted from Seider et al. [42]).

914

915

Table 9: Components of total investment cost.

Power-block cost, C_{PB}	$C_{PB} = \sum_{i \in \text{Components}} C_i$
Cost of site preparation, C_{site}	$C_{site} = 0.04 \cdot C_{PB}$
Cost of service facilities, C_{serv}	$C_{serv} = 0.04 \cdot C_{PB}$
Total direct permanent investment, C_{DPI}	$C_{DPI} = C_{PB} + C_{site} + C_{serv}$
Cost of contingencies and contractors' fees, C_{cont}	$C_{cont} = 0.10 \cdot C_{DPI}$

Cost of land, C_{land}	$C_{land} = 0$
Cost of royalties, C_{royal}	$C_{royal} = 0$
Cost of plant startup, $C_{startup}$	$C_{startup} = 0.10 \cdot C_{DPI}$
Total investment cost, C_{TCI}	$C_{TCI} = C_{DPI} + C_{land} + C_{royal} + C_{startup}$

916
917
918
919
920
921
922
923
924
925
926
927
928
929
930
931
932
933
934

The power-block cost C_{PB} , is calculated via the component-cost equations listed in Section 3. Contingency costs and contractors' fees incurred during the construction of the system are set to 10% of the direct permanent investment, C_{DPI} . The cost of the land, C_{land} , is set to zero, under the assumption that the bottoming ORC system is being integrated into an existing CHP facility. The cost of royalties is also set to zero. Assuming the generated power from the ORC system is used to meet the local electricity demand, the annual income corresponds to the reduction of the end user's energy bill.

Mean electricity prices for industrial consumers in European countries from 2014 to 2016, shown in Figure 11, are used to define a suitable range of electricity prices for a sensitivity analysis of the economic viability. The lowest limit of 0.06 €/kWh is representative of countries such as Bulgaria, Finland and Sweden, while the upper limit of 0.18 €/kWh is representative of countries with high electricity prices, such as Cyprus, Germany, Italy, Malta and the United Kingdom. It should be noted that the electricity price is the relevant benchmark only where any onsite generation, such as a gas-fired ICE, is unable to increase output further to meet the demand for electricity; otherwise the comparison should be made against the cost of additional gas consumed to run the ICE at higher output.

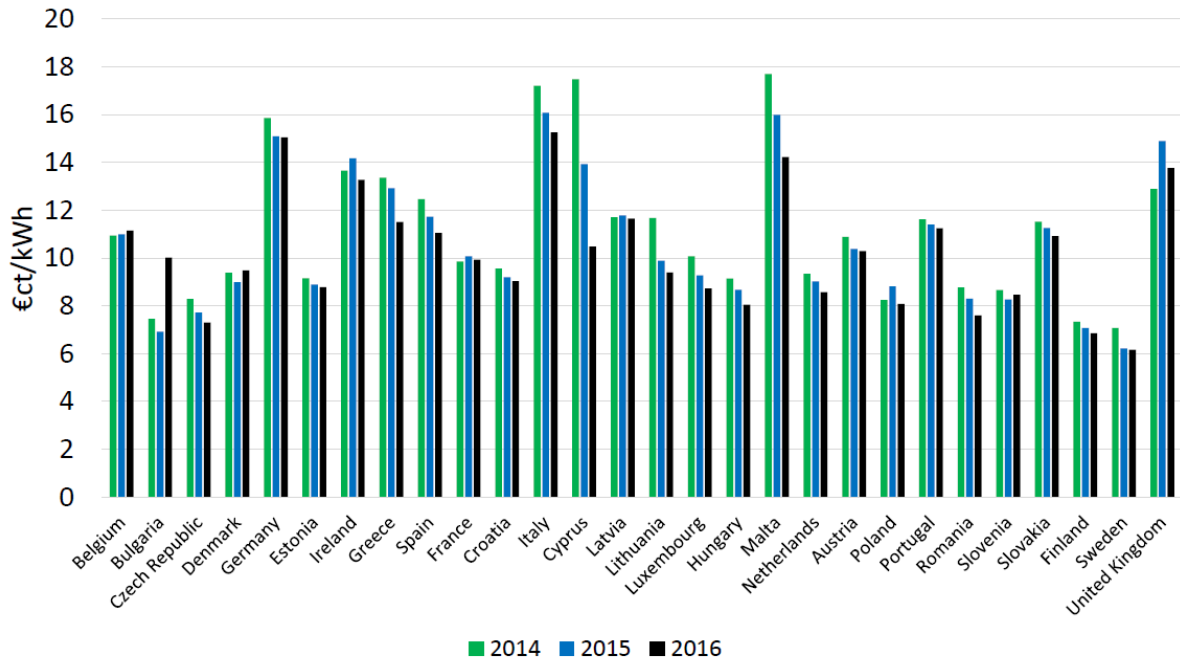

935
936
937
938
939
940
941

Figure 11: Electricity prices for industrial consumers in European countries 2014-2016 [48].

The financial parameters for the calculation of the economic indices are reported in Table 10. The operation and maintenance costs and the insurance costs are set to 5% and 0.3% of the C_{TCI} .

942

Table 10: Assumptions used in the financial model.

Plant lifetime	20 years
Load factor, f_{load}	0.90 (7884 h/year)
System degradation rate, f_{degr}	1.0%
Cost of capital, c_c	5.0%
Inflation rate, r_i	2.0%
Nominal discount rate, $k = (1 + c_c) \cdot (1 + r_i)$	7.1%
Inflation rate of electricity price, e	2.0%

943

944

945

946

947

948

949

950

The annual income from electricity production of the ORC system assumes a full-load capacity factor of 90% (i.e., 7884 operating h/year), which is representative of a CHP engine in baseload operation. The annual energy production is calculated assuming the installed power from Table 8 for the different expanders and objective functions. The following economic indices are evaluated:

Net present value (NPV):

$$\begin{aligned}
 NPV &= \sum_{i=1}^N \frac{CF_i}{(1+k)^i} - C_{TCl} \\
 &= \sum_{i=1}^N \left[\frac{AEP_0 \cdot (1 - f_{degr})^i \cdot C_{elect}(1+e)^i - C_{annual,i}}{(1+k)^i} \right] - C_{TCl}, \quad (56)
 \end{aligned}$$

951

952

953

954

955

956

957

958

959

where AEP_0 represents the annual electricity production in the first year, i is the time period (year), and N the plant lifetime (20 years). CF_i , the net cash flow for year i , considers the net cash flow derived from the electricity savings minus the annual costs, sum of operation, maintenance and insurance costs. C_{elect} represents the electricity avoided cost or selling price, and $C_{annual,i}$ is the operation and maintenance annual cost.

Levelised cost of electricity (LCOE):

960

961

962

963

The LCOE is the cost incurred to generate a given amount of electricity, including operational and annualised investment costs. In the proposed application, it represents the minimum electricity supply cost to secure the investment profitability, and is defined as follows:

$$LCOE = \frac{C_{TPI} + \sum_{i=1}^N C_{annual,i}}{\sum_{i=1}^N \frac{AEP_0 \cdot (1 - f_{degr})^i}{(1+k)^i}} \quad (57)$$

964

965

966

967

968

969

970

971

972

973

In Eq. (57), the annual operating costs, $C_{annual,i}$, are kept constant during the system lifetime and not discounted, while the electricity generation is discounted [49]. The rationale is that the energy generated corresponds to the earnings from the sale of this energy.

6.2 Economic findings

Assuming acetone as the working fluid, and considering two objective functions (maximum power and minimum specific cost), the six system configurations of Table 8 are obtained. The

974 corresponding total investment costs are calculated on the basis of the cost factors of Table 9.
 975 Figure 12 reports the LCOE for these scenarios, and Figure 13 reports the NPV and IRR when
 976 varying the electricity avoided cost in the range 0.07 – 0.19 €/kWh.
 977

978 In particular, Figure 12 shows the levelised cost of electricity (LCOE) as a function of the lifetime
 979 (neglecting repowering costs). The gradient of the LCOE curve flattens over time, and the LCOE at
 980 15 years approaches that at 20 years of lifetime. As expected, the cost minimisation strategy
 981 produces a lower LCOE relative to the maximum power optimisation. Moreover, the piston
 982 expander presents lower LCOE in comparison to the screw expander when the minimum cost
 983 strategy is considered, due to its lower investment cost. However, if the optimisation is carried out
 984 to maximise power, the two-stage screw expander offers the lowest LCOE, due to its higher
 985 conversion efficiency.
 986

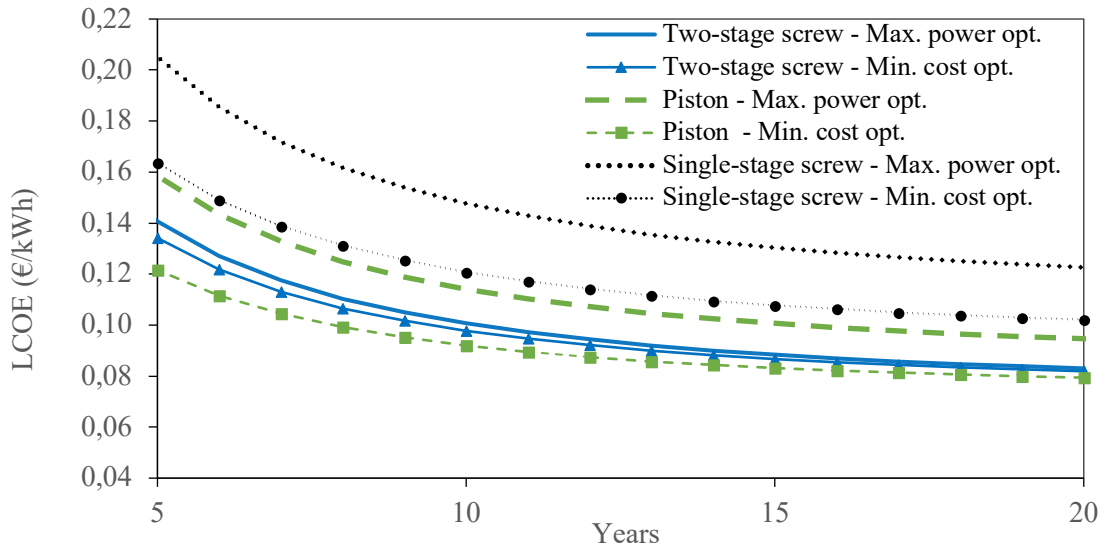

987 **Figure 12:** Variation of LCOE over the lifetime with acetone as working fluid and for a power-
 988 only scenario (i.e., no heat demand). Results are reported for the two objective functions:
 989 maximising net power and minimising specific investment cost.
 990

991 Figure 13 shows discounted payback times (PBT) ranging between a minimum value of 2 years
 992 (piston expander optimised for minimum investment cost in the high electricity-value scenario), to
 993 values beyond the investment lifetime (negative NPV), (i.e. single-stage screw expander optimised
 994 for maximum power in the low electricity value scenario). The annual cash flow remains relatively
 995 constant over time because the degradation rate of the system and the rate of inflation of the
 996 electricity price are of comparable magnitude.
 997

998 These results indicate that the most influential factor in the profitability of WHR via small-scale
 999 ORC systems is the value of produced electricity. In particular, ORC systems already appear to be
 1000 economically viable for countries where the industrial electricity price is above 0.13 \$/kWh such
 1001 as Italy, Germany and United Kingdom. In contrast, for countries with low electricity prices such
 1002 as Sweden, Finland and Bulgaria are unlikely to be considered economically viable. In the high
 1003 electricity value scenario, the two-stage screw expander optimised for maximum power offers the
 1004 highest NPV; however, this is not reflected on the IRR, which is highest when selecting the piston
 1005 expander optimised for minimum cost, due to the reduced capital cost. At low electricity prices,
 1006 the cheapest option of the piston expander with minimum cost optimisation delivers both the
 1007

.008
.009
.010

highest NPV and the highest IRR and, due to its lower investment cost, and it also offers the best pay-back times throughout the range of electricity selling prices.

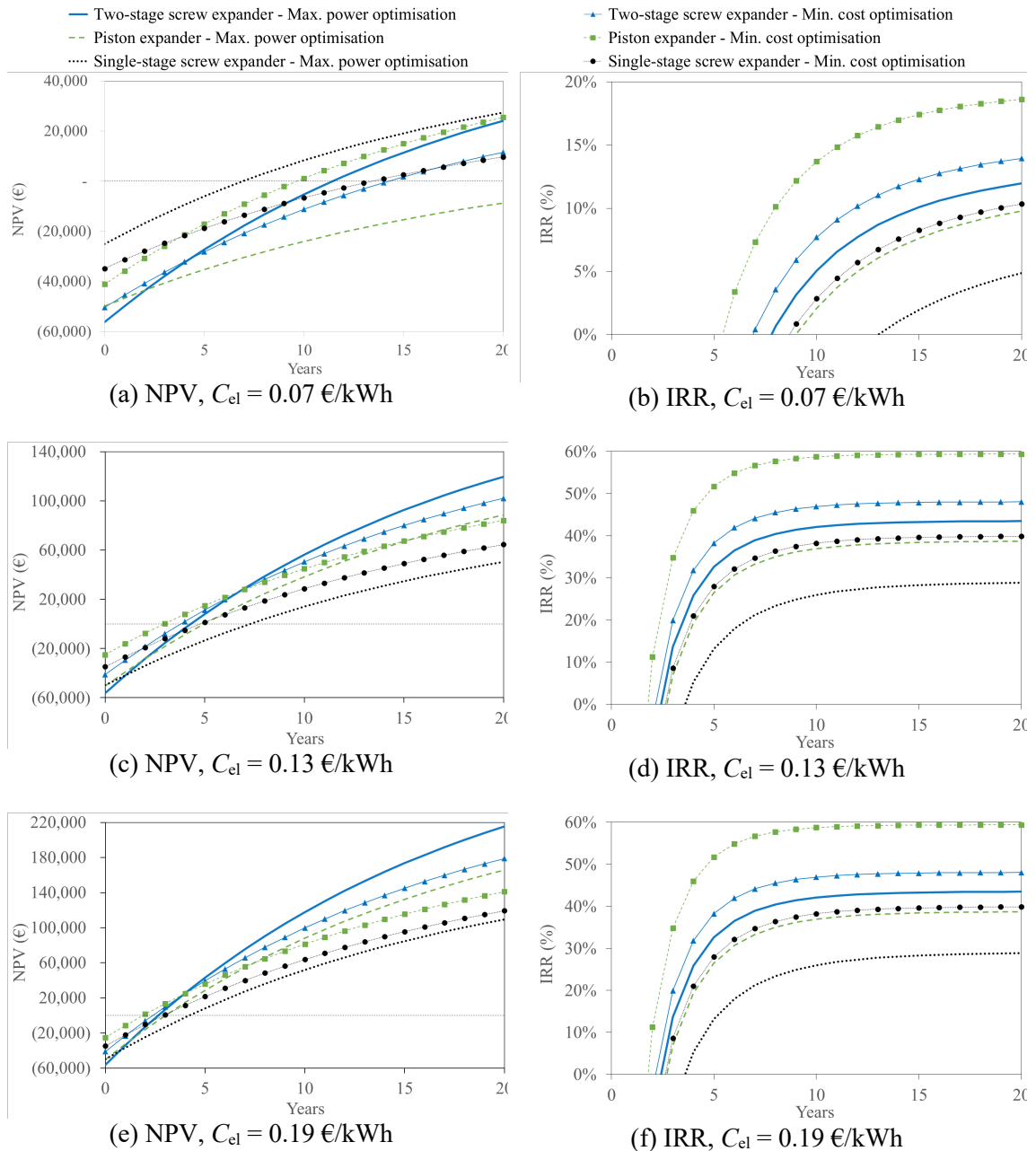

.011
.012
.013
.014
.015
.016
.017
.018

Figure 13: Variation of NPV and IRR over a 20-year plant life for a power-only scenario (i.e., no heat demand) for a range of avoided electricity costs (C_{el}). Systems with reciprocating-piston, single- and two-stage screw expanders are optimised for maximum net power output and minimum specific investment cost in turn.

One of the main barriers when installing bottoming ORC engines coupled to internal combustion engines for decentralised generation is the competing use of such heat to match onsite heating demand at medium-high temperature. This is because the ORC engine discharges heat from the

019 condenser at low temperature, not compatible with the temperature of the heat demand. The two
 020 available alternatives are to switch on/off the ORC engine, on the basis of the heat demand profile,
 021 or install an additional heating system to cover the demand. The option to vary the condensing
 022 temperature of the ORC engine in order to match the variable heating demand of the load has also
 023 been explored by some manufacturers, while the trade-off between condensing temperature and
 024 electrical efficiency has been investigated in the literature, in order to maximise the global energy
 025 efficiency of the system (thermal and electrical) [50].

026
 027 The influence of heat demand on the LCOE and NPV of the ORC system is illustrated in Figures
 028 14 and 15, considering the ORC system to be operating as baseload, and incurring additional costs
 029 for natural gas consumption to match the heating demand when required. These costs are
 030 incorporated as operating costs of the ORC generator, to allow for a fair comparison of the
 031 profitability of such waste-heat recovery system with or without the presence of onsite heat demand.
 032 As can be seen from Figure 14, the LCOE for the minimum cost system with a piston expander
 033 increases from 0.05 €/kWh_e (no heat demand) to 0.07 and 0.08 €/kWh_e respectively for the scenario
 034 of 30% and 50% heat-demand intensity.
 035

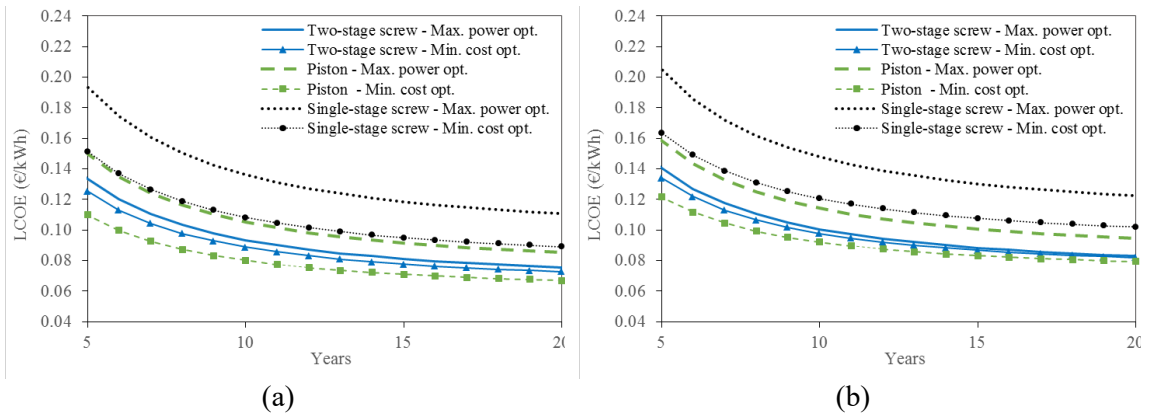

036 **Figure 14.** Variation of LCOE over the lifetime assuming heat demand respectively of: (a) 30%,
 037 and (b) 50% of the bottoming ORC engine operating time, at a heating cost of 0.03 €/kWh, for the
 038 six expander and optimisation scenarios, and acetone as the working fluid.
 039

040 The effect on the project economics of burning natural gas to replace heat supplied to the ORC
 041 engine can be seen clearly in Figure 15. At low avoided electricity costs, the payback time is seen
 042 to lengthen substantially for the case of 30% heat demand, and almost all of the systems fail to
 043 achieve a positive NPV in the 50% heat demand case. Depending on the profile of heat demand, it
 044 is likely that turning the ORC off when heat is required locally would be preferable, though the
 045 project economics for the ORC would still be negatively affected.
 046

047 For higher avoided electricity costs, it becomes more feasible to cover the cost of natural gas
 048 consumption through savings associated with the ORC electricity generation, though this does not
 049 offset the associated emissions. The shortest payback time of 2 – 4 years is achieved with the piston
 050 expander system optimised for minimum cost, for avoided costs of electricity of 0.19 – 0.13 €/kWh,
 051 respectively. The system with a two-stage screw expander optimised for maximum power remains
 052 the most profitable over the project lifetime.
 053

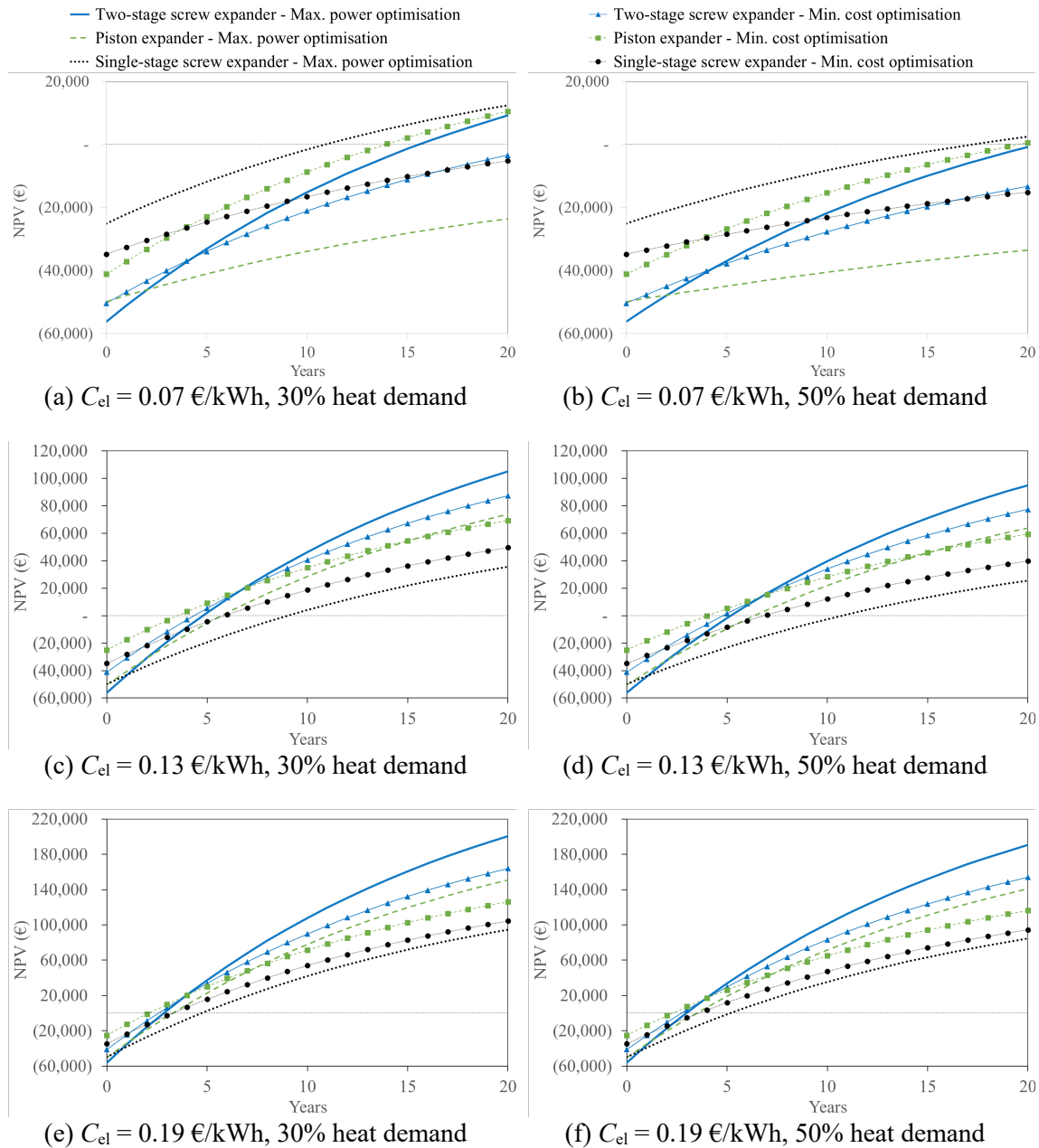

054
055
056
057
058
059
060
061
062
063
064
065

Figure 15: Variation of NPV over a 20-year plant lifetime for heat demand of 30% and 50% of the bottoming ORC engine operating time at a heating cost of 0.03 €/kWh, for a range of avoided electricity costs (C_{el}) between 0.07 and 0.19 €/kWh. Systems with reciprocating-piston, single- and two-stage screw expanders are optimised for maximum net power output and minimum specific investment cost in turn.

7. Conclusions

This research proposed a thermodynamic and thermoeconomic optimisation of small-scale ORC systems recovering heat from the exhaust gases of a 185-kW natural-gas reciprocating internal combustion engine operating in baseload mode. A single-stage screw expander, a two-stage screw

066 expander and a single-stage piston expander were compared, along with a selection of 18 working
067 fluids. Since the cost of ORC systems is of primary importance in enabling the uptake of this
068 technology, economic considerations were of particular interest.

069
070 The results of the thermodynamic optimization process show that the correct choice of the fluid
071 properties for each ORC application is fundamental to achieve high performance. The results
072 indicate that, in general, for cycles with a relatively high temperature difference between the hot
073 and cold streams (in the present case it can reach about 500 °C), fluids with high or low critical
074 temperature are not suitable. The former fluids increase the exergy losses at the condenser and the
075 latter at the evaporator. Fluids with intermediate critical temperature, such as acetone and ethanol,
076 provide optimal results.

077
078 Furthermore, in presence of high-temperature heat source, two-stage screw expanders achieve a
079 higher expansion pressure ratio than the single-stage machine without sacrificing efficiency,
080 enabling an improved temperature match, and thus tending to deliver the highest power. The results
081 also show that the single-stage piston expander allows a higher expansion ratio than the single-stage
082 screw expander and enables a higher power output for fluids well-suited to the heat-source
083 temperature range. This appears to be a very good characteristic of piston expanders.

084
085 In the thermoeconomic optimisation of the ORC system, the expander was found to be the most
086 expensive component, with a cost that varies with its volumetric flow rate. In most cases, the
087 increase of the power output from using a two-stage screw expander rather than a single-stage
088 screw was sufficient to outweigh the greater investment cost, leading to lower specific investment
089 costs, except for fluids with a low critical temperature which did not benefit from the greater
090 pressure ratio capabilities of the two-stage expander.

091
092 For most of the fluids considered, the piston expander presented the lowest specific investment
093 cost. Since piston expanders are not as mature as screw machines, especially at these scales, this
094 motivates further consideration of this component. The preferred fluids for minimum cost were
095 acetone and ethanol, thanks to their good thermal match to the high-temperature heat source.

096
097 Finally, financial appraisals of the ORC investment reported payback times as low as 2 – 3 years
098 when the value of the electricity produced was above 0.13 €/kWh, which is a promising outcome
099 as this is approximately the same of a stationary cogenerating ICE project. An ORC engine
100 optimised for maximum power with a two-stage screw expander gave the highest net present value,
101 which was appropriate when the electricity value was high enough to reward the increased
102 conversion efficiency of this more expensive technical solution. The influence of the onsite heating
103 demand was also explored, in light of the fact that the heat source may be used to match onsite heat
104 demand. In this case, the adoption of a standard ORC system reduced the availability of such heat
105 for other uses, and the investment profitability was consequently reduced.

106
107 The results of the proposed thermo-economic optimization and related sensitivity analysis allow
108 quantifying the key techno-economic factors influencing the profitability of the bottoming ORC
109 system to recover waste heat from the gas fired CHP engine, which could be useful for both energy
110 operators aiming at maximizing the energy performance of specific industrial processes, and
111 policymakers that have to set up the most effective support mechanisms for energy efficiency.

112
113 **Acknowledgements**

114
115 This work was supported by the UK Engineering and Physical Sciences Research Council (EPSRC)
116 [grant number EP/P004709/1]. A short version of this paper was presented at the 4th Annual Engine
117 ORC Consortium (EORCC) Workshop for the Automotive and Stationary Industries, 15-17
118 November 2017, Detroit. This paper is a substantial extension of the short version of the conference
119 paper. Data supporting this publication can be obtained on request from cep-lab@imperial.ac.uk.
120

121 **References**

122

- 123 [1] Amirante R, Cassone E, Distaso E, Tamburrano P. Overview on recent developments in
124 energy storage: Mechanical, electrochemical and hydrogen technologies. *Energy Convers*
125 *Manag* 2017;132:372–87.
- 126 [2] Markides CN. The role of pumped and waste heat technologies in a high-efficiency
127 sustainable energy future for the UK. *Appl Therm Eng* 2013;53:197–209.
128 doi:10.1016/j.applthermaleng.2012.02.037.
- 129 [3] Tartièrè T, Astolfi M. A world overview of the organic Rankine cycle market. *Energy*
130 *Procedia* 2017;129:2–9.
- 131 [4] Pantaleo AM, Camporeale SM, Shah N. Thermo-economic assessment of externally fired
132 micro-gas turbine fired by natural gas and biomass: Applications in Italy. *Energy Convers*
133 *Manag* 2013;75:202–13.
- 134 [5] Pantaleo AM, Giarola S, Bauen A, Shah N. Integration of biomass into urban energy systems
135 for heat and power. Part II: Sensitivity assessment of main techno-economic factors. *Energy*
136 *Convers Manag* 2014;83:362–76.
- 137 [6] Amirante R, De Palma P, Distaso E, Pantaleo AM, Tamburrano P. Thermodynamic analysis
138 of a small scale combined cycle for energy generation from carbon neutral biomass. *Energy*
139 *Procedia* 2017;129:891–8. doi:10.1016/j.egypro.2017.09.213.
- 140 [7] Camporeale SM, Ciliberti PD, Fortunato B, Torresi M, Pantaleo AM. Externally fired micro
141 gas turbine and ORC bottoming cycle: optimal biomass/natural gas CHP configuration for
142 residential energy demand. *ASME Turbo Expo 2015 Turbine Tech. Conf. Expo.*, 2015.
- 143 [8] Amirante R, De Palma P, Distaso E, Tamburrano P. Thermodynamic analysis of small-scale
144 externally fired gas turbines and combined cycles using turbo-compound components for
145 energy generation from solid biomass. *Energy Convers Manag* 2018;166.
146 doi:10.1016/j.enconman.2018.04.055.
- 147 [9] Pantaleo AM, Camporeale SM, Miliozzi A, Russo V, Shah N, Markides CN. Novel hybrid
148 CSP-biomass CHP for flexible generation: Thermo-economic analysis and profitability
149 assessment. *Appl Energy* 2017;204:994–1006.
- 150 [10] Pantaleo AM, Camporeale SM, Sorrentino A, Miliozzi A, Shah N, Markides CN. Hybrid
151 solar-biomass combined Brayton/organic Rankine-cycle plants integrated with thermal
152 storage: Techno-economic feasibility in selected Mediterranean areas. *Renew Energy* 2018.
153 doi:10.1016/j.renene.2018.08.022.
- 154 [11] Quoilin S, Declaye S, Tchanche BF, Lemort V. Thermo-economic optimization of waste heat
155 recovery Organic Rankine Cycles. *Appl Therm Eng* 2011;31:2885–93.
156 doi:10.1016/j.applthermaleng.2011.05.014.
- 157 [12] Chang J-C, Hung T-C, He Y-L, Zhang W. Experimental study on low-temperature organic
158 Rankine cycle utilizing scroll type expander. *Appl Energy* 2015;155:150–9.
- 159 [13] Li T, Zhang Z, Lu J, Yang J, Hu Y. Two-stage evaporation strategy to improve system
160 performance for organic Rankine cycle. *Appl Energy* 2015;150:323–34.
- 161 [14] Benato A, Macor A. Biogas engine waste heat recovery using organic Rankine cycle. *Energies*
162 2017;10:1–18. doi:10.3390/en10030327.
- 163 [15] Chatzopoulou MA, Markides CN. Thermodynamic optimisation of a high-electrical efficiency
164 integrated internal combustion engine – Organic Rankine cycle combined heat and power

- 165 system. *Appl Energy* 2018;226:1229–51. doi:10.1016/j.apenergy.2018.06.022.
- 166 [16] Imran M, Usman M, Park B-S, Lee D-H. Volumetric expanders for low grade heat and waste
167 heat recovery applications. *Renew Sustain Energy Rev* 2016;57:1090–109.
168 doi:10.1016/j.rser.2015.12.139.
- 169 [17] Hsu S-W, Chiang H-W, Yen C-W, Hsu S-W, Chiang H-W, Yen C-W. Experimental
170 investigation of the performance of a hermetic screw-expander organic Rankine cycle.
171 *Energies* 2014;7:6172–85. doi:10.3390/en7096172.
- 172 [18] Dumont O, Parthoens A, Dickes R, Lemort V. Experimental investigation and optimal
173 performance assessment of four volumetric expanders (scroll, screw, piston and roots) tested
174 in a small-scale organic Rankine cycle system. *Energy* 2018.
175 doi:10.1016/j.energy.2018.06.182.
- 176 [19] Qiu G, Liu H, Riffat S. Expanders for micro-CHP systems with organic Rankine cycle. *Appl
177 Therm Eng* 2011;31:3301–7.
- 178 [20] Bao J, Zhao L. A review of working fluid and expander selections for organic Rankine cycle.
179 *Renew Sustain Energy Rev* 2013;24:325–42. doi:10.1016/j.rser.2013.03.040.
- 180 [21] Saghatoun S, Zhuge W, Zhang Y. Review of expander selection for small-scale organic
181 Rankine cycle. ASME 4th Jt. US-European Fluids Eng. Div. Summer Meet. collocated with
182 ASME 12th Int. Conf. Nanochannels, Microchannels, Minichannels, 2014.
- 183 [22] Weiß AP. Volumetric expander versus turbine--which is the better choice for small ORC
184 plants. 3rd Int. Semin. ORC Power Syst., 2015, p. 12–4.
- 185 [23] Song P, Wei M, Shi L, Danish SN, Ma C. A review of scroll expanders for organic Rankine
186 cycle systems. *Appl Therm Eng* 2015;75:54–64.
- 187 [24] Ziviani D, Gusev S, Lecompte S, Groll EA, Braun JE, Horton WT, et al. Characterizing the
188 performance of a single-screw expander in a small-scale organic Rankine cycle for waste heat
189 recovery. *Appl Energy* 2016;181:155–70. doi:10.1016/j.apenergy.2016.08.048.
- 190 [25] Glavatskaya Y, Podevin P, Lemort V, Shonda O, Descombes G. Reciprocating expander for
191 an exhaust heat recovery Rankine cycle for a passenger car application. *Energies*
192 2012;5:1751–65. doi:10.3390/en5061751.
- 193 [26] Taleb AI, Sapin P, Barfuß C, Fabris D, Markides CN. CFD analysis of thermally induced
194 thermodynamic losses in the reciprocating compression and expansion of real gases. *Int Semin
195 Non-Ideal Compressible-Fluid Dyn Propuls Power* 2017;821. doi:10.1088/1742-
196 6596/755/1/011001.
- 197 [27] Oyewunmi OA, Kirmse CJW, Pantaleo AM, Markides CN. Performance of working-fluid
198 mixtures in ORC-CHP systems for different heat-demand segments and heat-recovery
199 temperature levels. *Energy Convers Manag* 2017;148:1508–24.
200 doi:10.1016/j.enconman.2017.05.078.
- 201 [28] White MT, Oyewunmi OA, Haslam AJ, Markides CN. Industrial waste-heat recovery through
202 integrated computer-aided working-fluid and ORC system optimisation using SAFT- γ Mie.
203 *Energy Convers Manag* 2017;150:851–69.
- 204 [29] White MT, Oyewunmi OA, Chatzopoulou MA, Pantaleo AM, Haslam AJ, Markides CN.
205 Computer-aided working-fluid design, thermodynamic optimisation and thermoeconomic
206 assessment of ORC systems for waste-heat recovery. *Energy* 2018;161:1181–98.
- 207 [30] Astolfi M. Techno-economic optimization of low temperature CSP systems based on ORC
208 with screw expanders. *Energy Procedia* 2015;69:1100–12. doi:10.1016/j.egypro.2015.03.220.
- 209 [31] Sapin P, Simpson M, White AJ, Markides CN. Lumped dynamic analysis and design of a
210 high-performance reciprocating-piston expander. 30th Int. Conf. Effic. Cost, Optim. Simul.
211 Environ. Impact Energy Syst. ECOS 2017, 2017.
- 212 [32] Lemmon EW, Huber ML, McLinden MO. NIST Standard Reference Database 23: Reference
213 Fluid Thermodynamic and Transport Properties-REFPROP, Version 9.1, National Institute of
214 Standards and Technology, Standard Reference Data Program, Gaithersburg 2013.
- 215 [33] Shu G, Li X, Tian H, Liang X, Wei H, Wang X. Alkanes as working fluids for high-
216 temperature exhaust heat recovery of diesel engine using organic Rankine cycle. *Appl Energy*

- 217 2014;119:204–17.
- 218 [34] Chatzopoulou MA, Simpson M, Sapin P, Markides CN. Off-design optimisation of organic
 219 Rankine cycle (ORC) engines with piston expanders for medium-scale combined heat and
 220 power applications. *Appl Energy* 2019;238:1211–36. doi:10.1016/j.apenergy.2018.12.086.
- 221 [35] Simpson MC, Pantaleo AM, De Palma P, Markides CN. Design and thermo-economic
 222 optimisation of small-scale bottoming ORC systems coupled to biomass CHP gasification
 223 cycles. *Int. Conf. Effic. Cost, Optimisation, Simul. Environ. Impact Energy Syst., Guimarães,*
 224 *Portugal: 2018.*
- 225 [36] Lê V, Kheiri A, Feidt M, Pelloux-Prayer S. Thermodynamic and economic optimizations of a
 226 waste heat to power plant driven by a subcritical ORC (Organic Rankine Cycle) using pure or
 227 zeotropic working fluid. *Energy* 2014;78:622–38.
- 228 [37] Edwards JE. Design and rating shell and tube heat exchangers. P I Des Ltd, Teesside 2008.
- 229 [38] Jung DS, Mclinden M, Radermachert R, Didion D. Horizontal flow boiling heat transfer
 230 experiments with a mixture of R22 / R114. *Int J Heat Mass Transf* 1989;32:131–45.
- 231 [39] Shin JY, Kim MS, Ro ST. Correlation of evaporative heat transfer coefficients for refrigerant
 232 mixtures. *Int Refrig Air Cond Conf* 1996:151–6.
- 233 [40] Oyewunmi OA, Markides CN. Thermo-economic and heat transfer optimization of working-
 234 fluid mixtures in a low-temperature organic Rankine cycle system. *Energies* 2016;9:448.
 235 doi:10.3390/en9060448.
- 236 [41] Perry JH. *Chemical Engineers' Handbook* 1950.
- 237 [42] Seider WD, Seader JD, Lewin DR, Widagdo S. *Product and Process Design Principles:*
 238 *Synthesis, Analysis, and Design, Section 9.3* 2008.
- 239 [43] Loh HP, Lyons J, White C. W. *Process Equipment Cost Estimation: Final Report. Natl Energy*
 240 *Technol Center, DOE/NETL-2002/1169* 2002.
- 241 [44] Bitzer. *Price List 2015.* 2015.
- 242 [45] Panesar AS, Morgan RE, Miché NDD, Heikal MR. Working fluid selection for a subcritical
 243 bottoming cycle applied to a high exhaust gas recirculation engine. *Energy* 2013;60:388–400.
- 244 [46] Bird, R. H., Hribar, M. E. Nocedal J. An interior point algorithm for large-scale nonlinear
 245 programming. *SIAM J Optim* 1999;9:877–900.
- 246 [47] Pantaleo AM, Camporeale S, Shah N. Natural gas-biomass dual fuelled microturbines:
 247 Comparison of operating strategies in the Italian residential sector. *Appl Therm Eng*
 248 2014;71:686–96.
- 249 [48] Tocci L, Pal T, Pasmazoglou I, Franchetti B. Small scale organic Rankine cycle (ORC): A
 250 techno-economic review. *Energies* 2017;10:413.
- 251 [49] Mainali B, Silveira S. Alternative pathways for providing access to electricity in developing
 252 countries. *Renew Energy* 2013;57:299–310. doi:10.1016/j.renene.2013.01.057.
- 253 [50] Pantaleo AM, Camporeale S, Fortunato B. Small scale biomass CHP: techno-economic
 254 performance of steam vs gas turbines with bottoming ORC. *Energy Procedia* 2015;82:825–32.
- 255