



Politecnico  
di Bari

Repository Istituzionale dei Prodotti della Ricerca del Politecnico di Bari

## A Smart Sensor Network for Sea Water Quality Monitoring

This is a post print of the following article

*Original Citation:*

A Smart Sensor Network for Sea Water Quality Monitoring / Adamo, Francesco; Attivissimo, Filippo; GUARNIERI CALO' CARDUCCI, Carlo; Lanzolla, Anna Maria Lucia. - In: IEEE SENSORS JOURNAL. - ISSN 1530-437X. - 15:5(2015), pp. 2514-2522. [10.1109/JSEN.2014.2360816]

*Availability:*

This version is available at <http://hdl.handle.net/11589/771> since: 2021-03-09

*Published version*

DOI:10.1109/JSEN.2014.2360816

Publisher:

*Terms of use:*

(Article begins on next page)

# A Smart Sensor Network for Sea Water Quality Monitoring

Francesco Adamo, Filippo Attivissimo, *Member, IEEE*, Carlo Guarnieri Calò Carducci, and Anna M. L. Lanzolla, *Member, IEEE*

**Abstract** – Measurement of chlorophyll concentration is gaining more and more importance in evaluating the status of the marine ecosystem. For wide-areas monitoring a reliable architecture of wireless sensors network (WSN) is required. In this paper we present a network of smart sensors, based on ISO/IEC/IEEE 21451 suite of standards, for in situ and in continuous space-time monitoring of surface water bodies, in particular for seawater. The system is meant to be an important tool for evaluating water quality and a valid support to strategic decisions concerning critical environment issues. The aim of the proposed system is to capture possible extreme events and to collect long term periods of data.

**Index Terms**—Smart sensor, ISO/IEC/IEEE 21451-2, IEEE 1451.5, Wireless Sensor Networks, Remote control, GPRS VPN

## I. MOTIVATION OF THE WORK

MONITORING and modelling studies are useful and suitable tools for assessing the environmental pollution [1]-[3]. In particular, the sea water quality evaluation is an important issue concerning people's well-being as well as economical activities which depend on it. The growing anthropogenic pressure on marine ecosystem, in terms of both resources exploiting and pollutants discharged in it, make it necessary to develop systems capable of providing real-time measurements and to collect and manage large amounts of data for further analysis.

Usually, many events that can affect seawater quality, occur in narrow time windows making it impossible to intervene promptly using common monitoring campaigns. In fact, instruments involved in sea water quality measurement, like CTD (Conductivity, Temperature and Pressure) probes and other plug in devices, are generally expensive and bulky instruments, not suitable neither designed to be a part of a sensor network. Thus biologists have to perform long manual sampling campaigns aboard of research vessels to get to points of interest. This approach has the advantage to provide high resolution and reliable measurements, also with a vertical profile of the water column under investigation; on the other hand it can only be performed at considerable time intervals,

F. Adamo, F. Attivissimo, C. Guarnieri Calò Carducci and A. M. L. Lanzolla are with Department of Electric and Information Engineering, Polytechnic of Bari, Italy (corresponding author phone: +39.080.5963584; fax: +39.080.5963410; e-mail: [lanzolla@misure.poliba.it](mailto:lanzolla@misure.poliba.it)).

for instance every couple of weeks or months depending mainly on funds availability of the agency responsible of monitoring. It appears obvious at this point, that if an event of interest occurs between two given sampling instants and lasts for some days or weeks, it would leave no trace as if it has never happened and it would be impossible to take the necessary precautions in a timely manner. A case in point occurred along the coasts of Apulia region (Italy) in June 2014, when an early bloom of toxic algae known as *Ostreopsis Vulgate* (in the following simply O.V.), caused illnesses to swimmers, such as rhinitis, pharyngitis, laryngitis, bronchitis, high fever, dermatitis, and conjunctivitis. The damage, also involved food risks due to the accumulation of toxins in the organisms that live on the seabed, such as octopuses and seafood, as well as economic damages to the equipment of ship-owners, whose fishing nets may have been contaminated.

The appearance of O.V. in the seas of Apulia dates back to the early 2000s, hence phenomena connected with it are still new and under study. Its bloom, generally expected in August, is due not only to the abundance of nutrients, but also to favorable climatic conditions, like 10-15 days of calm sea. In this case, the traditional strategy adopted by the agency in charge of data collection, typically performed with a fortnightly basis, but thickened when a maximum of O.V. Concentration is expected, was insufficient for the purpose of prediction of such a phenomenon. Therefore, it is inefficient in inducing preventive policies and not even able to provide new information on the evolution of the phenomenon itself.

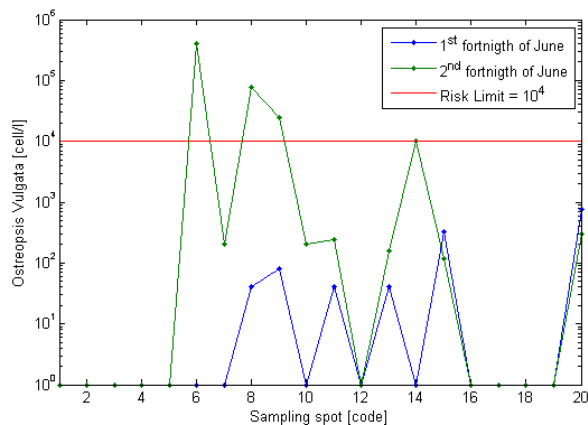

Fig. 1. *Ostreopsis Vulgate* micro-algae concentration in the water column [4]

Fig. 1 shows how the lack of a suitable time interval between the two series have completely masked the emergence of the bloom in spot 6 and 14, whereas in 8 and 9 it was scarcely predictable.

In this context, the advent of new remote sensors and the wireless communication technologies has led to develop real time monitoring systems for assessing the health status of seawater by providing information about rapid hydrologic changes recognized as a critical need for early identification of alarm events [5] - [10].

In the proposed work, at the suggestion of Apulia-Regional Agency for the Environmental Prevention and Protection (ARPA), we propose to use a previously designed low cost ISO/IEC/IEEE 21451-2 compliant sea water probe [11], as the main element of a water monitoring sensor network based on 21451-2 and 1451.5 standards.

This probe is able to measure water temperature, salinity/conductivity, turbidity and chlorophyll-a concentration as biological indicators of water eutrophication. Unlike the manual measurement campaigns, this approach would be unable to provide information on the composition of the vertical water column; it would rather provide information relative to a fixed depth and characterize the dynamic properties of marine ecosystem at adequate temporal and spatial scales. In addition, the great advantage would be the implementation of an event-based network, capable of detect whether a fixed threshold is exceeded and to dispatch alert messages to people enrolled on the alert mailing list.

## II. IEEE 21451-X STANDARDS INTRODUCTION

This family of standards has been introduced almost fifteen years ago to overcome the growing e-babel due to company development of proprietary standards concerning sensor network [12]. The IEEE1451 project has not been meant to be a mandatory directive for companies, but rather a collection of guidelines to implement versatile networks of smart interchangeable sensors with different brands. The key feature of this standard is that the data of all transducer are sent on the Internet with the same format, independent on the sensor physical layer (wired or wireless) [13]. Moreover thanks to the open nature of this standard, different manufacturers can produce products with the assurance that they will self-configure and seamlessly integrate and operate with products from other manufacturers.

The IEEE 1451.x is also an evolving standard, recently updated, revised and accepted as the new International Standard 21451-x, thanks to the joint efforts of ISO, IEC and IEEE, and is constantly adapted to emerging communication technologies.

### A. Transducer Electronic Data Sheet

The Transducer Electronic Data Sheet (TEDS) is the heart of a system based on this standard and its implementation is

defined in ISO/IEC/IEEE 21450, previously known as IEEE 1451.0. It is structured to contain all the typical information about a sensor (Fig. 2), such as the physics variable to be measured, the span, the detectivity, the frequency response, the calibration coefficients, and eventually other user defined additional entries. These data can be stored into the sensor to be read when requested by the system or can be hosted on line in the form of Virtual TEDS. The latter case is intended to consider those sensors for which the adaptation to the standard would be too expensive for companies [14][18], for instance sensor working at high temperature or simply to let older technologies to still be used in modern smart networks.

```

Channel TEDS:
TEDSID: 0 3 1 1
CalKey: 4 // Calibration correction is applied in the TIM
ChanType: 0 // Sensor
Units:
  Type: 0
  rad^(0)sterad^(0)m^(-3)kg^(1)s^(0)A^(0)K^(0)mol^(0)
Cd^(0)
  Extension: 0
LowLimit: 0 // Operational lower range limit
HiLimit: 1E-2 // Operational upper range limit
OError: 2E-7 // Uncertainty under worst-case
SelfTest: 1 // Self-test function provided
MRange: 0 // No multi-range capability
Sample:
  SampleMod: 1 // Single-precision real
  SampleModLength: 4 // Number of octets (float32)
  SampleSigBits: 16 // Number of bits from the converter
UpdateT: 0.000
RSetupT: 1.010 // Read setup time
SPeriod: 0.001 // Minimum sampling period
WarmUpT: 0.500 // Warm-up time
RDelayT: 0.001 // Read delay time

```

Fig. 2. Extract of the Channel TEDS memory content for Chl-a sensor

### B. TIM and NCAP modules

The standard also identifies two abstract blocks, the *Transducer Interface Module* (TIM) and the *Network Capable Application Processor* (NCAP), to be implemented together or on different devices, depending on the application context.

Different transducer channels may compose the first block, each one representing a sensor/actuator or an event sensor and it is supposed to encapsulate the relative TEDS (Fig. 3). The NCAP instead may be any device with a network interface, e.g. a personal computer or an embedded device and should make sure that the TIM is visible from the rest of the network [13].

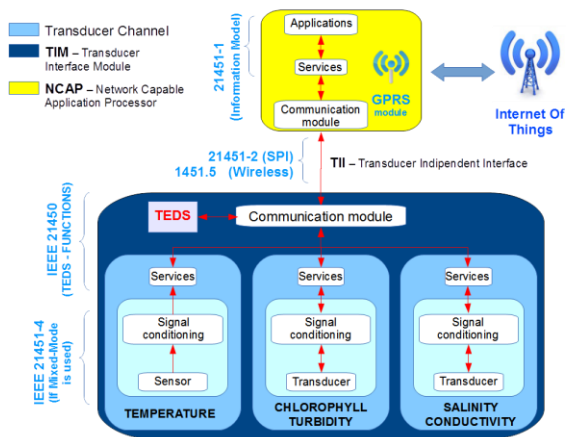

Fig. 3. IEEE 21451 Probe abstract layers

The behavior of TIM module (WTIM if wireless), its ability to generate message and replies to requests coming from the NCAP, as well as message structures and required/optional command it should respond to, are also defined in 21450. With respect to the NCAP module, TIM side implementation follows guidelines defined in 21450, whereas for network side implementation it follows 21451-1 directives, which defines web services and applications it should provide. The communication layer between the TIM and the NCAP is the *Transducer Independent Interface* (TII). It includes different technologies, from point to point communication defined in 21451-2, to mixed-mode ones defined in 21451-4 or 21451-7 for RFID sensors. The wireless interface is also available and defined in 1451.5, but it is waiting to be revised and accepted as an international standard.

### C. Common Commands

ISO/IEC/IEEE 21450 defines many command classes and different command functions for each class. These commands are intended to be universal commands for all ISO/IEC/IEEE 21451 compliant devices. Thus all sensors and actuators should for instance respond to *Trigger* commands, with the underlying difference that the former should store the measured value into a buffer when triggered, waiting for a succeeding *Read Transducer Channel data-set segment* command, whereas the latter should behave actuating data previously written inside its buffer by means of *Write Transducer Channel data-set segment* command.

These commands have to be structured in a message according to its format definition in 21450. Therefore, in order to query a sensor connected to TIM channel number 1 or to drive an actuator on channel number 2, two messages need to be sent to each channel, each one made up of 6 bytes at minimum, with a variable data payload which length is defined in *Length* field, as shown in Table I. However, it is also feasible to dispatch the same message to many different transducers, in fact in this case the standard foresees the creation of appropriate proxy groups.

TABLE I  
COMMAND EXAMPLES

Command	Channel Address	Command Class	Command Function	Length	Data	
<b>Sensor</b>						
Trigger	0x00	0x01	0x03	0x00	0x00	-
	Channel 1		Operate	Trigger	MSB	LSB
Read	0x00	0x01	0x03	0x00	0x00	-
	MSB	LSB	-	Read	MSB	LSB
<b>Actuator</b>						
Write	0x00	0x02	0x03	0x02	0x00	0x01
	Channel 2		Operate	Write	MSB	LSB
Trigger	0x00	0x02	0x03	0x03	0x00	0x00
	MSB	LSB	-	Trigger	MSB	LSB

Using a Logic Analyzer it's easier to understand how a 21451 transaction is made; for instance, Fig. 4 reports what happens when the NCAP forwards a "Read TransducerChannel data-set segment" command to the 21451-2 compliant probe through a SPI interface (Serial Peripheral Interface), to read the seawater temperature on channel 1.

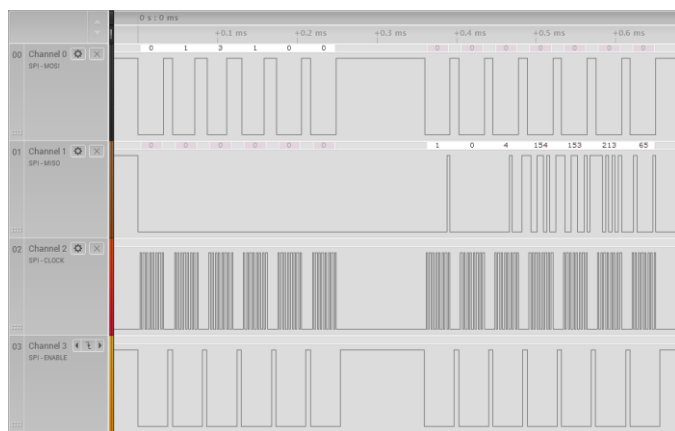

Fig. 4. SPI Query and response of Temperature channel using Salee Logic Analyzer; Trigger command has been sent before time zero and therefore it's not visible

According to message/reply definition in 21450, the NCAP sends a Read command to the TIM as defined in Table I. After the command has been parsed, the reply message containing the acquired sample is stored inside the TIM output buffer, ready to be sent back on master request. Now the NCAP reads the first reply octet, which contains the Success/Fail Flag and checks whether it is respectively bigger or equal to zero. Value 1 means that operation was successful and the NCAP can thus continue querying the next two octets that, once merged, contain the length of the payload, i.e. the number of remaining octets.

Because the temperature value has a floating point precision, which needs 4-bytes to be stored, the payload contains four octets (154, 153, 213, 65) obtained using a simple union structure:

```
union temp_val {
    byte b[4];
    float temp;
} T;
```

Once received, the NCAP merges the four bytes to obtain the original value of 26.7°C acquired by the TIM first channel.

It is reasonable that the additional complexity required for 21450 command packet recognition would also introduce a greater delay in communication systems. In fact it involves an approximately average increase in TIM reaction time of 50% [15] from the mean value of 2 ms without 21451 to almost 3 ms with it. Although this value may appear considerable in some specific cases, it is generally negligible within modern and powerful microcontrollers.

### III. MEASUREMENT CONTEXT

Coastal monitoring is a tough challenge in comparison to local smart sensor networks, mainly due to the hostile environment and long distances involved. In addition, the most important biological indicator of water quality, the chlorophyll-*a* molecule, does not exhibit a homogenous distribution in seawater but rather a spatial patchiness [16], meaning that events of potential interest can even happen on a scale of a few tens of meters.

Thus, considering that the Water Framework Directive (WFD-2000/60/EC [17] indicates 1 mile as the monitoring limit distance from the coast and that Apulia region has almost 800 km of coastline, any kind of widespread homogenous monitoring would be unfeasible and different approaches must be taken in consideration.

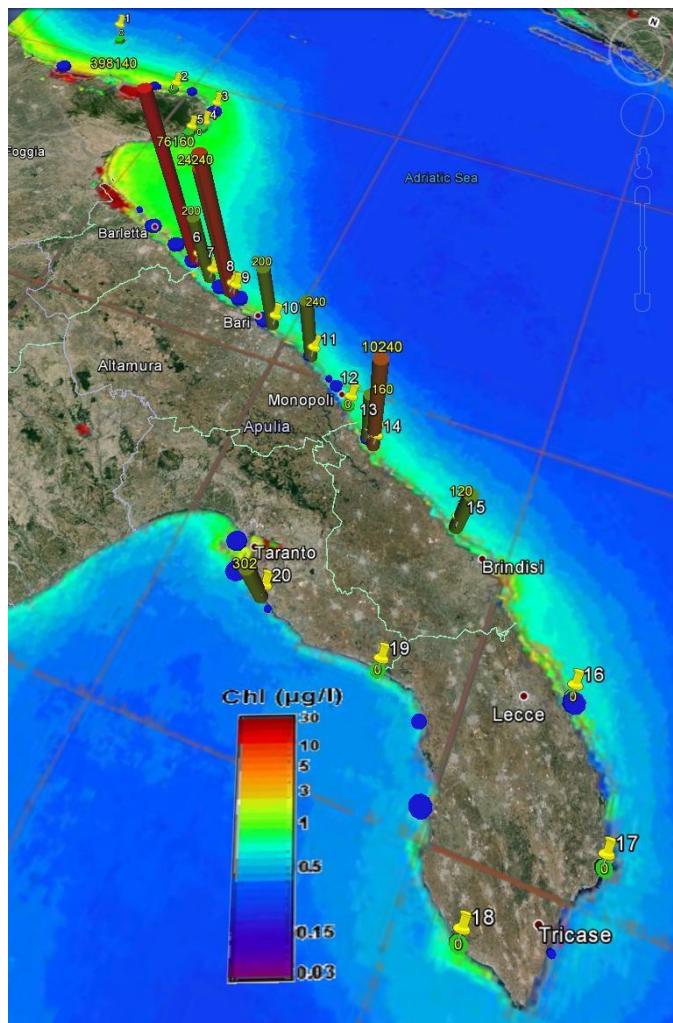

Fig. 5. Different data superimposed on Apulia region Sat image: yellow placemarks and columns are respectively values on abscissa and ordinate of Fig. 1; blue disks are wastewater treatment plants (size is proportional to the number of served inhabitants); remote image of chlorophyll-*a* concentration in color map (MERIS/MODIS A 2006/2011).

The exact positions of the sampling points must be accurately determined by the team of biologists in charge of monitoring, taking into account the history of the observed place, the influence of anthropogenic factors, as well as geo-hydro morphological features and the presence of usual marine currents. The relationship between nutrient disposability and algae replication is better appreciated when overlapping on a satellite image of Apulia region (Fig. 5), the second series of data in Fig. 1 and positions of wastewater treatment plants (responsible, together with the rivers, for the introduction of nutrients into the sea).

Merging the above data sets, two main scenarios arise which lead to different network layout, optimized for further analysis:

- 1) Coastal water bodies known for their propensity to develop environmental critical situations, which need a constant monitoring.
- 2) Transitional waters, in which the investigation of the

influence area of possible pollution impacts would be of great interest.



Fig. 6. Transects monitoring: O.V. cell concentration in columns, water current flow (red), bathymetric lines (blue), transects (white), current fortnightly monitored spots (yellow), ideal additional spots (white).

The former is mainly related to those shores characterized by a rocky substrate, especially in areas with high nutrient density or with natural geomorphological features that would promote algae replication.

For instance spots 8 and 9 (Fig. 5), magnified in Fig. 6, fairly adapt to this description. They are placed respectively at 2.6 km and 4 km from the wastewater treatment plant (the red box), on the same bathymetric line (10 m of depth), which makes more comparable the two readings.

If a sensor network is adopted instead of fortnightly manual sampling, a deeper time resolution can be reached, while decreasing reaction time in case of indicators exceeding their limit values. A more accurate control of shore water quality may also be achieved if more probes are used, monitoring the same transects they rely on, i.e. the line perpendicular to the coastline (Fig. 6).

The latter scenario involves zones where nutrient are directly released, like in front of wastewater drains or towards river estuaries. In this case biologist would prefer a different spatial distribution of sensor probes, more suitable to assess the edges of a possible pollution impact zone.



Fig. 7. Transitional water monitoring: Radial probe distribution (white) for impact zone detection. Example of Chlorophyll-a (red) and inverse salinity (yellow) gradient maps that can be obtained.

Taking as an example the Ofanto River (Fig. 7), during the period 2010/2011 it has received a low LIMeco score in terms of intake of macronutrients such as  $\text{NO}_3$ ,  $\text{PO}_4$ , but also considering *Escherichia coli* (*E. coli*) concentration, surfactants, herbicides, pesticides or silicates; on the other hand it flows in a shore with sandy substrate, which does not favor the establishment of microalgae colonies. Unfortunately, the sandy bottom slopes more gently than the rocky one, eventually requiring greater distances to be covered.

An easily reconfigurable sensor network may be used in this situation to map the pollutant impact zone with high spatial resolution. Being for instance  $f(x,y)$  a scalar field representing the water concentration of chlorophyll-a or of another indicator:

- $\nabla f$  is a vector field containing important information regard actual parameter diffusion
- $\nabla \cdot \nabla f$  is a scalar field containing additional information regard possible illegal sewages or pollutants accumulation spots.

#### IV. SYSTEM ARCHITECTURE

Considering that internal distances between sensor probes in the two scenarios are likely less than 1 km and that maximum distances from farthest probe to the shore is generally below 1.852km (1 mile), we propose to use two slightly different probe solutions for field covering, which can be integrated to work together:

##### Type A:

This is a self-sufficient buoy, conceived for isolated spot data surveying, but it can also operate in a local sensor network coordinating Type B probes.

By leveraging existing infrastructure (providers APN), we propose to equip each Type A probe (Fig. 8) with a second generation (2G) General Packet Radio Service (GPRS) module. This device contains the TIM module but also act as an NCAP, being able to provide TCP features based on IPv4 protocol for internet access through Gateway GPRS Support Node (GGSN) (Fig. 10), with services and applications described in ISO/IEC/IEEE 21451-1. The communication between the NCAP and the TIM module is 21451-2 compliant, while 1451.5 compliance is currently under development adding an NRF24L01+ based (Nordic Semiconductor) wireless module.

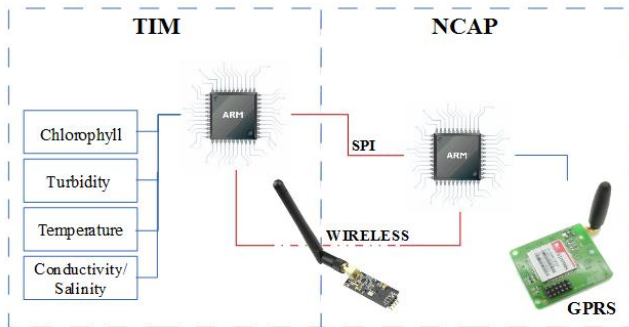

Fig. 8. Abstract probe architecture

Furthermore, the choice of a GPRS module equipped with an integrated GPS receiver would be highly recommended. In this work, SIM908 GSM/GPRS + GPS module from SIMCom Wireless Solutions is used, allowing real time probe tracking and data interpolation over spatial coordinates without the need for an additional module.

In the proposed system two 32-bit ARM Cortex-M4 microcontroller with floating point signal processing unit are used (Fig. 8); the first one to control on board sensors, implementing the TIM block and communicating to the NCAP through Serial Peripheral Interface (SPI) connection, the second to implement di NCAP itself.

The NCAP side must encapsulate an embedded light server able to provide advanced machine-to-machine (M2M) interactions based on the underlying HTTP/1.1 protocol and XML request/response messages as payload to GET or POST HTTP methods. Human interaction is also allowed through a simple HTML user web interface (Fig. 9) which adopts

Asynchronous JavaScript and XML (AJAX) technique for efficient background data exchange between server and web browser, allowing dynamic web page content update.

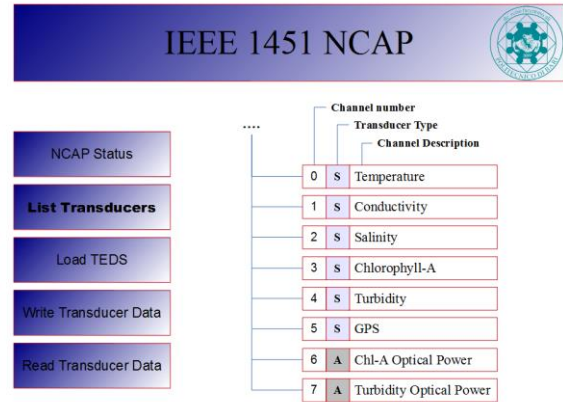

Fig. 9. Simple web server NCAP interface

This behavior may be basically implemented in two different ways, using a Web Server with Common Gateway Interface (CGI) to handle POST requests or with an Application Server designed specifically for use on deeply embedded systems. The former is an older method to handle data returned by a web browser, thus requesting low-level C code, easily error-prone, redefinition of routines needed. Conversely the latter solution is a Lua-based application server (e.g. Barracuda Web Server) that integrates web server functionality in order to handle requests and provide a built-in C/C++ application framework for invoking C/C++ programs. In addition Lua-based servers allow system update through the on-fly program compilation, without the need to take the system down.

In order to control many probes geographically spread out in a single network and grant at the same time a secure data transmission, an Internet Protocol-Virtual Private Network (IP-VPN) has to be adopted. Using a fixed IP address and a VPN router inside the control room, a secure tunnel is created over the internet, able to ensure that only eligible users have access to data during the overall transmission.

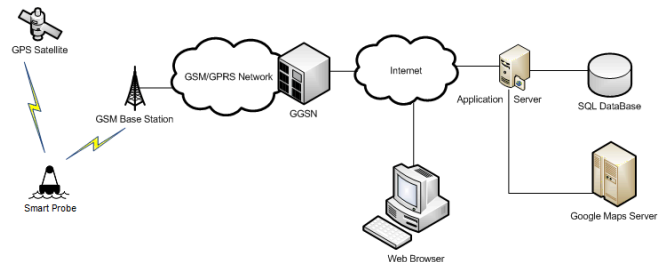

Fig. 10. Network architecture and services

##### Type B:

This device is composed by the same Transducer Channels as Type A, being able to monitor the same parameters, plus a dedicated GPS module. Nevertheless, its interface implementation is slightly different from type A; in fact it is not independent and it should actually work in a network,

acting as a Wireless-TIM (IEEE 1451.5 compliant) connected to the NCAP inside Type A buoys by mean of NRF24L01+ module.

The PHY TEDS data-block of this device contains specific information about the communication channel as defined in 1451.5, like Radio type, Max Data throughput, Authentication and others. Despite the fact that the radio interfaces actually covered by the standard are only four

- IEEE 802.11
- Bluetooth
- ZigBee
- LoWPAN

the adopted one does not implement any listed network stack, therefore the Manufacture specific code (255) is used. The communication between NCAP and WTIM in fact relies on Nordic Semiconductor MultiCeiver™ technology, which let the use of up to 6 data pipe for 1:6 star networks and Enhanced ShockBurst™ which features automatic packet handling, automatic acknowledgment and retransmission. Considering operation in a harsh environment, this is an extremely useful built-in function. In this configuration Type A probes gather the Primary RX status, while Type B the Primary TX, allowing bi-directional communication, simply configuring internal register map through SPI interface. In order to overcome the 6:1 network size limitation, a mesh network implementation using the same module is actually under investigation.

The adopted NRF24L01 + PA + LNA module has a transmitting Power Amplifier and a receiving Low Noise Amplifier, which respectively grant a maximum output power of +20 dBm and a receiving sensitivity of -104 dBm at 250 kbps, a more than sufficient speed if a real-time stream communication is not required.

In order to assess the network feasibility, the signal strength between sensor probes needs to be evaluated. For this purpose an important parameter is the Free Space Loss, defined as

$$FSL = -20 \log_{10} \left( \frac{\lambda}{4\pi d} \right) \quad (1)$$

where  $\lambda$  is the signal wavelength and  $d$  is the distance between transmitter and receiver antennas. Plotting the value of FSL with respect to the distance (Fig. 11) and fixing a link length of 1 km between transmitter and receiver, leads to  $FSL_{MAX} = 100$  dB; doubling the distance the FSL increases of 6 dB.

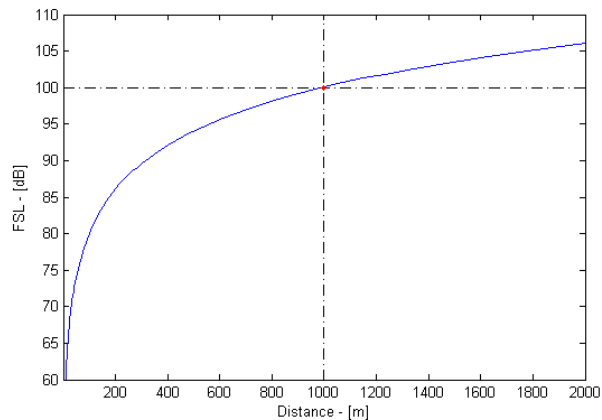

Fig. 11. Free Space Loss vs. Transmitted distance (carrier frequency is 2.4 GHz)

Considering 0.5 dB as cable loss for a length of 1 m, we can now use the module parameters to perform a link budget.

TABLE II  
LINK BUDGET CALCULATION

	20 dBm	(TX Power)
+	2 dBi	(TX antenna gain)
-	0.5 dB	(TX cable loss)
+	2 dBi	(RX antenna gain)
-	0.5 dB	(RX cable loss)
	23 dB	<b>Total Gain</b>
-	100 dB	(Free Space Loss @ 1km)
	-77 dB	<b>Expected signal level</b>
-	-104 dBm	Sensitivity @ 250 kbps
	27 dB	<b>Link Margin</b>

Though the Link Margin is largely above the confidence threshold of 10 dB, further considerations need to be carried out. In fact, despite marine environment is characterized by the absence of almost any obstacle, the height of the antenna over the water level plays also an important role.

If considering the signal reflection upon seawater (approximated as a perfect conductor) and using 2-ray model [18], a new value can be derived for Propagation Losses

$$\begin{aligned} PL(dB) &= 40 \log(d) - (10 \log(G_t) + 10 \log(G_r) + 20 \log(h_t) + 20 \log(h_r)) \\ &= 40 \log(1000) - (20 \log(2) + 40 \log(1)) = \\ &= 113.98 \end{aligned} \quad (2)$$

where  $G_t$  and  $G_r$ ,  $h_t$  and  $h_r$ , are respectively the transmitting and receiving antenna gain and height (assumed 1 m over seawater level). Using Propagation Losses instead of Free Space Losses in Table II, leads to a reduced Link Margin equal to 13 dB.

In addition, for microwave communication (this is the case for nRF24 module that transmit at 2.4 GHz in the ISM band) it is not sufficient that antennas are on the same Line of Sight (LoS), they also must have at least a clear first Fresnel Zone, because obstacles may cause reflection and diffraction

introducing additional signal paths. In order to take into account these effects, the  $n$ -th Fresnel zone define a portion of space enclosed by an ellipsoid, for which a potential obstacle on the path may in fact interfere constructively or destructively, respectively in even and odd zones. However if the first Fresnel zone is kept clear at least at 55% [18], then further Fresnel zone clearance does not significantly affect diffraction losses. Considering a link distance of 1 km, the 1<sup>st</sup> Fresnel Zone radius in the middle distance, i.e. for  $d_1 = d_2 = 500$  m, is

$$F_n = \sqrt{\frac{n\lambda d_1 d_2}{d_1 + d_2}} = \sqrt{\frac{\lambda 500^2}{1000}} = 5.59m \quad (3)$$

$$F_{55} = 5.59 \cdot 0.55 = 3.07m \quad (4)$$

This means that the antenna's height of each probe should be at least 3 m for total losses to be equal to FSL, confirming that PL due to a shorter antenna are higher than FSL.

Careful mathematical simulations should be carried out to evaluate the effects of rough seas, which cause multiple diffraction due to the waves ridges; however, an estimate of the minimum loss values can be made considering the diffraction due to a single ridge placed in middle, using Knife-edge Diffraction model [18].

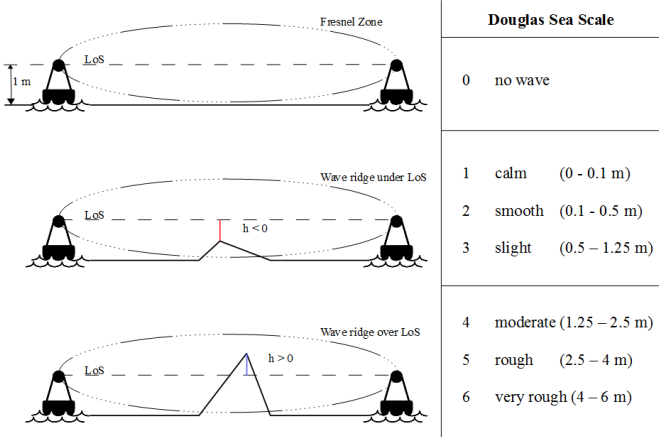

Fig. 12. Edge values used in the model, related to Douglas Sea scale

For each wave height in Fig. 12, dimensionless Fresnel-Kirchhoff diffraction parameters are computed as follow

$$v = h \sqrt{\frac{2(d_1 + d_2)}{\lambda d_1 d_2}} \quad (5)$$

where  $h$  is equal to wave ridge height minus LoS height and  $d_1, d_2$  are assumed to be equal to 500 m. Using Lee [19] approximation, the numerical relation between Douglas Sea scale and Diffraction loss is calculated and reported in Fig. 13.

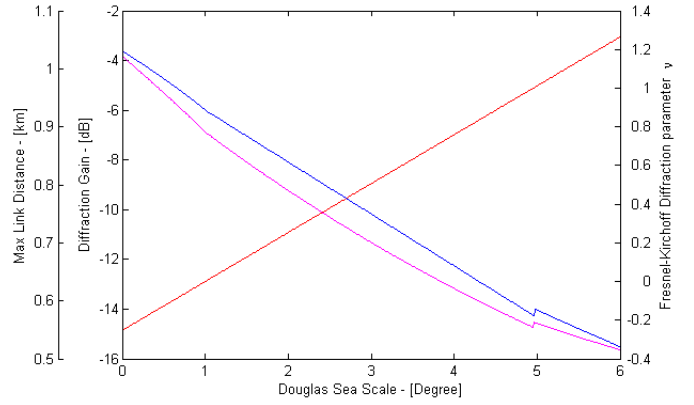

Fig. 13. Diffraction Gain (blue) and Fresnel-Kirchhoff Diffraction parameter (red) for  $d = 1$  km; Maximum link distance (magenta) with Link Margin = 10 dB

Diffraction Loss graph suggests that using an antenna height of 1 m and a limit distance of 1 km, the link strength is just enough for calm water to leave 10 dB of Link margin and it rapidly degrades with sea rough increasing.

At last, a coverage simulation for analytical results verification has been performed (Fig. 14), showing that green zone has 1 km radius as expected; further investigation will also be carried out in order to compare theoretical values with experimental data.



Fig. 14. Coverage simulation around central buoy ("415m" in Fig. 7): green zone has strong signal (Link Margin > 10 dB), yellow zone has weak signal (Link Margin < 10 dB)

## V. DATA ACQUISITION AND QUERYING

The complexity of data survey system depends on the number of elements to be monitored and on the required sampling interval, from occasional to real-time readings.

For small networks with 2-3 scheduled readings per day, a manual acquisition through probe's web interface carried out by qualified personnel may be a sufficient solution.

When the number of network elements increases or when a more intense and flexible access to data is required, higher performance solutions should be adopted. An application

server (Fig. 10) inside the VPN network would provide customer defined services and applications, like for instance a user-friendly programmable interface for automatic data acquisition based on activity scheduling. Furthermore user defined set of rules may be assigned to heterogeneous group of sensor, joined by spatial, technological or semantic affinity, exploiting IEEE 21451 underlying capabilities for sensor proxy groups definition.

All the data acquired by routines running on the application server will be stored inside a MySQL-driven Database for subsequent querying or for support to decisions through statistical analysis performing on collected Big Data: clustering, classification and correlation across different data sets (i.e. collaborative filtering).

Geographic data coming from GPS chipset will also be useful for an easy visualization of the entire system. In fact, using Google Maps APIs it is possible to show real-time probe's position (Fig. 15) directly on the map to provide contextual interaction.



Fig. 15. Conceptual scheme of system architecture superimposed on a satellite image of the Apulia region (ITALY)

## VI. CONCLUSIONS

We have analyzed two typical scenarios involved in seawater quality monitoring and we have proposed two solutions that are not mutually exclusive, but can rather work together, extending the potential of the monitoring system. The former, fully independent, is conceived for monitoring isolated spots, whereas the latter is intended to be an extension of the first one, in those cases where a higher spatial resolution is needed.

The proposed sea water monitoring system is to all effects a Decision Support System (DSS), at least according to its definition in [20]: that is any system that might support decision making. Explicit set of rules or decision it should make are a matter for biologists, anyway its implementation would result in an immediate increase of the effectiveness of the analysis as it provides support to all those who need to make strategic decisions in the face of problems that cannot be solved with a conventional approach.

The use of the standard 21451, besides increasing the robustness of the system, also provides considerable flexibility. Once implemented, new devices can be added without having to make any further changes to the network. The abstraction that distinguishes a 21451-based network of sensors would allow the introduction of other control units distributed in the territory in order, for example, to monitor also air pollution [21]. All data would accrue in a single collection center drastically decreasing the reaction time in front of potential criticality.

## ACKNOWLEDGMENTS

The authors would like to thank Ing. Ilias Ioannou from Planetek Italia s.r.l. for his contribution in computer science problems defining.

## REFERENCES

- [1] G. Andria, G. Cavone, A. M. L. Lanzolla, "Modelling Study for Assessment and Forecasting Variation in Urban Air Pollution", *Measurement*, vol.41, pp. 222-229, 2008.
- [2] G. Andria, G. Cavone, V. Di Lecce, A. M. L. Lanzolla, "Model Characterization of Measurement Environmental Pollutants via data Correlation of Sensor Output", *IEEE Trans. on Instrumentation and Measurement*, vol. 54, pp. 1061-1066, 2005.
- [3] F. Adamo, G. Andria, G. Cavone, C. De Capua, A. M. L. Lanzolla, R. Morello, M. Spadavecchia, "Estimation of ship emissions in the port of Taranto", *Measurement Journal of Imeko*, vol. 47, pp. 982-988, 2014.
- [4] *Ostreopsis Vulgata Database provided by Puglia-Regional Agency for the Environmental Prevention and Protection (ARPA): www.arpa.puglia.it/web/guest/monitoraggiostreopsis*
- [5] H. B. Glasgow, JoAnn M. Burkholder, R. E. Reed, A. J. Lewitus, J. E. Kleinman, "Real-time remote monitoring of water quality: a review of current applications, and advancements in sensor, telemetry, and computing technologies" *Journal of Experimental Marine Biology and Ecology*, vol 300, pp.409-448, 2004.
- [6] A. Charef, A. Ghauch, P. Baussand, M. Martin-Bouyer "Water quality monitoring using a smart sensing system", *Measurement*, vol. 28, pp. 219-224, 2000.
- [7] F. Adamo, C. De Capua, P. Filianoti, A. M. L. Lanzolla, R. Morello, "A Coastal Erosion Model to Predict Shoreline Changes", *Measurement Journal of Imeko*, vol. 47, pp. 734-740, 2014.
- [8] X. Xiao-Gang, Z. Dong-Zhi, L. Yu-Guang, Y. Jian-Hong, X. Peng, W. Lin, "An Overview of Remote Sensing of Chlorophyll Fluorescence", *Ocean Science Journal*, vol. 42, no. 1, pp. 49-59, 2007
- [9] J.A. Skinner, M.F. Lambert, "Using Smart Sensor Strings for Continuous Monitoring of Temperature stratification in Large Water Bodies. *IEEE Sensors Journal*, vol. 6, no. 6, pp 1473-1481, 2006.
- [10] Y. Zhang, Sampsa S. Koponen, M. T. Hallikainen, J. T. Pulliainen "Application of Empirical Neural Networks to Chlorophyll-a Estimation in Coastal Waters Using Remote Optosensors", *IEEE Sensors Journal*, vol.3 no. 4, pp.376-382, 2003
- [11] F. Attivissimo, C. Guarnieri Calò Carducci, A. M.L. Lanzolla, A. Massaro, M. R. Vadrucchi, "A portable Optical Sensor for in-situ measurements of chlorophyll a and water transparency in seawaters", accepted on *IEEE Sensor Journal*.
- [12] IEEE, The Institute of Electrical and Electronics Engineers, "IEEE Standard for a Smart Transducer Interface for Sensors and Actuators— Transducer to Microprocessor Communication Protocols and Transducer Electronic Data Sheet (TEDS) Formats, IEEE Standard 1451.2"–1997, Inc., NY, 1997.

- [13] D. Wobschall "Networked sensor monitoring using the universal IEEE 1451 Standard" *Instrumentation & Measurement Magazine*, IEEE, vol. 11, no. 2, pp 18-22, 2008.
- [14] J. Wiczer, "Smart Interfaces for Sensors", *Proceeding Sensor Expo – Smart Sensor Session*, Chicago, IL, 2001
- [15] J. Popelka, P. Paces, "Performance of smart sensors standards for aerospace applications", *Electrical Review*, vol. 88, pp. 229-232, 2012.
- [16] L.de Montera, M. Jouini, S. Verrier, S. Thiria, M. Crepon, "Multifractal analysis of oceanic chlorophyll maps remotely sensed from space", *Ocean Science Discussions*, Vol. 7 no.2, pp.219-229, 2011.
- [17] European Parliament "Directive 2000/60/EC of the European Parliament and of the Council establishing a framework for the Community action in the field of water policy" , CELEX-EUR Official Journal L 327,pp. 1-72, 23 Octoberr 2000
- [18] .. Theodore S. Rappaport, "Wireless Communication: Principles and Practice", Prentice Hall, 2 edition, January 10, 2002.
- [19] Lee, W. C. Y., "Mobile Communications Engineering", McGraw Hill Publications, New York, 1985.
- [20] R. Sprague, "A Framework for the Development of Decision Support Systems.", *MIS Quarterly*. Vol. 4, No. 4, pp.1-25, 1980.
- [21] N. Kularatna, B. H. Sudantha, "An Environmental Air Pollution Monitoring System Based on the IEEE 1451 Standard for Low Cost Requirements", *IEEE Sensors Journal*, vol. 8, No. 4, pp. 415-422, 2008.