



Politecnico
di Bari

Repository Istituzionale dei Prodotti della Ricerca del Politecnico di Bari

A timed Petri nets model for performance evaluation of intermodal freight transport terminals

This is a post print of the following article

Original Citation:

A timed Petri nets model for performance evaluation of intermodal freight transport terminals / Dotoli, M., Epicoco, N., Falagario, M., Cavone, G.. - In: IEEE TRANSACTIONS ON AUTOMATION SCIENCE AND ENGINEERING. - ISSN 1545-5955. - STAMPA. - 13:2(2016), pp. 7057695.842-7057695.857. [10.1109/TASE.2015.2404438]

Availability:

This version is available at <http://hdl.handle.net/11589/972> since: 2021-03-07

Published version

DOI:10.1109/TASE.2015.2404438

Publisher:

Terms of use:

(Article begins on next page)

A Timed Petri Nets Model for Performance Evaluation of Intermodal Freight Transport Terminals

Mariagrazia Dotoli, *Senior Member, IEEE*, Nicola Epicoco, Marco Falagario, Graziana Cavone

Abstract—This paper presents a general modelling framework for Intermodal Freight Transport Terminals (IFTTs). The model allows simulating and evaluating the performance of such key elements of the intermodal transportation chain. Hence, it may be used by the decision maker to identify the IFTT bottlenecks, as well as to test different solutions to improve the IFTT dynamics. The proposed modelling framework is modular and based on timed Petri Nets (PNs), where places represent resources and capacities or conditions, transitions model inputs, flows, and activities into the terminal and tokens are intermodal transport units or the means on which they are transported. The model is able to represent the different types of existing IFTTs. Its effectiveness is tested first on an example from the literature and then on a real case study, the rail-road inland terminal of a leading Italian intermodal logistics company, showing its ease of application. In the real case study, using the proposed formalism we test the as-is IFTT performance and evaluate alternative possible to-be improvements in order to identify and eliminate emerging criticalities in the terminal dynamics.

Note to Practitioners— The motivation of this work is to present a general modular modeling framework to be used by decision makers of intermodal freight transport terminals for performance evaluation and improvement. In fact, one of the main challenges faced in intermodal transportation is precisely in efficiently and accurately connecting different transportation mode networks into an integrated whole thanks to the key IFTT connector. Using the timed PN formalism in a bottom-up approach, we present general elementary modules that may be systematically combined to represent the intermodal terminal under study. The PN model resulting from the composition of the subnets can be simulated to estimate the system performance. The model provides intermodal terminal designers and managers

Manuscript received February 13, 2015; revised January 23, 2015; accepted February 11, 2015.

M. Dotoli is with the Department of Electrical and Information Engineering, Politecnico di Bari, Bari, Italy (e-mail: mariagrazia.dotoli@poliba.it).

N. Epicoco is with the Department of Electrical and Information Engineering, Politecnico di Bari, Bari, Italy (e-mail: nicola.epicoco@poliba.it).

M. Falagario is with the Department of Mathematics, Mechanics and Management Engineering, Politecnico di Bari, Bari, Italy (e-mail: marco.falagario@poliba.it).

G. Cavone is with the Department of Electrical and Information Engineering, Politecnico di Bari, Bari, Italy (e-mail: graziana.cavone@gmail.com).

The authors wish to thank the GTS - General Transport Service S.p.A. staff and particularly the GM Mr. Giuseppe Desantis for their support in the preparation of this paper.

with important key features. First, it can measure the performance indices of the terminal, i.e., system throughput, resource utilization, etc., and can help detect the system bottlenecks. Further, the model allows testing alternative solutions to emerging criticalities. Future research will consider the use of high level PNs to increase the modelling power of the proposed approach and the structural analysis of the complete IFTT based on the proposed timed PN modular model.

Index Terms—Discrete event systems, intermodal freight transport, modelling, performance evaluation, simulation, timed Petri nets.

I. INTRODUCTION

RECENTLY transport is moving from single-mode (road, rail, sea/river or air) to intermodal, multimodal, and combined transport. Commodities are transferred in the same loading unit, called ISO shipping container or Intermodal Transport Unit (ITU), using two or more modes: road vehicle combinations, rail wagons, river and canal barges, and sea-going ships. Multiple transportation modes allow deploying each individual mode to its best advantage, i.e., combining the major speed, security, reliability and sustainability advantages provided by rail/sea for long distance transport, as well as their lower costs, with the increased space penetration features of road [17]. The combination of several modes into an integrated system provides a more flexible service, as well as more reliable, profitable and sustainable transport [23], [24]. This paper addresses intermodal transport, which may be defined as the activity of conveying freight in unit loads by two or more suitable transport modes, so as to form an integrated transport chain [50].

Despite its numerous advantages, intermodal transport has some critical aspects [25], among which efficiency and performance evaluation and optimization are the most significant. Indeed, the integration of multiple transport modes, decision makers, and types of load units leads to much more complex intermodal planning problems than unimodal ones. As a result, operating inefficiencies may be experienced if the integration of the complex subsystems in the transportation network is not fully effective. In this context, one of the most important and critical elements in the freight transportation chain and the evaluation of its competitiveness is the Intermodal Freight Transport Terminal (IFTT) that provides the interface between modes and also between

shippers and carriers. Therefore, the performance of terminals is crucial for the transportation chain effectiveness and needs to be closely monitored and optimised [12], [34].

The combination of intermodal transport with Information and Communication Technologies (ICTs) has been identified as one of the main actions to improve the effectiveness and efficiency of intermodal transport [34], [43]. This integration clearly shows its advantages when applied to the key elements of the transportation chain, namely IFTTs. In this context, the availability of a suitable computer based simulation model for testing the operational functioning and management of the IFTT allows the analysis, design and control of the intermodal terminal. This leads to achieving better performances of the system and helping the decision makers create the correct strategies to maximize the benefits of intermodal transport while constraining its limitations [3], [7], [12].

In this paper we present a Discrete Event Systems (DES) modular modelling framework based on Timed Petri Nets (TPNs) that, combined with Monte Carlo simulation, allows simulating the dynamics and evaluating the performance of a generic IFTT. The model is a widely extended version of our previous conference paper [19]. To the best of the authors' knowledge, none of the existing works using a DES formalism to represent intermodal terminal adopts a general modular approach, which makes them unsuitable to model and evaluate intermodal terminals that differ from specific case studies. We identify several elementary modules, which, suitably combined by a systematic technique that we adapt from [27], can represent any terminal in the TPN framework. We remark that, although Petri Nets (PNs) are not able to describe in detail all the complex operations of an intermodal system like other simulation tools (such as Arena, Witness, ExtendSim, etc.) -which is not, however, our goal- they offer significant advantages over discrete event simulation tools which motivate our choice [23]. In fact, analytical DES models allow the evaluation and analysis of DESs taking advantage of discrete event simulation models. In particular, in our paper, we combine the TPN modeling of the system with Monte Carlo simulation to obtain statistically accurate estimates of the case studies performance indices [23].

The two main reasons for using TPNs for IFTT modeling and performance evaluation are in the fact that on the one hand PNs allow us to model in a modular and systematic way high dimension DESs such as IFTTs while keeping the physical meaning of the DES subsystems, and on the other hand that TPNs allow the temporization of the activities of the system, so as to quantify their duration and evaluate the IFTT dynamics, during short and/or long time periods, without requiring high computational efforts, even for large nets. Other significant advantages of the use of TPNs are: 1) the graphical aspect, which enables an easily perceived, concise and effective way to design and verify the model; 2) the simple mathematical representation, which allows simulation of the system in software environments considering different conditions characterized by a different level of information shared between terminals and operators and consequently automatically analyze their behavior; 3) the capability to

reproduce typical features of DESs, as priority, synchronization, parallelism, causal-consequence connections and shared resources; 4) the ability to define simple performance indices to evaluate the system behavior; 5) the opportunity to perform structural analyses on the developed net; 6) the possibility, by means of the so-called Generalized Mutual Exclusion Constraints (GMECs) [31], to ensure control policies, which can be implemented through simple monitor places (i.e. adding new places to the net), so as to represent the exchange of information in IFTTs allowed by modern ICT tools, thus allowing to solve some of the recalled intermodal transport criticalities.

The effectiveness of the proposed modeling framework is shown by two case studies, one from the literature [23] and one referring to a real logistics company operator located in Bari (Southern Italy), presented also in [19] and [20]. Thanks to the short computational times, the model allows evaluating different alternatives in order to improve the performance of the examined terminal.

The remainder of the paper is structured as follows: Section II reviews the literature on IFTT models, motivating and positioning our approach; Section III recalls the basics of TPNs; Section IV presents the modelling framework; Section V describes the case studies and reports the results of their performance analysis; Section VI summarizes the conclusions.

II. LITERATURE REVIEW ON INTERMODAL FREIGHT TRANSPORT TERMINALS MODELS

A. Literature review

Numerous contributions in the literature discuss intermodal terminal operations from different perspectives. Comprehensive reviews of the different types of IFTTs are available in [6], [48], [49], and [51]. An overview of terminal operations is given in [33]. Summaries of the operational decisions made in container terminals are provided in [41]. Planning methods in intermodal freight transport at the strategic, tactical, and operational level are surveyed in [10].

This paper addresses the IFTT modelling and performance evaluation at an operational level. At this level, to evaluate the IFTT effectiveness and efficiency as well as to test any corrective action or improvement to its operation, it is imperative to have a good model that can be simulated so as to estimate the terminal performance taking into account its dynamics over time and uncertainties. Toward this end, several models have been proposed in the literature and a review on the techniques adopted to model the stationary evolution of these systems may be found in [2]. However, the main drawbacks of such static approaches lie in their simplicity and the resulting structural inability to fully describe the terminal behaviour. Operations research techniques and particularly mathematical programming approaches have been used for modelling and evaluating several operational issues in the terminal [26], [30]. However, more powerful modelling paradigms are necessary to describe not only the stationary evolution of the system but its full dynamics. Moreover, the operational level activities of the

IFFT are characterized by stochasticity and uncertainty [10]. Hence, a timed and stochastic dynamic model is necessary to fully represent an IFFT.

DES models represent a recognized formalism to successfully model and analyze logistics systems [14], [22], [32] and particularly intermodal terminals [1], [13]. An IFFT can be represented as a DES, whose state evolution depends on the occurrence of discrete events, such as demands, departures, arrivals of transportation means, and acquisitions/releases of resources by vehicles. The related literature may be roughly divided into discrete event simulation models and analytic DES models.

Discrete event simulation models have been widely used for terminal operations [6] providing the great advantage of capturing many details to meaningfully mirror the real system complexities. In [45] the authors present a simulation tool based on discrete event paradigm for the combined rail/road transport in intermodal terminals. Paper [42] describes a discrete event simulation model to analyze the impact of possible growth in sea traffic on land infrastructure in an Italian port. The authors of [5] propose a distributed discrete event container terminal simulator based on object oriented modelling to be used in a port decision support system. Paper [11] develops a discrete event simulation model that covers the hinterland waterway network of a major port in Western Europe in order to analyze the network configuration and the effects of future policy measures for intermodal container transport. In [4] a discrete event simulation model is presented to reproduce the activities in an intermodal maritime terminal and evaluate its performance. However, DES simulation models have two main drawbacks: they are usually customized to the problem at hand so that they typically fail to provide a general framework to model the IFFT; moreover, they are demanding from the computational point of view.

DES analytical models are generally more compact and less computationally demanding than discrete event simulation models. In the class of DES analytical models, several approaches have been proposed based on queuing theory (see [1] and the review therein). In such approaches the terminal is viewed as a queuing system in which ITUs arrive and ask for a service, wait for the service if it is not immediately available, utilize the service, and leave the system after being served. Among the latest contributions, we recall the work in [39], where a Markov chains model is proposed for a cost-benefit analysis of the introduction of new resources in a terminal. In [1] the authors propose a nonlinear discrete-time dynamic model of container flows as a system of queues. Further, in [9] a queuing network-based model is used to optimally manage the container discharge/loading at any berthing point. In [8] a queue-based discrete-time model for planning rail operations in container seaport terminals is presented. However, these queuing theory models have serious practical limitations modelling specific characteristics of IFFTs, such as, e.g., transient flow and time-varying arrival rates.

Another effective class of analytic DES models is that of PN models, which include various formalisms that can successfully model logistics systems and have the merits

outlined in the previous section. In the context of PNs models for IFFTs, [38] proposes a TPNs model of automated container terminals equipped with automated guided vehicles. In [21] the authors present a colored PNs model for automated storage and retrieval systems with rail-guided vehicles. In [29] the authors use PNs for modeling information flows and different interactions in the intermodal transport, referring to a port area, seen as a link between land and marine transport. [16] and [18] respectively use hybrid PNs and TPNs for modelling and analyzing a freight terminal based on the Metrocargo system. In [40] a preliminary PNs model is presented for modelling and simulating the operation at a seaport container terminal. In [37] a colored TPNs model is proposed for air cargo terminal operations. The PNs modeling tool is also used in [23] in order to evaluate the impact of ICTs in the connection between a port and a truck terminal. Finally, [47] uses PNs with predicates to model and evaluate the performance of a specific seaport terminal.

B. Paper contribution

From the discussed literature in the field of PNs models of IFFTs, it is evident that we lack a systematic and general methodology to describe in detail the multiplicity of elements that can influence the dynamics of the terminal and its performance in a PN framework. Although several studies are available regarding intermodal terminal operation and optimization by PNs, little has been reported in the literature regarding their application to the generic IFFT, while one of the main challenges faced in intermodal transportation is precisely in efficiently and accurately connecting different transportation mode networks into an integrated whole, thanks to the key IFFT connector. Furthermore, to the best of the authors' knowledge, none of the existing works presents a modular approach, which makes the available contributions unsuitable to model and simulate intermodal terminals different from the examined ones.

Summing up, the above-mentioned contributions have yet to be extended to obtain a generalized view of complex IFFTs. This paper is a contribution to bridge this gap and to propose a systematic modeling technique to describe the key element of the intermodal transport chain, i.e., the IFFT, in a generic and modular bottom-up fashion. In particular, we present several elementary TPN models of the subsystems constituting an IFFT, together with interface nets, called Routing Networks (RNs) [27] that allow the subsystems' connection and communication in a standardized and systematic way. The proposed framework represents a significant tool for modelling the information flows and the different interactions in the IFFT in a simple and systematic way. Thanks to the short computational times, the model allows decision makers to synthetically evaluate the IFFT performance and compare different alternatives to emerging criticalities.

III. BASICS OF TIMED PETRI NETS

A. Timed Petri Nets (TPNs)

PNs are a widely used tool for describing the structure and

dynamics of DESs, such as computer systems, manufacturing systems, communication systems, etc. This section summarizes some basic definitions on PNs. Interested readers may refer to [15] and [44] for additional details.

A TPN is a bipartite digraph described by the five-tuple $TPN=(P, T, \mathbf{Pre}, \mathbf{Post}, \mathbf{F})$, where P is a set of places with $|P|=m$, T is a set of transitions with $|T|=n$, denoting with the symbol $|A|$ the cardinality of the generic set A . The set of transitions T is partitioned into the set T_I of immediate transitions (represented by bars), the set T_S of stochastic transitions (represented by boxes) and the set T_D of deterministic timed transitions (represented by black boxes). In general, it is possible to associate with stochastic transitions any type of probability distribution, depending on the represented stochastic event. We remark that in this paper we use exponential distributions because of their simplicity (they require one parameter only) and because they are memoryless: this choice is quite common in the literature where the inter-arrival times of transportation means for arrival processes, that are purely random and independent, are conveniently represented using the single parameter of the exponential distribution, see for instance [23], [35] and the related discussion in [53]. Moreover, this choice allows a comparison of the obtained results with [23] for the first case study.

The *pre-incidence matrix* $\mathbf{Pre}:P \times T \rightarrow \mathbb{N}^{m \times n}$ and the *post-incidence matrix* $\mathbf{Post}:P \times T \rightarrow \mathbb{N}^{m \times n}$ respectively specify the arcs connecting places and transitions. More precisely, for each $p \in P$ and $t \in T$, $\mathbf{Pre}(p,t)$ ($\mathbf{Post}(p,t)$) is a natural number indicating the arc multiplicity if an arc going from p to t (from t to p) exists, and it equals 0 otherwise. Moreover, function $\mathbf{F}:T \rightarrow \mathbb{R}^+$ specifies the timing associated with each transition. In particular, for each deterministic timed transition $t_j \in T_D$, $\mathbf{F}(t_j)=\delta_j$ indicates its (constant) firing delay δ_j ; for each exponentially distributed timed transition $t_j \in T_S$, $\mathbf{F}(t_j)=1/\lambda_j$ specifies the average firing delay, where λ_j is the parameter of the corresponding exponential distribution; for each immediate $t_j \in T_I$, $\mathbf{F}(t_j)=0$ denotes the corresponding zero firing delay. Note that \mathbb{N} is the set of non-negative integer numbers and \mathbb{R}^+ is the set of non-negative real numbers.

The $m \times n$ *incidence matrix* of the net is defined as follows:

$$C = \mathbf{Post} - \mathbf{Pre}. \quad (1)$$

Given a TPN, for each place $p \in P$ the following sets of transitions may be defined: $\bullet p = \{t \in T: \mathbf{Post}(p,t) > 0\}$, named pre-set of p , and $p \bullet = \{t \in T: \mathbf{Pre}(p,t) > 0\}$, named post-set of p . Analogously, for each transition $t \in T$ the following sets of places may be defined: $\bullet t = \{p \in P: \mathbf{Pre}(p,t) > 0\}$, named pre-set of t , and $t \bullet = \{p \in P: \mathbf{Post}(p,t) > 0\}$, named post-set of t . Moreover, a transition $t \in T$ is called *source (sink) transition* if it has no input (output) arcs, i.e., it holds $\bullet t = \emptyset$ ($t \bullet = \emptyset$). Similarly, a place $p \in P$ is called *source (sink) place* if it holds $\bullet p = \emptyset$ ($p \bullet = \emptyset$). A TPN with at least a source or sink place is called place-bordered.

The marking of a TPN is a mapping $\mathbf{M}: P \rightarrow \mathbb{N}^m$, assigning

to each place of the net a nonnegative number of tokens. \mathbf{M} is described by an m -vector and the i -th component of \mathbf{M} , indicated with $\mathbf{M}(p_i)$, represents the number of tokens in the i -th place $p_i \in P$. A TPN system $\langle TPN, \mathbf{M}_0 \rangle$ is a TPN with initial marking \mathbf{M}_0 . The value of the marking at time τ is denoted $\mathbf{M}(\tau)$.

The enabling of a transition depends on the marking of all its input places. More precisely, a transition $t_j \in T$ is enabled at a marking \mathbf{M} if and only if (iff) for each $p \in \bullet t_j$, it holds:

$$\mathbf{M}(p) \geq \mathbf{Pre}(p, t_j) \quad (2)$$

and the symbol $\mathbf{M}[t_j\rangle$ denotes that $t_j \in T$ is enabled at marking \mathbf{M} . The enabling degree of t_j at \mathbf{M} is equal to [15]:

$$\mathit{enab}(\mathbf{M}, t_j) = \max\{k \in \mathbb{N} \mid \mathbf{M} \geq k \cdot \mathbf{Pre}(\cdot, t_j)\}. \quad (3)$$

To deal with nondeterminism in the TPN evolution, policies for the net dynamics have to be defined regarding service (to decide what is the influence of the enabling degree of a transition on the net dynamics), memory (to decide what happens to the samplings of distributions that have not been used), and choice (to decide which transition fires next) [15]. Using the so-called infinite-server semantics [15], it is possible to associate with t a number of clocks that is equal to $\mathit{enab}(\mathbf{M}, t)$. Each clock is initialized to a value that is equal to the time delay of t , if t is deterministic, or to a random value depending on the distribution function of t , if t is stochastic. The values of clocks associated to t decrease linearly with time, and t fires when the value of one of its clocks is null (if n clocks reach simultaneously a null value, then t fires n times). In particular, if a transition t_j fires n times at time τ , then its firing at $\mathbf{M}(\tau^-)$ yields a new marking $\mathbf{M}(\tau)$ such that:

$$\mathbf{M}(\tau) = \mathbf{M}(\tau^-) + C \cdot \overset{\mathbf{u}}{t}_j \quad (4)$$

where $\overset{\mathbf{u}}{t}_j$ is a firing vector associated with the j th canonical basis vector. The notation $\mathbf{M}[\sigma \rangle \mathbf{M}'$ indicates that σ , a sequence of transitions, (firing sequence) may fire at \mathbf{M} yielding \mathbf{M}' . Marking \mathbf{M} is said *reachable* from $\langle TPN, \mathbf{M}_0 \rangle$ iff there exists a firing sequence σ such that $\mathbf{M}_0[\sigma \rangle \mathbf{M}$. The set of all markings reachable from \mathbf{M}_0 defines the reachability set of $\langle TPN, \mathbf{M}_0 \rangle$ and is denoted by $R(TPN, \mathbf{M}_0) = \{\mathbf{M} \in \mathbb{N}^m \mid \exists \sigma : \mathbf{M}_0[\sigma \rangle \mathbf{M}\}$.

In our work, we consider the infinite-server semantics framework [15]. This depends on the macroscopic level of detail of the net, where we do not implement a microscopic model of the system, so that it is not necessary to use a single- or k -server semantics for the whole net. In addition, we consider the so-called enabling memory policy [15]. This means that if a transition enabling degree is reduced by the firing of a different transition, then the disabled clocks are not taken into account in the future enabling. Hence, each transition keeps memory of the current enabling conditions only. Furthermore, after a firing, a time to firing is drawn for each new enabling of exponential transitions while the others do not change. Moreover, if some immediate or deterministic transitions are in conflict, then one is randomly fired. To resolve conflicts between exponential enabled transitions, the transition with shortest firing delay is chosen to fire.

B. Generalized Mutual Exclusion Constraints (GMECs)

This section recalls the problem of enforcing GMECs on PNs [31]. In synthesis, GMECs impose limitations on the weighted sum of markings in a place subset, resulting in a supervisor that specifies a state feedback control law preventing the net from reaching a given set of forbidden markings from the initial marking. Advantages of representing a controller via GMECs are that the closed loop system can be analysed as a whole using PN techniques and tools, and the control action computation is fast, since it does not require any separate computation.

Let $\langle TPN, \mathbf{M}_0 \rangle$ be a TPN system, whose set of reachable markings is $R(TPN, \mathbf{M}_0)$. Assume that a set of legal markings is given and consider the basic control problem of designing a supervisor that restricts the reachability set of the closed loop system to its intersection with the legal marking set. The legal marking set may be expressed by a set of n_c GMECs. In particular, a GMEC is a couple (\mathbf{l}, H) where $\mathbf{l}: P \rightarrow \mathbf{Z}^m$ is a $1 \times m$ weight vector, $H \in \mathbf{Z}$ and \mathbf{Z} is the set of integer numbers.

A set of GMECs (\mathbf{L}, \mathbf{H}) , with $\mathbf{L} = [l_1^T \ l_2^T \ \dots \ l_{n_c}^T]^T$ and

$\mathbf{H} = [H_1 \ H_2 \ \dots \ H_{n_c}]^T$, defines the *legal marking set* $M(\mathbf{L}, \mathbf{H}) =$

$\left\{ \mathbf{M} \in \mathbf{N}^m \mid \mathbf{L}\mathbf{M} \leq \mathbf{H} \right\}$. The support of \mathbf{L} is the set

$Q_L = \{p \in P \mid \mathbf{L}(\cdot, p) \neq 0\}$. A controlling agent, called

supervisor, must ensure that the forbidden markings will not be reached, then the set of legal markings under control is $M_C(\mathbf{L}, \mathbf{H}) = M(\mathbf{L}, \mathbf{H}) \cap R(TPN, \mathbf{M}_0)$.

If all transitions are controllable (i.e., they may be disabled by the supervisor), the TPN controller enforcing (\mathbf{L}, \mathbf{H}) has incidence matrix $C_c \in \mathbf{Z}^{n_c \times n}$ given by [31]:

$$C_c = -\mathbf{L}\mathbf{C} \quad (5)$$

and the initial marking of the controller $\mathbf{M}_{c0} \in \mathbf{N}^{n_c}$ is:

$$\mathbf{M}_{c0} = \mathbf{H} - \mathbf{L}\mathbf{M}_0. \quad (6)$$

The controller exists iff the initial marking is legal, i.e., $\mathbf{H} - \mathbf{L}\mathbf{M}_0 \geq \mathbf{0}$. Such a controller is maximally permissive, i.e., it prevents only transition firings that yield forbidden markings. The control net has n_c control places, called *monitor places* while no transition is added to the controlled net.

IV. TIMED PETRI NET MODELING OF INTERMODAL FREIGHT TRANSPORT TERMINALS

The IFTTs modelling framework employs a modular bottom-up approach. In particular, the TPN representing the terminal is made of subnets, each modelling the sequence of operations on containers in a particular subsystem. Hence, each subnet behaves as a distinct DES interacting with the others by interfacing nets. We consider the following subsystems constituting an intermodal terminal [29], [50]:

- 1) highway;
- 2) tollbooth;
- 3) railway;
- 4) maritime/river port or airport;

- 6) access road;
- 7) parking or yard storage area;
- 8) customs;
- 9) ITUs maintenance area.

The above nine subsystems which may be duplicated and/or combined to form a complete IFTT are complemented by the following two modules that allow the IFTT control:

- 10) opening/closing of an IFTT subsystem;
- 11) checkpoint.

In the proposed TPNs framework, places represent resources and capacities or conditions, transitions model inputs, flows and activities into the terminal, and tokens represent ITUs or the vehicles on which they are transported.

Before describing in detail each subsystem, we clarify that the IFTT bottom-up modeling framework based on TPNs employs three fundamental structures: the IFTT Subnet (IFTTS), the Open IFTT Subnet (OIFTTS), and the Routing Net (RN). In particular, each of the above listed IFTT subsystems is modeled by a TPN module, i.e., an IFTTS, which is to be interconnected with others by way of its transitions that model the inflow and outflow of vehicles into and out of the subsystem and are hence called communication transitions. Moreover, from each IFTTS we define an Open IFTT Subnet, which is a place-bordered net obtained extending the IFTTS with at least one source and/or one sink place, respectively in input and output to the IFTTS communication transitions, allowing the vehicles to be routed to other subsystems. The routing is obtained by interconnecting different OIFTTSs by a RN, so that the TPN complete model of the terminal is attained. Hence, each RN connects with at least one immediate transition the source and sink places of two or more OIFTTS modeling the subsystems among which there is a flow of vehicles. In this way, the decision maker may easily combine the TPN subsystems to represent the flow of vehicles in the larger system, eventually modifying some of their features - i.e.: changing weights of some arcs, modifying the initial marking of the subnet, deleting or adding places or transitions, duplicating nets in a single subsystem (in the case of multiple resources), changing a deterministic transition into a stochastic one or vice-versa.

More formally, the IFTTS is the basic element of the framework and is a $TPN = (P, T, \mathbf{Pre}, \mathbf{Post}, \mathbf{F})$ modeling the functioning of a specific subsystem of the IFTT, considered disconnected from the others. Given a particular IFTTS, an OIFTTS is a place-bordered extension of the IFTTS defined as a 9-tuple $(P, T, \mathbf{Pre}, \mathbf{Post}, \mathbf{F}, P_i, P_o, \mathbf{Pre}', \mathbf{Post}')$, where:

1. $\{P, T, \mathbf{Pre}, \mathbf{Post}, \mathbf{F}\}$ is an IFTTS;
2. P_i is the set of added source places, i.e., $\forall p \in P, \bullet p = \emptyset, P_i \cap P = \emptyset$;
3. P_o is the set of added sink places, i.e., $\forall p \in P, p \bullet = \emptyset, P_i \cap P_o = \emptyset, P_o \cap P = \emptyset$;
4. $\mathbf{Pre}': P_i \times T \rightarrow \mathbf{N}^{m \times n}$, $\mathbf{Post}': P_o \times T \rightarrow \mathbf{N}^{m \times n}$, are the *Pre* and *Post Incidence* sub-matrices for source and sink places;
5. $P_i \cup P_o \neq \emptyset$.

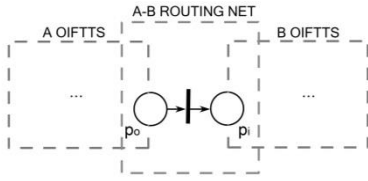

Fig. 1. A-B Modular TPN.

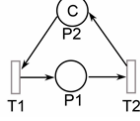

Fig. 2. Highway portion subnet model.

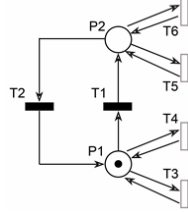

Fig. 3. Tollbooth subnet model.

Moreover, given two OIFTTs $TPN_1=(P_1, T_1, \mathbf{Pre}_1, \mathbf{Post}_1, \mathbf{F}_1)$ with sink place p_o and $TPN_2=(P_2, T_2, \mathbf{Pre}_2, \mathbf{Post}_2, \mathbf{F}_2)$ with a source place p_i such that $T_1 \cap T_2 = \emptyset$, the flow of vehicles from TPN_1 to TPN_2 may be easily modeled by a RN duplicating the border places and connecting them via an immediate transitions, i.e., by a net $TPN_3=(P_3, T_3, \mathbf{Pre}_3, \mathbf{Post}_3, \mathbf{F}_3)$ that is a place-bordered TPN with:

1. $P_3=\{p_o, p_i\}$;
2. $T_3=\{t_r\}$ with $\bullet t_r = \{p_o\}$, $t_r \bullet = \{p_i\}$;
3. $\mathbf{F}_3(t_r)=0$.

Figure 1 represents an example of two OIFTTs A and B modeling two IFTT subsystems and connected by a RN. The OIFTT labeled A has a border sink place p_o that is added to the IFTT modeling the terminal subsystem, while the OIFTT labeled B is obtained adding border place p_i to its subsystem. The two subnets are connected by the A - B RN, duplicating the border places p_o and p_i and including an immediate transition t_r . The tokens flowing in the modular TPN of Fig. 1 represent ITUs moving between the two subsystems A and B .

Generalizing, a RN is a TPN containing immediate transitions each serving as routing interface between the border places of two or more OIFTTs.

The IFTTs modeling the terminal subsystems are detailed in the following sections. For each IFTT, we depict in grey the communication transitions, to which border places may be attached to connect the subsystem to others.

A. Highway

These subnets model the highways through which straight trucks or semi-trailer trucks access/leave the terminal. We recall that trucks can be classified as either straight or articulated vehicles [50]. A straight truck is one in which all axles are attached to a single frame. An articulated vehicle is one that consists of two or more separate frames connected by suitable couplings. A semi-trailer truck is an articulated

vehicle composed by a towing engine called tractor and one or more semi-trailers carrying freight. Figure 2 shows the simple model of a highway portion, where place P_1 indicates the presence of the transportation means, P_2 the highway capacity C (i.e., the maximum number of transportation means that it can accommodate), and exponential transitions T_1 and T_2 are the two communication transitions (depicted in grey) that respectively represent the incoming and outgoing flows and as such allow the combination of the subnet with others.

B. Tollbooth

These subnets model the arrival of vehicles to the IFTT from a tollbooth. Figure 3 represents the tollbooth subnet, with its flows differentiated on the basis of working days and holidays, and on the kind of transportation means. Place P_1 represents arrivals in working days, P_2 arrivals in holidays. Moreover, deterministic transition T_1 (T_2) represents the flow of hours at working (holiday) days. Exponential transition T_3 (T_5) models the arrivals of semi-trailer trucks during working days (holidays), while T_4 (T_6) represents the arrivals of straight trucks during working days (holidays). These four transitions are the subsystem communication transitions. Finally, note that, if different traffic conditions are present every day, it is sufficient to replicate the set given by P_1 , T_1 , T_3 and T_4 for each day of the week.

C. Railways

These subnets model the presence of a dedicated railway system servicing the terminal to deliver or to allow the departure of ITUs. Figure 4a shows a railway line arriving at the intermodal terminal, with trains delivering ITUs and/or straight trucks. Place P_1 indicates the presence of a train and P_2 its absence. Transition T_1 models the activity hours of the train, T_2 the hours of absence of the train, T_3 (communication transition) the average time of arrivals, and x is the number of ITUs or straight trucks at each arrival. As an alternative, Fig. 4b illustrates the case of trains carrying ITUs and/or vehicles in both incoming and outgoing directions. Given the train load plan, it is necessary to model its maximum capacity. Hence, P_1 indicates the presence of a train, P_2 its absence, P_3 the loaded cargo, P_4 the train capacity C (the maximum number of ITUs that it can accommodate). Moreover, T_1 models the activity hours of the train, T_2 the hours of absence of the train, T_3 the average time of arrivals, T_4 (communication transition) the average time for loading/unloading a cargo. Similarly to Fig. 4a, we can model a railway subnet with only outgoing ITUs: we skip reporting the model for the sake of brevity. Moreover, in case of multiple rail lines with different destinations or in case of different incoming rates during the week, it is sufficient to connect multiple subsystems similar to that in Fig. 4b, with different values of the average time of the arrivals for the incoming loads. Finally, in Fig. 4c we represent the possibility of modeling the loading/unloading phase separately. In particular, the loading of ITUs on the train is enabled only after the unloading phase is ended. Accordingly, P_1 represents the presence of a train in the terminal, P_2 its absence, P_3 the capacity y of the train, P_4 the

unloading of the train, T_1 the sojourn time of the train in the terminal, T_2 the absence time of the train from the terminal, T_3 (communication transition) the average unloading time for x ITUs, T_4 (communication transition) the average time for loading an ITU. T_5 allows emptying P_3 at train departures.

D. Maritime or river ports and airports

Maritime and river ports, as well as airports, can be represented by the same subsystem, shown in Fig. 5, with different meanings of places and transitions.

In case of maritime (river) ports, the model represents the transit, docking, sojourn, and load of a ship (barge), to be connected to the intermodal platform. Place P_1 indicates the absence of the vessel in the port, P_2 the docking of the vessel, P_3 its presence, P_4 the loaded cargo, P_5 the capacity C of the vessel. Further, T_1 is the required docking time, T_2 the dwell time in port, T_3 the sailing time, T_4 the enabling for load/unload, T_5 (communication transition) the loading/unloading time.

Similarly, for airports, Fig. 5 represents the landing, length of stay and loading of an aircraft in the terminal. In such a case P_1 indicates the absence of the aircraft in the airport, P_2 the landing of the aircraft, P_3 its presence, P_4 the loaded cargo, P_5 the capacity C of the aircraft, T_1 is the required time for landing, T_2 the dwell time in airport, T_3 the flight duration, T_4 the enabling for loading/unloading, T_5 the average time for loading/unloading. As in the railway net, even for seaports, fluvial ports and airports, in case of multiple lines with different destinations or differences within the week, it is sufficient to connect similar subsystems, with different values of the average time of the arrivals for the incoming loads.

E. Access road

These subnets model the truck access roads to terminals. In particular, Fig. 6a models the entrance into the terminal of straight trucks: place P_1 indicates the entrance of transportation means in the terminal, and P_2 its capacity C , transition T_1 (communication transition) the average arrival time and T_2 (communication transition) the average closing time.

In case of semi-trailer truck flows, the model is different from that in Fig. 6a, since trucks have to be disassembled for their ITUs to be transshipped. The corresponding alternative subnet model is shown in Fig. 6b, where place P_1 indicates the waiting ITUs, P_2 the waiting tractors, P_3 a cargo waiting for loading, P_4 the ITUs to be reassembled with the corresponding truck, P_5 (P_6) enables (inhibits) the freight to leave the terminal on the same arrival day, P_7 models the ITUs that will exit from the terminal the next day, P_8 the capacity C of the waiting area. T_1 (communication transition) is the average arrival time, T_2 the average waiting time, T_3 the average time for loading/unloading a cargo (communication transition), T_4 is the average arrival time both for ITUs and tractors available for reassembly, T_5 and T_6 model the delay times for the exit of semi-trailers, T_7 is the enabling for the immediate exit, T_8 (communication transition) is the average exit time of ITUs and tractors.

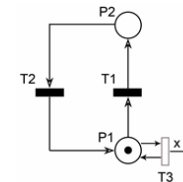

Fig. 4a. Railway subnet model: only incoming ITUs.

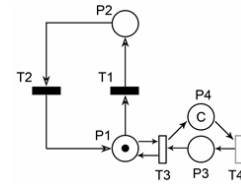

Fig. 4b. Railway subnet model: incoming and outgoing ITUs.

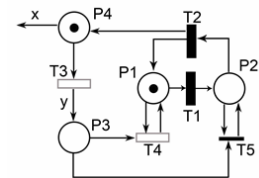

Fig. 4c. Railway subnet model: incoming and outgoing ITUs with separate load/unload.

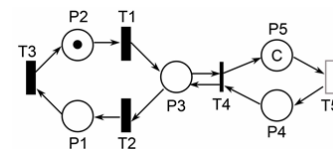

Fig. 5. Seaport, river port or airport subnet model.

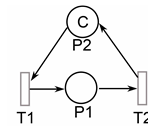

Fig. 6a. Access road subnet model for straight trucks.

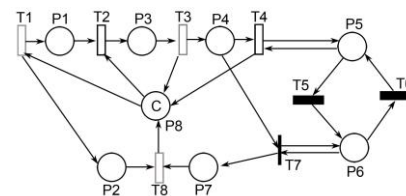

Fig. 6b. Access road subnet model for semi-trailer trucks with reassembly.

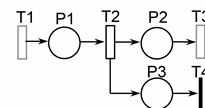

Fig. 6c. Access road subnet model for semi-trailer trucks leaving ITUs.

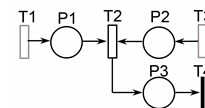

Fig. 6d. Access road subnet model for semi-trailer trucks loading ITUs.

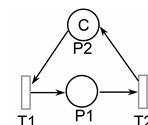

Fig. 7. Parking or yard storage area subnet model.

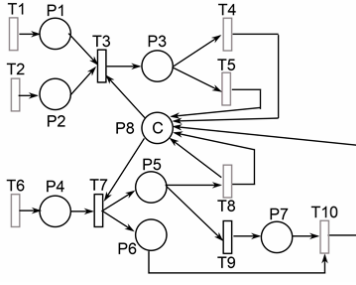

Fig. 8. Customs area subnet model.

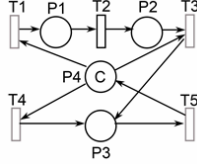

Fig. 9. ITUs maintenance area.

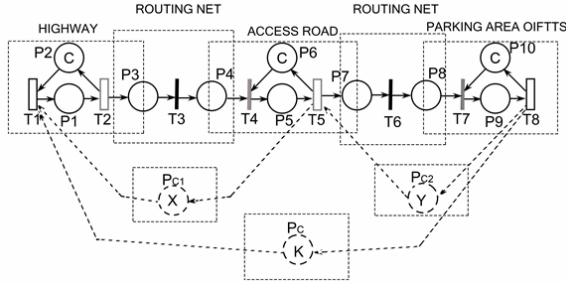

Fig. 10. Example of TPN model of IFTT.

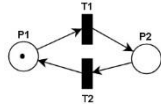

Fig. 11a. Opening/closing for hours subnet model.

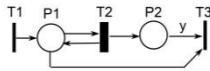

Fig. 11b. Opening/closing for days subnet model.

When ITUs are left in the terminal by the semi-trailer trucks but tractors do not wait in the terminal for the next cargo, it is possible to use the simpler subnet in Fig. 6c instead of the previous nets: place P_1 indicates the presence of the full semi-trailer truck in the terminal, P_2 the ITU left by the truck, P_3 the tractor leaving the terminal, transition T_1 (communication transition) average arrival time for the transportation means, T_2 the disjunction of the tractor from the ITU, T_3 (communication transition) average ITU's transportation time to the next subsystem, T_4 exit of the tractor. In a similar way, it is also possible to represent tractors that arrive in the terminal and load ITUs to deliver. This case is modelled in Fig. 6d, where P_1 represents incoming tractors without load, P_2 ITUs to be delivered, P_3 outgoing tractors with ITUs, T_1 (communication transition) the average arrival time of incoming tractors, T_2 the tractor connection to the ITU, T_3 (communication transition) the average arrival time of ITUs available to be delivered, T_4 semitrailers leaving the terminal.

F. Parking or yard storage area

External parking areas (for waiting trucks) and yard parking areas (to store ITUs) are modelled as in Fig. 7, where P_1 indicates the entrance in the area, P_2 its capacity C , T_1 (communication transition) is the average arrival time and T_2 (communication transition) the average exit time.

G. Customs

These subnets model the presence of customs in the IFTT and are represented in Fig. 8. The subnet inflows may refer to ITUs, straight trucks, or semi-trailer trucks. Each item is inspected by the customs and sent to the subsequent transport mode, or, in case of customs rejection, it is returned to the sender via the same means. Hence, P_1 (P_2) models the inspection of ITUs (straight trucks), P_4 the inspection of ITUs carried on semi-trailer trucks, P_6 the waiting tractors, P_7 the rejected ITUs and straight trucks, P_8 the capacity C of the custom area. Moreover, transition T_1 (T_2) is the average arrival time of ITUs (straight trucks), T_3 the average inspection time, T_4 the average exit time of accepted ITUs and straight trucks, T_5 the average exit time of rejected ITUs and straight trucks, T_6 the average arrival time of semi-trailer trucks, T_7 the average inspection time for semitrailers, T_8 the average exit time of accepted ITUs carried on semi-trailer trucks, T_9 the average exit time of rejected ITUs carried on semi-trailer trucks, T_{10} the average exit time of reassembled semi-trailer trucks. Note that $T_1, T_2, T_4, T_5, T_6, T_8, T_{10}$ are all communication transitions.

H. ITUs maintenance area

These subnets model the terminal area dedicated to ITU maintenance. This area can be modelled as in Fig. 9, where we consider the possibility of executing either only routine maintenance or both routine and special maintenance. Hence, place P_1 represents ITUs waiting for special maintenance, P_2 ITUs under special maintenance, P_3 ITUs waiting for ordinary maintenance, P_5 ITUs under ordinary maintenance, P_4 the number of resources (C) available for the maintenance area. Moreover, transition T_1 models the average arrival time of ITUs in the special maintenance area, T_2 the average time for the special maintenance, T_3 the average waiting time for routine maintenance after the special one, T_4 the average arrival time of ITUs for routine maintenance, T_5 the average exit time of the ITUs from the maintenance area. Here T_1, T_3, T_4, T_5 are all communication transitions.

I. Example of TPN model of an IFTT

Figure 10 (solid lines only) shows the TPN model of a simple IFTT, including the last miles of a highway, an access road and a parking area. These are first modeled by the IFTTS respectively represented in Figs. 2, 6a and 7. Hence, they are extended to obtain the matching OIFTTs, respectively by adding a sink place p_3 (highway), a source place p_4 and a sink place p_7 (access road) and a source place p_8 (parking area).

The combination of the three subnets is allowed by two RNs and by the corresponding immediate transitions t_3 and t_6 .

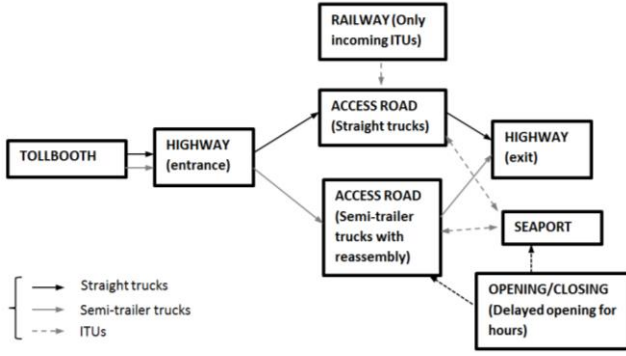

Fig. 12. Scheme of the literature example [23].

Finally, we remark that in the access road and parking area subsystems the source transitions t_4 and t_7 are both immediate to allow the average arrival time of vehicles in the subnets being equal to the average exit time of the transportation means of the preceding subnets, i.e. t_2 and t_5 .

J. Opening/closing of an IFTT subsystem

The cyclical opening/closing of any previously described IFTTS can be managed considering a subnet that allows controlling hours or days of activity/inactivity. Figure 11a depicts the model of the opening and closing of an IFTTS, specifying the hours of activity and inactivity of the terminal or of any external parking area. In this case, place P_1 (P_2) indicates when the subsystem is active (idle), and transition T_1 (T_2) models the activity (idling) time. As an alternative, Fig. 11b shows the opening/closing of a subsystem depending on days, where P_1 represents the passing of a working/non-working day, P_2 is the counter of the number of working/non-working days, P_3 models the presence/absence of the means in the subnet, y (the weight of the arc from P_2 to T_3) is the number of working/non-working days, T_1 is the start of activity/inactivity, T_2 is the duration of the day, and finally T_3 is the end of activity/inactivity.

K. Checkpoint

To impose constraints on the IFTT behavior, checkpoints can be installed and modeled by GMECs controlling the TPN dynamics. As seen in Section III.B, the GMEC can be regarded as a supervisor specifying a state feedback control law. For instance, Fig. 10 shows the case in which three checkpoints (dashed lines) are added to the IFTT example (solid lines) described in subsection IV.I. The number of incoming trucks is controlled by the control places P_{C1} (between the highway and access road), P_{C2} (between the access road and parking area), and P_{C3} (between source and sink transitions of the system). The control laws are:

$$M(p_1) + M(p_3) + M(p_4) + M(p_5) \leq M(p_{c1}), \quad (7)$$

$$M(p_7) + M(p_8) + M(p_9) \leq M(p_{c2}), \quad (8)$$

$$M(p_1) + M(p_3) + M(p_4) + M(p_5) + M(p_7) + M(p_8) + M(p_9) \leq M(p_{c3}), \quad (9)$$

V. CASE STUDIES

To evaluate its effectiveness and ease of application, the proposed model is applied to two IFTTs: the first is an example from the literature [23]; the second is a real case study that is described also in [19] and [20]. The TPN models are simulated in MATLAB using the HYPENS tool [46], and the performance indices are evaluated by multiple replications of simulation runs of 8,760 time units (one year, considering one hour per time unit) each. To evaluate the case studies behavior, we take into account two kinds of indices: the utilization of the critical IFTT areas and the throughput of the IFTT subsystems interconnections.

A. A literature example

We apply the modelling framework to an intermodal terminal located in Trieste, Italy [23]. The IFTT includes eight subsystems (Fig. 12). Within the terminal, straight and semi-trailer trucks circulate, modelled as tokens of the TPN moving on two separate lines with the same capacity. The first module of the IFTT in Fig. 12 is the tollbooth (Fig. 3), differentiating the entrance frequency based on the vehicle type and day (weekdays/holidays). The highway subsystem (Fig. 2) provides the trucks entrance into/exit from the terminal, while the railway subsystem (Fig. 4a) provides the entrance for straight trucks, whose arrival is differentiated between weekdays and holidays; hence, this subnet is obtained by joining two different models. The seaport subsystem (Fig. 5) manages the arrival, departure, docking, loading and unloading of a ship that can carry both straight trucks and ITUs deposited by semi-trailer trucks. Finally, the terminal includes access roads, differentiated according to the type of trucks (Figs. 6a and 6b), and an opening/closing subnet (Fig. 11a). Hence, the TPN model of the IFTT in Fig. 12 is determined connecting each TPN subsystem, obtaining the TPN in Fig. 13, where each dashed box indicates a subsystem.

Moreover, the TPN model includes seven RNs that allow routing the vehicles between the different terminal subsystems. Note that in the opening/closing subsystem of Fig. 13, with respect to Fig. 11a we add a transition (T_{61}) to create a delay between the terminal opening and the start of the embarkation on the vessel. This transition is enabled only at the initial marking of the simulation by place P_{65} . In addition, places P_{17} (modelling the capacity of access road for straight trucks) and P_{42} (modelling the capacity of access road for semi-trailer trucks) are respectively assigned a capacity of $A=40$ and $B=100$ vehicles. Table I shows the firing times (in hours) and the meaning of the deterministic and stochastic transitions that model the flows of means within the TPN in Fig. 13: values are assigned based on the terminal data in [23].

Implementing the net in Fig. 13 in HYPENS [46] with replications of 8,760 time units each, we obtain a computation time for each replication of less than 8 minutes on a PC with an Intel Core 2 Duo - 2.80 GHz processor and 4 Gb of RAM. Hence, the approach can be applied to even larger and more complex IFTTs.

We evaluate the terminal behavior by the following performance indices [41], [52].

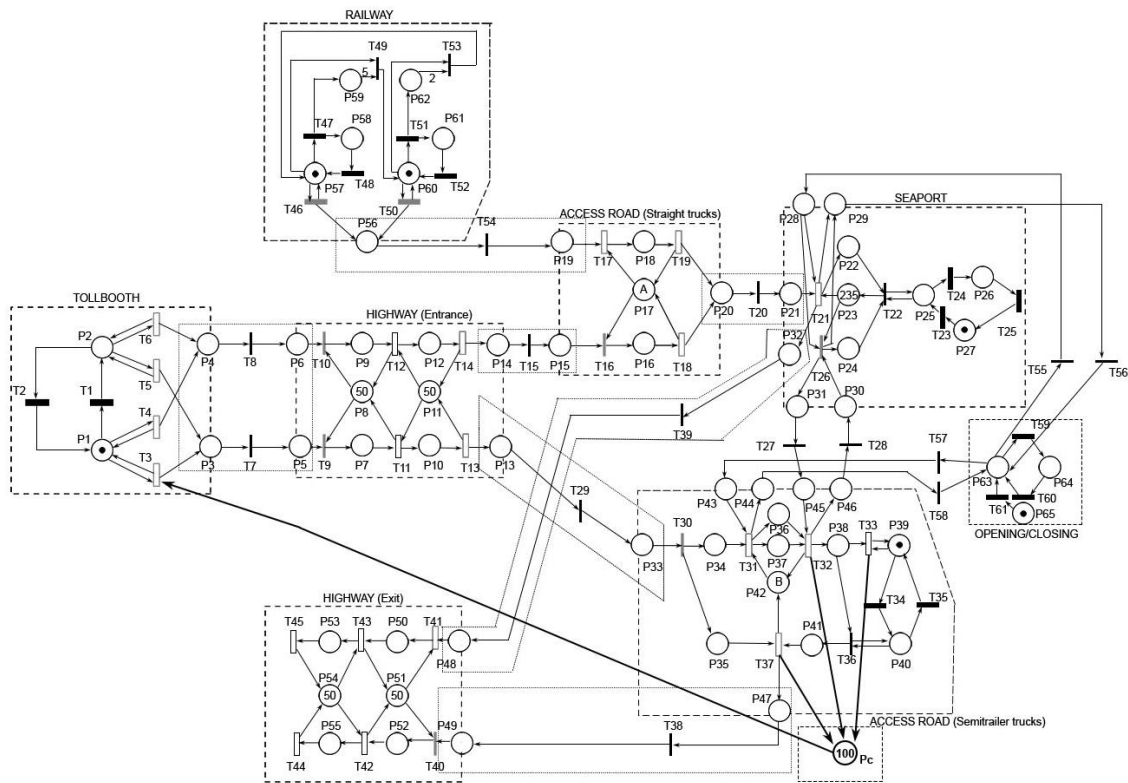

Fig. 13. TPN model of the literature example in Fig. 12 [23].

TABLE I
MEANING AND FIRING TIMES OF TRANSITIONS IN THE TPN OF FIG. 13.

Transition	Description	Firing time [h]
T ₁	Weekdays	120.000
T ₂	Holydays	48.000
T ₃ , T ₄	Arrival of semi-trailer (straight) trucks on weekdays	0.590 (0.210)
T ₅ , T ₆	Arrival of semi-trailer (straight) trucks on holidays	0.570 (0.290)
T ₁₁ , T ₁₂ , T ₁₃	Flows of vehicles through the highway	0.170
T ₁₄ , T ₄₂ , T ₄₃ , T ₄₄ , T ₄₅		
T ₂₁	Embarkation/disembarkation of straight trucks	0.017
T ₃₁	Average embarkation time for semi-trailer trucks	0.001
T ₃₂	Embarkation/disembarkation of semi-trailer trucks	0.220
T ₃₃	Semi-trailer trucks exiting the terminal	0.670
T ₃₄	Tractors waiting in the terminal	23.500
T ₃₅	Reassembling tractors/cargo	0.900
T ₃₇	Departure of semi-trailer trucks	0.210
T ₆₁	Opening terminal delay	1.000
T ₅₉	Opening time of the terminal	5.500
T ₆₀	Closing time of the terminal	18.500
T ₂₃	Presence of vessel in the seaport	0.500
T ₂₄	Shipping time	17.000
T ₂₅	Docking	6.500
T ₁₇	Transition of straight trucks from rail to terminal	0.110
T ₁₈ , T ₁₉	Straight trucks entering the port	0.100
T ₄₆ , T ₅₀	Arrival of trains	2.000
T ₄₇	Presence of train in the railway on weekdays	7.000
T ₄₈	Absence of train in the railway on weekdays	17.000
T ₅₁	Presence of train in the railway on holidays	4.000
T ₅₂	Absence of train in the railway on holidays	20.000
T ₄₁	Straight trucks exiting the terminal	0.100

TABLE II
PERFORMANCE EVALUATION OF THE TPN OF FIG. 13.

Scenarios	FC ₁	FC ₂	FC ₃	Tr(T ₁₃)	Tr(T ₁₄)	Tr(T ₂₁)	Tr(T ₃₁)	Run time [s]
As-is	19	3.21	3	0.03	0.07	6.28	0.06	434
1	143	3.98	3.50	0.03	0.07	6.28	0.06	648
2	6.8	382	38.90	1.70	3.80	7.90	3.80	1618
3	163	384	49	1.70	3.80	3.88	3.82	1605
4	16.04	13.82	15.26	0.36	0.79	5.66	0.79	748

First, we use the average free capacity of the IFTT, i.e., the average number of straight (semi-trailer) trucks FC₁ (FC₂) that may still be accommodated in the terminal, i.e., the marking of P₁₇ (P₄₂). Second, we evaluate the average free capacity FC₃ of the last portion of the entrance highway (the marking of P₁₁), i.e., the average number of vehicles that may still enter it. Third, we estimate the average throughput Tr(T_i) of suitable stochastic transitions T_i ∈ T_E, i.e., the average number of fires per time unit of T₁₃, T₁₄, T₂₁, T₃₁ (chosen since they respectively represent the passage of vehicles from the highway to the terminal and from the terminal to the seaport). The performance indices are obtained from 1000 independent replications with a 95% confidence. At each replication, the delays of the stochastic transitions are randomly generated with respect to the associated probability distribution. The resulting half width of the confidence interval is about 1.5% in the worst case. This confirms the accuracy of the estimates, although an increased number of replications would provide a narrower confidence interval. The choice of a high number of replications is particularly useful in case of real time simulation for decision support at the operational level, but it is of course determined by a compromise choice depending on the model complexity and the resulting simulation time.

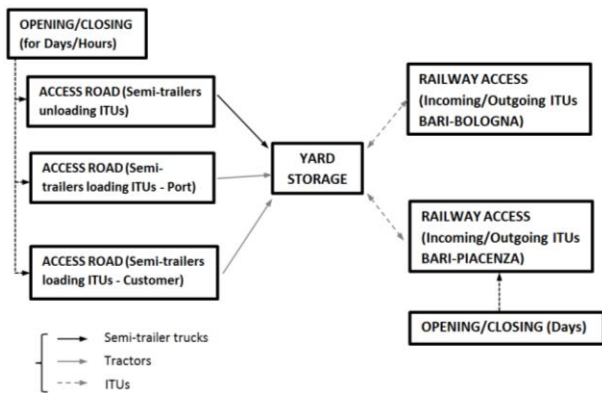

Fig. 14. Scheme of the real case study.

Table II shows the simulation results. In particular, the Table collects in each rows the results corresponding to the as-is situation and four alternatives (Scenarios 1 to 4): the first three alternatives provide structural actions by creating new parking areas, while in the last scenario we consider ICT tools that can avoid oversaturation, through the exchange of information among the logistic actors, thus resulting in lower investments. Moreover, each column of Table II reports the obtained values of the defined IFTT performance indices, while the last column shows the corresponding run time.

Analyzing the as-is scenario (first row of Table II), it is apparent that the access road for straight and semi-trailers trucks is oversaturated, which leads to congestion of the IFTT. Indeed, the relative free capacities FC_1 and FC_2 of P_{17} and P_{42} in Fig. 13 have very low average values, just like the free capacity of the last portion of the highway FC_3 in P_{11} . Obviously, this also affects the average number of vehicles passing from the highway to the terminal and then to the port, as evidenced by the low throughput values (columns 5 to 8).

To overcome the disadvantages of the as-is scenario, we consider four different alternative solutions: the increase of the capacity of P_{17} from $A=40$ to 190 (Scenario 1); increasing the capacity of P_{42} from $B=100$ to 450 (Scenario 2); increasing both these capacities by setting $A=190$ and $B=450$ (Scenario 3); the insertion of a supervisor, by means of a GMEC (shown in Fig. 13 with bold lines) keeping the as-is capacities (Scenario 4).

The evaluated indices reported in Table II (last four rows) show that, by increasing the access roads capacities, the flow of vehicles within the system becomes more regular and congestion is avoided. In particular, in Scenario 1, considering the increase only of the straight trucks access road capacity (A in Fig. 13), the performance indices still highlight an oversaturation of the semi-trailer access road (FC_2 equal to 3.98 in Table II) and consequently of the incoming highway connected to the IFTT (FC_3 equal to 3.50). This leads to a high value of the average free capacity of the straight trucks access road: the area seems free, but this depends only on the slowing down of the highway flow.

In scenario 2 we increase the semi-trailer trucks access road capacity (B in Fig. 13). This results in the decongestion of the access roads and of the incoming highway, although the capacity of the straight trucks area remains too low. Hence,

the best results are obtained in Scenario 3, i.e., by increasing the capacities of both P_{17} and P_{42} in Fig. 13 (see second-last line of Table II). Scenario 4 considers the control by a checkpoint of the entrance during weekdays of semi-trailer trucks into the terminal, using a monitor place between the highway tollbooth and the semi-trailer access road. We assume that ICT tools allow exchanging information among the logistics actors. Hence, it is assumed that by a suitable information, provided to the semi-trailer trucks owners, the semi-trailer trucks flow is forbidden until the highway of the terminal and the parking area of the terminal are no longer oversaturated, limiting pollution, decreasing travel costs and increasing road safety. Accordingly, the ICT control law is realized by preventing the TPN from evolving towards forbidden states, i.e., saturated access road and highway for semi-trailer trucks. Since these restrictions on the system behavior are logical predicates that do not depend on the time evolution, the control problem can be formulated using GMEC, i.e., constraining the weighted sum of markings in a place subset, as follows:

$$M(p_3) + M(p_5) + M(p_7) + M(p_{10}) + M(p_{13}) + M(p_{33}) + M(p_{34}) + M(p_{36}) + M(p_{37}) + M(p_{38}) \leq B \quad (10)$$

The constraint is imposed including in the net a control place, which has as initial marking $M(P_C)=B$. This enables the semi-trailer trucks to flow in the highway, according to the free space still available in the relative access road, avoiding congestion (last row of Table II).

B. A real case study

The second case study concerns a real intermodal inland rail-road terminal located in Bari (Southern Italy) at the GTS - General Transport Service S.p.A. company, a leader in intermodal freight transport in Italy and Europe, owning about 1,800 containers of different types and 280 rail wagons. The current management of the logistics system is considered and some possible improvements are proposed.

In Fig. 14 a scheme of the IFTT is presented. Semi-trailer trucks and trains circulate in the IFTT, the former through access roads, the second by a dedicated railway line. Trucks and trains transport ITUs that are stored and made available for the next transport mean in a dedicated yard storage area. During the week, the terminal can accommodate trucks from 6.30 a.m. to 6.30 p.m., while on Sunday the terminal is closed. The company manages semi-trailer trucks traffic as follows: vehicles that carry ITUs to the rail destinations of Piacenza and Bologna (Italy); vehicles that load ITUs to deliver in the port with destination Patras (Greece); vehicles that pick up ITUs to load from (deliver to) the initial (final) customer.

The rail traffic is classified into: trains from/to Piacenza, with capacity $C_{TP}=34$ ITUs, and trains from/to Bologna, with capacity $C_{BT}=20$ ITUs. Trains from/to Bologna circulate all week on alternate days, arriving in Bari at 7.30 a.m. and staying until 5.30 p.m. (the trains return to the terminal after 38 hours). Trains from/to Piacenza, instead, arrive every day at 7.30 a.m. and stay till 5.30 p.m., while there are no arrivals on Sunday. The ITUs delivered to the IFTT by road or rail are

stacked in a yard storage with capacity $C_{YS}=250$ ITUs.

1) The terminal TPN model

This section presents the TPN model describing the IFTT in Fig. 14. The TPN system $\langle TPN, M_0 \rangle$ of Fig. 15 with $TPN=(P, T, Pre, Post, F)$ models the structure and the dynamic evolution of the IFTT under the current management that is here called case as is. The TPN system in Fig. 15 consists of the necessary subnet models described in Section IV, connected in an appropriate manner. The TPN digraph elements are specified as follows. The place set is $P=P_R \cup P_C \cup P_F$: set P_R models the system resources (i.e., access roads, rail, and GTS terminal); set P_C models the available capacities of the resources; set P_C contains places used to model conditions, to give priority and synchronize the main events of the system (time of day or day of the week, opening/availability and closure/unavailability of resources, etc.). In the TPN model, a token in a place $P_i \in P_R$ represents an ITU, semi-trailer or train in the system, a token in a place $P_i \in P_C$ is an available position in a resource and a token in a place $P_i \in P_F$ represents a condition that is verified. Moreover, the transition set of the net in Fig. 15 is $T=T_S \cup T_D \cup T_I$. Exponential stochastic transitions in T_S model the input of vehicles into the IFTT, their flows and activities. Moreover, set T_D of deterministic timed transitions models the occurrence of deterministic events at particular times of the day, i.e., the terminal opening (transition T_1) and closing events (transition T_2), the weekly closing of the terminal (T_4) the weekly pause of the train arrival/leaving from/to Piacenza (T_{60}), the arrival (T_{51} - T_{56}) and the departure (T_{52} - T_{57}) of the trains, set T_I collects the TPN immediate transitions, i.e., T_3 modelling the start of the closure interval for the terminal, T_5 modelling the end of the closure interval for the terminal, T_{11} - T_{17} - T_{23} modelling the exit of trucks from the terminal, T_{53} - T_{58} reset of the train capacity at every departure, T_{59} - T_{61} start/end of the closure interval for train arrival/departure from/to Piacenza.

Matrices *Pre* and *Post* and the initial marking M_0 of the TPN system in Fig. 15 can be deduced from the edges and the token distribution shown in the figure. In particular, each place $p_i \in P_R$ can accommodate vehicles and, assuming that the system is empty at the initial marking, it holds $M_0(p_i)=0$ for each $p_i \in P_R$. On the other hand, the initial marking of each $p_i \in P_C$ is set equal to the corresponding resource capacity. According to the terminal structure in Fig. 14, the IFTT model in Fig. 15 is formed by suitably connecting using five RNs eight subsystems among the following kinds of IFTTS: 1) access road for semi-trailer trucks unloading ITUs, 2) access road for semi-trailer trucks loading ITUs, 3) yard storage area, 4) railway with separate ITUs load/unload an the opening/closing management; 5) opening/closing of an IFTT subsystem. For each subnet the meaning of places and transitions are those listed in Section IV, and the firing times associated with stochastic and deterministic transitions are given in Table III.

2) Simulation results

The IFTT dynamics is simulated and analysed using the data in Table IV. The aim is studying the system behaviour considering the actual management of the terminal and comparing it with possible scenarios and alternative solutions.

The indices evaluating the IFTT performance are [39], [47]:

- 1) the occupation of the yard storage area, evaluating the number of ITUs in the area, its average value O_{YS} and its maximum value;
- 2) the occupation of access roads, evaluating the number of semi-trailer trucks waiting for loading/unloading ITUs, its average value O_{AR} and its maximum value;
- 3) the average throughput $Tr(T_i)$ or average number of fires per time unit of some stochastic transitions $T_i \in T_S$.

Starting from the actual structure (scenario as-is), the system behavior is evaluated in eight additional scenarios, to test the model capability to represent different situations (see Table IV): in Scenarios 1-2-3 we assume, respectively, an increase of 20-30-50% in the number of empty ITUs exiting the terminal by semi-trailer trucks for subsequent loading of goods; in Scenario 4 the yard storage capacity C_{YS} is increased, from 250 to 375 ITUs; in Scenario 5 times associated to loading/unloading ITUs, i.e. T_{30} , T_{31} , T_{32} , T_{50} , T_{55} , are halved; in Scenario 6 we consider a reduction of 25% of the loading/unloading times of the ITUs (T_{30} - T_{31} - T_{32} - T_{50} - T_{55}); in Scenario 7 the traffic of ITUs is incremented of 100% and the times for loading/unloading ITUs are halved; finally, in Scenario 8 we double the loading/unloading times. The performance indices for each scenario are listed in Tables V and VI. The average occupations O_{YS} , O_{AR1} , O_{AR2} , and O_{AR3} are respectively calculated for the yard storage area P_{33} , for the access road of semi-trailers leaving ITUs in the terminal P_{27} , for the access road of tractors carrying ITUs from terminal to the final customer P_{29} , for the access road of tractors carrying ITUs from terminal to port P_{31} . The occupation maximum values (minimum values are zero) are also in Table V.

Throughputs are calculated for the loading/unloading of ITUs in the yard storage ($Tr(T_{30})$ - $Tr(T_{31})$ - $Tr(T_{32})$) and the loading on trains ($Tr(T_{50})$ - $Tr(T_{55})$).

In the first row of Table V we show the results for the case as-is. Comparing the average value of occupation of the yard storage O_{YS} (28.88 ITUs) with its maximum capacity C_{YS} (250 ITUs), and analyzing the average values of occupation of the access roads O_{AR1} - O_{AR2} - O_{AR3} (which amount to around one vehicle), the system appears not congested, highlighting a good management of the available resources.

In Scenarios 1-2-3 we consider a 20-30-50% increase of the load of goods carried by straight trucks. As a consequence, the values associated with some parameters of the net are adapted to represent the relative Scenario, as reported in Table IV.

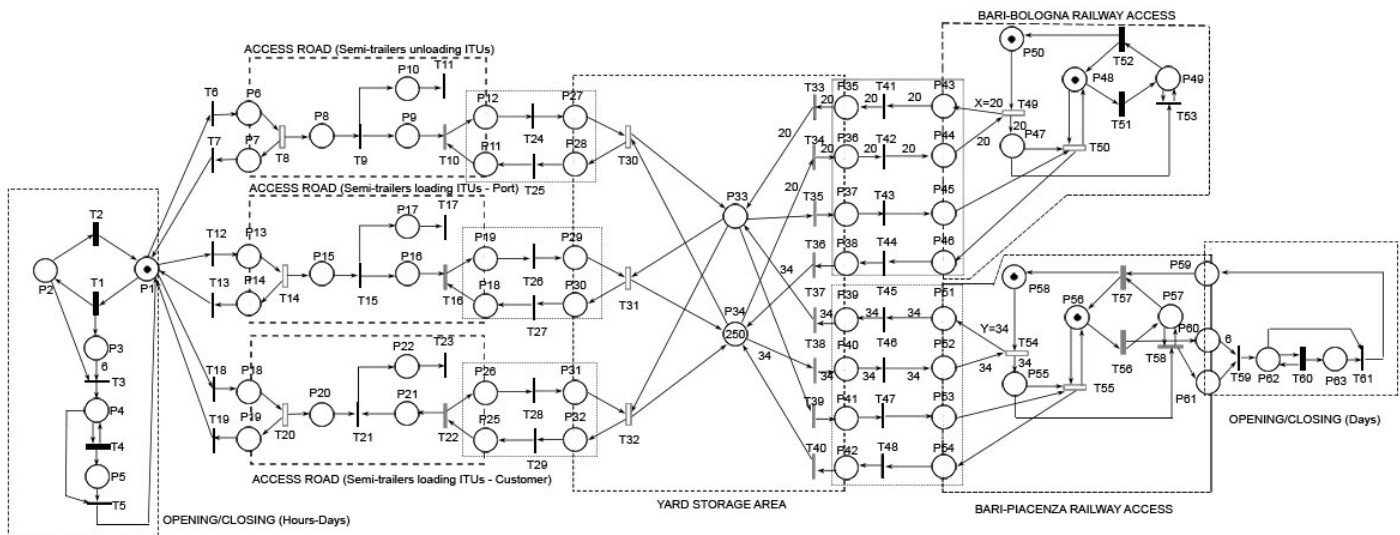

Fig. 15. TPN model of the real case study in Fig. 14.

TABLE III
MEANING AND FIRING TIMES OF TRANSITIONS OF THE TPN IN FIG. 15.

Transition	Description	Firing time [h]
T ₁	Hours of activity of the terminal	12.00
T ₂	Hours of closure of the terminal	12.00
T ₄	Sunday closure	12.00
T ₆	Average arrival time of full semi-trailer trucks, unloading ITUs in the terminal	0.34
T ₇	Average time for ITU unloading	0.13
T ₉	Average arrival time of tractors that load ITUs with destination final customer	0.46
T ₁₀ -T ₁₃	Average time for semi-trailer assembling	0.13
T ₁₂	Average arrival time of tractors that load ITUs with destination port	1.14
T ₁₅	Stay time in terminal of the train Bari-Bologna	10.00
T ₁₆	Absence time in terminal of the train Bari-Bologna	38.00
T ₁₇	Average time for unloading cargo of Bari-Bologna train	2.00
T ₁₈ -T ₂₃	Average time for ITU loading on the train	0.13
T ₂₀	Stay time in terminal of the train Bari-Piacenza	10.00
T ₂₁	Absence time in terminal of the train Bari-Piacenza	14.00
T ₂₂	Average time for unloading cargo of Bari-Piacenza train	3.00
T ₂₆	Weekly pause for Bari-Piacenza train	24.00

In particular, the following IFTT parameters vary: the average number of trucks entering the terminal, i.e., the average interarrival time of trucks in the terminal (T_8 , T_{14} , T_{20} in Fig. 15); the number of ITUs carried by trains (X , Y in Fig. 15); the average time needed for their loading (T_{49} , T_{54}). Note that the capacity of the yard storage area remains equal to 250 ITUs. As reported in Tables V and VI, the system reacts well in the first two situations, i.e. O_{YS} is around one fifth of the maximum capacity (C_{YS}) and the access roads are occupied by at most one vehicle during working hours. When the number of carried ITUs is increased by 50%, the yard storage (O_{YS}) and the access road for semi-trailer trucks with full ITUs (O_{AR1}) become congested, revealing the limitation of the system to manage an increase of the volumes of full ITUs. To

reduce the congestion some alternatives are evaluated. In Scenario 4, the C_{YS} is increased from 250 ITUs to 375 ITUs, but this does not produce any considerable improvement; O_{YS} and O_{AR1} do not show a substantial decrease. In Scenario 5 the times needed for loading/unloading ITUs, i.e., the firing times of T_{30} - T_{31} - T_{32} - T_{50} - T_{55} , are halved, assuming a value of 0.07 hours, with C_{YS} equal to its original 250 ITUs value. In this way, the number of ITUs waiting in yard storage area O_{YS} and the number of semi-trailers waiting for unloading O_{AR1} , drastically decrease. Scenario 6 considers a reduction of 25% of the loading/unloading times of the ITUs (T_{30} - T_{31} - T_{32} - T_{50} - T_{55} equal to 0.1 hours), without modifying C_{YS} , and the system still does not congest. In Scenario 7, the traffic of ITUs is doubled (as shown in Table IV; with regards to T_8 , T_{14} , T_{20} and X , Y) and the times for loading/unloading ITUs are halved (T_{30} - T_{31} - T_{32} - T_{50} - T_{55} equal to 0.07 hours). The obtained performance indices values demonstrate that the terminal can manage well a large increase of ITUs handling (see the relative O_{YS} , O_{AR1} , O_{AR2} , O_{AR3}), but only if the resources needed for the loading/unloading are increased in such a way that the times associated to these activities can be halved. In Scenario 8, we assume a doubling of the loading/unloading times (T_{30} - T_{31} - T_{32} - T_{50} - T_{55} equal to 0.26 hours), to represent a situation in which a technical failure or a shortage of staff occurs. The performance indices show now a congestion of the yard storage area (O_{YS}) and of the access road for full semi-trailer trucks (O_{AR1}), causing difficulties in the management of ITUs carried by trains. The throughputs in all scenarios completely reflect the remarks for each case.

As an example, Fig. 16 (17) represents the evolution under Scenario 3 of the markings of places P_{27} (P_{33}), i.e., the variation over time of the occupation of the first access road, whose average O_{AR1} and peak values are in Table V (the occupation of the yard storage area whose average O_{YS} and peak values are in Table V). The figures show that under this scenario the access road copes with the incoming flows, while the storage area is always congested, so that its occupation is often close to its capacity of 250 vehicles.

Fig. 16. $M(P_{27})$ (occupation of access road) in Scenario 3.Fig. 17. $M(P_{33})$ (occupation of yard storage area) in Scenario 3.

TABLE IV
SCENARIOS FOR PERFORMANCE EVALUATION OF TPN IN FIG. 15.

Sc.	T_8 [h]	T_{14} [h]	T_{20} [h]	T_{49} [h]	T_{54} [h]	X [ITU]	Y [ITU]	C_{YS} [ITU]
As-is	0.34	1.14	0.46	2.00	3.00	20	34	250
1	0.30	1.14	0.38	2.40	3.60	24	41	250
2	0.28	1.14	0.35	2.60	3.80	26	44	250
3	0.25	1.14	0.30	3.00	4.30	30	51	250
4	0.25	1.14	0.30	3.00	4.50	30	51	375
5	0.25	1.14	0.30	1.50	2.25	30	51	250
6	0.25	1.14	0.30	2.20	3.40	30	51	250
7	0.20	1.14	0.23	2.00	3.00	40	68	250
8	0.34	1.14	0.46	3.00	4.50	20	34	250

TABLE V
PERFORMANCE INDICES OF TPN IN FIG. 15 – AVG. AND MAX OCCUPATION.

Sc.	O_{YS} [ITUs]	Max $M(P_{33})$	O_{AR1} [veh]	Max $M(P_{27})$	O_{AR2} [veh]	Max $M(P_{29})$	O_{AR3} [veh]	Max $M(P_{31})$
As-is	28.88	115	0.67	9	0.30	9	1.24	24
1	48.49	174	0.77	113	0.21	6	1.16	23
2	54.20	200	0.86	9	0.20	9	1.03	34
3	240.94	250	9.20	72	0.16	4	0.85	12
4	339.60	370	2.35	30	0.16	4	0.82	10
5	16.75	125	0.46	8	0.52	11	2.38	45
6	33.73	180	0.71	12	0.20	7	1.77	47
7	26.27	170	0.59	8	0.16	6	1.88	47
8	234.38	250	8.17	68	0.24	5	0.83	11

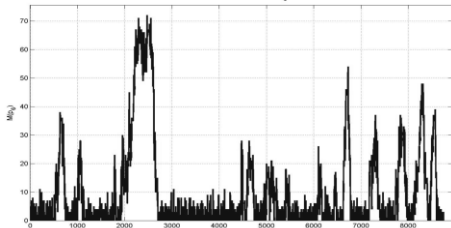
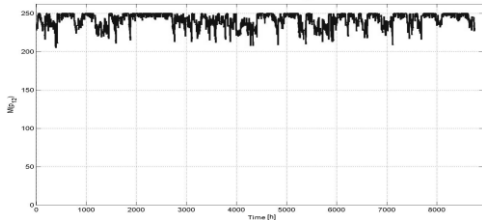
TABLE VI
PERFORMANCE INDICES OF TPN IN FIG. 15 - THROUGHPUT.

Scenarios	$Tr(T_{30})$ [veh/h]	$Tr(T_{31})$ [veh/h]	$Tr(T_{32})$ [veh/h]	$Tr(T_{50})$ [ITU/h]	$Tr(T_{55})$ [ITU/h]
As-is	2.73	0.78	2.06	1.46	2.56
1	3.07	0.80	2.43	1.75	3.02
2	3.30	0.82	2.63	1.89	3.27
3	3.72	0.81	3.10	0	0
4	3.63	0.82	3.05	0.38	0.48
5	3.62	0.82	3.05	2.16	3.72
6	3.69	0.81	3.08	2.18	3.77
7	4.61	0.79	4.00	2.90	5.12
8	2.71	0.80	2.03	0.16	0.15

TABLE VII
VALIDATION INDICES.

Performance Index	Meaning	PI	ρ	RPI
$Tr(T_6)$	Throughput of unloaded ITUs	2.94	0.04	2.98
$Tr(T_9)$	Throughput of exiting ITUs (to port)	0.88	0.03	0.88
$Tr(T_{12})$	Throughput of exiting ITUs (to customer)	2.17	0.04	2.18

Finally, we remark an average computation time of 1 minute is obtained for each replication on a PC with an Intel Core 2 Duo-2.80 GHz processor and 4 Gb RAM. The performance indices are obtained from 1000 independent replications with a 95% confidence. The half width of the confidence interval is about 0.9% in the worst case.

3) The model validation

Validation shows how closely the model represents the real system and it may be achieved by applying the single mean test [36]. Specifically, real data are provided by the company and compared with some representative performance index of the model. The half width of the relative confidence interval is determined. Table VII reports the performance indices obtained by the simulation with the relative half width of the confidence interval and the equivalent values computed by historical data provided by the company. Denoting by PI the generic performance index provided by the simulation, by RPI the corresponding index obtained by real data and ρ the relative half width of the confidence interval, Table VII shows that for each considered performance index it holds:

$$PI - \rho \leq RPI \leq PI + \rho \quad (11)$$

Hence, applying the single mean test [36], the results prove that the simulation closely represents the actual system.

Summing up, both case studies show that using the proposed model for IFTT analysis has a huge potential for verifying its efficient operation, allowing to synthetically measure the effective impact of new infrastructures, the criticality of failures or of increased traffic flows, etc.

VI. CONCLUSIONS

We propose a general, modular and systematic modelling framework for Intermodal Freight Transport Terminals (IFTTs), the key elements of an intermodal transport chain, to be used by decision makers in IFTT performance evaluation and optimization at an operational level. The presented model is based on the timed Petri nets formalism, which allows modeling IFTTs as discrete event systems, capturing the precedence relations and interactions among asynchronous events typical of these systems. Using a modular bottom-up approach, we identify the subsystems constituting a generic intermodal terminal. All subsystems are modeled by TPN modules and can be interconnected into a complete model by means of a systematic technique, allowing representing the whole IFTT and investigating the overall system dynamics. In the resulting model, places represent resources and capacities or conditions, transitions model inputs, flows and activities into the terminal, and tokens are intermodal transport units or the means on which they are transported. The model effectiveness is shown by means of two case studies - one from the literature and a real case study - evaluating the terminal efficiency in terms of performance indices and bottlenecks identification in a short computational time. Hence, simulating in a computer-based environment the proposed model turns out to be a decision support tool to assess the overall terminal management strategy, e.g., to assess the feasibility of alternative options when a new

potential market is considered.

Future research will consider the use of high level Petri nets formalisms to increase the modelling power of the approach. In particular, the use of coloured Petri nets may be investigated to model different unit loads moving in the system and hybrid Petri nets may be considered to represent not only discrete IFTT system dynamics but also continuous ones (e.g., related to high density traffic access roads). Moreover, we plan to investigate the complex subject of the structural analysis of the complete IFTT based on the proposed TPN modular model and on some concepts recently presented in the related literature: basis and macro markings.

REFERENCES

- [1] A. Alessandri, C. Cervellera, M. Cuneo, M. Gaggero, G. Soncin, "Modeling and feedback control for resource allocation and performance analysis in container terminals", *IEEE Trans. Intell. Transp. Sys.*, vol. 9, no.4, pp. 601-614, 2008.
- [2] A. Alessandri, C. Cervellera, M. Cuneo, M. Gaggero, G. Soncin, "Management of logistics operations in intermodal terminals by using dynamic modelling and nonlinear programming", *Marit. Econ. & Logist.*, vol. 11, no. 1, pp. 58-76, 2009.
- [3] K. Alicke, "Modeling and optimization of the intermodal terminal Mega Hub", *OR Spectrum*, vol. 24, pp. 1-17, 2002.
- [4] A. Baldassarra, S. Impastato, S. Ricci, "Intermodal terminal simulation for operations management", *Eur. Transp.*, vol. 46, pp. 86-99, 2010.
- [5] M. Bielli, A. Boulmakoul, M. Rida, "Object oriented model for container terminal distributed simulation", *Eur. J. Oper. Res.*, vol. 175, no. 3, pp. 1731-1751, 2006.
- [6] Y. M. Bontekoning, C. Macharis, J. J. Trip, "Is a new applied transportation research field emerging? A review of intermodal rail-truck freight transport literature", *Transp. Res.*, vol. 38, pp. 1-34, 2004.
- [7] V. Boschian, M. Dotoli, M. P. Fanti, G. Iacobellis, W. Ukovich, "A metamodeling approach to the management of intermodal transportation networks", *IEEE Trans. Autom. Sci. Eng.*, vol. 8, no. 3, pp. 457-469, 2011.
- [8] C. Caballini, C. Pasquale, S. Saccone, S. Siri, "An event-triggered receding-horizon scheme for planning rail operations in maritime terminals", *IEEE Trans. Intell. Transp. Syst.*, vol. 15, no. 1, pp. 365-375, 2014.
- [9] P. Canonaco, P. Legato, R. M. Mazza, R. Musmanno, "A queuing network model for the management of berth crane operations", *Comput. Oper. Res.*, vol. 35, no. 8, pp. 2432-2446, 2008.
- [10] A. Caris, C. Macharis, G. K. Janssens, "Planning problems in intermodal freight transport: accomplishments and prospects", *Transport. Plan. Techn.*, vol. 31, n. 3, pp. 277-302, 2008.
- [11] A. Caris, G. K. Janssens, C. Macharis, "Modelling complex intermodal freight flows", in *System Complexity to Emergent Properties, Understanding Complex Systems*. M. A. Aziz-Alaoui, C. Bertelle, Ed. Springer, Berlin, Heidelberg, pp.291-300, 2009.
- [12] A. Caris, C. Macharis, G. K. Janssens, "Decision support in intermodal transport: a new research agenda", *Comput. Ind.*, vol. 64, no. 2, pp. 105-112, 2013.
- [13] A. Cartenì, S. de Luca, "Tactical and strategic planning for a container terminal: modelling issues within a discrete event simulation approach", *Simul. Modelling Pract. Theory*, vol. 21, no. 1, pp. 123-145, 2012.
- [14] H. Chen, L. Amodeo, C. Feng, K. Labadi, "Modeling and performance evaluation of supply chains using batch deterministic and stochastic Petri nets", *IEEE Trans. Autom. Sci. Eng.*, vol. 2, no. 2, pp.132-144, 2005.
- [15] R. David, H. Alla. *Discrete, continuous, and hybrid Petri Nets*. Berlin Heidelberg, Springer-Verlag, 2005.
- [16] C. Degano, A. Di Febbraro, "On using Petri net to detect faulty behaviours in an intermodal container terminal", *Proc. 9th Meeting of the Euro Working Group on Transportation, "Intermodality, Sustainability and Intelligent Transportation Systems"*, Bari, Italy, 2002.
- [17] W. DeWitt, J. Clinger. *Intermodal Freight Transportation. Transportation Research Board - Transportation in the New Millennium: State of the Art*, 2000.
- [18] A. Di Febbraro, G. Porta, N. Sacco, "A Petri net modelling approach of intermodal terminals based on Metrocargo system", *Proc. 9th Intelligent Transportation Systems Conf.*, Toronto (Canada), pp. 1442-1447, 2006.
- [19] M. Dotoli, N. Epicoco, M. Falagario, G. Cavone, "A timed Petri nets model for intermodal freight transport terminals", *Proc. 12th Int. Works. Discr. Ev. Sys. WODES2014*, Paris-Cachan, France, pp. 176-181, 2014.
- [20] M. Dotoli, N. Epicoco, M. Falagario, G. Cavone, B. Turchiano, "Simulation and performance evaluation of an intermodal terminal using Petri nets", *Proc. Int. Conf. Contr., Dec. Inform. Techn. CoDIT2014*, Metz, France, pp. 327-332, 2014.
- [21] M. Dotoli, M. P. Fanti, "A coloured Petri net model for automated storage and retrieval systems serviced by rail-guided vehicles: a control perspective", *Int. J. Comp. Integ. Manuf.*, vol.18, no. 2-3, pp. 122-136, 2005.
- [22] M. Dotoli, M. P. Fanti, G. Iacobellis, A. M. Mangini, "A first order hybrid Petri net model for supply chain management", *IEEE Trans. Autom. Sci. Eng.*, vol. 6, no. 4, pp. 744-758, 2009.
- [23] M. Dotoli, M. P. Fanti, A. M. Mangini, G. Stecco, W. Ukovich, "The impact of ICT on intermodal transportation systems: a modelling approach by Petri nets", *Contr. Eng. Pract.*, vol. 18, no. 8, pp. 893-903, 2010.
- [24] M. Dotoli, S. Hammadi, K. Jeribi, C. Russo, H. Zgaya, "A Multi-Agent Decision Support System for Optimization of Co-Modal Transportation Route Planning Services", *Proc. 52nd IEEE Conf. Decision and Control*, Florence, Italy, 2013.
- [25] M. Dotoli, N. Epicoco, M. Falagario, D. Palma, B. Turchiano, "A train load planning optimization model for intermodal freight transport terminals: a case study", *Proc. IEEE Conf. Systems, Man and Cybernetics*, Manchester, United Kingdom, 2013.
- [26] M. Dotoli, N. Epicoco, M. Falagario, C. Seatzu, B. Turchiano, "An optimization technique for intermodal rail-road freight transport terminals", *Proc. IEEE Int. Conf. Robot. Autom.*, Hong Kong, China, 6 pp, 2014.
- [27] Y. Du, W. Tan, M. Zhou, "Timed compatibility analysis of web service composition: a modular approach based on Petri nets", *IEEE Trans. Autom. Sci. Eng.*, vol. 11, n. 2, pp. 594-606, 2014.
- [28] EU, "White paper on transport – Roadmap to a single European transport area", 2011.
- [29] K. Filipova, T. Stojadinova, V. Hadjitanasova, "Application of Petri Nets for transport streams modeling" *Facta Universitatis: Architecture and Civil Engineering*, vol. 2, no. 4, pp. 295-306, 2002.
- [30] L. M. Gambardella, M. Mastrolioli, A. E. Rizzoli, M. Zaffalon, "An optimization methodology for intermodal terminal management", *J. Intelligent Manufacturing*, vol.12, n. 5-6, pp.521-534, 2001.
- [31] A. Giua, F. DiCesare, M. Silva, "Generalized Mutual Exclusion Constraints on nets with uncontrollable transitions", *Proc. Int. Conf. Sys. Man Cybern.*, Chicago (U.S.), pp. 974-979, 1992.
- [32] A. Giua, C. Seatzu, "Modeling and supervisory control of railway networks using Petri nets", *IEEE Trans. Autom. Sci. Eng.*, vol. 5, no. 3, pp.431-445, 2008.
- [33] H. O. Günther, K. H. Kim, "Container terminals and terminal operations", *OR Spectrum*, vol. 28, pp. 437-445, 2006.
- [34] I. Harris, Y.L. Wang, H.Y. Wang, "ICT in multimodal transport and technological trends: unleashing potential for the future", *Int. J. Prod. Econ.*, vol. 159, pp. 88-103, 2015.
- [35] W.-S. Kim, J. H. Kim, H. Kim, H. Kwon, J. R. Morrison, "Capacity and queueing evaluation of port systems with offshore container unloading", *Proc. Int. Conf. Logist. Marit. Sys.*, Busan, South Korea, 2010.
- [36] A. L. Law, *Simulation modeling & analysis*, New York: McGraw, 2007.
- [37] C. Lee, H. C. Huang, B. Liu, Z. Xu, "Development of timed Colour Petri net simulation models for air cargo terminal operations". *Computers and Industrial Engineering*, vol. 51, no. 1, pp.102-110, 2006.
- [38] C. I. Liu, P. A. Ioannou, "Petri Net modeling and analysis of automated container terminal using Automated Guided Vehicle systems", *Transp. Res. Rec.*, vol. 1782, pp. 73-83, 2002.
- [39] C.I. Liu, H. Jula, P. A. Ioannou. (2002, March). Design, simulation, and evaluation of automated container terminals. *IEEE Trans. Intell. Transp. Syst.*, vol. 3, no. 1, pp. 12-26.
- [40] G. Maione, M. Ottomanelli, "A Petri net model for simulation of container terminal operations", *Advanced OR and AI Methods in Transportation*. (A. Jaszkiwicz et al. Eds.). Ed. House of Poznan University of Technology, Poznan, Poland. pp. 373-378, 2005.
- [41] K. G. Murty, J. Liu, Y. W. Wan, R. Linn, "A decision support system for operations in a container terminal", *Decis. Supp. Syst.*, vol. 39, no.3, pp. 309-332, 2005.

- [42] F. Parola, A. Sciomachen, "Intermodal container flows in a port system network: analysis of possible growths via simulation models", *Int. J. Prod. Econ.*, vol. 97, no. 1, pp. 75-88, 2005.
- [43] A. Perego, S. Perotti, R. Mangiaracina, "ICT for logistics and freight transportation: a literature review and research agenda", *Int. J. Phys. Distrib. Logist. Manag.*, vol. 4, no. 5, pp. 457-483, 2011.
- [44] J. L. Peterson. *Petri net theory and the modeling of systems*. Englewood Cliffs, Ed. Pearson, NJ: Prentice Hall, 1981.
- [45] A. E. Rizzoli, N. Fornara, L. M. Gambardella, "A simulation tool for combined rail/road transport in intermodal terminals", *Math. Comput. Simulat.*, vol. 59, no. 1-3, pp. 57-71, 2002.
- [46] F. Sessegò, A. Giua, C. Seatzu, "HYPENS: a Matlab tool for timed discrete, continuous and hybrid Petri nets", *Lecture Notes in Computer Science, Springer-Verlag*, vol. 5062, pp. 419-428, 2008.
- [47] C. A. Silva, C. Guedes Soares, J. P. Signoret, "Intermodal terminal cargo handling simulation using Petri nets with predicates", *J. Eng. Marit. Env.*, 2014.
- [48] R. Stahlbock, S. Voss, "Operations research at container terminals: a literature update", *OR Spectrum*, vol. 30, pp. 1-52, 2008.
- [49] D. Steenken, S. Voß, R. Stahlbock, "Container terminal operation and operations research - A classification and literature review", *OR Spectrum*, vol. 26, pp. 3-49, 2004.
- [50] United Nations, "Terminology on combined transport", New York and Geneva, 2001.
- [51] I. F. A. Vis, R. D. de Koster, "Transshipment of containers at a container terminal: an overview", *Eur. J. Oper. Res.*, vol. 147, no. 1, pp. 1-16, 2003.
- [52] N. Viswanadham. *Analysis of manufacturing enterprises: an approach to leveraging value delivery processes for competitive advantage*. Kluwer Academic, Boston, 1999.
- [53] A. Zimmermann, *Stochastic Discrete Event Systems: Modeling, Evaluation, Applications*, Springer, 2008.



Mariagrazia Dotoli (M'96, SM'12) received the Laurea degree in electronic engineering with honours in 1995 and the Ph.D. in electrical engineering in 1999 from Politecnico di Bari (Italy).

She has been a visiting scholar at the Paris 6 University and at the Technical University of Denmark. She is an expert evaluator of the European Commission

since the 6th Framework Programme. In 1999 she joined the Department of Electrical and Electronic Engineering of Politecnico di Bari as Assistant Professor in Control Systems Engineering. She has been the Vice Rector for research of Politecnico di Bari for 4 years until 2013 and she is currently a member elect of the Academic Senate of the same University. Her research interests include modeling, identification, management, control and diagnosis of discrete event systems, Petri nets, manufacturing systems, logistics systems, traffic networks.

Dr. Dotoli was co-chairman of the Training and Education Committee of ERUDIT, the European Commission network of excellence for fuzzy logic and uncertainty modeling in information technology, and was key node representative of EUNITE, the European Network of excellence on Intelligent Technologies. She is Associate Editor of the IEEE TRANS. OF AUTOMATION SCIENCE AND ENGINEERING and a member of the editorial board of the journals: MEDITERRANEAN J. OF MEASUREMENT AND CONTROL, INT. J. OF AUTOMATION AND CONTROL, INT. J. OF SYSTEMS SIGNAL CONTROL AND ENGINEERING APPLICATION, and INT. J. OF DISCRETE EVENT CONTROL SYSTEMS. She is the Workshop and Tutorial chair of the 2015 IEEE Conference on Automation Science and Engineering. She was the Special Session co-chair of the 2013

IEEE Conference on Emerging Technology and Factory Automation and chair of the National Committee of the 2009 IFAC Workshop on Dependable Control of Discrete Systems. She has been member of the International Program Committee of 50+ international Conferences and Symposia. She is a member of the following committees: IFAC Technical Committee on Discrete Event and Hybrid Systems (since 2011); IEEE Systems Man and Cybernetics Society Technical Committee on Discrete Event Systems (since 2007); IEEE Control Systems Society Technical Committee on Discrete Event Systems (since 2005). She is author or co-author of 150+ printed publications, including 1 book (in Italian) and 35+ papers on international journals. Her h-index equals 16.

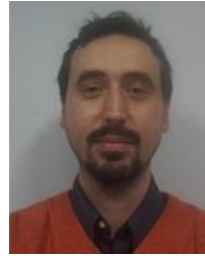

Nicola Epicoco was born in Bari, Italy, in 1976. He received the Laurea degree in Mechanical Engineering at Politecnico di Bari (Italy) in 2002. He is currently carrying on his Ph.D. in Electrical and Information Engineering at Politecnico di Bari, focusing on the impact of ICT tools on intermodal transport systems.

His research interests include modeling, simulation, optimization, management and control of discrete event systems, Petri nets, supply chains and urban traffic networks, manufacturing systems, distribution and internal logistics, transportation systems.



Marco Falagario was born in Bari, Italy, in 1976. He received the Laurea degree in Mechanical Engineering at Politecnico di Bari (Italy) in 2001, where he received his Ph.D. in Economics and Business Engineering in 2005.

He is consultant for companies both in the private and public sector.

His research interests include modeling, optimization, management and control of discrete event systems, supply chains and urban traffic networks, manufacturing systems, distribution and internal logistics, transportation systems.



Graziana Cavone was born in Bari, Italy, in 1985. She received the Laurea degree in Automation Engineering at Politecnico di Bari (Italy) in 2013.

She has been Research Fellow in Electrical and Information Engineering at Politecnico di Bari and is currently carrying on her Ph.D. in Electronics and Information Engineering at University of Cagliari (Italy), focusing on the use of ICT for the sustainable management of intermodal transport systems in smart cities.

Her research interests include modeling, simulation, optimization, management, diagnosis/prognosis and control of discrete event systems, Petri nets, manufacturing systems, transportation systems, and smart cities.