



Politecnico
di Bari

Repository Istituzionale dei Prodotti della Ricerca del Politecnico di Bari

Validation of Nuclear Magnetic Resonance Experiments Used in Food Certification

This is a PhD Thesis

Original Citation:

Validation of Nuclear Magnetic Resonance Experiments Used in Food Certification / Milella, Alessandra. - (2017).
[10.60576/poliba/iris/milella-alessandra_phd2017]

Availability:

This version is available at <http://hdl.handle.net/11589/99230> since: 2017-04-19

Published version

DOI:10.60576/poliba/iris/milella-alessandra_phd2017

Publisher: Politecnico di Bari

Terms of use:

(Article begins on next page)

			<p>Abstract</p> <p>Despite the advantages deriving from the use of NMR and despite the plethora of well documented validation processes, very few official NMR based quantification methods are known. With the aim to extend the use of NMR in official methods, NMR inter-laboratory comparison (ILC) for fingerprinting of on wheat and flour, was organized according to ISO/IEC 17043:2010 and reference normative therein. ILC provide objective standards for individual laboratories, permit them to compare analytical results from different laboratories and represent a way to check the quality and the accuracy of the analytical job. Validation by ILCs is the starting point for official recognition of the analytical methods. The aim of this inter-laboratory comparison was the validation of a fingerprinting NMR method for classification of wheat and flours. 39 NMR data sets were produced by 37 participants, from all over the world, using 46 spectrometer. In order to make a NMR method officially recognized, NMR data should be statistically processed according to European reference normative. The performance of each laboratory was assessed by means of a z-score which is related to the standard deviation. Laboratories endowed with z-score falling within the suitable acceptability range are able to guarantee a satisfactory performance. Results indicate that the NMR experiment (1D ¹H NQESY) proposed for the fingerprinting of wheat and flour aqueous extracts is a robust experiment. In fact, the majority of the participants produced NMR spectra that can be considered "statistically equivalent". The ulterior step in this direction was the validation of spectra processing procedures. All spectra obtained from this ILC were processed with Mnova Software with 2 different ways of calculation and with Top Spin once again.</p>					<p>D.R.R.S</p> <p>PhD in Risk and Environmental, Territorial and Building Development</p> <p>Coordinator: Prof. Michele Mossa</p> <p>XXIX CYCLE</p> <p>Curriculum: Food Chemistry</p> <p>DICATECh</p> <p>Department of Civil, Environmental, Building Engineering and Chemistry</p>	<p>POLITECNICO DI BARI</p> <p>09</p> <p>2017</p>
	D.R.R.S	D.R.R.S	Alessandra Milella	Alessandra Milella	Validation of nuclear magnetic resonance experiments used in food certification	Prof. Vito Gallo Prof. Mario Latronico DICATECh department Technical University of Bari	Validation of nuclear magnetic resonance experiments used in food certification		09



POLITECNICO DI BARI

D.R.R.S

PhD in Risk and Environmental, Territorial
and Building Development

09

2017

Coordinator: Prof. Michele Mossa

XXX CYCLE

Curriculum: Food Chemistry

DICATECh

Department of Civil, Environmental, Building
Engineering and Chemistry

**Validation of nuclear magnetic resonance
experiments used in food certification**

Prof. Vito Gallo
DICATECh department
Technical University of Bari

Prof. Mario Latronico
DICATECh department
Technical University of Bari

Alessandra Millella

 <p>POLITECNICO DI BARI</p>	<p>09</p>
<p>D.R.R.S Dottorato di Ricerca in Rischio, Sviluppo Ambientale, Territoriale ed Edilizio</p>	<p>2017</p>
<p>Coordinatore: Prof. Michele Mossa</p>	
<p>XXXIX CICLO Curriculum: Chimica degli Alimenti</p>	
<p>DICATECh Dipartimento di Ingegneria Civile, Ambientale, del Territorio, Edile e di Chimica</p>	
	<p>Validazione degli esperimenti di risonanza magnetica nucleare utilizzati nella certificazione alimentare</p>
	<p>Prof. Vito Gallo Dipartimento DICATECh Politecnico di Bari</p>
	<p>Prof. Mario Latronico Dipartimento DICATECh Politecnico di Bari</p>
	<p>Alessandra Milella</p>

EXTENDED ABSTRACT (eng)

Despite the advantages deriving from the use of NMR and despite the plethora of well documented validation processes (e.g., precision, accuracy, linearity, reproducibility, robustness, selectivity, and specificity), very few official NMR based quantification methods are known. With the aim to extend the use of NMR in official methods, NMR inter-laboratory comparison (ILC) for fingerprinting of wheat and flour, was organized according to ISO/IEC 17043:2010 and reference normative therein. ILC provide objective standards for individual laboratories, permit them to compare analytical results from different laboratories and represent a way to check the quality and the accuracy of the analytical job. Validation by ILCs is the starting point for official recognition of the analytical methods. The aim of this inter-laboratory comparison was the validation of a fingerprinting NMR method for classification of wheat and flours. 39 NMR data sets were produced by 37 participants, from all over the world, using 46 spectrometers. In order to make a NMR method officially recognized, NMR data should be statistically processed according to European reference normative. The performance of each laboratory was assessed by means of a z-score which is related to the standard deviation. Laboratories endowed with z-score falling within the suitable acceptability range are able to guarantee a satisfactory performance. Results indicate that the NMR experiment (1D ^1H NOESY) proposed for the fingerprinting of wheat and flour aqueous extracts is a robust experiment. In fact, the majority of the participants produced NMR spectra that can be considered "statistically equivalent". Thus, the main goal of this inter-laboratory comparison, the validation of the 1D ^1H NOESY experiment, was achieved along with the indication of the participants able to produce NMR spectra with the highest possible performances. Since no previous report is available for a comparative evaluation of the results, at this stage it is advisable to highlight some possible critical points taking into account the CV% values collected in this ILC. The ulterior step in this direction was the validation of spectra processing procedures. All spectra obtained from this ILC were processed with Mnova Software with 2 different ways of calculation and with Top Spin once again.

Keywords: Interlaboratory comparisons, Nuclear magnetic resonance, food fingerprinting

EXTENDED ABSTRACT (ita)

Nonostante i vantaggi derivanti dall'utilizzo della risonanza magnetica nucleare e nonostante la pleora di processi di validazione ben documentati (precisione, accuratezza, linearità, riproducibilità, robustezza, selettività e specificità), pochissimi metodi ufficiali basati su questa tecnica sono noti. Con l'obiettivo di estendere l'uso dell' NMR nei metodi ufficiali, è stato organizzato il primo confronto interlaboratorio (ILC) internazionale per il fingerprinting del grano e della farina, secondo la normativa ISO/IEC 17043:2010 e altri riferimenti normativi in vigore. ILC fornisce standard oggettivi per laboratori individuali, permettere loro di confrontare i risultati analitici provenienti da diversi laboratori e rappresenta un modo per controllare la qualità e la precisione del lavoro analitico. La validazione mediante ILC è il punto di partenza per il riconoscimento ufficiale di metodi analitici. 39 NMR data set sono stati prodotti da 37 partecipanti, provenienti da tutto il mondo, con un totale di 46 spettrometri. Al fine di rendere il metodo NMR ufficialmente riconosciuto, i dati NMR devono essere elaborati statisticamente secondo le normative europee di riferimento. Le prestazioni di ogni laboratorio sono state valutate mediante z-score, parametro relativo alla deviazione standard. I laboratori con uno z-score all' interno del range di accettabilità sono in grado di garantire prestazioni soddisfacenti. I risultati indicano che l'esperimento NMR (^1H 1D NOESY) proposto in questo ILC è robusto. Infatti, la maggior parte degli spettri NMR prodotti nel confronto può essere considerata "statisticamente equivalente". Dal momento che nessun precedente rapporto è disponibile per una valutazione comparativa dei risultati, in questa fase è opportuno mettere in evidenza alcune possibili criticità, tenendo conto dei valori% CV raccolti in questo ILC. Il passo successivo in questa direzione è stata la validazione della procedura di elaborazione degli spettri. Tutti gli spettri ottenuti da questo ILC sono stati elaborati mediante software Mnova con 2 modi differenti di calcolo e con Top Spin, ancora una volta.

Keywords: Confronto interlaboratorio, risonanza magnetica nucleare, certificazione alimentare

INDEX

1.0	<i>Introduction</i>	7
2.1	<i>Chapter I</i>	11
2.1	<i>Introduction NMR</i>	12
2.1.1	<i>Nuclear Magnetic Resonance</i>	12
2.1.2	<i>Relaxation processes and NMR signal generation</i>	17
2.1.3	<i>Instrumentations</i>	22
2.1.4	<i>Multivariate Statistical Analysis</i>	23
2.1.4.1	<i>Principal Component Analysis</i>	24
2.2	<i>Chapter II</i>	26
2.2.	<i>ISO 17043:2010 and the first national ILC</i>	27
2.2.1	<i>General data and matrix</i>	29
2.2.2	<i>Samples preparation</i>	33
2.2.3	<i>Preparation of blank</i>	33
2.2.4	<i>Standards preparation</i>	33
2.2.5	<i>Preparation of solutions for calibration curves construction</i>	34
2.2.6	<i>Preparation of unknown concentration solution</i>	35
2.2.7	<i>Samples delivery</i>	36
2.2.8	<i>Calibration curve</i>	36
2.2.9	<i>Data set</i>	36
2.2.10	<i>Statistical elaboration and results</i>	37
2.2.11	<i>Final comments</i>	39
2.3	<i>Chapter III</i>	41
2.3	<i>Validation of tests and calculation</i>	42
2.3.1	<i>Validation of Cochran test</i>	44
2.3.2	<i>Validation of Huber test</i>	48

2.3.3	<i>Validation of average of averages</i>	50
2.3.4	<i>Validation of maximum value</i>	50
2.3.5	<i>Validation of minimum value</i>	50
2.3.6	<i>Validation of range</i>	50
2.3.7	<i>Validation of median</i>	51
2.3.8	<i>Validation of degrees of freedom</i>	51
2.3.9	<i>Validation of interlaboratory standard deviation</i>	52
2.3.10	<i>Validation of coefficient of variation</i>	52
2.3.11	<i>Validation of repeatability variance</i>	53
2.3.12	<i>Validation of variance interlaboratory</i>	53
2.3.13	<i>Validation of variance of reproducibility</i>	55
2.3.14	<i>Validation of lower confidence limit</i>	55
2.3.15	<i>Validation of upper confidence limit</i>	57
2.3.16	<i>Validation of confidence range</i>	58
2.3.17	<i>Validation of reproducibility limit</i>	59
2.4	<i>Chapter IV</i>	61
	<i>2.4. Wheat</i>	62
	<i>2.4.1. Plant structure</i>	62
	<i>2.4.2 Caryopsis structure and composition</i>	68
	<i>2.4.3 Production of wheat</i>	71
	<i>2.4.4 Wheat flour milling</i>	72
2.5	<i>Chapter V</i>	74
	<i>2.5. Durum wheat fingerprinting</i>	75
	<i>2.5.1 Materials and Methods</i>	75
	<i>2.5.2 Results and discussion</i>	78
2.6	<i>Chapter VI</i>	82
	<i>2.6 The first international ILC- Validation of a 1D 1H-NOESY experiment for fingerprinting of wheat</i>	

	<i>and flour</i>	83
	2.6.1. <i>The scheme of IS-NMR-ILC</i>	83
	2.6.2. <i>Privacy and general data on participants</i>	93
	2.6.3. <i>Statistical elaboration</i>	95
	2.6.4 <i>Performance assessment</i>	96
	2.6.5 <i>Homogeneity and stability test</i>	96
	2.6.6 <i>Temperature calibration</i>	98
	2.6.7 <i>Results</i>	100
	2.6.8 <i>Tube B</i>	101
	2.6.9 <i>Tube C</i>	115
	2.6.10 <i>Tube D</i>	129
	2.6.11 <i>Tube E</i>	143
	2.6.12 <i>Final comments</i>	157
2.7	<i>Chapter VII</i>	159
	2.7 <i>Validation of NMR fingerprinting methods: effects of processing on measure reproducibility and laboratory performance assessment</i>	160
	2.7.1 <i>Tube B</i>	163
	2.7.2 <i>Tube C</i>	177
	2.7.3 <i>Tube D</i>	191
	2.7.4 <i>Tube E</i>	205
	2.7.5 <i>Final comments</i>	219
3.0	<i>Conclusion</i>	224
4.0	<i>References</i>	226
5.0	<i>Acknowledgements</i>	232
6.0	<i>Curriculum</i>	234

INTRODUCTION

1.0 Introduction

One of the most significant part of national economy is represented by agri-food field. The integration between agriculture, industry and distribution is becoming increasingly intense and the need to define quality and security's aims, that could be shared by different segments of production chain, is consequently necessary, as also the intention of providing safe products, with defined characteristics, recognizable by consumers and difficult to replace with substitute products. In these latest years, there was a considerable demand of food products diversification. It caused, on one hand the request of typical and traditional foods, dedicated to a rediscovery of ancient flavors, and on the other hand the request of foods that are characterized by freshness, authenticity and prepared in full respect of quality and safety standards. Thus, new qualification strategies and tools to promote food products have been developed in order to satisfy consumer that is become even more careful and exigent as far as concern quality, healthy, and safety (Andreini,1995). Food traceability was born as an inner necessity of companies, but now has become a real legislative obligation and a strategic mean for agri-food businesses. It increases the value of agri-food products, giving consumers more information about supply chain, such as: origin, agronomic techniques, production and transformation methods. Each step of the chain is called "track". Traceability, following food's tracks, allows us to rebuild productive path. Traceability, is one of the most important tools for quality and food safety, that allows to trace and follow a food and to inform consumers how the product is made. In case of hazard, it allows to immediately block the source of damage, and retire products from market too. In fact, since 2002 regulation CE number 178, that defines traceability, represents a valuable tool to safeguard cultures, traditions, and typical productions (Pacchili and Bussi 2003).

In this framework, my PhD project consists in the development of innovative analytical tools for food products' enhancement. In order to certify origin, quality and typicality of different food matrices, it is possible identify, quantitatively and qualitatively, all metabolites by metabolomic approach. European institutional organizations are committed, as far as concerned certifications, for the protection of consumers and food producers. However, analytical methods based on the knowledge of food molecular composition are not yet recognized as tools for food certifications. Thus the main goal of this research is the de-

velopment of an unconventional system of traceability based on the definition of the metabolic profile of foods, through the elaboration of spectra obtained by nuclear magnetic resonance analytical technique. Currently, control of quality and origin of food products requires analytic techniques that, although guaranteeing results with high sensitivity and precision, resulting in time consuming experiments mainly due to pre-treatment of samples. Moreover, these analytical techniques are often selective for a particular metabolite or chemical class of product. Consequently, the application of these methods envisages that is known in advance the composition of the matrix and chemical and physical characteristics of each analytes, in order to be able to choose the right analytical technique. This gives an idea of the complexity of the problem, especially in case of characterization of many substances that constitute metabolic profile. In the last two decades, innovative methods have been developed allowing determination of the metabolic profile. Nuclear Magnetic Resonance (NMR) can be applied to a wide range of matrices. NMR technology was initially used in the late 1940s to elucidate the structure of molecules in organic chemistry (Gutowsky et al, 1949). With the development of NMR instrumentation and improved programs to collect and analyze the data, NMR applicability has recently and rapidly expanded in the field of food science and technology. A wide range of NMR food-related research has covered various fields of food science, including food chemistry, food engineering, food microbiology, and food packaging (Marcone et al., 2013). Innovations of this analytical technique consist in a different point of view regarding chemical analysis. NMR technique is based on a simultaneous characterization of components that make each product unique. Since its first application as quantitative technique (Jungnickel and Forbes, 1963), NMR spectroscopy has been successfully used for many applications involving several kind of matrixes (small molecules, pharmaceuticals and natural products in both simple and complex mixtures). One of the major advantages of quantitative NMR (qNMR) is its primary analytical characteristic. It can be applied in the estimation of purity of compounds without using any specific reference standard. Moreover, recent progress in the development of high sensitive instruments allowed for reduction of the detection limits, thus making the technique appealing for analysis of molecules in very low concentrations. Despite the advantages deriving from the use of qNMR and despite the plethora of well documented validation processes (e.g., precision, accuracy, linearity, reproducibil-

ity, robustness, selectivity, and specificity), very few official NMR based quantification methods are known.

With the aim to extend the use of qNMR in official methods, NMR interlaboratory comparisons (ILCs) are organized according to ISO/IEC 17043:2010 and reference normative therein. ILCs provide objective standards for individual laboratories, permit them to compare analytical results from different laboratories and represent a way to check the quality and the accuracy of the analytical job (Ward et al, 2010). Validation by ILCs is the starting point for official recognition of the analytical methods. Normally, NMR spectra are collected in a database with the aim to create fingerprint of the food of interest. In order to make a NMR method officially recognized, NMR data should be statistically processed according to either UNICHIM 179/2011, UNI ISO 5725-2 or new statistical criteria to be drawn.

Thus, my PhD thesis project aims to validate innovative analytical solutions based on the use of NMR spectroscopy for food valorization. Thus, new NMR methods and validation systems will be to identify and classify food productions in terms of genetic and geographical origin, agronomic practices and technologies used during production. This approach allows to estimate food's metabolites and to understand how genetic, technological and environmental factors could modify food products. These methods are intended to support product certification marks (for instance, DOP, IGP, BIO, etc.) and hopefully to provide new tools for a better strategic position of the companies on international market.

The main points that was be considered are:

- minimization of variance in sample preparation and instrument performance, so to elucidate even subtle differences in metabolite fingerprints and;
- organization of interlaboratory comparisons for testing methods on a multiple instruments scale and to set up criteria for laboratory performance evaluation;
- validation of calculations of NMR data of ILCs.

CHAPTER I

2.1 Introduction NMR

During the last two decades, Nuclear Magnetic Resonance (NMR) spectroscopy has been widely applied to agro-food products. NMR analyses conducted on food products have the following characteristic:

- they are non-invasive and untargeted;
- they discriminate a large number of components, even in complex mixtures;
- they allow to obtain information on the chemical composition, the dynamics and the molecular structure of vegetable matrices and their extracts.

NMR spectroscopy gives detailed information on the molecular structure of each metabolite preserving possible additional information on the system. An advantage of NMR regards sample preparation which might not require any physical or chemical treatment before analysis (Colquhoun, I.L. and Lees, M. 1998). Given the large amount of metabolites contained in an agro-food matrix, the NMR spectrum is very rich, thus rendering a tricky task. [the process of complete identification of the compounds]. This does not represent a real problem, because NMR spectra can be used as a code to identify a particular product in a context of traceability, or used to group the samples according to specific compositional characteristics (this approach is commonly called "profiling"). Later all data collected are studied by means of multivariate statistical analysis based on mathematical and statistical procedures. Thus, the multivariate analysis becomes an excellent tool for exploring all data contained in the NMR spectra without a deep knowledge of the metabolites that compose the sample. Statistical comparisons and multivariate statistical identification techniques involve unsupervised clustering such as Principal Component Analysis (PCA) (Smith, 2002) or supervised classification such as Linear Discriminant Analysis (LDA) (Pirouz, 2006), Partial Least Squares (PLS) (Dixon et al., 2007) and Partial Least Squares Discriminant Analysis (PLS-DA) (Westerhuis et al., 2008).

2.1.1 Nuclear Magnetic Resonance

Nuclear Magnetic Resonance Spectroscopy is one of the most valuable tools to observe and understand phenomena of different nature, in the field of chemistry, physics, biology and medicine. It is a powerful analytical technique, which gives detailed infor-

mation concerning the molecular structure of the biological material observed, reflecting at the end the metabolic status of a biological living system, without losing important information on the system. The principle of NMR was predicted in the mid-1930s by Gorter (Gorter, 1936), but it was not applied until 1945, when two research groups Bloch, Hansen, Packard (Bloch, 1946) and Purcell, Torrey and Pound (Purcell 1946) observed first NMR signals in independent researches. Bloch and Purcell received the Nobel prize for this discovery in 1952.

NMR spectroscopy measures the absorption of electromagnetic radiation in molecules immersed in a strong magnetic field. In the classical description, the atomic nucleus is regarded as a sphere in rotation around an axis, so each nucleus possesses an intrinsic angular momentum P :

$$P = \sqrt{I(I + 1)} \frac{h}{2\pi}$$

(1)

where I is the spin angular momentum and h is the Plank constant.

The value of nuclear spin I depends on the atomic number and atomic mass:

- if the atomic mass is odd, I is half of a integer number and the nucleus is NMR active (^1H , ^{13}C , ^{15}N , ^{31}P);
- if the atomic number is odd and the atomic mass is even, I is an integer and the nucleus is NMR active (^{14}N , ^2H);
- if the atomic number and atomic mass are even, I is zero and the nucleus is NMR silent (^{12}C , ^{16}O).

Elements can have more than one isotope with non-zero nuclear spin, each one with its own natural abundance. In the following table, some common NMR nuclei are listed along with their natural abundance and I .

Table 1. Spin nuclear and abundance of different nucleus

Nucleus	Percentage abundance (%)	I
¹ H	99.98	1/2
¹¹ B	80.42	3/2
¹³ C	1.108	1/2
¹⁴ N	99.63	1
¹⁵ N	0.37	1/2
¹⁷ O	0.037	5/2
¹⁹ F	100	1/2
²³ Na	100	3/2
²⁷ Al	100	5/2
²⁹ Si	4.70	1/2
³¹ P	100	1/2

The nuclear magnetic moment is directly proportional to the angular momentum P:

$$\vec{\mu} = \gamma \vec{P} \quad (2)$$

Under normal conditions, the orientation of the magnetic moments is random. In the presence of an external field B_0 , conventionally oriented along the z axis, a particle with spin $\frac{1}{2}$ can assume two different orientations (Figure 1): one parallel to the field (α state, with a lower energy) and another one antiparallel to the field (β state, with a higher energy).

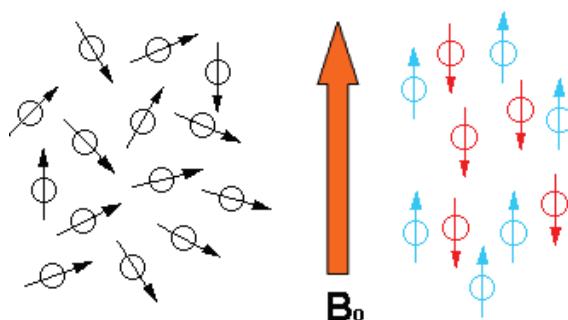

Figure 1.

The energy difference (ΔE) between the two states is directly proportional to B_0 according to:

$$\Delta E = \frac{\gamma h}{B_0} \quad (3)$$

with γ being the gyromagnetic ratio and $h/2\pi$ is the quantum of angular momentum. The dependence of ΔE by applied magnetic field strength is shown in figure 2 for nuclei with $I = 1/2$.

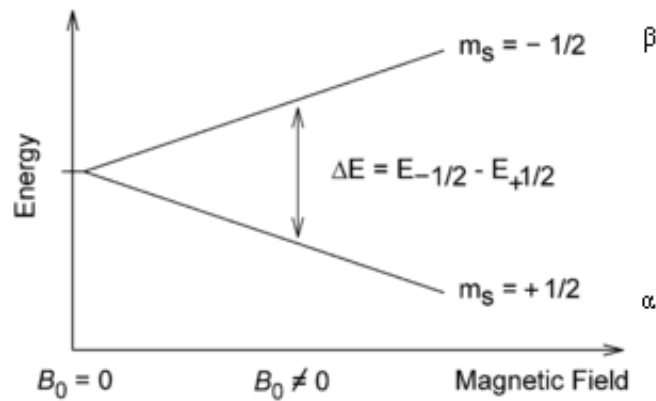

Figure 2. The splitting of the spin states of nucleus with $I = 1/2$ upon application of a magnetic field.

In order to promote a transition between the two spin states, a radiofrequency with $\nu_0 = (\gamma/2\pi)B_0$ is required. When such a frequency is equal to the precession frequency of the nuclei under the influence of B_0 , a resonance condition is achieved and the frequency is denoted as Larmor frequency ν_L

$$\nu_L = \frac{\gamma B_0}{2\pi} \quad (4)$$

In equilibrium, the α state is thermodynamically favored and therefore more populated compared to the state β . The population difference between two spin states is given by the Boltzmann distribution function:

$$\frac{N_{\beta}}{N_{\alpha}} = e^{\frac{-\Delta E}{kT}} \quad (5)$$

where N_{α} and N_{β} , represent the spin states populations, k is the Boltzmann constant and T the temperature. Since the energy difference between the two spin states is very small, the corresponding population differences are similarly small. Anyway, the slight excess of the nuclei in α state is responsible of the net magnetization that is fundamental in NMR spectroscopy. According to the classic representation, a nucleus with spin 1/2 moves around the z axis, coincident with the axis of the applied magnetic field on the surface of a double cone (Figure 3).

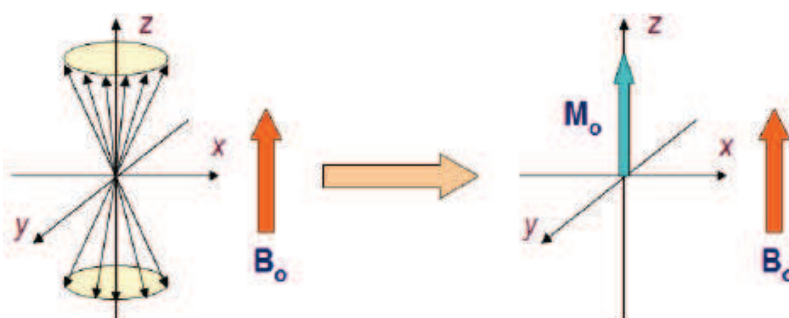

Figure 3. Representation of magnetization vector

The vector sum of all the magnetic moments of the nuclei contained in the sample gives the macroscopic magnetization M_0 . This vector has the direction coincident with that of the magnetic field B_0 . When an electromagnetic radiation, generated by a sinusoidal current flow, is given to the system, the system is perturbed. The electromagnetic radiation can be considered as an applied magnetic field B_1 ($|B_1| \ll |B_0|$), orthogonal to B_0 , because it originates from a coil wrapped in the plane xy (Sanders and Hunter, 1988; Silverstein and Webster, 2004). The interaction between the magnetization vector M_0 and the ap-

applied magnetic field B_1 occurs when the radiofrequency generating B_1 is equal to the Larmor frequency. In this way, the transition between the two energy levels α and β occurs through the absorption of the radiofrequency ν . For magnetic fields applied in common NMR spectrometers (from 1 to 20 Tesla), the frequency of precession of nuclei varies from tens to hundreds of MHz. Perturbation of equilibrium condition, necessary for experiment execution, consists of a short (few microseconds) and intense pulse of energy able to generate the desired radiofrequency. Such a pulse excites simultaneously all nuclei resonating within a continuous band of frequencies which are symmetrical with respect to the frequency centre ν_1 (Keeler, 2002). Pulse application has the effect of the abovementioned applied magnetic field B_1 . The interaction between B_1 and magnetization M_0 produces a torque that moves the magnetization vector in the xy plane with intensity M_{xy} . The pulse generating this shift from the z axis to the xy plane is named 90° pulse (Figure 4). After the perturbation, the system tends to restore the equilibrium condition where the energy levels are repopulated according to Boltzmann distribution. Such a process is denoted as relaxation of the nuclei. During relaxation, magnetization M_0 returns to its initial value aligned along the z axis, while magnetization M_{xy} loses progressively its intensity to reach a net value equal to 0.

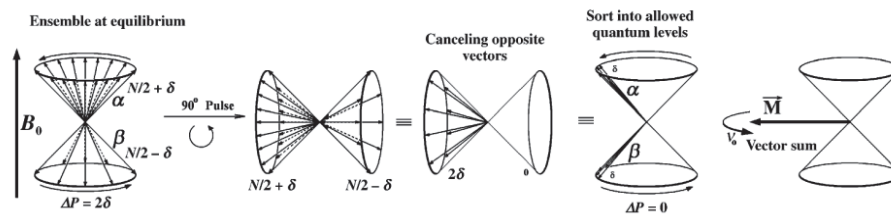

Figure 4. Representation of magnetization vector and a 90° pulse (Jacobsen, 2007).

2.1.2 Relaxation processes and NMR signal generation

Relaxation process allowing vector M_0 to return to its initial position along the z is due to two different relaxation sub-processes:

- Longitudinal or spin-lattice relaxation

- Transverse or spin-spin relaxation

The first sub-process considers the energy exchanges taking place between the spin system and the molecular environment and produces an increment of the magnetization along the z axis to equilibrium value M_0 (Figure 5). In this type of relaxation, in homogeneous systems, the magnetization recovery usually follows a trend fitted by the exponential and characterized by a constant T_1 denoted as longitudinal relaxation constant.

$$M_z = M_0 \left[1 - e^{\left(-\frac{t}{T_1}\right)} \right] \quad (6)$$

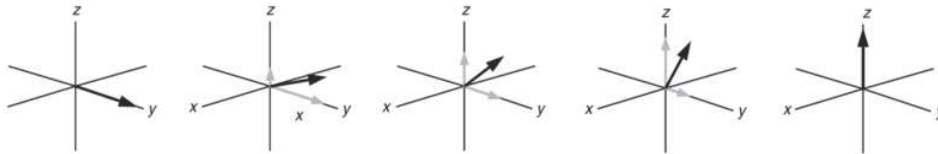

Figure 5. Longitudinal or spin-lattice relaxation (Claridge, 2009).

Transverse relaxation consists of the loss of phase coherence among the resonances of the nuclear spins (Figure 6) with the concomitant loss of magnetization intensity in the xy plane resulting in the cancellation of the magnetization in the same xy plane. Such a magnetization decay usually follows a trend fitted by the exponential and characterized by a constant T_2 denoted as transverse relaxation constant:

$$M_{xy} = M_0 \left[e^{\left(-t/T_2\right)} \right] \quad (7)$$

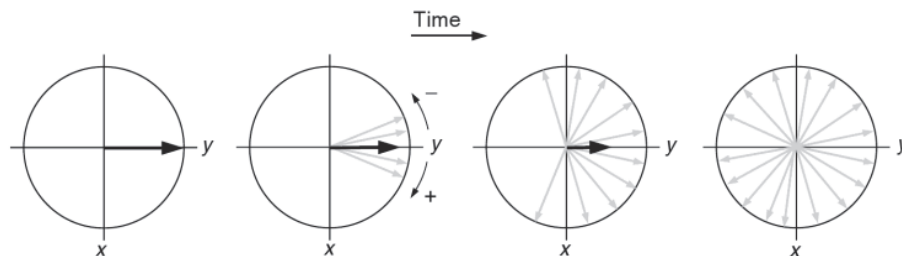

Figure 6. Transverse or spin-spin relaxation (Claridge, 2009).

The graphical representation of the M_{xy} decay in the rotating frame and in the laboratory frame is shown in figure 7.

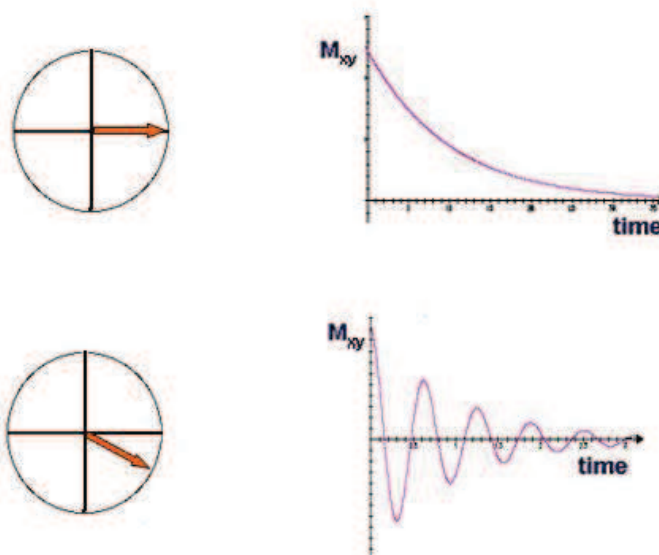

Figure 7.- Representation of the M_{xy} decay in the rotating frame (up) and in the laboratory frame (down)

The intensity of M_{xy} is recorded by a detector and analysed to extract chemical information. The detector consists of a receiver coil placed perpendicularly to the z axis. It receives a combination of frequencies forming output signal called FID (Free Induction Decay). This is a signal in the time domain that is converted into a signal in the frequency domain by Fourier transformation (FT) (Figure 8). Commonly, the Fourier transformation of a single FID generates a low intensity signal with a low signal to noise ratio. In order to

increase the intensity of the output signal, and then the signal to noise ratio (by a factor equal to \sqrt{n}), n measurements are executed. In this case, a delay (named recycling delay or relaxation delay) must separate the experiments with the aim to allow M_0 recovery before the successive application of the 90° pulse.

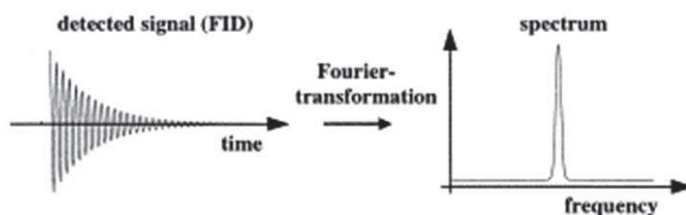

Figure 8. Fourier transformation

When NMR signals are used for quantitative methods, acquisition and processing parameters must be equal for all samples to be compared, as they may influence the finer details in the spectra. In real samples, nuclei are never isolated each other but are affected by local magnetic fields generated by the surrounding electrons. Such magnetic fields are less intense of the applied field, but cannot be ignored. The interaction between each nucleus and these small magnetic fields causes little variations in the energy levels and then little differences in the NMR signals. The magnetic field at the nucleus (the effective field B_{eff}) is generally lower than the applied one by a fraction σ denoted as nuclear magnetic shielding according to the following equation:

$$B_{eff} = B_0 (1 - \sigma) \quad (8)$$

As a consequence, the Larmor frequency ν_L , for a given nucleus must be rewritten as:

$$\nu = \frac{\gamma B_{eff}}{2\pi} = \frac{\gamma B_0}{2\pi} (1 - \sigma) \quad (9)$$

The dependence of ν from the applied magnetic field B_0 prevents a direct comparison between signals generated by different spectrometers. In order to render the resonating frequency independent on B_0 and indicative of specific nuclei, the chemical shift δ was intro-

duced as the difference between the resonance frequency of a given nucleus ν and that of a frequency ν_0 related to a standard compound:

$$\delta = (\nu - \nu_0) 10^6 / \nu_0 \quad (10)$$

For ^1H NMR spectroscopy, the most common standard compound is $\text{Si}(\text{CH}_3)_4$ (tetramethylsilane, TMS) which is soluble in many organic solvents, is inert and possesses twelve equivalent protons generating a single signal. Such a signal is conventionally fixed to 0.00 ppm. In solution, when the local field of a given nucleus is affected by a nearby nucleative (or set of nuclei), a split of the energy levels (and then of the signals) occurs depending on the number of the surrounding nuclei and their nuclear spin I . This phenomenon is called scalar spin-spin coupling and represents the indirect magnetic interaction of nuclear spins with each other through the involvement of the electrons. Scalar coupling manifests itself by signal splitting and is characterized by a coupling constant J accounting for the specific chemical features of the molecule. The chemical shift and the coupling constant are important parameters linking NMR spectroscopy and chemistry. In fact, the chemical shift indicates the local electronic environment and the J coupling provides a direct spectral manifestation of the chemical bonds (Jackman and Sternhell, 2013).

The most important parameters extractable from a NMR spectrum are:

- The chemical shift, which indicates the chemical group contained in the molecule;
- The multiplicity of the signal and the spin-spin coupling constant J related to the structure of the molecule;
- The intensity of the signal which is directly related to the number of nuclei in the sample.

In order to obtain a well-resolved NMR spectrum, the applied magnetic field B_0 must be long lasting stable in intensity and homogeneous within the sample. Concerning the field stability, even though spectrometers ensure very high performance, little field fluctuations are unavoidable and this results in signal broadening. Such a problem is efficiently overcome by a lock procedure on deuterium contained in a reference compound. That is the reason for the use of deuterated solvents in preparation of the NMR samples. The homo-

geneity of the magnetic field in close proximity of the sample is controlled and adjusted by shimming procedures consisting of application of very weak additional fields.

2.1.3 Instrumentations

A typical NMR spectrometer consists of a magnet, a radio frequency generator, a receiver unit and a probe. Commercial NMR spectrometers were introduced in 1953. These instruments had permanent magnets or electromagnets with applied fields at 1.41, 1.88, 2.12, 2.35 T corresponding to Larmor frequencies of proton at 60, 80, 90 and 100 MHz, respectively. Currently, magnets are based on superconducting materials cooled in liquid helium. Spectrometers work with pulsed techniques which are able to stimulate all the nuclei contained in the sample by a radio frequency pulse. The excited nuclei return to the lowest energy level and produces FID, the ensemble of signals recorded in the time domain by the receiver unit. FID is converted in frequency domain spectrum by Fourier transformation giving NMR signals easy to interpret. The following figure shows the functional scheme of a generic NMR spectrometer (Figure 9).

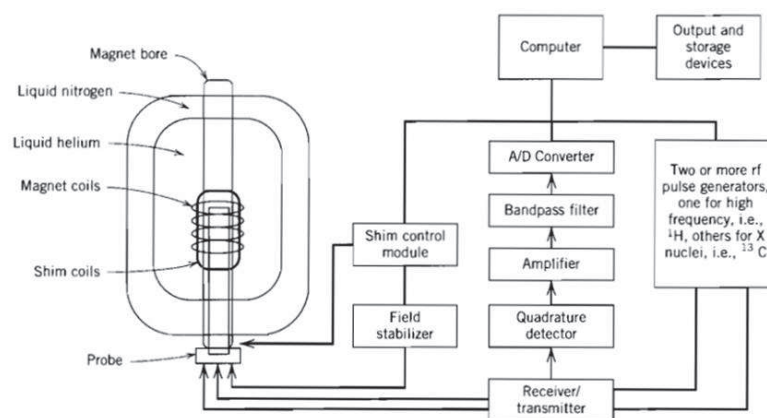

Figure 9. Scheme of a generic NMR spectrometer

A very important component of a NMR spectrometer is the probe which represents the interface between a sample and the instrument allowing for excitation and detection of the nuclear spins. The probe is located into the centre of the magnetic field and is equipped

with a temperature controller. It contains the radiofrequency (R_f) coils tuned at specific frequencies. Often, probes are constructed with two coils, the inner coil closest to the sample, and the outer coil more distant from the sample. The nuclei excited by the inner coil are detected with the highest sensitivity. When the inner-coil is tuneable in a wide range of frequencies (broadband coil) the probe is denoted as “broadband observe” probe and allows for excitation/detection of many nuclei having their Larmor frequencies in a well defined range (i.e. frequencies between ^{31}P and ^{15}N). When the inner-coil is tuned to ^1H Larmor frequency, the probe is denoted as “broadband inverse” or “indirect detection” probe and gives the highest proton sensitivity. Modern NMR probes also include an actively-shielded Pulsed Field Gradient (PFG) coil which allows for execution of powerful and rapid experiments by application of field-gradient pulses.

2.1.4 Multivariate Statistical Analysis

A system can be described by one or more variables and graphically represented in a space mono- to three-dimensional. When many variables are required for the appropriate description of the system under investigation, 1-3D graphical representation is not viable and a space of higher size must be considered. In order to solve problems deriving from the use of many variables, Multivariate Statistical Analysis (MSA) is applied to the set of available analytical data. MSA can be performed by unsupervised or supervised methods. The unsupervised methods seek discriminating factors between the independent variables with the aim to obtain a graphical representation as the result of maximization of variances. On the contrary, supervised methods find the best fitting relationship between independent and dependent variables after a first step called calibration. The goodness of this step is then evaluated on unknown samples during the subsequent test step. Application of MSA to real data obtained in analytical chemistry has taken the name of chemometrics. In particular, the multivariate data analysis techniques used during the thesis were Principal Component Analysis (PCA) as unsupervised method and Partial Least Squares Discriminant Analysis (PLS-DA) as supervised method.

2.1.4.1 Principal Component Analysis

The Principal Component Analysis is a technique for organizing and simplifying multivariate data. This technique analyzes a data table in which observations are described by several inter-correlated quantitative dependent variables. It reduces the volume of a data set generating new variables that preserve the same initial information. The new variables are latent (called principal components, PCs) and are uncorrelated (orthogonal) to each other. Its goal is to extract the important information from the table, to represent it as a set of new orthogonal variables, and to display the pattern of similarity of the observations and of the variables as points in maps. (Abdi and Williams, 2010). Graphical representation of such variables gives easily interpretable information inherent in the initial matrix.

Starting from a data matrix X of dimension $n \times p$, PCA generates a space in which axes are created in such a way that the first axis (PC_1) is oriented in the direction of maximum variance of the data, the second (PC_2) is perpendicular to the first one and is in the direction of the next maximum variance of the data, and so on for all p new axes. Each component is the linear combination of the original variables. The mathematical procedure for the determination of the principal components consists at the calculation of eigenvalues λ_m and eigenvectors λ_m of the covariance (or correlation) matrix S of the data. In other words, this procedure is the diagonalization of the covariance matrix S of X .

$$\text{diag}(S) = \text{diag} \frac{X^T X}{n-1}$$

(11)

This implies the determination of:

- A diagonal matrix of eigenvalues, $\Lambda(p,p)$ said eigenvalues matrix, whose diagonal elements are the eigenvalues λ_m sorted in descending order;
- A matrix of loadings $L(p,m)$, whose columns are the eigenvectors λ_m of the covariance matrix (the eigenvectors are the PCs of the new space).

The product between X and L gives a new matrix T of dimension $n \times m$ called scores matrix.

$$T(n \times m) = X(n \times p)L(p \times m) \quad (12)$$

The value of m , that is the number of eigenvectors λ_m , can be lower than or equal to p depending on the significance of the information associated to eigenvalues λ_m . Since eigenvalues λ_m represent the variance associated to each eigenvectors λ_m (principal component), it is possible that little variances, and then lower eigenvalues, are due to noise or unimportant information. In such cases, it is advisable to consider only the most important eigenvalues thus reducing m to the most significant principal components. As a consequence, the matrix containing the original data can be recalculated in an approximate form (X') devoid of noise and unimportant information.

$$X'(n \times p) = T(n \times m)L^T(m \times p) \quad (13)$$

PCA provides a graphical representation of objects (using the *scores* plot) and of the variables (using the *loadings* plot). The *scores* plot is useful to analyze the behavior of objects highlighting their similarities on the bases of the considered components. In this way, it is possible to identify groups of similar objects (cluster), to ascertain the presence of particular objects (outliers), to evaluate regularity and distributions of the objects.

The *loadings* plot allows to analyze the role of the variables in the different components, their importance and their direct or inverse correlations. Variables that appear close together in the loadings plot indicate that, limited to information carried by these components, they carry information common or similar (i.e. they are directly related). This also applies to variables that appear in a position opposite to each other with respect to the origin: in this case, these variables are inversely related.

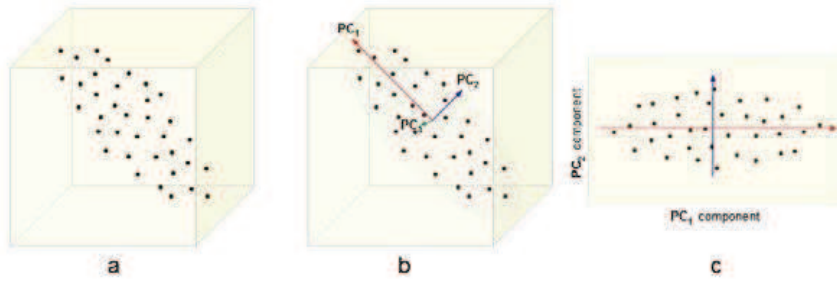

Figure 10. An illustration of PCA: a) a data set given as 3-dimensional points; b) the three orthogonal Principal Components (PCs) for the data, ordered by variance; c) the projection of the data set into the first two PCs, discarding the third one (Kavraki, 2012).

CHAPTER II

2.2 ISO 17043:2010 and the first national ILC

The international standard UNI CEI EN ISO/IEC 17043:2010 “*Conformity assessment-General requirements for proficiency testing*” specifies general requirements for the competence of the organizers of interlaboratory, applicable to all types of ring test.

This document has been prepared by Technical Committee ISO/CASCO "Committee on conformity assessment" in collaboration with Technical Committee CEN/CLC/TC 1 "Criteria for conformity assessment bodies", the secretariat of which is held by BSI.

Interlaboratory comparisons are widely used for a number of purposes and their use is increasing internationally. Typical purposes for interlaboratory comparisons include:

- a) evaluation of the performance of laboratories for specific tests or measurements and monitoring laboratories' continuing performance;
- b) identification of problems in laboratories and initiation of actions for improvement which, for example, may be related to inadequate test or measurement procedures, effectiveness of staff training and supervision, or calibration of equipment;
- c) establishment of the effectiveness and comparability of test or measurement methods;
- d) provision of additional confidence to laboratory customers;
- e) identification of interlaboratory differences;
- f) education of participating laboratories based on the outcomes of such comparisons;
- g) validation of uncertainty claims;
- h) evaluation of the performance characteristics of a method – often described as collaborative trials;
- i) assignment of values to reference materials and assessment of their suitability for use in specific test or measurement procedures;
- j) support for statements of the equivalence of measurements of National Metrology Institutes through “key comparisons” and supplementary comparisons conducted on behalf of the International Bureau of Weights and Measurement (BIPM) and associated regional metrology organizations.

The need for ongoing confidence in laboratory performance is not only essential for laboratories and their customers but also for other interested parties, such as regulators, laboratory accreditation bodies and other organizations that specify requirements for laboratories. There is a growing need for interlaboratory comparisons for other conformity

assessment activities, such as inspection or product certification. Most of the requirements in this International Standard apply to those evolving areas, especially regarding management, planning and design, personnel, assuring quality, confidentiality, and other aspects, as appropriate.

In doing so it replaces both parts of ISO/IEC Guide 43:1997 that included not only guidance on development and operation of interlaboratory comparisons and selection and use of proficiency testing by laboratory accreditation bodies, but also useful descriptions of typical types of proficiency testing. This International Standard has preserved and updated the principles for the operation of proficiency testing described in ISO/IEC Guide 43 and has retained information on typical types of schemes, guidance on appropriate statistical methods, selection and use of interlaboratory comparisons schemes by laboratories, accreditation bodies, regulatory bodies, and other interested parties (ISO/IEC 17043:2010).

The first national ILC (2013) was organized by SAMER, special agency of the Chamber of Commerce of Bari, and RETELAB, the network of the laboratories of the Italian Chambers of Commerce.

The most important aim of the interlaboratory comparison is to highlight the potential of nuclear magnetic resonance spectroscopy ^1H NMR in quantitative analysis. For this purpose it evaluated the performance of different NMR spectrometers about brand, age, and magnetic field.

The present ILC was organized with the aim to set up quality control indicators suitable for multi component quantitative analysis by nuclear magnetic resonance (NMR) spectroscopy. 38 NMR data sets were produced by 33 participants. The calibration line method was chosen for the quantification of a five-component model mixture. Results show that quantitative NMR is a robust quantification tool and that 26 out of 38 data sets resulted in statistically equivalent calibration lines for all considered NMR signals (Gallo et al., 2015). NMR data obtained from laboratories were processed by me in order to validate calculation of all parameters estimate for each signal and participants.

2.2.1 General data and matrix

This ILC was proposed at the III Workshop-Applications of Magnetic Resonance in Food Science-held in Rome (from 28th to 29th May 2012) and at the XLI National Congress on Magnetic Resonance held in Pisa (from 17th to 19th September 2012). General data of this initiative are summarized in the following tables.

Table 2.

Participants	
Registered Participants	36
Available NMR spectrometers	50
Delivered set of samples	38
Spectrometers producing results	33

Table 3.

Magnetic Field (Larmor frequency for ¹H)	
7.1 T (300 MHz)	1
9.4 T (400 MHz)	17
11.7 T (500 MHz)	4
14.1 T (600 MHz)	14
16.4 T (700 MHz)	2

Table 4.

Participant	Laboratory Name
Agilent Italia S.p.a.	
Aptuit S.r.l.	Discovery Analytical Science
Bruker Italia S.r.l.	Laboratorio applicativo NMR
CIRMMMP	FiorGen
CNR – Istituto dei Composti di Chimica Organometallica	
CNR – Istituto di Metodologie Chimiche	Laboratorio di risonanza magnetica "Annalaura Segre"
CNR – Istituto per lo Studio delle Macromolecole	Laboratorio NMR
Consorzio 7C	
CRA	CRA-RPS, Laboratorio di Risonanza Magnetica
ENEA	Laboratorio NMR CR ENEA Trisaia
Innovative Solutions S.r.l. – Spin Off del Politecnico di Bari	
Istituto di ricerche chimiche e biochimiche "G. Ronzoni"	NMR Center
Istituto zooprofilattico sperimentale dell'Abruzzo e del Molise	

Participant	Laboratory Name
Politecnico di Bari	DICATECh – Laboratorio NMR
Università del Salento	DISTeBA – Laboratorio di chimica generale ed inorganica
Università degli Studi dell'Aquila	Dipartimento di Scienze Fisiche e Chimiche – Laboratorio di spettroscopia NMR
Università degli Studi di Bari	Centro interdipartimentale beni culturali
Università degli Studi di Bari	Dipartimento di Chimica AFF
Università degli Studi di Bari	MetalBioLab – Chimica Bioinorganica
Università degli Studi di Bologna	Laboratorio Bio-NMR
Università degli Studi di Cagliari	Laboratorio Interdipartimentale NMR
Università degli Studi di Messina – CNR	Centro NMR Materia Soffice
Università degli Studi di Milano "Bicocca"	Laboratorio NMR
Università degli Studi di Modena e Reggio Emilia	
Università degli Studi di Modena e Reggio Emilia	Laboratorio di chimica degli alimenti Dipartimento di Scienze della Vita
Università degli Studi di Napoli "Federico II"	CERMANU
Università degli Studi di Napoli "Federico II"	Laboratorio Prof. Novellino
Università degli Studi di Padova	Laboratorio Interdipartimentale di Risonanza Magnetica
Università degli Studi di Parma	Laboratorio CIM-tecnopolo
Università degli Studi di Perugia	Laboratorio di chimica metallorganica
Università degli Studi di Roma "Sapienza"	Dipartimento di Chimica Laboratori NMR
Università degli Studi di Roma "Sapienza"	Dipartimento di Chimica Laboratorio NMR
Università degli Studi di Roma "Tor Vergata"	Dipartimento di Scienze e Tecnologie Chimiche – Laboratorio NMR
Università degli Studi di Siena	Dipartimento di Biotecnologie, Chimica e Farmacia
Università degli Studi di Torino	Torino NMR Laboratory
Università degli Studi di Verona	Dipartimento di Biotecnologie – Laboratorio NMR

An appropriate set of secret codes was elaborated and communicated in confidence to each participant. Secret codes refer to spectrometers used by each participant and were not related to the order of presentation of the participants.

Analytes and their concentrations were chosen in order to allow a comparison of different spectrometers by age, brand, hardware, and magnetic field.

The matrix chosen and used for the test was deuterated water D₂O in which were dissolved 4 types of molecules belonging to pesticides category used in agriculture :

Aldicarb - C₇H₁₄N₂O₂S

(2-Methyl-2-(methylthio)propanal O-(N-methylcarbamoyl) oxime) [CAS. N. 116-06-3]

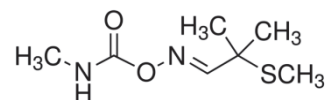

Oxadixyl - C₁₄H₁₈N₂O₄

(2-methoxy-N-(2-oxo-1,3-oxazolidin-3-yl)-acet-2',6'-xylylide) [CAS. N. 77732-09-3]

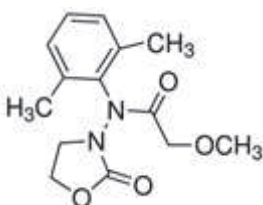

Methamidophos - C₂H₈NO₂PS

(O,S-Dimethyl phosphoramidothioate) [CAS. N. 102658-92-6]

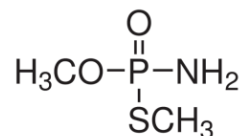

Pirimicarb - C₁₁H₁₈N₄O₂

[(2-Dimethylamino-5,6-dimethylpyrimidin-4-yl) N,N-dimethylcarbamate] [CAS. N. 23103-98-2]

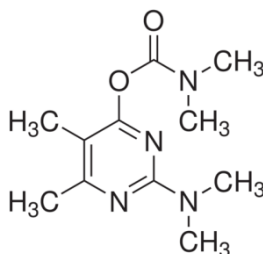

Preliminarily, each active principle was tested in solution, making qualitative and quantitative analysis. This study has allowed the selection of the signals of each analyte for the estimation of the application field and the limit of quantification (LOQ).

Table 5

Active Principle	Chemical Shift (δ)	Signal Code
Aldicarb	1.48	A1
	2.80	A2
	7.74	A3
Methamidophos	3.77	M1
Oxadixyl	3.34	O1
	7.50-7.16	O2
Pirimicarb	3.02	P1
	3.15	P2

.....

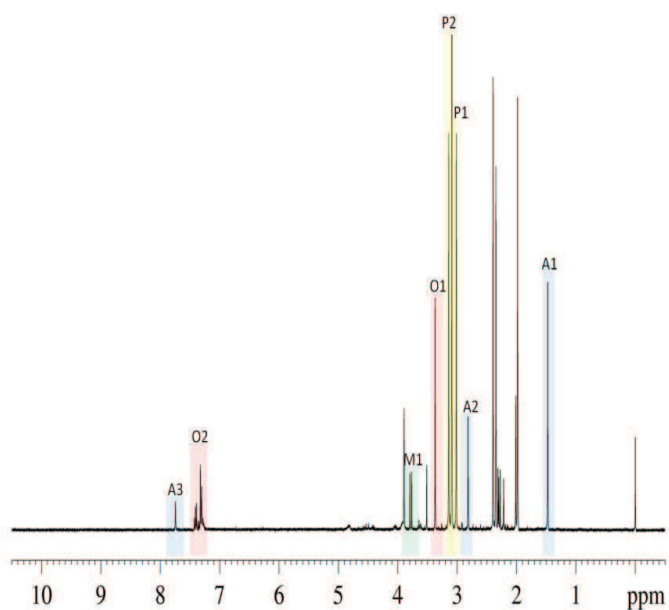

Figure 11. Spectrum ¹HNMR

Moreover, the preliminary study was necessary in order to define the analytical protocol "Instructions for NMR experiments " that explain the experimental instructions and acquisition parameters that were observed during this comparison.

2.2.2 Samples preparation

All samples were prepared by qualified personnel. With the active principles, two solutions were prepared :

- the first for the preparation of known concentration samples and defined uncertainty for calibration curve construction
- the second solution at unknown concentrations (however comprised in the scope of the method) for the realization of this ILC.

In all solutions it was added an internal reference standard: 3-(trimethylsilyl)-2,2,3,3-tetradeutero-propionic acid sodium salt (below called TSP), which is useful for estimating the homogeneity of the magnetic field for individual experiments and to set the zero on the scale of the chemical shift. Each solution was first homogenized and subsequently transferred (1 ml) in NMR tubes .

The homogeneity of the entire batch of samples, was verified before sending them to the participants.

2.2.3 Preparation of blank

The blank consisted of an aliquot of deuterated water, used for the preparation of the solutions, contained TSP in a concentration of 20.33 mg / L.

2.2.4 Standards preparation

The solutions of known concentration were prepared from certified powders of standard of pure pesticides with a purity greater than or equal to 98.5%.

The method of preparation of solutions for instruments calibration is called "gravimetric", because for the preparation of the solutions, powder of certified reference material and the solvent (D₂O containing TSP) were weighed on calibrated and certified balance, and added to the solutions. This operations were carried out in air-conditioned environment (20° C +/- 5° C) and thermohygrometric controlled. For an accurate and precise dosage of the solvent, by density value, it was added the equivalent of the gravimetric volume of the solvent needed to bring solutions to the designated concentrations.

Weighing was performed with an analytical scale KERN ABT 100-5M, weighing range 1mg-100.000mg (readability = 0.01 mg, 0.05mg reproducibility). This balance is subject to regular internal calibration performed with certified weight set KERN DKD-K-11801, 11/06, s / n G0703552.

The glassware was of class A, although the measurements weren't volumetric.

The calculation of the uncertainty (according to the guidelines EURACHEM / CITAC) takes into account: the uncertainty of the calibration of the balance (used to make solutions), the number of weighs (including "tare"), the purity of starting materials and the evaluation of density of the solvent. The contributions of uncertainty, relativized and squared, are added. The sum is subsequently placed under the root and the result is multiplied by the cover factor (k = 2); the value is then multiplied by the obtained gravimetric concentration (expanded and absolute uncertainty).

2.2.5 Preparation of solutions for calibration curves construction

A concentrated mother solution was prepared (see above) for all the a.p. (active principle below) chosen, in order to make one single addition, exclusively truthful using volumetric glassware of class A, to obtain the predetermined concentration, in mg / L, on the matrix.

The diluted solutions were prepared for subsequent addition of deuterated water, always gravimetrically. 1 ml of each solution was poured into the NMR tubes and each of these was labeled in the following way.

Table 6. Standard solutions for calibration curve construction.

TUBE	ACTIVE PRINCIPLE	DECLARED CONCENTRATION	DECLARED UNCERTAINTY		
A	ALDICARB	498,32	±	6,28	mg/l
	OXADIXYL	500,44	±	6,31	mg/l
	METHAMIDOPHOS	501,23	±	6,32	mg/l
	PIRIMICARB	498,72	±	6,28	mg/l
B	ALDICARB	249,67	±	3,2	mg/l
	OXADIXYL	250,73	±	3,21	mg/l
	METHAMIDOPHOS	251,13	±	3,25	mg/l
	PIRIMICARB	249,87	±	3,2	mg/l
C	ALDICARB	125,91	±	1,64	mg/l
	OXADIXYL	126,45	±	1,64	mg/l
	METHAMIDOPHOS	126,65	±	1,65	mg/l
	PIRIMICARB	126,01	±	1,64	mg/l
D	ALDICARB	62,47	±	0,82	mg/l
	OXADIXYL	62,74	±	0,83	mg/l
	METHAMIDOPHOS	62,84	±	0,84	mg/l
	PIRIMICARB	62,52	±	0,83	mg/l
E	ALDICARB	31,23	±	0,42	mg/l
	OXADIXYL	31,36	±	0,42	mg/l
	METHAMIDOPHOS	31,41	±	0,43	mg/l
	PIRIMICARB	31,25	±	0,42	mg/l

2.2.6 Preparation of unknown concentration solution

The unknown solution, containing the four a.p., was made with the same gravimetric method, by preparing concentrated solutions and diluting them gravimetrically, in order to obtain the unknown titles in mixture (D₂O solvent containing the TSP).

2.2.7 Samples delivery

Samples were sent (12.02.2013) by an express courier guaranteeing delivery within two days. Each pack contained:

- a tube of "blank";
- 5 tubes of solution with increasing concentration for the construction of the calibration curves;
- a tube of unknown concentration solution of the mixture of a.p.

All samples were properly packaged in shockproof material; the delivery in controlled temperature conditions was not considered necessary.

2.2.8 Calibration curve

Each participant had analyzed, as described in the analytical protocol "Instructions NMR experiments", the tubes labeled with A-B-C-D-E-F - BLANK at different times, in order to obtain three calibration curves, so mentioned below:

- (123) curve constructed with the analysis carried out in triplicate during the same day ;
- (145) curve constructed with the analysis carried out in triplicate at a distance of at least 24 h (4) and at least 48h (5) from the experiments of the first day (1);
- (12345) curve constructed with all experiments.

2.2.9 Data set

Each laboratory had made the experiments under repeatability conditions following the "Instructions NMR experiments".

The homogeneous processing of spectra and the a.p. quantitative analysis were performed. The following table summarizes the list of a.p. and the concentration value of the unknown sample obtained by averaging the estimated results by excluding outliers with statistical applied tests, at 95 % of probability.

The value was obtained by integrating signals of the spectrum for the same a.p. and calculating the relative concentrations by three different calibration curves.

Table 7. Values of average concentration for each a.p.

Active Principle	Chemical shift (δ)	Signal Label (Fig. 11)	Curves		
			123 Conc. (mg/L)	145 Conc. (mg/L)	12345 Conc. (mg/L)
Aldicarb	1.48	A1	94.74	94.75	94.78
	2.80	A2	95.83	95.75	95.63
	7.74	A3	94.12	93.89	94.06
Methamidophos	3.77	M1	70.74	70.55	70.49
Oxadixyl	3.34	O1	282.53	282.22	282.45
	7.50-7.16	O2	284.00	284.00	284.69
Pirimicarb	3.02	P1	415.66	414.36	414.56
	3.15	P2	418.34	419.15	418.94

2.2.10 Statistical elaboration and results

On results, statistical tests for the presence of outliers have been performed. Cochran, Grubbs single observation, Grubbs double observation and Huber tests were made to check abnormal data on the uncertainty of measurement. Anomalous results, with the probability of 95%, were excluded from the population of the data set. Subsequently, on the data population except from outliers, were applied in the order:

- Shapiro – Wilk test
- Assessment of anomalous data (Grubbs single observation, Grubbs double observation and Huber tests).

Even in this case anomalous results, with the probability of 95%, were excluded from the population of the data set. Concentrations thus obtained were used to calculate parameters listed in the following table:

Table 8.

<i>Total number of data sets (n)</i>
<i>Average(X_m)</i>
<i>Variance (Sr^2)</i>
<i>Standard deviation (Sr)</i>
<i>CV%</i>
<i>Minimum (Min)</i>
<i>Maximum (Max)</i>
<i>Range</i>
<i>Median</i>
<i>Minimum confidence limit ($p = 0,95$)</i>
<i>Maximum confidence limit ($p = 0,95$)</i>
<i>Confidence interval ($p = 0,95$)</i>
<i>Degrees of freedom ($v-1$)</i>
<i>Student's T ($v = n-1; p = 0,95$)</i>
<i>Reproducibility limit of method (r)</i>

For all participants of this ILC, it was made the calculation of the Z-score, considering the average concentration (C_m) and the uncertainty of measurement (Sr_m) without outliers with the probability of 95 %

$$Z\text{-score} = (C_i - C_m) / Sr_m$$

(14)

Comparing this value, each laboratory could evaluated their own instrumental performance.

2.2.11 Final comments

From the evaluation of results, the high performances of NMR spectrometers used in this interlaboratory comparison are evident. In particular, the close and intermediate repeatability, by the performance using 123, 145 and 12345 calibration curves, indicate that the quantitative determinations of the active principles may be reliably reproduced by different NMR spectrometers. Considering the values of CV% (the ratio expressed as a percentage of the standard deviation and the average concentrations) calculated by taking the average concentration obtained from each spectrometer, it is possible to see that the highest value (3.7) is well below the maximum acceptable value (10.0 from "AOAC Guidelines for single laboratory validation of chemical methods for dietary supplements and botanicals, 2002") for the concentrations considered in the interlaboratory comparison.

By this result, the main objective of the interlaboratory comparison, to disclose the reliability of ^1H NMR spectroscopy in quantitative analysis to technicians working in a different context from the academic one, was achieved with success and it has exceeded the expectations of the promoters.

CHAPTER III

2.3 Validation of tests and calculation

In this context my work is consisted in the validation of calculation of all parameters, estimated for each signal and participants of the first national ILC, by processing data on Excel worksheet. The parameters that I considered are:

- Cochran Test
- Huber Test
- Average of Averages
- Maximum Value
- Minimum Value
- Range
- Median
- Degrees of Freedom
- Interlaboratory Standard Deviation
- Coefficient of Variation
- Repeatability Variance
- Variance Interlaboratory
- Variance of Reproducibility
- Lower Confidence Limit
- Upper Confidence Limit
- Confidence Range
- Reproducibility Limit

In order to achieve validation, a table containing the integrals of each signal (average, standard deviation and R^2), was built for all 36 laboratories of the ILC (see table 9 below).

Table 9.

Lab	ALDICARB 1,48			ALDICARB 2,80			ALDICARB 7,74			METHAMIDOPHOS 3,77			OXADIXIL 3,34			OXADIXIL 7,50-7,16			PIRIMICARB 3,02			PIRIMICARB 3,15		
	AV.	St.D	R ²	AV	St.D	R ²	AV	St.D	R ²	AV	St.D	R ²	AV	St.D	R ²	AV	St.D	R ²	AV	St.D	R ²	AV	St.D	R ²
01	94,82	1,69	0,999	94,86	2,11	0,999	96,24	3,96	0,999	56,69	0,47	0,990	287,9	1,3	0,999	289,5	5,2	0,996	416,6	6,9	0,998	429,4	1,7	0,998
02	98,99	7,33	0,986	92,78	5,74	0,988	104,56	7,53	0,989	72,27	4,27	0,989	273,2	21,0	0,987	283,9	26,5	0,977	398,8	30,3	0,988	398,6	30,7	0,989
03	92,89	2,95	0,991	95,85	2,68	0,991	90,71	4,29	0,992	66,49	2,47	0,991	284,3	10,9	0,990	287,2	9,7	0,991	420,9	12,0	0,992	420,8	18,5	0,990
04	99,55	10,95	0,989	102,86	11,24	0,989	93,05	11,39	0,990	71,36	7,68	0,989	302,3	32,7	0,989	307,0	32,7	0,989	450,5	47,7	0,989	452,1	48,3	0,989
06	80,24	7,41	0,893	86,00	7,05	0,898	89,40	6,60	0,930	51,26	5,53	0,894	305,3	19,6	0,897	321,9	16,8	0,934	455,6	32,8	0,891	479,1	31,8	0,890
07	86,42	2,34	0,982	89,60	3,93	0,981	84,97	3,24	0,983	52,18	1,95	0,984	290,8	9,1	0,981	305,0	11,3	0,985	439,3	10,1	0,983	443,0	8,3	0,983
08	97,27	9,66	0,983	98,14	10,19	0,984	94,42	9,77	0,879	67,50	8,11	0,936	343,6	24,0	0,935	348,7	26,0	0,932	498,4	32,9	0,928	523,8	34,9	0,971
09	90,89	9,58	0,985	94,04	8,43	0,985	90,83	14,26	0,983	64,53	8,91	0,985	292,1	35,3	0,984	295,9	35,4	0,983	441,4	39,9	0,984	440,6	55,3	0,985
11	96,51	12,20	0,987	99,04	11,08	0,987	110,97	15,42	0,989	76,81	7,56	0,988	254,7	21,4	0,987	271,3	17,9	0,989	368,5	54,8	0,985	391,1	61,6	0,985
12	97,09	0,65	0,999	96,11	0,81	0,999	95,48	0,77	0,999	71,61	0,57	0,999	289,8	2,1	0,999	292,1	1,7	0,999	427,6	2,6	0,999	430,6	2,5	0,999
13	90,78	2,19	0,990	91,94	2,21	0,995	93,55	1,98	0,993	61,53	2,09	0,974	287,9	5,4	0,997	281,5	4,3	0,987	421,3	9,8	0,993	424,0	9,1	0,988
15	94,32	4,63	0,996	91,28	7,94	0,995	98,60	8,46	0,997	74,37	1,54	0,998	282,7	4,2	0,998	284,5	14,0	0,988	400,0	28,5	0,990	431,2	14,2	0,995
17	95,54	3,16	0,998	97,67	3,17	0,998	94,71	4,60	0,998	70,18	2,52	0,998	281,8	10,4	0,998	283,0	9,8	0,998	413,1	13,6	0,998	416,4	14,2	0,998
18	101,02	12,29	0,986	102,85	13,79	0,995	101,18	11,84	0,987	61,67	8,72	0,869	302,0	33,4	0,995	308,0	27,3	0,981	473,6	62,6	0,995	460,8	55,6	0,982
19	96,32	0,95	0,999	94,84	1,07	0,999	97,53	1,77	0,999	55,35	1,12	0,983	284,0	3,8	0,999	289,1	3,1	0,999	423,6	2,7	0,998	425,6	6,7	0,998
20	97,37	0,83	0,980	98,52	1,41	0,980	95,81	0,72	0,981	68,73	0,64	0,980	304,9	2,5	0,981	307,5	3,4	0,981	454,1	4,9	0,980	455,4	2,7	0,982
21	96,11	0,95	0,999	96,30	0,63	0,999	94,70	3,02	0,999	68,11	0,60	0,999	288,4	4,0	0,999	289,8	4,6	0,999	424,4	4,0	0,999	426,0	5,0	0,999
22	95,09	2,73	0,998	96,03	4,05	0,998	93,21	7,45	0,996	62,98	3,96	0,996	288,1	9,9	0,998	291,5	8,0	0,997	433,7	12,5	0,998	438,7	2,3	0,997
23	92,35	1,33	0,999	92,19	0,60	0,9997	87,74	1,93	0,999	67,82	1,21	0,999	268,8	4,1	0,999	268,7	3,7	0,993	405,5	4,2	0,999	407,5	11,5	0,999
24	90,54	3,20	0,987	90,53	4,08	0,9870	91,12	2,55	0,989	67,66	2,25	0,987	264,2	8,8	0,988	266,4	9,7	0,987	387,3	14,3	0,98	390,4	11,8	0,991
25	95,95	4,47	0,999	97,38	4,58	0,9992	95,36	3,28	0,999	69,59	3,44	0,999	277,7	13,0	0,999	280,7	13,0	0,999	406,0	19,9	0,999	410,6	18,9	0,999
26	95,15	2,59	0,999	94,39	2,65	0,9992	94,76	2,67	0,999	71,46	1,65	0,999	281,8	6,7	0,999	281,4	7,9	0,999	409,2	11,3	0,999	413,4	10,4	0,999
27	95,76	2,99	0,995	95,54	3,45	0,9955	94,27	1,26	0,996	69,53	2,18	0,996	272,4	8,2	0,996	274,2	8,9	0,996	395,4	13,5	0,994	402,5	11,9	0,997
28	114,82	10,98	0,983	112,87	11,61	0,9834	113,68	9,38	0,984	79,41	7,74	0,983	372,3	32,4	0,982	373,7	33,5	0,983	550,1	49,2	0,982	558,6	46,1	0,984
29	95,28	3,10	0,990	97,63	5,12	0,9917	93,65	1,34	0,991	70,18	2,15	0,992	278,9	7,1	0,991	282,6	10,0	0,991	415,7	19,3	0,991	409,5	6,3	0,992
30	99,23	1,49	0,997	106,59	4,30	0,9972	92,75	2,99	0,997	73,29	0,42	0,998	286,5	5,2	0,998	299,8	4,2	0,997	441,7	8,1	0,997	424,2	3,9	0,997
32	148,48	65,30	0,973	155,87	74,52	0,9729	137,73	51,71	0,976	115,63	51,99	0,973	427,8	196,8	0,974	425,8	193,9	0,973	623,6	300,3	0,972	623,7	277,3	0,975
33	88,93	10,28	0,966	90,47	12,15	0,9655	88,02	6,77	0,969	68,79	8,33	0,963	240,5	31,0	0,966	239,0	32,3	0,965	342,2	48,7	0,964	348,9	44,2	0,967
34	98,47	2,30	0,988	103,03	2,61	0,9863	100,97	2,01	0,988	74,15	1,56	0,987	278,7	7,0	0,988	280,2	7,8	0,987	403,4	10,4	0,987	404,4	11,1	0,987
35	94,66	1,04	0,996	94,41	1,13	0,9966	92,21	4,70	0,996	70,18	0,65	0,996	284,9	3,0	0,996	287,9	3,5	0,996	422,3	5,0	0,996	420,1	4,5	0,997
36	91,01	0,82	0,998	90,62	1,31	0,9978	89,42	2,37	0,996	65,35	1,76	0,998	261,0	3,0	0,998	284,1	4,7	0,996	378,2	7,3	0,996	382,6	9,4	0,998
56	95,50	0,88	0,999	97,09	1,07	0,9998	90,07	8,38	0,998	67,37	1,71	0,998	284,8	1,7	0,999	285,5	9,0	0,998	417,2	4,8	0,999	434,9	4,6	0,998
59	98,29	3,62	0,994	100,16	5,72	0,9948	96,69	6,41	0,970	72,35	3,28	0,995	279,9	9,6	0,996	277,8	14,0	0,991	406,2	20,2	0,993	421,7	16,8	0,996
60	89,37	3,33	0,986	90,72	4,56	0,9858	91,29	3,40	0,988	68,26	2,04	0,986	253,0	7,4	0,988	255,3	9,6	0,986	371,1	16,3	0,984	373,5	9,3	0,990
60bis	87,91	2,82	0,978	87,69	3,47	0,9791	88,19	2,45	0,979	67,59	2,08	0,979	244,4	7,5	0,979	245,3	9,7	0,979	351,5	15,1	0,978	359,8	8,7	0,979
61	102,66	1,88	0,992	97,81	4,14	0,9923	107,66	3,43	0,993	74,88	1,42	0,992	288,0	4,6	0,992	282,7	8,8	0,99	422,7	11,3	0,990	433,9	13,2	0,993

2.3.1 Validation of Cochran test

The Cochran test, used to check abnormal data, could be applied, as required by Community standard UNI ISO 5725-2 section 7.3.3, strictly if standard deviations are all calculated with the same number n of results obtained under repeatability conditions.

Validation of Cochran test was performed by making an Excel worksheet. For each signal the average of averages, and the standard deviation of averages were calculated using Excel functions, respectively as $\bar{x} = + \text{MEDIA}$ and $s_x = + \text{DEV.ST.}$

In relation to the columns of the standard deviation of each laboratory, following parameters were calculated for each signal:

-*maximum* value of standard deviations of each laboratory;

- $\Sigma(U^2)$: sum of squared deviations of each laboratory;

- n : total number of not excluded laboratories;

- C : ratio between the square of the maximum and the sum of squares of the deviations of each laboratory;

-*number of data* that were removed by Cochran test.

Then, for each signal, values have been ordered increasingly, using as a reference the standard deviation column of the relative signal.

The test shall satisfy this equation :

If $C \leq C_{TAB}$ data analyzed is not abnormal;

If $C > C_{TAB}$ data analyzed is abnormal and should be deleted from the table.

The values of C_{TAB} were extrapolated from paragraph 8.1 of the community standard UNI ISO 5725-2 (table 10, column $n=5$ at 5%, because replicates of interlaboratory comparison were 5).

We have considered C_{TAB} tabulated values relative to the total number of laboratories that are not eliminated.

Table 10. Cochran test tabulated values

n	C_{TAB}
24	0.166
25	0.160
26	0.155
27	0.150
28	0.146
29	0.142
30	0.138
31	0.134
32	0.131
33	0.127
34	0.124
35	0.121
36	0.118

The value of C was compared with C_{TAB}. If the higher standard deviation was classified as outlier, it would be omitted and the test would be repeated on remaining values until abnormal data would be all deleted from the population.

In the following table is possible see laboratories that were excluded by Cochran test, highlighted in green.

Table 11.

Name/Lab	ALDICARB 1,48			ALDICARB 2,80			ALDICARB 7,74			METHAMIDOPHOS 3,77			OXADIXYL 3,34			OXADIXYL 7,50-7,16			PIRIMICARB 3,02			PIRIMICARB 3,15		
	Av.	St. D	R ²	Av.	St. D	R ²	Av.	St. D	R ²	Av.	St. D	R ²	Av.	St. D	R ²	Av.	St. D	R ²	Av.	St. D	R ²	Av.	St. D	R ²
Lab 01	94,82282	1,687434	0,998998	94,85708	2,114318	0,999283	96,24442	3,959086	0,999179	56,6943	0,465447	0,990695625	287,9401	1,292666	0,999332	289,5048	5,184671	0,996636	416,6184	6,913338	0,998888	429,43	1,719615	0,998407
Lab 02				92,77639	5,741362	0,98871	104,5572	7,525264	0,989563															
Lab 03	92,88792	2,951422	0,991847	95,85401	2,677001	0,991659	90,70781	4,289873	0,992315	66,48807	2,468758	0,991497056	284,2979	10,93	0,990942	287,232	9,655098	0,991082	420,9285	11,98747	0,992027	420,8	18,49919	0,990035
Lab 04																								
Lab 06				86,00114	7,052927	0,898582	89,40122	6,60094	0,92998							321,8904	16,75258	0,93446						
Lab 07	86,4197	2,337392	0,982463	89,60058	3,931929	0,981016				52,1771	1,94964	0,984031052	290,7764	9,136839	0,981828	304,9623	11,28455	0,98588	439,2882	10,06719	0,983433	443,0317	8,340904	0,983375
Lab 08							94,42185	9,768839	0,879174															
Lab 09																								
Lab 11																271,2657	17,87663	0,989292						
Lab 12	97,09302	0,652717	0,999915	96,11081	0,813109	0,99989	95,48433	0,770298	0,999874	71,6092	0,56587	0,999922234	289,7931	2,053477	0,999915	292,0735	1,692824	0,999886	427,5937	2,590051	0,999811	430,5612	2,538579	0,999753
Lab 13	90,77732	2,194933	0,990344	91,94485	2,211607	0,995577	93,55193	1,97921	0,993898	61,53406	2,090823	0,974650833	287,867	5,412339	0,997704	281,5248	4,298169	0,98705	421,291	9,785391	0,9934	424,05	9,090606	0,988535
Lab 15	94,3236	4,631247	0,996881				98,59527	8,45932	0,99773	74,37403	1,543065	0,998126106	286,7258	4,245424	0,998681	284,5359	14,01953	0,988473				431,2041	14,15822	0,99514
Lab 17	95,5355	3,158728	0,998852	97,66654	3,16787	0,998757	94,70642	4,603407	0,998733	70,1758	2,520252	0,998817698	281,8052	10,38504	0,998752	282,9886	9,771698	0,998746	413,0553	13,55072	0,998737	416,3862	14,17911	0,99874
Lab 18																								
Lab 19	96,31741	0,946299	0,99955	94,84419	1,067908	0,999242	97,5305	1,766076	0,999132	55,35415	1,117252	0,983360287	284,0103	3,803585	0,999776	289,095	3,147117	0,999714	423,6161	2,737172	0,998526			
Lab 20	97,36599	0,829505	0,980719	98,51796	1,412075	0,980836	95,80606	0,717038	0,981707	68,72596	0,638093	0,98085132	304,9407	2,452488	0,981641	307,5206	3,403345	0,981228	454,1148	4,888555	0,980263	455,4163	2,689736	0,98222
Lab 21	96,10607	0,954678	0,999368	96,30299	0,633388	0,999303	94,69722	3,015061	0,999605	68,11234	0,604068	0,999112027	288,3962	3,952828	0,999455	289,8272	4,598807	0,999073	424,4245	4,016007	0,999494	426,022	4,999572	0,999285
Lab 22	95,09143	2,728212	0,998402	96,03216	4,047505	0,998312	93,21277	7,446187	0,996484	62,97648	3,962387	0,996522112	288,1425	9,871714	0,998051	291,5165	8,041493	0,997293	433,6787	12,50977	0,998198	438,6805	2,303907	0,997528
Lab 23	92,35237	1,330445	0,999829	92,18831	0,596967	0,999667				67,82344	1,210618	0,999272947	268,8423	4,127307	0,999803	268,6698	3,698228	0,993731	405,497	4,24238	0,99952	407,5384	11,45735	0,999389
Lab 24	90,54473	3,200774	0,987749	90,52919	4,077301	0,986973	91,11802	2,552239	0,989084	67,66498	2,252637	0,987860232	264,2141	8,822097	0,998756	266,4048	9,709004	0,987834	387,3358	14,34324	0,98524	390,4282	11,83164	0,99192
Lab 25	95,95415	4,466521	0,999253	97,38186	4,57889	0,99918	95,35869	3,283128	0,999038	69,58882	3,437032	0,999144847	277,6526	13,02805	0,999093	280,6577	13,04856	0,999131	406,0499	19,87697	0,999113	410,6469	18,85983	0,99912
Lab 26	95,15052	2,59326	0,999291	94,3906	2,652586	0,999155	94,7637	2,66805	0,999315	71,4571	1,651842	0,999266121	281,7742	6,74605	0,999484	281,3868	7,906486	0,999273	409,2484	11,31262	0,999228	413,4493	10,37624	0,999313
Lab 27	95,7624	2,989227	0,995738	95,53786	3,445421	0,995497	94,26934	1,258355	0,996603	69,52822	2,178242	0,996212983	272,4276	8,22679	0,996589	274,1669	8,889261	0,995976	395,4061	13,49262	0,994097	402,4713	11,87676	0,997088
Lab 28							113,6799	9,377142	0,984051															
Lab 29	95,28013	3,098271	0,990713	97,62695	5,120154	0,991717	93,65408	1,338904	0,991505	70,18108	2,152805	0,99206917	278,8576	7,064433	0,991504	282,6174	10,04637	0,991121	415,6643	19,33325	0,991172	409,464	6,29086	0,992828
Lab 30	99,22817	1,486594	0,99782	106,5907	4,30413	0,997161	92,75296	2,986384	0,997613	73,29112	0,417308	0,998041839	286,5239	5,171609	0,998052	299,8108	4,220133	0,997711	441,7339	8,141481	0,997834	424,2302	3,934461	0,997859
Lab 32																								
Lab 33							88,02007	6,771762	0,969328															
Lab 34	98,47194	2,298105	0,988147	103,0345	2,606817	0,986313	100,9727	2,013315	0,98846	74,14839	1,559595	0,987726918	278,6539	7,002975	0,988143	280,173	7,781927	0,987913	403,3998	10,38335	0,987249	404,4016	11,08243	0,98773
Lab 35	94,66292	1,035387	0,996624	94,41022	1,126998	0,996565				70,17521	0,653773	0,996682412	284,9019	2,990338	0,996789	287,9421	3,542429	0,996627	422,2932	4,976809	0,996437	420,1033	4,462539	0,997226
Lab 36	91,00635	0,8221	0,998213	90,62134	1,308987	0,997781	89,41819	2,373128	0,996414	65,35392	1,758941	0,997991706	261,0113	3,002634	0,998326	284,1115	4,678937	0,996509	378,2183	7,29247	0,996909	382,64	9,414744	0,997995
Lab 56	95,49856	0,8847	0,999728	97,091	1,066576	0,999757	90,07073	8,377518	0,998501	67,37218	1,706219	0,99882679	284,7729	1,727691	0,999351	285,5173	8,974194	0,998384	417,2328	4,802607	0,999603	434,8571	4,592674	0,998578
Lab 59	98,28988	3,62028	0,99433	100,1637	5,724336	0,994848	96,68778	6,4109	0,97066	72,34591	3,276258	0,995354241	279,9082	9,600236	0,996254	277,8368	14,02992	0,991402	406,2156	20,16647	0,993139	421,6549	16,84926	0,995957
Lab 60	89,37291	3,326922	0,986297	90,71891	4,555369	0,985754	91,2858	3,395039	0,987974	68,26083	2,044657	0,986906194	252,9552	7,425797	0,988137	255,263	9,553601	0,986347	371,0916	16,26494	0,984515	373,5432	9,335594	0,990218
Lab 60 BIS	87,91484	2,818509	0,97854	87,69279	3,472797	0,979061	88,19208	2,447748	0,979445	67,59462	2,075551	0,97952447	244,3535	7,549939	0,979298	245,3296	9,729952	0,979843	351,5116	15,0916	0,978902	359,7939	8,728538	0,979792
Lab 61	102,6641	1,881194	0,992118	97,81434	4,14067	0,992262	107,6566	3,434177	0,993679	74,87807	1,416031	0,992358288	287,981	4,556011	0,992457	282,7187	8,770087	0,991869	422,7082	11,31797	0,990656	433,9393	13,20476	0,993615

The test, as far as concerned the deleted value of signals Aldicarb 1.48, Aldicarb 2.80, Methamidophos 3.37, Oxadixil 3.34, Oxadixil 7.50-7.16, Pirimicarb 3.02, was coincident with that made by the electronic platform developed for the interlaboratory comparison. But in the case of signal Aldicarb 7.74, abnormal values calculated using Excel are 5 instead of 8. These 5 values shall be add to the 3 laboratories (Lab 07, Lab23, Lab35 marked in blue in table 11) that didn't correctly deliver results (the number of replies sent was less than 5). Thus a total of 8 eliminated outliers was obtained in accordance with the platform of the comparison. A similar procedure was performed for the signal Pirimicarb 3.15. Lab 19 must be added to the 10 outliers, obtaining a total of 11 deleted data. Cochran test was so validated.

Table 12.

<i>Signal</i>	<i>n. Cochran Outliers</i>	<i>Lab Code Cochran Outliers</i>	<i>n. excluded lab for incorrect delivered data</i>	<i>Lab Code excluded lab</i>	<i>Tot deleted data</i>
Aldicarb 1.48	10	Lab02- Lab04-Lab06- Lab08-Lab09-Lab11- Lab18-Lab28-Lab32-Lab33	-	-	10
Aldicarb 2.80	9	Lab04-Lab08-Lab09- Lab11-Lab15-Lab18- Lab28-Lab32-Lab33	-	-	9
Aldicarb 7.74	5	Lab04-Lab09-Lab11- Lab18-Lab32	3	Lab07- Lab23- Lab35	8
Methamidophos 3.77	10	Lab02-Lab04-Lab06- Lab08-Lab09-Lab11- Lab18-Lab28-Lab32-Lab33	-	-	10
Oxadixyl 3.34	10	Lab02-Lab04-Lab06- Lab08-Lab09-Lab11- Lab18-Lab28-Lab32-Lab33	-	-	10
Oxadixyl 7.50-7.16	8	Lab02-Lab04-Lab08- Lab09-Lab18-Lab28- Lab32-Lab33	-	-	8
Pirimicarb 3.02	11	Lab02-Lab04-Lab06- Lab08-Lab09-Lab11- Lab15-Lab18-Lab28- Lab32-Lab33	-	-	11
Pirimicarb 3.15	10	Lab02-Lab04-Lab06- Lab08-Lab09-Lab11- Lab18-Lab28-Lab32-Lab33	1	Lab19	11

2.3.2 Validation of Huber test

Huber test was performed on the population free from Cochran outliers. According to the Manual UNICHIM 179-1 Ed.2001, verification of Huber is based on the properties of the median and the number of deleted data is not predetermined.

A table containing the average of each laboratory for each signal was made on an Excel sheets. Later continued as follows :

- to sort in ascending order $x_1 < x_2 < x_3 \dots < x_n$;
- to calculate the median averages (Me);
- to calculate in absolute value the difference between each data and the median (Dn);
- to sort in ascending order the obtained values;
- to calculate the median of these differences ($Me\Delta$);
- to multiply the median for the critical value 4.5.

Huber test must satisfy this equation:

If $Dn > 4.5 Me\Delta$, the analyzed data is abnormal and should be removed from the table.

Table 13.

Signal	Outliers number	Lab Code
Aldicarb 1.48	0	--
Aldicarb 2.80	1	Lab30
Aldicarb 7.74	2	Lab28 - Lab61
Methamidophos 3.77	3	Lab01 - Lab07 - Lab19
Oxadixyl 3.34	5	Lab20 - Lab24 - Lab36 - Lab60- Lab60bis
Oxadixyl 7.50-7.16	3	Lab06 - Lab60 - Lab60bis
Pirimicarb 3.02	1	Lab60bis
Pirimicarb 3.15	1	Lab60bis

The number of outliers is coincident with the number made by the electronic platform developed for the interlaboratory comparison.

At the end we obtained a summary table containing all the data not excluded by Cochran (in green) and Huber tests (in orange).

Table 14.

NameLab	ALDICARB 1,48			ALDICARB 2,80			ALDICARB 7,74			METHAMIDOPHOS 3,77			OXADIXYL 3,34			OXADIXYL 7,50-7,16			PIRIMICARB 3,02			PIRIMICARB 3,15			
	AV	St.D	R ²	AV	St.D	R ²	AV	St.D	R ²	AV	St.D	R ²	AV	St.D	R ²	AV	St.D	R ²	AV	St.D	R ²	AV	St.D	R ²	
Lab 01	94,82282	1,687434	0,998998	94,857078	2,114318	0,999283	96,24442	3,959086	0,999179				287,94007	1,292666	0,999332	289,50481	5,184671	0,996636	416,61836	6,913338	0,998888	429,43002	1,719615	0,998407	
Lab 02				92,776386	5,741362	0,98871	104,5572	7,525264	0,989563																
Lab 03	92,88792	2,951422	0,991847	95,854013	2,677001	0,991659	90,70781	4,289873	0,992315	66,48807	2,468758	0,991497	284,2979	10,93	0,990942	287,23198	9,655098	0,991082	420,92855	11,98747	0,992027	420,80004	18,49919	0,990035	
Lab 04																									
Lab 06				86,00114	7,052927	0,898582	89,40122	6,60094	0,92998																
Lab 07	86,4197	2,337392	0,982463	89,600581	3,931929	0,981016							290,77636	9,136839	0,981828	304,96232	11,28455	0,98588	439,28821	10,06719	0,983433	443,03168	8,340904	0,983375	
Lab 08							94,42185	9,768839	0,879174																
Lab 09																									
Lab 11																271,26571	17,87663	0,989292							
Lab 12	97,09302	0,652717	0,999915	96,110812	0,813109	0,99989	95,48433	0,770298	0,999874	71,6092	0,56587	0,999922	289,79315	2,053477	0,999915	292,07355	1,692824	0,999886	427,59365	2,590051	0,999811	430,56124	2,538579	0,999753	
Lab 13	90,77732	2,194933	0,990344	91,944846	2,211607	0,995577	93,55193	1,97921	0,993898	61,53406	2,090823	0,974651	287,86695	5,412339	0,997704	281,52484	4,298169	0,98705	421,29101	9,785391	0,9934	424,04999	9,090606	0,988535	
Lab 15	94,3236	4,631247	0,996881				98,59527	8,45932	0,997773	74,37403	1,543065	0,998126	286,72581	4,245424	0,998681	284,53586	14,01953	0,988473				431,20411	14,15822	0,99514	
Lab 17	95,5355	3,158728	0,998852	97,666535	3,16787	0,998757	94,70642	4,603407	0,998733	70,1758	2,520252	0,998818	281,80523	10,38504	0,998752	282,98856	9,771698	0,998746	413,05531	13,55072	0,998737	416,38619	14,17911	0,99874	
Lab 18																									
Lab 19	96,31741	0,946299	0,99955	94,844189	1,067908	0,999242	97,5305	1,766076	0,999132				284,0103	3,803585	0,999776	289,09499	3,147117	0,999714	423,61609	2,737172	0,998526				
Lab 20	97,36599	0,829505	0,980719	98,517959	1,412075	0,980836	95,80606	0,717038	0,981707	68,72596	0,638093	0,980851				307,52058	3,403345	0,981228	454,11483	4,888555	0,980263	455,41634	2,689736	0,98222	
Lab 21	96,10607	0,954678	0,999368	96,302992	0,633388	0,999303	94,69722	3,015061	0,999605	68,11234	0,604068	0,999112	288,3962	3,952828	0,999455	289,82719	4,598807	0,999073	424,42447	4,016007	0,999494	426,02197	4,999572	0,999285	
Lab 22	95,09143	2,728212	0,998402	96,032158	4,047505	0,998312	93,21277	7,446187	0,996484	62,97648	3,962387	0,996522	288,14248	9,871714	0,998051	291,51654	8,041493	0,997293	433,67866	12,50977	0,998198	438,68048	2,303907	0,997528	
Lab 23	92,35237	3,330445	0,999829	92,188313	0,596967	0,999667	67,82344	1,210618	0,999273	67,82344	1,210618	0,999273	268,84228	4,127307	0,999803	268,66985	3,698228	0,993731	405,49705	4,24238	0,99952	407,53842	11,45735	0,999389	
Lab 24	90,54473	3,200774	0,987749	90,529189	4,077301	0,986973	91,11802	2,552239	0,989084	67,66498	2,252637	0,98786				266,40482	9,709004	0,987834	387,33583	14,34324	0,98524	390,42818	11,83164	0,99192	
Lab 25	95,95415	4,466521	0,999253	97,381855	4,57889	0,99918	95,35869	3,283128	0,999038	69,58882	3,437032	0,999145	277,65256	13,02805	0,999093	280,65766	13,04856	0,999131	406,04988	19,87697	0,999113	410,64688	18,85983	0,99912	
Lab 26	95,15052	2,59326	0,999291	94,390605	2,652586	0,999155	94,7637	2,66805	0,999315	71,4571	1,651842	0,999266	281,77417	6,74605	0,999484	281,38677	7,906486	0,999273	409,24838	11,31262	0,999228	413,4493	10,37624	0,999313	
Lab 27	95,7624	2,989227	0,995738	95,537864	3,445421	0,995497	94,26934	1,258355	0,996063	69,52822	2,178242	0,996213	272,4276	8,22679	0,996589	274,16693	8,889261	0,995976	395,40612	13,49262	0,994097	402,47135	11,87676	0,997088	
Lab 28																									
Lab 29	95,28013	3,098271	0,990713	97,626955	5,120154	0,991717	93,65408	1,338904	0,991505	70,18108	2,152805	0,992097	278,85763	7,064433	0,991504	282,61741	10,04637	0,991121	415,66425	19,33325	0,991172	409,46395	6,29086	0,992828	
Lab 30	99,22817	1,486594	0,99782				92,75296	2,986384	0,997613	73,29112	0,417308	0,998042	286,52391	5,171609	0,998052	299,81079	4,220133	0,997711	441,73389	8,141481	0,997834	424,23021	3,934461	0,997859	
Lab 32																									
Lab 33							88,02007	6,771762	0,969328																
Lab 34	98,47194	2,298105	0,988147	103,0345	2,606817	0,986313	100,9727	2,013315	0,98846	74,14839	1,559595	0,987727	278,65394	7,002975	0,988143	280,17304	7,781927	0,987913	403,39981	10,38335	0,987249	404,40158	11,08243	0,98773	
Lab 35	94,66292	1,035387	0,996624	94,410222	1,126998	0,996565				70,17521	0,653773	0,996682	284,90193	2,990338	0,996789	287,94207	3,542429	0,996627	422,29322	4,976809	0,996437	420,10334	4,462539	0,997226	
Lab 36	91,00635	0,8221	0,998213	90,62134	1,308987	0,997781	89,41819	2,373128	0,996414	65,35392	1,758941	0,997992				284,11154	4,678937	0,996509	378,21828	7,29247	0,996909	382,64	9,414744	0,997995	
Lab 56	95,49856	0,8847	0,999728	97,090997	1,066576	0,999757	90,07073	8,377518	0,998501	67,37218	1,706219	0,998827	284,77287	1,727691	0,999351	285,51729	8,974194	0,998384	417,2328	4,802607	0,999603	434,85712	4,592674	0,998578	
Lab 59	98,28988	3,62028	0,99433	100,1637	5,724336	0,994848	96,68778	6,4109	0,97066	72,34591	3,276258	0,995354	279,90822	9,600236	0,996254	277,83681	14,02992	0,991402	406,21557	20,16647	0,993139	421,65494	16,84926	0,995957	
Lab 60	89,37291	3,326922	0,986297	90,718914	4,555369	0,985754	91,2858	3,395039	0,987974	68,26083	2,044657	0,986906							371,09159	16,26494	0,984515	373,54323	9,335594	0,990218	
Lab 60 BIS	87,91484	2,818509	0,97854	87,692793	3,472797	0,979061	88,19208	2,447748	0,979445	67,59462	2,075551	0,979524													
Lab 61	102,6641	1,881194	0,992118	97,814342	4,14067	0,992262				74,87807	1,416031	0,992328	287,98102	4,556601	0,992457	282,71873	8,770087	0,991869	422,70818	11,31797	0,990656	433,93928	13,20476	0,993615	

HUBER
COCHRAN
INCORRECT DELIVERED DATA

2.3.3 Validation of average of averages

Average of the averages was calculated using the Excel function $fx=+ MEDIA$ that determines the average value of survivors laboratories averages (that are not discarded by previous tests). Value of average of the averages calculated using Excel is coincident with the value estimated by the electronic platform developed for the interlaboratory comparison.

2.3.4 Validation of maximum value

Maximum value was calculated using the Excel function $fx=MAX$ that determines the maximum data between all the averages of survivors laboratories. Maximum value calculated using Excel is coincident with that estimated by the electronic platform developed for the interlaboratory comparison.

2.3.5 Validation of minimum value

Minimum value was calculated using the Excel function $fx= MIN$ that determines the minimum data between all the averages of survivors laboratories. Minimum value calculated using Excel is coincident with that estimated by the electronic platform developed for the interlaboratory comparison.

2.3.6 Validation of range

The calculation of range is simple and immediate, and it is the difference between the maximum and minimum values that were previously validated. Range calculated using Excel was coincident with that estimated by the electronic platform developed for the interlaboratory comparison.

2.3.7 Validation of median

Median is the value around which the other values are equally distributed and was calculated as follows:

-to sort data in ascending order;

-if the number of data is unequal, the median is the central value;

-if the number of data is equal, the median is estimated by calculating the average of the two central values.

These operations were performed automatically on Excel using the function $f_x=MEDIAN$.

It has been applied to values of survivors laboratories.

Median calculated using Excel was coincident with that estimated by the electronic platform developed for the interlaboratory comparison.

2.3.8 Validation of degrees of freedom

Degrees of freedom are the number of independent data and were calculated as follow:

$$v = n-1$$

(15)

Where n is the sum of the number of laboratories that are not discarded by Cochran and Huber tests. Degrees of freedom calculated using Excel were coincident with those estimated by the electronic platform developed for the interlaboratory comparison.

2.3.9 Validation of interlaboratory standard deviation

The interlaboratory standard deviation was calculated using the formula 16 cited in paragraph 9 of the Manual N179/1 Ed.2001 "Guidelines for validation of analytical methods in chemical laboratories " :

$$S_r = \sqrt{\frac{\sum_{i=1}^n (x_i - \bar{x})^2}{n - 1}}$$

(16)

Where $X_1, X_2, X_3, \dots, X_i, \dots, X_n$ are the averages of survivors laboratories, $n-1$ degrees of freedom and \bar{x} the average of the averages. The value of the standard deviation, calculated by the Excel function $fx=+ DEV.ST$, was coincident with that estimated by the electronic platform developed for the interlaboratory comparison.

2.3.10 Validation of coefficient of variation

The coefficient of variation, as described in paragraph 10 of Manual N.179/1 Ed.2001 "Guidelines for validation of analytical methods in chemical laboratories", allows to compare more directly the accuracy at different levels. It is calculated by performing the ratio between the standard deviation and the average of the averages. It is expressed as a percentage as follow:

$$CV \% = \frac{S_r}{\bar{x}} \cdot 100$$

(17)

The CV % calculated using Excel was coincident with that estimated by the electronic platform developed for the interlaboratory comparison.

2.3.11 Validation of repeatability variance

The repeatability variance was calculated according to the formula 18 of UNI ISO 5725-2 ed.2004 , paragraph 7.4.5 dedicated to the calculation of variances.

$$S_{rj}^2 = \frac{\sum_{i=1}^p (n_{ij} - 1) S_{ij}^2}{\sum_{i=1}^p (n_{ij} - 1)}$$

(18)

Where:

S_{rj}^2 is the variance of repeatability;

S_{ij}^2 is the square standard deviation of each laboratory;

n_{ij} is the number of replicates (in this case 5);

$\sum_{i=1}^p (n_{ij} - 1)$ is the sum of the replicates minus one (adding the number of replicates minus 1, which is 4 (5-1=4), as many times as the number of survivors laboratories eg. 4+4+...+4);

Then the variance of repeatability is the ratio between the sum of the product of the number of replicates minus one for the square standard deviation of each laboratory and the sum of the number of replicates minus one. The variance of repeatability calculated using Excel was coincident with that estimated by the electronic platform developed for the interlaboratory comparison.

2.3.12 Validation of variance interlaboratory

The interlaboratory variance was calculated according to the formula 19 of UNI ISO 5725-2 ed.2004 , paragraph 7.4.5 dedicated to the calculation of variances.

$$S_{Lj}^2 = \frac{S_{dj}^2 - S_{rj}^2}{\bar{n}_j}$$

(19)

But in order to be able to calculate these value, is previously necessary estimate:

- $\sum_{i=1}^p (n_{ij} - 1)$ is the sum of the replicates minus one. This means adding many times 4 ($(n_{ij} - 1) = 5-1=4$), which is the number of replicates of the interlaboratory comparison minus one, as is the number of laboratories survivors (p) eg . $4+4+\dots+4$.
- \bar{n}_j is calculated using the formula 20:

$$\bar{n}_j = \frac{1}{p-1} \left[\sum_{i=1}^p n_{ij} - \frac{\sum_{i=1}^p n_{ij}^2}{\sum_{i=1}^p n_{ij}} \right] \quad (20)$$

Where:

p is the number of survivors laboratories and \bar{n}_j the number of replicates;

S_{dj}^2 is the variance of the medium which in turn is calculated with the formula 21:

$$S_{dj}^2 = \frac{1}{p-1} \sum_{i=1}^p n_{ij} (\bar{y}_{ij} - \bar{\bar{y}}_j)^2 \quad (21)$$

As above, p is the number of survivors laboratories, n_{ij} is the number of replicates, marked \bar{y}_{ij} is the average of each laboratory and double marked $\bar{\bar{y}}_j$ is the average of the averages.

At this point it is possible calculate the interlaboratory variance applying the formula n.22 see above:

$$S_{Lj}^2 = \frac{S_{dj}^2 - S_{rj}^2}{\bar{n}_j} \quad (22)$$

Where:

S_{Lj}^2 is the interlaboratory variance;

S_{dj}^2 is the variance of the averages, calculated above;

S_{rj}^2 is the variance of repeatability, calculated in the previous paragraph;

\bar{n}_j as calculated above.

The interlaboratory variance calculated using Excel for each signal was coincident with that estimated by the electronic platform developed for the interlaboratory comparison.

2.3.13 Validation of variance of reproducibility

The variance of reproducibility was calculated according to the formula 23 of the UNI ISO 5725-2:2004, paragraph 7.4.5 dedicated to the calculation of variances.

$$S_{Rj}^2 = S_{rj}^2 + S_{Lj}^2 \quad (23)$$

Where:

S_{Lj}^2 is the interlaboratory variance;

S_{rj}^2 is the repeatability variance;

The variance of reproducibility calculated using Excel for each signal was coincident with that estimated by the electronic platform developed for the interlaboratory comparison.

2.3.14 Validation of lower confidence limit

The lower confidence limit was calculated as specified in paragraph 10.2 of the Manual N179/1 Ed.2001 "Guidelines for validation of analytical methods in chemical" with the following formula:

$$\bar{x}_{\min} = \bar{x} + t_{p=\alpha/2}(S_r/\sqrt{n}) \quad (24)$$

Where:

\bar{x} is the average of averages;

$t_{p=\alpha/2}$ is tabulated value (Table 15 " Values of the Student variable with v degrees of freedom and for levels of probability, p , for each value of v " Manual179/1 Ed.2001) which expresses the Student's T corresponding to 0.050 level of probability and to the number of laboratories;

S_r is the standard deviation (square root) of the variance of reproducibility;

n is the number of survived laboratories.

Table 15. Student's T for lower confidence limit calculation

v	p = $\alpha/2$			p = 1 - $\alpha/2$			p = 1 - α		
	$t_{p=0,005}$	$t_{p=0,01}$	$t_{p=0,050}$	$t_{p=0,950}$	$t_{p=0,975}$	$t_{p=0,995}$	$t_{p=0,90}$	$t_{p=0,95}$	$t_{p=0,99}$
1	-63,66	-12,71	-6,31	+6,31	+12,71	+63,66	6,31	12,71	63,66
2	-9,92	-4,30	-2,92	+2,92	+4,30	+9,92	2,92	4,30	9,92
3	-5,84	-3,18	-2,35	+2,35	+3,18	+5,84	2,35	3,18	5,84
4	-4,60	-2,78	-2,13	+2,13	+2,78	+4,60	2,13	2,78	4,60
5	-4,03	-2,57	-2,02	+2,02	+2,57	+4,03	2,02	2,57	4,03
6	-3,71	-2,45	-1,94	+1,94	+2,45	+3,71	1,94	2,45	3,71
7	-3,50	-2,36	-1,89	+1,89	+2,36	+3,50	1,89	2,36	3,50
8	-3,36	-2,31	-1,86	+1,86	+2,31	+3,36	1,86	2,31	3,36
9	-3,25	-2,26	-1,83	+1,83	+2,26	+3,25	1,83	2,26	3,25
10	-3,17	-2,23	-1,81	+1,81	+2,23	+3,17	1,81	2,23	3,17
11	-3,11	-2,20	-1,80	+1,80	+2,20	+3,11	1,80	2,20	3,11
12	-3,05	-2,18	-1,78	+1,78	+2,18	+3,05	1,78	2,18	3,05
13	-3,01	-2,16	-1,77	+1,77	+2,16	+3,01	1,77	2,16	3,01
14	-2,98	-2,14	-1,76	+1,76	+2,14	+2,98	1,76	2,14	2,98
15	-2,95	-2,13	-1,75	+1,75	+2,13	+2,95	1,75	2,13	2,95
16	-2,92	-2,12	-1,75	+1,75	+2,12	+2,92	1,75	2,12	2,92
17	-2,90	-2,11	-1,74	+1,74	+2,11	+2,90	1,74	2,11	2,90
18	-2,88	-2,10	-1,73	+1,73	+2,10	+2,88	1,73	2,10	2,88
19	-2,86	-2,09	-1,73	+1,73	+2,09	+2,86	1,73	2,09	2,86
20	-2,85	-2,09	-1,72	+1,72	+2,09	+2,85	1,72	2,09	2,85
25	-2,79	-2,06	-1,71	+1,71	+2,06	+2,79	1,71	2,06	2,79
30	-2,75	-2,04	-1,70	+1,70	+2,04	+2,75	1,70	2,04	2,75
35	-2,72	-2,03	-1,70	+1,70	+2,03	+2,72	1,70	2,03	2,72
40	-2,70	-2,02	-1,68	+1,68	+2,02	+2,70	1,68	2,02	2,70
45	-2,69	-2,01	-1,68	+1,68	+2,01	+2,69	1,68	2,01	2,69
50	-2,68	-2,01	-1,68	+1,68	+2,01	+2,68	1,68	2,01	2,68
100	-2,63	-1,98	-1,66	+1,66	+1,98	+2,63	1,66	1,98	2,63
∞	-2,58	-1,96	-1,64	+1,64	+1,96	+2,58	1,64	1,96	2,58

The lower confidence limits calculated using Excel for each signal was coincident with those estimated by the electronic platform developed for the interlaboratory comparison.

2.3.15 Validation of upper confidence limit

The upper confidence limit was calculated as specified in paragraph 10.2 of the Manual N179/1:2001 "Guidelines for validation of analytical methods in chemical" with the following formula:

$$\bar{x}_{\max} = \bar{x} + t_{p=1-\alpha/2}(S_r/\sqrt{n})$$

(25)

Where:

\bar{x} is the average of averages;

$t_{p=1-\alpha/2}$ is tabulated value, from table 16 " Values of the Student variable with v degrees of freedom and for some levels of probability, p , for each value of v " Manual N179/1 Ed.2001, which expresses the Student's T corresponding to 0.950 level of probability and to the number of laboratories;

S_r is the standard deviation (square root of the variance) of the variance of reproducibility;

n is the number of survived laboratories.

Table 16. Student's T for upper confidence limit calculation

v	p = $\alpha / 2$			p = 1 - $\alpha / 2$			p = 1 - α		
	t _{p=0,005}	t _{p=0,01}	t _{p=0,050}	t _{p=0,950}	t _{p=0,975}	t _{p=0,995}	t _{p=0,90}	t _{p=0,95}	t _{p=0,99}
1	-63,66	-12,71	-6,31	+6,31	+12,71	+63,66	6,31	12,71	63,66
2	-9,92	-4,30	-2,92	+2,92	+4,30	+9,92	2,92	4,30	9,92
3	-5,84	-3,18	-2,35	+2,35	+3,18	+5,84	2,35	3,18	5,84
4	-4,80	-2,78	-2,13	+2,13	+2,78	+4,60	2,13	2,78	4,60
5	-4,03	-2,57	-2,02	+2,02	+2,57	+4,03	2,02	2,57	4,03
6	-3,71	-2,45	-1,94	+1,94	+2,45	+3,71	1,94	2,45	3,71
7	-3,50	-2,36	-1,89	+1,89	+2,36	+3,50	1,89	2,36	3,50
8	-3,36	-2,31	-1,86	+1,86	+2,31	+3,36	1,86	2,31	3,36
9	-3,25	-2,26	-1,83	+1,83	+2,26	+3,25	1,83	2,26	3,25
10	-3,17	-2,23	-1,81	+1,81	+2,23	+3,17	1,81	2,23	3,17
11	-3,11	-2,20	-1,80	+1,80	+2,20	+3,11	1,80	2,20	3,11
12	-3,05	-2,18	-1,78	+1,78	+2,18	+3,05	1,78	2,18	3,05
13	-3,01	-2,16	-1,77	+1,77	+2,16	+3,01	1,77	2,16	3,01
14	-2,98	-2,14	-1,76	+1,76	+2,14	+2,98	1,76	2,14	2,98
15	-2,95	-2,13	-1,75	+1,75	+2,13	+2,95	1,75	2,13	2,95
16	-2,92	-2,12	-1,75	+1,75	+2,12	+2,92	1,75	2,12	2,92
17	-2,90	-2,11	-1,74	+1,74	+2,11	+2,90	1,74	2,11	2,90
18	-2,88	-2,10	-1,73	+1,73	+2,10	+2,88	1,73	2,10	2,88
19	-2,86	-2,09	-1,73	+1,73	+2,09	+2,86	1,73	2,09	2,86
20	-2,85	-2,09	-1,72	+1,72	+2,09	+2,85	1,72	2,09	2,85
25	-2,79	-2,06	-1,71	+1,71	+2,06	+2,79	1,71	2,06	2,79
30	-2,75	-2,04	-1,70	+1,70	+2,04	+2,75	1,70	2,04	2,75
35	-2,72	-2,03	-1,70	+1,70	+2,03	+2,72	1,70	2,03	2,72
40	-2,70	-2,02	-1,68	+1,68	+2,02	+2,70	1,68	2,02	2,70
45	-2,69	-2,01	-1,68	+1,68	+2,01	+2,69	1,68	2,01	2,69
50	-2,68	-2,01	-1,68	+1,68	+2,01	+2,68	1,68	2,01	2,68
100	-2,63	-1,98	-1,66	+1,66	+1,98	+2,63	1,66	1,98	2,63
∞	-2,58	-1,96	-1,64	+1,64	+1,96	+2,58	1,64	1,96	2,58

Upper confidence limits calculated using Excel for each signal were coincident with those estimated by the electronic platform developed for the interlaboratory comparison.

2.3.16 Validation of confidence range

It expresses the interval in which the expected value should fall in a normal or Gaussian distribution. It was calculated by subtracting to the upper confidence limit, the lower. The range of confidence calculated using Excel for each signal was coincident with that estimated by the electronic platform developed for the interlaboratory comparison.

2.3.17 Validation of reproducibility limit

This parameter is called "limit of repeatability interval" in paragraph 11 of the Manual N179/1 Ed.2001 and is calculated using the formula 26:

$$|x_1 - x_2| \leq \sqrt{2 S_r} t \quad (26)$$

Where:

S_r is the standard deviation (square root) of the variance of reproducibility, which is the reason why we have decided to rename as REPRODUCIBILITY LIMIT ;

t is the tabulated value interpolated between 25-30 ν obtained from the table 17.

Table 17. Student's T for reproducibility limit calculation

ν	$p = \alpha/2$			$p = 1-\alpha/2$			$p = 1-\alpha$		
	$t_{p=0,005}$	$t_{p=0,025}$	$t_{p=0,050}$	$t_{p=0,950}$	$t_{p=0,975}$	$t_{p=0,995}$	$ t_{p=0,90} $	$ t_{p=0,95} $	$ t_{p=0,99} $
1	-63,66	-12,71	-6,31	+6,31	+12,71	+63,66	6,31	12,71	63,66
2	-9,92	-4,30	-2,92	+2,92	+4,30	+9,92	2,92	4,30	9,92
3	-5,84	-3,18	-2,35	+2,35	+3,18	+5,84	2,35	3,18	5,84
4	-4,60	-2,78	-2,13	+2,13	+2,78	+4,60	2,13	2,78	4,60
5	-4,03	-2,57	-2,02	+2,02	+2,57	+4,03	2,02	2,57	4,03
6	-3,71	-2,45	-1,94	+1,94	+2,45	+3,71	1,94	2,45	3,71
7	-3,50	-2,36	-1,89	+1,89	+2,36	+3,50	1,89	2,36	3,50
8	-3,36	-2,31	-1,86	+1,86	+2,31	+3,36	1,86	2,31	3,36
9	-3,25	-2,26	-1,83	+1,83	+2,26	+3,25	1,83	2,26	3,25
10	-3,17	-2,23	-1,81	+1,81	+2,23	+3,17	1,81	2,23	3,17
11	-3,11	-2,20	-1,80	+1,80	+2,20	+3,11	1,80	2,20	3,11
12	-3,05	-2,18	-1,78	+1,78	+2,18	+3,05	1,78	2,18	3,05
13	-3,01	-2,16	-1,77	+1,77	+2,16	+3,01	1,77	2,16	3,01
14	-2,98	-2,14	-1,76	+1,76	+2,14	+2,98	1,76	2,14	2,98
15	-2,95	-2,13	-1,75	+1,75	+2,13	+2,95	1,75	2,13	2,95
16	-2,92	-2,12	-1,75	+1,75	+2,12	+2,92	1,75	2,12	2,92
17	-2,90	-2,11	-1,74	+1,74	+2,11	+2,90	1,74	2,11	2,90
18	-2,88	-2,10	-1,73	+1,73	+2,10	+2,88	1,73	2,10	2,88
19	-2,86	-2,09	-1,73	+1,73	+2,09	+2,86	1,73	2,09	2,86
20	-2,85	-2,09	-1,72	+1,72	+2,09	+2,85	1,72	2,09	2,85
25	-2,79	-2,06	-1,71	+1,71	+2,06	+2,79	1,71	2,06	2,79
30	-2,75	-2,04	-1,70	+1,70	+2,04	+2,75	1,70	2,04	2,75
35	-2,72	-2,03	-1,70	+1,70	+2,03	+2,72	1,70	2,03	2,72
40	-2,70	-2,02	-1,68	+1,68	+2,02	+2,70	1,68	2,02	2,70
45	-2,69	-2,01	-1,68	+1,68	+2,01	+2,69	1,68	2,01	2,69
50	-2,68	-2,01	-1,68	+1,68	+2,01	+2,68	1,68	2,01	2,68
100	-2,63	-1,98	-1,66	+1,66	+1,98	+2,63	1,66	1,98	2,63
∞	-2,58	-1,96	-1,64	+1,64	+1,96	+2,58	1,64	1,96	2,58

The reproducibility limit calculated using Excel for each signal was coincident with that estimated by the electronic platform developed for the interlaboratory comparison.

CHAPTER IV

2.4 Wheat

Wheat (*Triticum* spp.) is a cereal grain, originally from the Levant region of the Near East but now cultivated worldwide. Wheat is grown in order to obtain grain, from which getting flour or semolina to be used in the production of bread and pasta.

In fact, this plant was called, by the great swedish naturalist Carlo Linneo, with the latin name *Triticum*, that is similar the grind grain to make flour. *Triticum* belongs to the Gramineae family or Poaceae (class: Monocotyledones, genus: Glumiflorae, tribe: Hordeae), that includes many other plants as corn, barley, rice, rye, commonly known as cereals.

2.4.1 Plant structure

Wheat is an herbaceous annual plant up to 1.2 m in height and it is composed by four fundamental parts: roots, stem, leaves and spike.

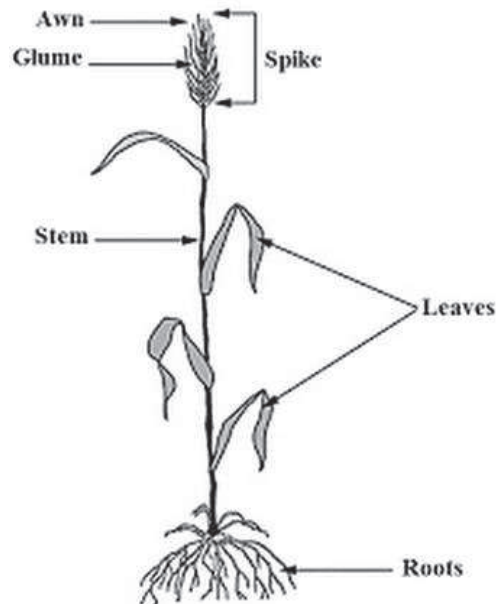

Figure 12. Fundamental parts of wheat plant

The wheat plant has two types of **roots**, primary or seminal roots, present in the embryo in the seed, and secondary or nodal roots. At germination, primary root bursts through the coleorrhizae of the seed, followed by the emergence of four or five lateral seminal roots, which may grow to 2 m in depth and support the plant until the nodal roots appear. Secondary roots are associated with tiller development and are usually first seen when the fourth leaf emerges and tillering starts (Figure 13).

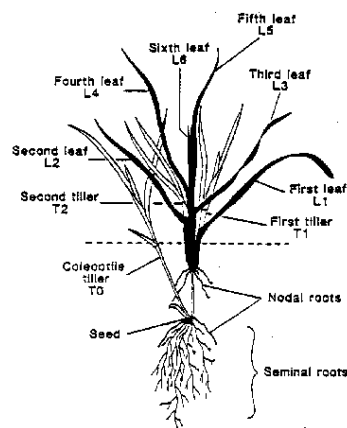

Figure 13. Structure of wheat plant

Compared with the seminal roots, they are thicker and they emerge more or less horizontally; when they first appear they are white and shiny. At maturity, the root system extends to between 1 and 2 m deep or more depending on soil conditions. Most roots occur in the top 30 cm of soil.

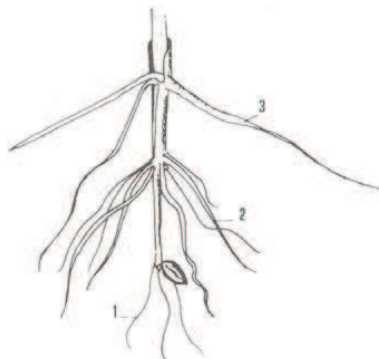

Figure 14. Root system scheme. 1- seminal roots. 2-3 nodal roots

Seminal roots originate from hypocotyl of the embryo and are the roots upon which the young plant depends for the intake of water and nutrients. They do not necessarily end their usefulness to the plant when the permanent roots are formed. Their duration as useful organs, after this time, varies according to conditions. Sometimes primary roots may still be functioning when the plant is mature. On the other hand, many of primary roots may die and disintegrate soon after secondary roots are formed. A cross section of a young primary root shows it to be composed generally of three parts: epidermis, cortex, and stele (Figure 15). *Epidermis* consists of a single layer of elongated thin-walled cells. It is from these epidermal cells that root hairs are developed and it is through the epidermal cells that infection occurs. *Cortex* lies just beneath the epidermis and is composed of four or five layers of large, thin walled cells. Endodermis, the innermost layer of the cortex, consists of a single, continuous layer of closely fitting cells. The outer tangential walls of the endodermal cells are thin, while the radial and inner tangential walls are thickened. The pericycle, the outermost layer of the *stele*, consists of a single layer of radially elongated cells. Walls of the pericycle cells are slightly thickened. All the cells are nearly equal in size, except those opposite the xylem, which are smaller. The xylem strands are seven or eight in number and alternate with the phloem. The protoxylem vessels are strengthened with spiral thickenings, but those formed later toward the center are pitted. The phloem bundles consist of series of three thin-walled cells. The conjunctive tissue of the stele consists of thin-walled irregular parenchyma cells. In the center of the stele is found a large central vessel with a heavy wall.

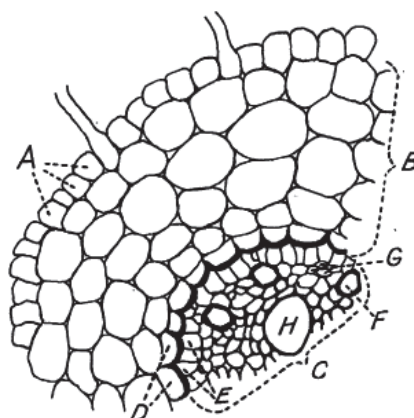

Figure 15. Section of a primary root of a wheat plant. A, Epidermis; B, Cortex; C, Stele; D, Endodermis; E, Pericycle; F, Xylem; G, Phloem consisting of groups of 3 cells; H Central cavity

Secondary roots, which form the bulk of the root system, are formed at or near the crown of the plant. Their number is not limited to a few (usually three), as is true of the primary roots. Nodal roots are formed not only in the original culm of the plant, but also grow from basal nodes of the tiller culms. New secondary roots may be forming for a considerable time during the early growth of the wheat plant. Anatomy of secondary roots does not differ greatly from that of the primary, except that their diameters are greater because of the greater quantity of tissue in the cortex and in the stele (Fellows, 1928).

The **stem** or culm is erect and present structure of cane, in fact it is hollow inside except at the nodes that are solid, because filled with a spongy tissue. Stem grows by stretching the tissues above the nodes. Each culm has 5-8 nodes and it is high 70-100 cm. Stems could proliferate their cells at nodes in order to reinforce the structure, weakened by height and atmospheric agents. Wheat plant has long slender **leaves**, as shown in figure 16, that are composed by four fundamental parts: sheath, leaf blade, ligule and auricle. Sheath grows from each node and wraps up the internode, than it will became a leaf blade. Sheath is tubular at the base, but near to the blade it is split and the margins overlap. In the point of transformation from the sheath to blade, ligule and two auricles are present (similar to membranes). Lamina has a fairly well-marked midrib, along which runs the major vascular bundle of the leaf. It divides the blade into two subequal parts, each of which has a number of parallel lateral ribs or veins, so that the adaxial surface of the blade is corrugated. Leaf blade naturally assumes a twist and is green.

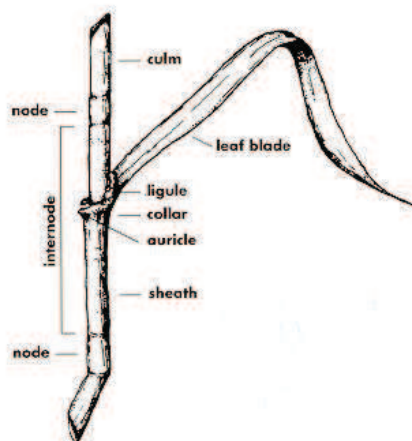

Figure 16. Culm and leaf morphology

Inflorescences are composed of varying numbers of minute flowers, ranging from 20 to 100. Flowers are borne in groups of two to six in structures known as spikelets, which later serve to house the subsequent two or three grains or caryopsis produced by the flowers. So wheat grains are borne on a spike, or ear. The major axis, called rachis, bears two rows of spikelets in alternating order side (Figure 17). Mature spikelet will contain 3-6 fertile flowers, each containing reproductive organs necessary for kernel development. A mature spike may contain about 15-18 spikelets (Kirby, 1974).

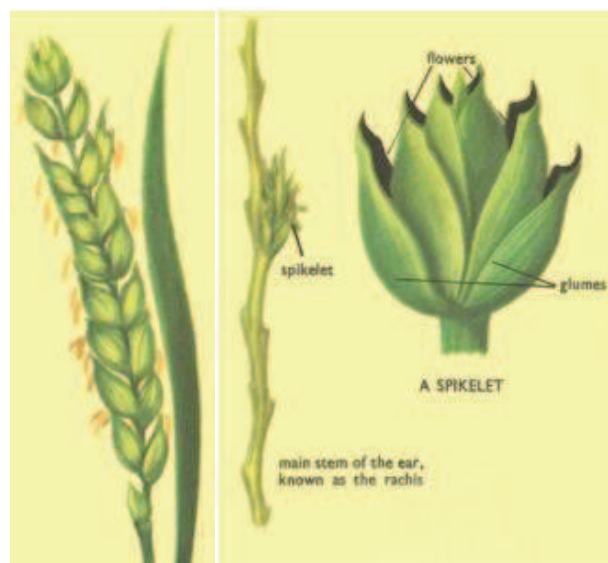

Figure 17. The spike and the spikelet structure

The spikelets are encased by glumes, and they are composed by rachilla (axis on which flowers are inserted). Each flower is hermaphrodite, so it contains both sexual organs (gynaeceum and androecium) and is protected by two glumes (lemma and palea).

In durum wheat and in some spp. of common wheat, there is an extension of lemma called "beard" as shown in figure 18.



Figure 18. Spikes of 1. *Triticum turgidum* ssp. *Durum*, 2. *Triticum aestivum* ssp. *aestivum* bearded (common or bread wheat), 3 *Triticum aestivum* ssp. *aestivum* without beard

Androecium is the male sexual apparatus, and is composed by three stamens (filaments plus anthers that contains pollen). Gynaecium is female apparatus composed by ovary and feathery stigmas. Pollen grain, when settled on a stigma, germinates in about one and one-half hours. Rachilla is the axis of a spikelet, branched alternately, bearing a pair of empty (or nonflowering) glumes at the base, and a series of up to six florets in the spikelet. Each floret consists of a pair of paleas (flowering glumes), the lower or outer lemma and the upper or inner palea, enclosing the ovary and later the caryopsis (Figure 19)

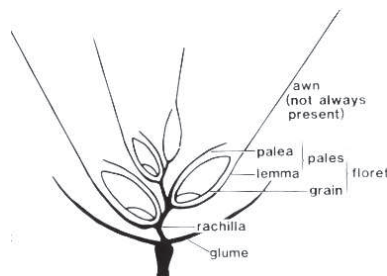

Figure 19. Structure of a spikelet

At the base of the floret next to the lemma, is a pair of lodicules that swell at the time of fertilization, pushing the floret open and allowing the anthers to emerge on elongated filaments. Floret size decreases from the base upward, and the largest grains are usually in the basal or second florets. Spikelet differentiation starts in the middle of the spike and proceeds toward the base and the tip. Within the floret, differentiation proceeds from the outside inward (Bonnet, 1966).

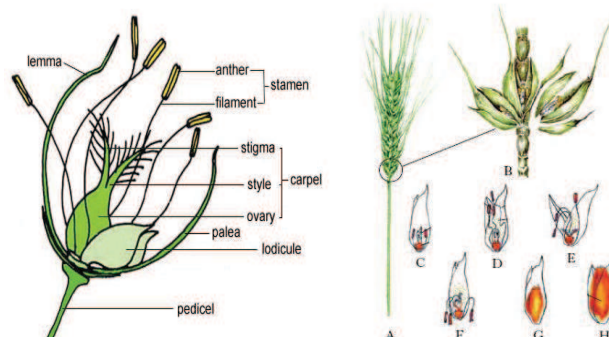

Figure 20. Each flower of the spike (C) originates a fruit called caryopsis (H). Flowers and than caryopsis (during maturity) are gathered in small groups to form an agglomerate called spikelet (B). The whole inflorescence is a spike (A).

Figure 21 show the life cycle of the plant from seeding, germination, growth of roots and culm, to the maturity of the caryopsis on the spike. Wheat grows under a wide range of climates and soils, but is best adapted to temperate regions with rainfall between 30 and 90 cm.

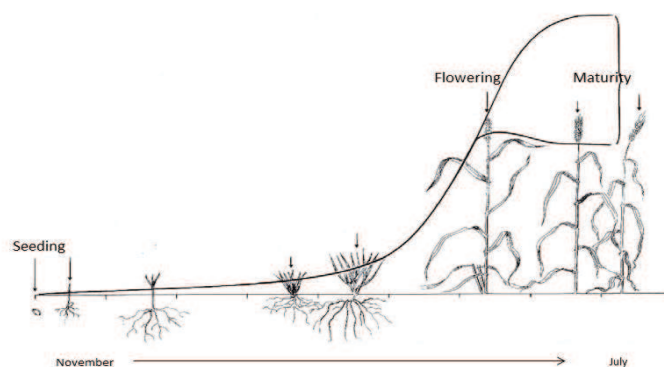

Figure 21. Life cycle of wheat plant

2.4.2 Caryopsis structure and composition

In the ovary there is an ovule that, after fecundation by pollen became a seed, and the whole ovary became the fruit. In fact the seed or kernel (caryopsis) is a dry indehiscent fruit. Each fertile flower originates only one fruit which contains one seed. This one is totally plunged in the caryopsis, so is difficult to see observing the seed. Caryopsis

has ovoid shape, more or less stretched with a dorsal and ventral side. Dorsal side (respect to spikelet axis) is smoothly rounded, while the ventral side has a deep crease, called ilo (Figure 22).

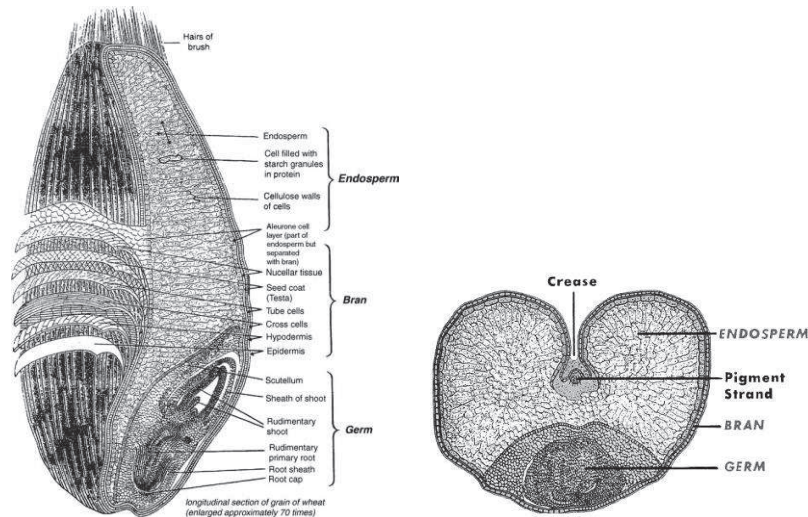

Figure 22. Wheat grain structure and a cross section showing the depth of the crease

On the base of the dorsal side there is the germ (2-3%). The germ or embryo, kernel's reproduction system, is situated at the point of attachment of the spikelet axis, and the distal end has a brush of fine hairs. The embryo is made up of scutellum, plumule (shoot) and the radicle (primary root) and consists mainly of proteins, oil, enzymes and B group vitamins. Scutellum is the region that secretes some of the enzymes involved in germination and absorbs the soluble sugars from the breakdown of starch in the endosperm. Surrounding the endosperm is a metabolically active layer of cells or the aleurone layer, the testa or seed coat and the pericarp or fruit coat. (Kirby, 2002). The endosperm is the main part of the caryopsis (80-90%) made mainly by starch, that will be used by embryo during germination, and protein as gluten. Bran (pericarp) is the outer layer protecting the grain (14-17%).

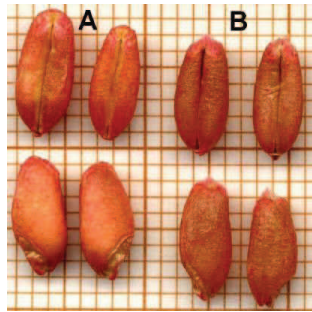

Figure 23. Caryopsis of *Triticum durum* (A) and *Triticum aestivum* (B)

Endosperm could have mealy texture, such as in bread wheat (*Triticum aestivum*, B in figure 23.), or vitreous texture such as in durum wheat (A in figure 23). The average weight of a single caryopsis of durum wheat is about 30-55 mg, instead in bread wheat is more or less 30-40 mg. The average composition of caryopsis is: starch 60-70%, protein 20%, simple sugars 2.5-4% , fiber 2-2.5%, fat 1.5-2%, ashes 1.5-2.2%. Humidity should not exceed 12-13% in order to have a good shelf life. Proteins of kernel are classified according to their solubility: a) albumin water-soluble; b) globulin in neutral salt solution; c) prolamin (gliadin) in alcoholic solutions; d) glutenin in acid or basic solutions. Albumin and globulin are enzymatic proteins localized mostly in the embryo, they are rich in essential amino acids that are important for a good diet. Gliadin and glutenin instead are storage proteins, localized in the endosperm, globally they represent the gluten, from which depend technological quality of flour (Baldoni and Giardini, 2000). Table 18 shows the comparison between durum and common wheat about morphological and weather conditions.

Table 18. Morphological and climate characteristics of wheat

Elements	<i>Triticum Turgidum</i> (durum wheat)	<i>Triticum Aestivum</i> (common wheat)
Culm:		
Last internodes	full	hollow
Height (cm)	80-130	70-120
Resistance	frail	elastic and resistant
Inflorescens:		
Type	spike	spike
Bearded	With beard	With and without beard
Caryopsis:		
Texture	vitreous	mealy
Color	shaded	white or reddish
Cold climate-	less resistant	more resistant

2.4.3 Production of wheat

Wheat is one of the most important agricultural resources in the world and it plays a multifunctional role, because it involves bread and pasta production chains, that represent traditional Italian food in the worldwide (Beleggia et al., 2011).

Globally, wheat is the leading source of vegetable protein in human food, having a higher protein content than other major cereals, maize (corn), or rice. In accordance with the International Grains Council (Table 19), the entire wheat production for 2013 is about 700 million tons, instead the Italian production is 7.5 million of tons as declared by Food and Agriculture Organization.

Table 19. Total wheat in million tons

WHEAT	2013/2014	2014/2015	2015/2016	2016/2017	
Production	717	730	736	722	729
Trade	157	153	158	154	156
Consumption	699	717	719	717	720
Carryover stocks	188	201	217	223	226

In the national contest, Apulia is the first producer among Italian regions with 22% of durum wheat production. This primacy allows to Apulia to be involved in process, product and management innovations (Chinnici, 2008, Sacco et al., 1998). Grain is harvested once a year, but it is consumed year-round. Normally it is stored in bins until being used. Under normal storage conditions wheat could retain its grain quality after years of storage, while the processed wheat ingredients can maintain their baking quality for months. Factors such as humidity, temperature and initial moisture content of stored products directly affect shelf life of wheat grains and processed wheat ingredients. Poor storage conditions or high moisture content could lead to heat damaged grain and/or moldy wheat, which render them unsuitable for human consumption (Fao, 2015)

2.4.4 *Wheat flour milling*

Milling is the most common processing technique for wheat grains for human consumption. Roller mill is the primary technology used for milling wheat into flour. The technology is a gradual reduction system so that damage to the components of wheat is minimized during flour milling. The main goal of milling is to separate the bran and germ from the starchy endosperm so that the endosperm can be ground into flour. A modern flour milling system is divided into three parts based on their functions: breaking, reduction, and sifting. The break system consists of a number of pairs of corrugated rolls that break wheat kernels and separate subsequently the endosperm from bran and germ. The reduction system is made of a number of pairs of smooth rolls that reduce the endosperm into fine particles. The sifting system contains sieves with different screen and cloth meshes separating flours based on particle size. In an industrial mill a wheat kernel is separated into more than thirty different parts called flour streams, each having its own

unique characteristics. At the end of the process, the various streams are blended and mixed to make various grades of flour. Flour extraction defined as the proportion of flour by weight milled from a known quantity of wheat is commonly used in the milling industry to define different types of wheat flour. When the rate of extraction is 75% or less, typical white flour is generated. If the extraction rate exceeds 80%, the flour will contain significant amount of nonendosperm particles, and if the flour extraction approaches 100%, whole meal flour is produced. Pearling or debranning is a pretreatment process prior to roller milling of wheat and has recently gained interest of flour millers. Wheat grains are physiologically composed of 84% endosperm, 13.5% bran, and 2.5% germ. However, commercial roller mills are rarely able to extract all the endosperm into flour without bran contamination in part because of their limited ability to separate the endosperm from the bran. The actual extraction rates are normally less than 78% by weight depending on several factors as wheat class, cultivar, and milling equipment. Thus, the debranning or pearling process was developed to remove bran prior to milling to improve flour extraction and prevent bran contamination of refined flour products.(Lin, 2008)

CHAPTER V

2.5 Durum wheat fingerprinting

In this study we report the use of NMR spectroscopy on Apulian organic durum wheat and flour, in order to understand from the metabolic composition what are the discriminants to identify cultivars and batch of belonging. The NMR spectra, used as fingerprints, were analyzed by multivariate statistical technique. The approach used in this work shows the high potential of fingerprinting to increase the value of Apulian wheat. In order to improve the quality of production, and to certify origin and typicality of wheat and flour, it is possible identify, quantitatively and qualitatively, all metabolites by metabolic approach defining a "fingerprint". In fact nuclear magnetic resonance (NMR) spectroscopy, followed by chemometric analysis (Winnig et al., 2008) identify and classify food productions in terms of genetic and geographical origin, agronomic practices and technologies used during production. The accuracy of NMR spectra is similar for all compounds, and that is enormously helping statistical analysis. The spectrum is therefore used as a fingerprint of wheat without any need to correlate the signal to the molecule structure (Lamanna et al., 2011). Thus this approach allows to estimate wheat and flour metabolites and to understand how genetic, technological and environmental factors could modify them (Graham et al., 2009, Krishnan et al., 2004). Moreover it is able to discriminate wheat samples from flour samples, to individuate cultivar and batch with a reliability of 95%. It is possible also understand which is the relative batch of belonging from a flour sample.

2.5.1 Materials and methods

Kernels of durum wheat were derived from two different organic farms of Altamura (Apulia region, Southern Italy-Figure 24) and samples were harvested in the year 2013.

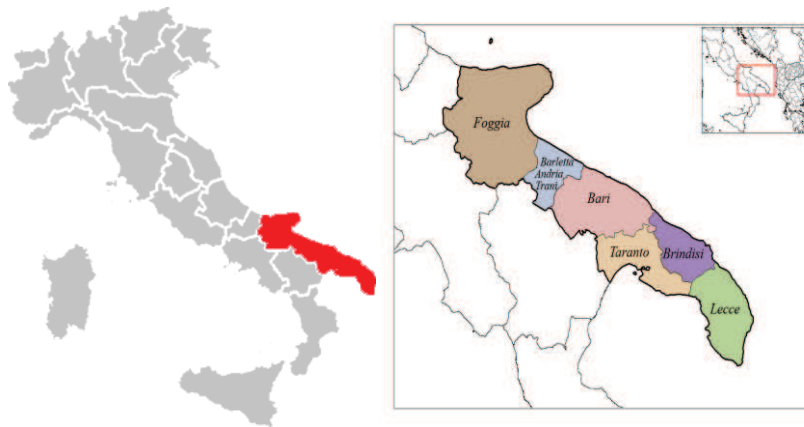

Figure 24. Italy and Apulia region

The farm number 1 owned three growing areas called as A, B and C. Areas A and B (30 ha in total) were cultivated to Simeto cultivar, instead area C (7 ha) was cultivated to Pietrafitta cultivar. The farm number 2 represent only one area called D (4 ha) that was cultivated to Simeto cultivar. So areas interested by samplings are in total 4. To obtain a representative set of grain, several sampling points were identified according to the Decree of Ministry of Agricultural, Food and Forestry Policies “Disposition to identify minimum requirements for sampling procedures of organic products”. Samplings points shall be proportional to the surface of the field, and they were calculated observing table 20.

Table 20. Calculation of the minimum number of sampling points

Surface (mq)	Minimum number of sampling points
< 2000 mq	1
2001-5000 mq	3
5001-10000 mq	5
for each 5000 mq in addition	1 in addition

A major number of samples was taken, overcoming minimum values of the decreed: 80 samples were taken from areas A and B, 40 samples for C and 60 samples for D, as shown in table 21.

Table 21. Summary table

Farm	Samplings area	Surface sampling areas (Ha)	Cultivar	Number of sampling points
1	A	30	Simeto	80
1	B			
1	C	7	Pietrafitta	40
2	D	4	Simeto	60

From each of wheat samples, a portion of grains was taken in order to produce refined flour grinding them through NAMAD mill. Germ, bran and rough flour were produced from milled kernels. Rough flour was milled again to produce refined flour.

Extraction procedure: each sample was weighed (0,9 g) in vial of 20 mL. Than 4,0 mL of Oxalate buffer at pH=4.0 [this pH value was reached after addition of 37% HCl to 100 mL of an aqueous solution containing $\text{Na}_2\text{C}_2\text{O}_4$ (0.25 M) and NaN_3 (2.5×10^{-3} M)] were added to the sample. Samples were put in an ultrasonic bath at 60° C for 1 hour. The temperature was controlled and stabilized by Vertex. After, they were centrifuged at 4000 rpm for 20 minutes. Than 900 μL of supernatant were taken, poured in an Eppendorf® of 1.5 mL containing 100 μL of TSP (0.15%w sodium salt of trimethylsilyl propionic-2,2,3,3-d4 acid in D_2O) as internal standard and centrifuged at 3000 rpm for 20 minutes. This procedure guarantee homogeneity, repeatability and reproducibility of samples. Solutions were poured in NMR tubes for the analysis.

^1H NMR Analysis: one-dimensional ^1H NOESY (Nuclear Overhauser Effect Spectroscopy) spectra were recorded on a Bruker Avance I 400 MHz spectrometer equipped with a 5 mm inverse probe and with an autosampler. Spectra were acquired with 128 scans of 64 K data points with a spectral width of 8013 Hz, a pulse angle of 90°, an acquisition time of 4.09 s, a mixing time of 10 ms and a recycle delay of 3.0 s. Each spectrum was acquired using TOPSPIN 3.0 (Bruker BioSpin GmbH, Rheinstetten, Germany) under an automated procedure lasting approximately 22 min and consisting of: sample loading, temperature stabilization for 5 min, tuning, matching, shimming and 90° pulse calibration. Free induction decays (FIDs) were Fourier transformed, the phase was manually corrected, the baseline was automatically corrected and the spectra were aligned to TSP singlet, fixed at 0 ppm (Gallo et al, 2014).

Statistical Analysis: Statistical elaboration of the NMR data was performed using AMIX (Bruker BioSpin GmbH, Rheinstetten, Germany). NMR spectra were subdivided in small regions called buckets of regular width of 0.05 ppm. In order to find “natural” grouping of data, bucket tables were subjected to principal component analysis (PCA), a multivariate unsupervised statistical method that reduces the dimensionality of data to a subspace consisting in a few principal components (PCs) which are related to directions of largest amount of the variance in the spectra matrix.

2.5.2 Results and discussion

Primary metabolites contained in wheat and flour were characterized by processing all spectra with the same procedures. In table 22 are shown the major and the most representative compounds of wheat and flour in relation with the relative group, multiplicity and chemical shift.

Table 22. Some compounds contained in aqueous extracts of wheat and flour

Compound	Group	Multiplicity	δ 1H
Leucine	δ -CH ₃	d	0.96
Valine	γ -CH ₃	d	0.96
Isoleucine	δ -CH ₃	t	0.93
Alanine	β -CH ₃	d	1.47
Arginine	β -CH ₂	m	1.89
	γ -XH ₂	m	1.68
Maltose	CH ₃	d	5.23
	CH ₃	d	5.40
Glycine-betaine	N-CH ₃	s	3.27
	α -CH ₂	s	3.91
Fructose	CH	m	4.00
Saccharose	CH-1	d	5.42
α -glucose	CH-1	d	5.24
β -glucose	C ₁ H	d	4.63
	C ₂ H	d	3.23
Formic acid	HCOOH	s	8.46

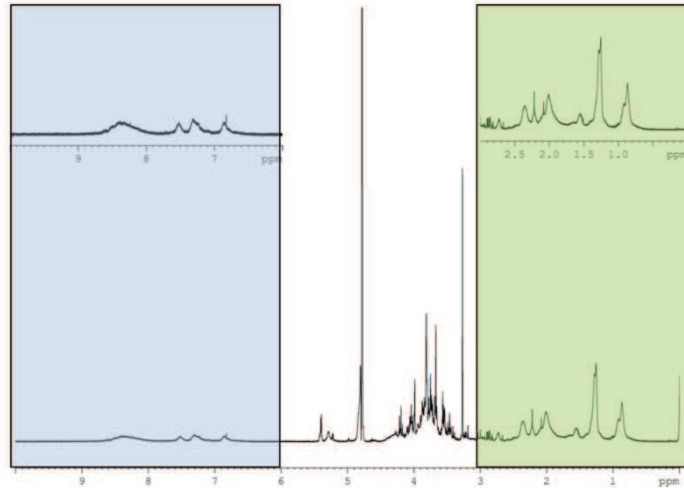

Figure 25. Typical 1D ^1H NMR spectrum of wheat sample

All samples of wheat and flour were considered for analysis and the bucket table was realized on the entire spectrum. PCA was performed on data and the scores plot shows as samples were grouped in 4 cluster depending on samplings area. Moreover a clear subdivision was observed between samples of wheat that were distributed in the first and fourth quadrant and samples of flour in the second and third quadrant. (Figure 26)

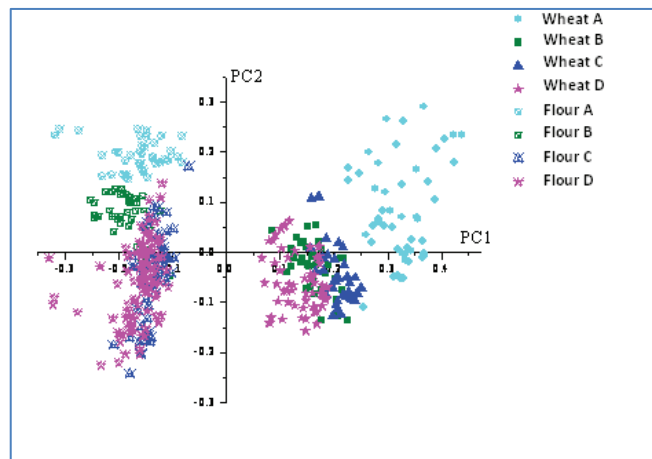

Figure 26. Wheat and flour, entire spectrum, bucket of 0.05 ppm

Then, data obtained from wheat and flour sample were processed separately realizing bucket table in the same condition, considering each time a different region of amino acid 0.5-3 ppm (Figure 27-28), carbohydrates 3-6 ppm (Figure 29-30), and aromatic compounds 6-10 ppm (Figure 31-32).

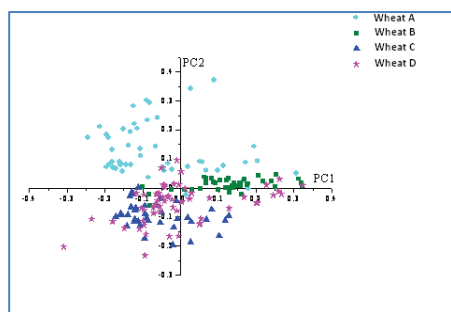

Figure 27. Wheat, amino acid region, bucket of 0.05 ppm

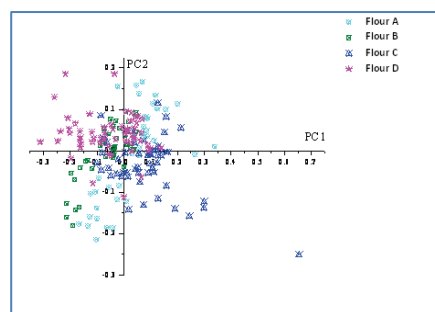

Figure 28. Flour, amino acid region, bucket of 0.05 ppm

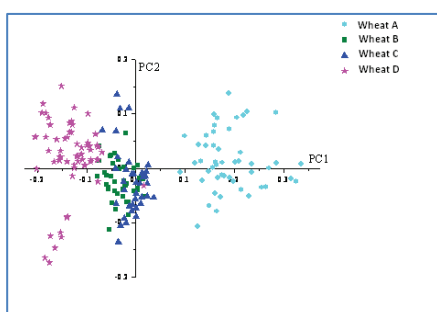

Figure 29. Wheat, carbohydrates region, bucket of 0.05 ppm

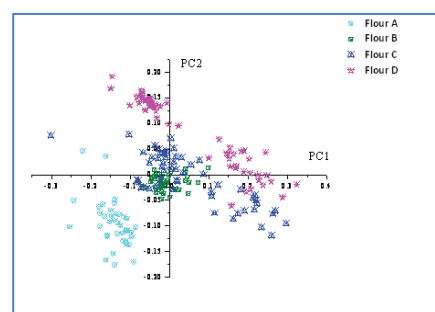

Figure 30. Flour, carbohydrates region, bucket of 0.05 ppm

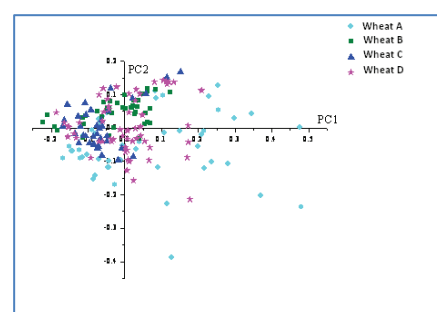

Figure 31. Wheat, aromatic region, bucket of 0.05 ppm

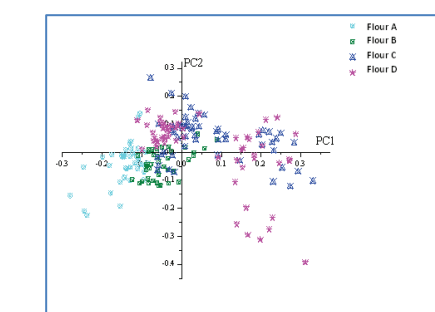

Figure 32. Flour, aromatic region, bucket of 0.05 ppm

Score plots shown as the content of amino acid and aromatic compounds is similar in wheat and flour instead the greatest contribution for the discrimination of the samples is

represented by the amount of carbohydrate in the matrix. In fact (Figure 29-30) the wheat sample A is distributed among the first and the fourth quadrant, instead the flour sample A is concentrated in the third quadrant. The wheat sample C is distributed between the second and third quadrant, instead the flour sample C between the second and the fourth quadrant. The wheat sample D is spread among the second and the third quadrant, the flour sample D among the first and the second. This analytical procedure has been validated as internal test method, used as a protocol during the first international interlaboratory comparison.

CHAPTER VI

2.6 The first international ILC- Validation of a 1D ¹H-NOESY experiment for fingerprinting of wheat and flour

Since its first application as quantitative technique (Jungnickel and Forbes, 1963), NMR spectroscopy has been successfully used for many applications involving several kind of matrixes (small molecules, pharmaceuticals and natural products in both simple and complex mixtures). One of the major advantages of quantitative NMR (qNMR) is its primary analytical characteristic. It can be applied in the estimation of purity of compounds without using any specific reference standard. Moreover, recent progress in the development of high sensitive instruments allowed for reduction of the detection limits, thus making the technique appealing for analysis of molecules in very low concentrations. A comprehensive recent review aiming to extend awareness of experimental protocols for accurate NMR quantification of analytes is available in "Trends in Analytical Chemistry" (Bharti and Roy, 2012).

Despite the advantages deriving from the use of qNMR and despite the plethora of well documented validation processes (e.g., precision, accuracy, linearity, reproducibility, robustness, selectivity, and specificity), very few official NMR based quantification methods are known. With the aim to extend the use of qNMR in official methods, Innovative Solutions organizes NMR interlaboratory comparisons (ILCs) according to ISO/IEC 17043:2010 (Gallo et al., 2013) and reference normative therein. ILCs provide objective standards for individual laboratories, permit them to compare analytical results from different laboratories and represent a way to check the quality and the accuracy of the analytical job. Validation by ILCs is the starting point for official recognition of the analytical methods. The aim of this interlaboratory comparison was the validation of a fingerprinting NMR method for classification of wheat and flours.

2.6.1 The scheme of IS-NMR-ILC

The IS-NMR-ILC scheme was organized according to the following steps:

- a) Call;
- b) Registration;
- c) Publication of the experimental instructions for participants;

- d) Sample preparation;
- e) Sample delivery;
- f) NMR analysis;
- g) Submission of results;
- h) Data elaboration;
- i) Report publication.

In the following, the currently operative scheme (Edition: September 2014; Version no. 1) is reported in *italic* characters. In addition, in normal characters, each paragraph contains updates regarding the execution of the present ILC.

Table 23 show us the timetable of each phase of this ILC

Table 23. ILC timetable

Period n.	Expected period	Actual period	Description
1	2014/09/08 – 2014/10/31	2014/09/08 – 2014/10/31	Call open and registration
2	2014/11/01 – 2015/01/15	2014/11/01 – 2015/03/08	Recognition of the spectrometers available for the ILC and publication of the “Instructions and contract terms”, sample preparation, homogeneity and stability control
3	2015/01/16 – 2015/01/31	2015/03/09 – 2015/03/27	Sample delivery
4	2015/02/01 – 2015/02/28	2015/03/28 – 2015/05/17	NMR experiment registration and data submission
5	2015/03/01 – 2015/04/30	2015/05/18 – 2015/07/31	Data elaboration and report preparation

Period 2 was delayed due to technical problems on NMR spectrometer during homogeneity tests. During period 3 one participant received one non-compliant NMR tube and another participant did not received the samples at all. Both participant received new NMR tubes during a second delivery step. The confirmation of the delivery was given by email from participants. Period 4 was delayed due to motivated delays claimed by some participants and due to some errors occurred during data submission of some other participants. Such errors derived from failure to comply with instructions by those participants. Even though the recovery of correct data was time-consuming, the coordinators decided to give additional time for proper corrections.

a. Call

The call makes known the aim of the ILC, the scientific committee, the sample matrix and the NMR experiment selected for the ILC. Technical requirements of the participants are also indicated.

The call of the present ILC was published on 2014/09/08 and the dead line of the registration was on 2014/10/31.

b. Registration

In order to participate to IS-NMR-ILC, a NMR Spectrometer Profile must be active. Each participant will confidentially be provided with a unique identification username and password to login the NMR spectrometer profile. If a participant plans to use more than one NMR spectrometer, additional NMR Spectrometer Profiles must be activated. Each participant must send one registration form per NMR spectrometer:

Activation of NMR Spectrometer Profile does not give any right to participate to interlaboratory comparisons.

Interlaboratory comparison:

After registration acceptance, a link to the specific ILC will be active on the NMR Spectrometer Profile.

For the present ILC, registration was free and the minimum number of participants allowed was 10. After deadline, the number of registered participants was 37 for a total of 46 spectrometers.

c. Publication of the experimental instructions for participants

General information and experimental instructions will be published on the NMR spectrometer profile. Instructions will be available only after registration is completed.

Participants received the following instructions to acquire spectra under manual or automatic procedures:

- sample loading;

- temperature stabilization at 298.0 ± 0.1 K for at least 5 min;
- lock on solvent signal [CD_3OD for tube A; $\text{H}_2\text{O}/\text{D}_2\text{O}$ (90/10) for tubes B-E];
- tuning and matching;
- shimming;
- 90° hard pulse calibration (for 1D ^1H -NOESY experiments, selective pulse for pre-saturation step was calculated taking into account the solvent signal width of 25 Hz);
- receiver gain optimization (automatic);
- spectrum acquisition.

Step 1: temperature calibration (Findeisen et al., 2007)

Use tube "A" as nuclear magnetic resonance thermometer. On the temperature control unit of your spectrometer, the sample temperature was set to 298 K. Record a routine ^1H spectrum by 90° single excitation pulse sequence was recorded ("s2pul" for Agilent, "zg" for Bruker). The difference $\Delta\delta$ was calculated after peak picking the signals at ca. 4.8 and 3.3 ppm. $\Delta\delta$ was used for calculation of the sample temperature T [K] according to the following equation:

$$T = -16.7467 \cdot (\Delta\delta)^2 - 52.5130 \cdot \Delta\delta + 419.1381$$

(27)

Adjust the temperature control unit so to obtain a $\Delta\delta$ value allowing for calculated $T = 298.0 \pm 0.1$ K. Once optimized, use the temperature control unit setup for all of the other measurements described in the following. Do not optimize temperature for each session.

Step 2: Spectra registration (tubes A-E)

For each NMR tube, 5 spectra must be recorded to comply with conditions for intermediate precision, i.e. same NMR tube, same spectrometer, same user, at least 24 h delay between runs, removal of the NMR tube from the magnet from run to run. Thus, schematically, 5 registration sessions are required:

1st session:

n. 1 spectrum for tube "A" [routine ¹H spectrum by single excitation pulse ("s2pul" for Agilent, "zg" for Bruker)]; filename: TUBE LABEL_1;
n.1 spectrum for tube "B" [1D ¹H-NOESY experiment ("NOESY" for Agilent, "noesypr1d" for Bruker)]; filename: TUBE LABEL_1;
n.1 spectrum for tube "C" [1D ¹H-NOESY experiment ("NOESY" for Agilent, "noesypr1d" for Bruker)]; filename: TUBE LABEL_1;
n.1 spectrum for tube "D" [1D ¹H-NOESY experiment ("NOESY" for Agilent, "noesypr1d" for Bruker)]; filename: TUBE LABEL_1;
n.1 spectrum for tube "E" [1D ¹H-NOESY experiment ("NOESY" for Agilent, "noesypr1d" for Bruker)]; filename: TUBE LABEL_1;

2nd session (at least 24 h later the previous session; pulse programs as in the 1st session):

n. 1 spectrum for tube "A" (routine ¹H spectrum by single excitation pulse sequence); filename: TUBE LABEL_2;
n.1 spectrum for tube "B" (1D ¹H-NOESY experiment); filename: TUBE LABEL_2;
n.1 spectrum for tube "C" (1D ¹H-NOESY experiment); filename: TUBE LABEL_2;
n.1 spectrum for tube "D" (1D ¹H-NOESY experiment); filename: TUBE LABEL_2;
n.1 spectrum for tube "E" (1D ¹H-NOESY experiment); filename: TUBE LABEL_2;

3rd session (at least 24 h later the previous session; pulse programs as in the 1st session):

n. 1 spectrum for tube "A" (routine ¹H spectrum by single excitation pulse sequence); filename: TUBE LABEL_3;
n.1 spectrum for tube "B" (1D ¹H-NOESY experiment); filename: TUBE LABEL_3;
n.1 spectrum for tube "C" (1D ¹H-NOESY experiment); filename: TUBE LABEL_3;
n.1 spectrum for tube "D" (1D ¹H-NOESY experiment); filename: TUBE LABEL_3;
n.1 spectrum for tube "E" (1D ¹H-NOESY experiment); filename: TUBE LABEL_3;

4th session (at least 24 h later the previous session; pulse programs as in the 1st session):

n. 1 spectrum for tube "A" (routine ¹H spectrum by single excitation pulse sequence); filename: TUBE LABEL_4;
n.1 spectrum for tube "B" (1D ¹H-NOESY experiment); filename: TUBE LABEL_4;
n.1 spectrum for tube "C" (1D ¹H-NOESY experiment); filename: TUBE LABEL_4;
n.1 spectrum for tube "D" (1D ¹H-NOESY experiment); filename: TUBE LABEL_4;
n.1 spectrum for tube "E" (1D ¹H-NOESY experiment); filename: TUBE LABEL_4;

5th session (at least 24 h later the previous session; pulse programs as in the 1st session):

n. 1 spectrum for tube "A" (routine ¹H spectrum by single excitation pulse sequence); filename: TUBE LABEL_5;
n.1 spectrum for tube "B" (1D ¹H-NOESY experiment); filename: TUBE LABEL_5;
n.1 spectrum for tube "C" (1D ¹H-NOESY experiment); filename: TUBE LABEL_5;
n.1 spectrum for tube "D" (1D ¹H-NOESY experiment); filename: TUBE LABEL_5;
n.1 spectrum for tube "E" (1D ¹H-NOESY experiment); filename: TUBE LABEL_5;
Summarizing, each participant recorded 25 NMR spectra (5 replicates for each of the 5 NMR tubes)

Acquisition parameters for 1D ¹H-NOESY experiments (tubes B-E)

Agilent spectrometers:

- Pulse program: NOESY
- size of fid (np): 128 K;
- spectral width (sw): 20 ppm;
- transmitter offset (tof): ca. 4.70 ppm (set the chemical shift value of the residual water signal);
- 90° hard pulse (pw): optimized by manual or automatic procedures;
- Steady state (ss): 4;
- number of transients (nt): 16;
- mixing time (mixN): 0.01 s;
- recycle delay (d1): 30 s;
- no sspul (sspul='n')
- no ZQ filter (Gzqfil='n')

- no homo spoil during mixing time (gt1=0, gzlv1=0 and gstab=0)
- presaturation during the whole length of d1, centered at the HDO residual signal with a γB_2 power of about 25 Hz (satmode='yn', satdly=d1, satfrq=tof, set satpower in such a way that the output of getpower(satpwr,tn):\$gB2 \$gB2? is about 25)

Bruker spectrometers:

- Pulse program: noesypr1d
- size of fid (TD): 128 K;
- spectral width (SW): 20 ppm;
- transmitter offset: ca. 4.70 ppm (set the chemical shift value of the residual water signal);
- 90° hard pulse (p1): optimized by manual or automatic procedures;
- power level for presaturation (p19): once optimized p1, calculate p19 by command "pulse 25Hz;
- dummy scans (ds): 4;
- number of scans (ns): 16;
- mixing time (d8): 0.01 s;
- recycle delay (d1): 30 s.

Step 3. Processing parameters for 1D ¹H-NOESY experiments (tubes B-E)

Fourier transform the spectra applying exponential multiplication function with a line broadening of 0.1 Hz. Correct phase and baseline.

Tube A: calculate the $\Delta\delta$ for each session as described above (Step 1).

Tubes B-E: set TSP singlet to 0.00 ppm. Integrate signals using the ranges listed below:

Table 24.

Signal label	Integration range(ppm)	
	Left limit	Right limit
TSP	0.50	-0.50
S1	9.50	9.40
S2	7.56	7.48
S3	5.46	5.32
S4	5.28	5.16
S5	4.68	4.60
S6	4.12	4.07
S7	3.33	3.14

For each spectrum, calculate the integral ratios I_{S1}/I_{TSP} , I_{S2}/I_{TSP} , I_{S3}/I_{TSP} , I_{S4}/I_{TSP} , I_{S5}/I_{TSP} , I_{S6}/I_{TSP} and I_{S7}/I_{TSP} . Signals S1-7 were selected with the aim to appreciate the reproducibility limits of very weak signals (S1 and S2), of medium intensity signals (S3 and S6), of a very intense signal (S7) and of signals (S4 and S5) with the chemical shift in close proximity to pre-saturation frequency (ca. 4.70 ppm). In figure 33 a typical 1D ^1H -NOESY spectrum is shown.

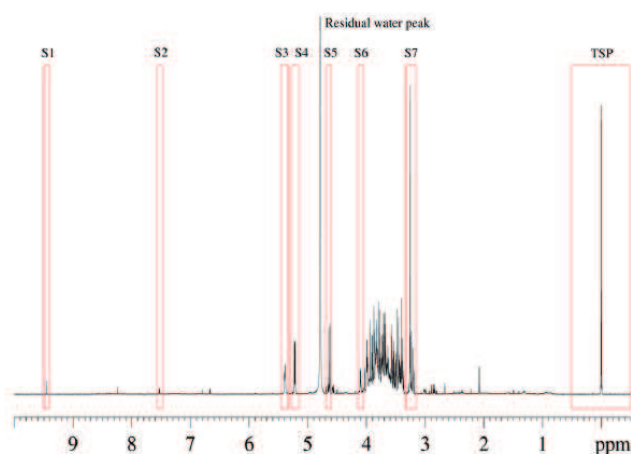

Figure 33. Typical 1D ^1H -NOESY spectrum for the present ILC

Step 4. Data and spectra submission

The procedure for data uploading reported in the guidelines is omitted in this paragraph. On the web site (<http://nmr.mxcs.it/index.php>), each participants uploaded NMR spectra and filled in the available form.

d. Samples preparation and analytical material description

Materials are carefully selected to meet the need of participants, and they are subjected to quality control. Details of test materials are given in the "Call for Partecipation". The test parameters are constantly reviewed to ensure they meet the needs of current laboratory testing and regulatory requirements. In order to check the quality of analytical materials, several factors such as homogeneity of the sample population, sample stability and all of the production steps are controlled. When possible, homogeneity tests are applied in accordance with IUPAC technical report "The international harmonized protocol for the proficiency testing of analytical chemistry laboratories". Test material batches are tested for

homogeneity for at least one test parameter where appropriate. Details of homogeneity tests performed and results are published on final report. In case of non-conformity, materials are retired. If this produces a delay, participants will be promptly apprised.

Samples were handled by qualified technical staff and poured in NMR tubes (Norell 509-UP 7). NMR tubes were five for each participant. Tubes were labelled with A, B, C, D, E. Tube A contained 0.7 mL of deuterated methanol 99.80 %D (CD₃OD, CAS number: 811-98-3). Tubes B and C contained two different wheat extracts in H₂O/D₂O (90/10, acidic solution at pH = 2.0 by hydrochloric acid). Tubes contained also sodium azide as biocide (CAS number: 26628-22-8; concentration ca. 15mg/100mL) and 3-(trimethylsilyl) propionic-2,2,3,3-d₄ acid sodium salt (TSP, CAS Number 24493-21-8; concentration ca. 0.2 mg/mL). Tubes D and E contained two different flour extracts in H₂O/D₂O (90/10 v/v, acidic solution at pH = 2.0 by hydrochloric acid). Tubes contained also sodium azide as biocide (CAS number: 26628-22-8; concentration ca. 15mg/100mL) and 3-(trimethylsilyl)propionic-2,2,3,3-d₄ acid sodium salt (CAS Number 24493-21-8; concentration ca. 0.2 mg/mL). Bulk solutions A-E were prepared using the same batch of D₂O. NMR tubes were filled with 0.7 mL solution, sealed and delivered to participants.

The exclusive use of the five tubes was for the interlaboratory comparison IS-NMR-ILC 001_2014. No different use was allowed.

e. Samples delivery

Samples are sent by an express courier guaranteeing delivery within two days. Shipping codes will be given to participants in order to follow the way of packs. Samples are sent in an appropriate packaging, to guarantee the integrity of materials during transport. After delivery, the only responsible for preservation of the sample is the participant. Participants must verify the integrity of the received analytical material within 24 h from delivery. Any kind of problem must be quickly communicated.

Each pack contained 5 sealed NMR tube (Norell 509-UP 7) labelled as A, B, C, D, E.

Samples delivery was managed by Euroma Multiservizi S.r.l in the period 2015/03/09 - 2015/03/27.

f. NMR analysis

Samples will be analyzed by participants, in accordance with methods and timetables provided by protocol and instructions. Each deviation from instructions, if any, must be declared to coordinator before the closure of comparison.

During the period for NMR spectra registration some participants declared problems. In particular:

- one participant (using one spectrometer) declared the impossibility to correctly set temperature during NMR measurements due to technical problems. However, measurements have been authorized and are considered in the present report;
- five participants asked for an extension period for NMR data collection due to unexpected technical problems which could be overcome in a short period. Extension period of 17 days was approved;
- four participants (using one spectrometer each) declared their impossibility to record NMR spectra due to unexpected technical problems which could not be overcome in a short period.

Moreover, two participants (using a total of three spectrometers) did not furnish results.

g. Submission of the results

Submission of the results will be possible by on line procedure using the form on website. After deadline, result submission is no longer possible.

In the present ILC, on line procedure was used for results submission by all participants.

h. Data elaboration

NMR data are submitted to statistical processing, in accordance with the appropriate statistical principles of reference normative.

i. Report publication

Results of the statistical elaboration of the NMR will be published on the website within 45 working days after deadline.

The report “Validation of a 1D ¹H-NOESY experiment for fingerprinting of wheat and flour”, vol. 1 of the series “NMR Interlaboratory Comparisons”, Ed. NeP Edizioni, Rome, was published in July 2015.

2.6.2 *Privacy and general data on participants*

An appropriate set of secret codes was elaborated and communicated in confidence by email to each participant. Secret codes refer to spectrometers used by each participant and are not related to the order of presentation of the participants in the following table.

Table 25. Participants submitting results listed in alphabetical order.

PARTICIPANT	LABORATORY NAME
7C – Consortium for NMR Research in Biotechnology and Material Science	
Aérial	Physico-chemistry
Aptuit S.r.l.	Comp. & Analytical Chemistry
Bruker BioSpin Corporation	Business Development Group, R&D Division
Bruker Italia S.r.l.	Laboratorio applicativo NMR
Chemical And Veterinary Investigation Agency Karlsruhe	NMR Labor
CNR – Istituto di Metodologie Chimiche	Laboratorio di risonanza magnetica “Annalaura Segre”
CNR – Istituto per lo Studio delle Macromolecole	Laboratorio NMR
Consorzio Interuniversitario Risonanze Magnetiche di Metallo Proteine – C.I.R.M.M.P.	FiorGen
ENEA – Trisaia Center	UTTRI-GENER NMR Lab
Eurofins	
Federal University of Paraná	UFPR NMR Center
Innovative Solutions S.r.l.	
Istituto Superiore di Sanità	Qualità dei farmaci chimici: controllo e valutazione
Istituto Zooprofilattico Sperimentale dell’Abruzzo e del Molise “G. Caporale”	Bromatologia, Residui alimenti per l’uomo e gli animali
Politecnico di Bari	DICATECh – Laboratorio NMR
Universidad Complutense de Madrid	CAY DE RMN Y RSE
Universidade de Aveiro - UAVR	CICECO – NMR metabolomics group

PARTICIPANT	LABORATORY NAME
Università degli Studi di Bari	Dipartimento di Chimica – MetalBioLab Chimica Bioinorganica
Università degli Studi di Bari	Dipartimento di Chimica – AFF
Università degli Studi di Cagliari	Laboratorio NMR
Università degli Studi di Messina	Laboratorio NMR
Università degli Studi di Milano Bicocca	BioNMR Lab
Università degli studi di Modena e Reggio Emilia	Centro Interdipartimentale Grandi Strumenti – C.I.G.S.
Università degli Studi di Padova	Dipartimento di Scienze Chimiche – Laboratorio Interdipartimentale di Risonanza Magnetica Nucleare
Università degli Studi di Parma	Centro Interdipartimentale Misure “Giuseppe Casnati”
Università degli Studi di Verona	Laboratorio NMR
Università di Roma La Sapienza	Dipartimento di Chimica - Laboratorio NMR
Università di Roma La Sapienza	Dipartimento di Chimica - Laboratorio NMR
University of Copenhagen	Department of Food Science – Magnetic Island

Table 26.

Participants	
Registered Participants	37
Available NMR spectrometers	46
Delivered set of samples	46
Spectrometers producing results	39

Table 27.

Magnetic Field (Larmor frequency for ^1H)	
9.4 T (400 MHz)	16
11.7 T (500 MHz)	7
14.1 T (600 MHz)	14
16.4 T (700 MHz)	2

Table 28.

Spectrometer manufacturers	
Bruker	35
Varian	4

2.6.3 Statistical elaboration

NMR signal integrals were scaled to the TSP integral and the corresponding ($I_{\text{signal}}/I_{\text{TSP}}$) values were uploaded on the website <http://nmr.mxcs.it>, specifically designed and validated for data elaboration in agreement with internationally accepted requirements (Horwitz, 1995). ($I_{\text{signal}}/I_{\text{TSP}}$) values were uploaded reporting at least four decimal places. The five ($I_{\text{signal}}/I_{\text{TSP}}$) replicates collected for each signal and for each NMR tube were submitted to the Shapiro-Wilk test to ascertain their normal distribution and to Huber, Dixon, and Grubbs tests for identification of possible outliers. Grubbs tests refer to application of both the classical Grubbs test identifying one outlier and the double Grubbs test which enables the identification of two outliers. Data identified as outliers by all of the four tests were not considered in successive steps. After removing outliers, $I_{\text{signal}}/I_{\text{TSP}}$ values were used to determine their mean value and the corresponding standard deviation which were considered as intra-laboratory uncertainties of the method. Then, results from all participants were submitted to data elaboration for proficiency test and for determination of the assigned $I_{\text{signal}}/I_{\text{TSP}}$ values. The lack of official reference data for this case study prompted us to determine assigned values as consensus values from participants. (ISO 17043:2010) Thus, for each $I_{\text{signal}}/I_{\text{TSP}}$ ratio, according to the flowchart suggested by Horwitz (1995), the 39 standard deviation values were submitted to the Cochran test (provided that all of the 5 replicates successfully passed the abovementioned tests for outliers) with the aim to identify and remove outliers for successive calculations. In turn, mean $I_{\text{signal}}/I_{\text{TSP}}$ values from data sets which passed successfully the Cochran test were submitted to Huber test with the aim to further refine the quality of the results. All sets of data successfully passing the abovementioned outlier tests were submitted to the Shapiro-Wilk test to ascertain the normal distribution of the population (data were always normal distributed after refinement by the Cochran and Huber tests) and were used to calculate, for each signal, the assigned $I_{\text{signal}}/I_{\text{TSP}}$ value (Average), (ISO 13528:2005 and ISO 5725:1994) the interlaboratory standard deviation (σ_{ILC}), the coefficient of variation (CV%), the repeatability variance, the reproducibility limits and other statistical parameters.

2.6.4 Performance assessment

In the present ILC, z-scores were calculated for proficiency testing. z-score is defined as

$$z = \frac{(x_i - \bar{x})}{\sigma} \quad (28)$$

where x_i is the mean $I_{\text{signal}}/I_{\text{TSP}}$ value determined by using the i^{th} data set, \bar{x} is the assigned $I_{\text{signal}}/I_{\text{TSP}}$ value (average), and σ is the interlaboratory standard deviation, all referred to a single NMR signal.

For z scores, the following limits were considered:(ISO 13528:2005 and ISO 5725:1994)

- $|z| \leq 2.0$ indicates "satisfactory" performance;
- $2.0 < |z| < 3.0$ indicates "questionable" performance;
- $|z| \geq 3.0$ indicates "unsatisfactory" performance.

In the latter case, suitable actions are required to identify and to solve the analytical problems.

2.6.5 Homogeneity and stability test

The lack of statistical data from previous comparisons, and in particular of a standard deviation for proficiency assessment, prevented the execution of homogeneity test according to agreed procedures (Thompson et al, 2006).The tests for the so-called "sufficient homogeneity" are aimed to ascertain, before sample delivery, the negligibility of the variation in composition with respect to variation introduced by the measurements conducted by participants. In the present ILC, the only way to evaluate the sufficient homogeneity of the samples was to compare, after data acquisition, the variation in composition with the variation introduced by the measurements conducted by participants. For this evaluation, an additional point to issue is the selection of the proper NMR signal ratio. In principle, all the selected signal ratios should be considered for evaluation of homogeneity, but at this first stage of ILC organization it is not possible to know the dependence of the signal ratio magnitude on both the heterogeneous character of the sample and the

variations due to the measurements. In tables 29-32, for each signal and for each NMR tube, the sampling standard deviation S_{sam} accounting for variation in composition is reported along with σ_{ILC} . S_{sam} was determined considering all the prepared NMR tubes (46 per signal per tube) before delivery. The condition $S_{sam} < 0.3 \cdot \sigma_{ILC}$ was used to evaluate the suitability of the signal for homogeneity evaluation. Under this condition, it derives that z-scores would be inflated by the heterogeneity by somewhat less than 0.1 units (Thompson et al, 2006). The standard deviation accounting for stability (S_{stab}) was also reported. It was determined by three measurements within three months. The magnitude of S_{stab} is lower than the corresponding ILC with the exception of the signal ratio I_{S6}/I_{TSP} for tubes B and C.

Table 29. Homogeneity test for tube B

Signal ratio	Average	S_{sam}	S_{stab}	σ_{ILC}	Limit ($0.3 \cdot \sigma_{ILC}$)	Evaluation
I_{S1}/I_{TSP}	0.02626	0.00399	0.00087	0.00212	0.00064	Non appropriate
I_{S2}/I_{TSP}	0.03765	0.00143	0.00314	0.00451	0.00135	Non appropriate
I_{S3}/I_{TSP}	0.56499	0.01087	0.01015	0.08910	0.02673	Appropriate
I_{S4}/I_{TSP}	0.74968	0.01261	0.01219	0.06380	0.01914	Appropriate
I_{S5}/I_{TSP}	0.87843	0.01302	0.02092	0.22933	0.06880	Appropriate
I_{S6}/I_{TSP}	0.29320	0.00358	0.09486	0.04059	0.01218	Appropriate
I_{S7}/I_{TSP}	2.52876	0.02122	0.03801	0.14126	0.04238	Appropriate

Table 30. Homogeneity test for tube C

Signal ratio	Average	S_{sam}	S_{stab}	σ_{ILC}	Limit ($0.3 \cdot \sigma_{ILC}$)	Evaluation
I_{S1}/I_{TSP}	0.03918	0.00127	0.00065	0.00249	0.00075	Non appropriate
I_{S2}/I_{TSP}	0.05362	0.00214	0.00319	0.00639	0.00192	Non appropriate
I_{S3}/I_{TSP}	0.54392	0.01579	0.01656	0.06772	0.02032	Appropriate
I_{S4}/I_{TSP}	0.53821	0.01545	0.02249	0.05475	0.01642	Appropriate
I_{S5}/I_{TSP}	0.62481	0.01487	0.01234	0.16279	0.04884	Appropriate
I_{S6}/I_{TSP}	0.33682	0.00688	0.09965	0.06419	0.01926	Appropriate
I_{S7}/I_{TSP}	2.33688	0.04037	0.03449	0.17810	0.05343	Appropriate

Table 31. Homogeneity test for tube D

Signal ratio	Average	S _{sam}	S _{stab}	σ_{ILC}	Limit (0.3* σ_{ILC})	Evaluation
I _{S1} /I _{TSP}	0.03409	0.00141	0.00046	0.00218	0.00065	Non appropriate
I _{S2} /I _{TSP}	0.04410	0.00167	0.00057	0.00392	0.00117	Non appropriate
I _{S3} /I _{TSP}	0.86759	0.01482	0.00321	0.11282	0.03384	Appropriate
I _{S4} /I _{TSP}	1.02061	0.01531	0.00455	0.09174	0.02752	Appropriate
I _{S5} /I _{TSP}	1.22506	0.01271	0.02593	0.31189	0.09357	Appropriate
I _{S6} /I _{TSP}	0.33451	0.00350	0.00148	0.03617	0.01085	Appropriate
I _{S7} /I _{TSP}	3.00935	0.02720	0.02243	0.24648	0.07394	Appropriate

Table 32. Homogeneity test for tube E

Signal ratio	Average	S _{sam}	S _{stab}	σ_{ILC}	Limit (0.3* σ_{ILC})	Evaluation
I _{S1} /I _{TSP}	0.03831	0.00124	0.00091	0.00242	0.00073	Non appropriate
I _{S2} /I _{TSP}	0.05008	0.00157	0.00189	0.00518	0.00155	Non appropriate
I _{S3} /I _{TSP}	0.40371	0.00821	0.01024	0.07357	0.02207	Appropriate
I _{S4} /I _{TSP}	0.60666	0.01113	0.01344	0.06122	0.01837	Appropriate
I _{S5} /I _{TSP}	0.70581	0.01676	0.03716	0.19066	0.05720	Appropriate
I _{S6} /I _{TSP}	0.29557	0.00371	0.00519	0.04203	0.01261	Appropriate
I _{S7} /I _{TSP}	2.30293	0.02751	0.04909	0.17705	0.05312	Appropriate

2.6.6 Temperature calibration

In table 33 the operating temperature values of each participant are listed as average temperature (along with the corresponding standard deviation and percentage relative standard deviation) calculated considering the available 5 replicates. Compliance conditions required $T_{average} = 298.00 \pm 0.10$ K. Values highlighted in yellow indicate non compliant operative conditions.

Table 33.

Tube		A	
Lab Code	T _{average}	Standard deviation	Relative Std.dev
C5	297,98	0,03	0,009%
E3	298,46	0,03	0,011%
A1	297,96	0,03	0,009%
H4	298,21	0,06	0,020%
G5	298,05	0,02	0,008%
B1	298,04	0,02	0,006%
D1	298,05	0,06	0,020%
C3	297,92	0,03	0,010%
B2	297,97	0,02	0,006%
F4	298,17	0,10	0,034%
D3	297,91	0,02	0,008%
G1	297,96	0,07	0,024%
E1	298,05	0,03	0,011%
E5	297,93	0,02	0,006%
B3	297,96	0,02	0,008%
A5	298,03	0,57	0,190%
A4	298,03	0,56	0,190%
H2	298,01	0,02	0,006%
B4	298,18	0,11	0,036%
F1	297,67	0,24	0,082%
G3	297,92	0,16	0,055%
D5	297,98	0,24	0,081%
F2	297,97	0,03	0,011%
C1	298,47	1,23	0,412%
E2	298,03	0,03	0,011%
A3	298,03	0,03	0,010%
F5	298,01	0,01	0,003%
F3	298,01	0,01	0,005%
H3	298,05	0,03	0,009%
G2	297,99	0,01	0,003%
D4	298,07	0,02	0,008%
G4	297,89	0,28	0,094%
C2	298,01	0,02	0,006%
C4	297,84	0,43	0,144%
H1	298,84	0,15	0,049%
A2	298,02	0,04	0,013%
E4	297,92	0,06	0,021%
D2	297,98	0,05	0,015%
B5*	298,00	0,05	0,016%

2.6.7 Results

Results are subdivided in four sections, one per NMR tube, and seven subsections, one per signal ratio. Each section contains a summary table, a z-score table and a z-score plot. The summary tables list the following parameters: Total number of data sets, Outliers, Number of data sets considered for statistics, Degrees of freedom, Average, Interlaboratory standard deviation, CV%, Minimum, Maximum, Range, Median, Repeatability variance, Interlaboratory variance, Reproducibility variance, Confidence interval, Minimum confidence limit, Maximum confidence limit, Reproducibility limit.

The z-score tables show the participant performances assessed by z-score. Values highlighted in cyan were identified as outliers according to Cochran test while those highlighted in violet were identified as outliers according to Huber test. Participant marked with an asterisk submitted non compliant signal ratio in terms of number of decimal places (2 decimal places instead of the expected 4). This resulted in null standard deviations in many cases. However, these non compliant data were always considered as outliers, independently from the outcome of the Cochran and Huber tests, and were included in the general data elaboration.

2.6.8 Tube B

Table 34.

Tube B	
Is₁/I_{TSP}	
Total number of data sets	39
Outliers	9
Number of data sets considered for statistics	30
Degrees of freedom	29
Average	0.02626
Interlaboratory standard deviation	0.00212
CV%	8.1
Minimum	0.02207
Maximum	0.03070
Range	0.00863
Median	0.02610
Repeatability variance	0.0000045901
Interlaboratory variance	0.0000035952
Reproducibility variance	0.0000081853
Confidence interval	0.00178
Minimum confidence limit	0.02537
Maximum confidence limit	0.02714
Reproducibility limit	0.00826

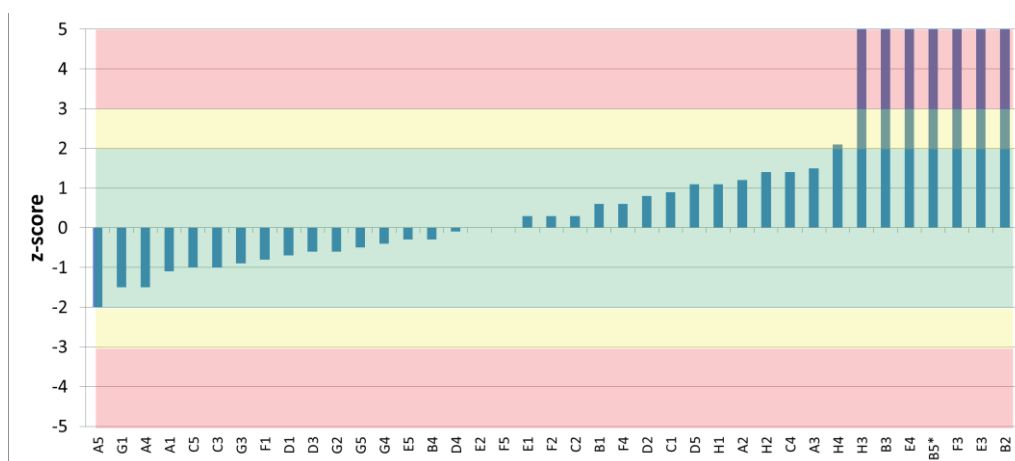

Figure 34. Is₁/I_{TSP}

Table 35.

Tube		B	
Integral ratio		Is1/ItSP	
Lab Code	Average	Standard deviation	Z-score
C5	0,02420	0,00123	-1.0
E3	2,63706	0,13928	1228.9
A1	0,02383	0,00604	-1.1
H4	0,03070	0,00085	2.1
G5	0,02520	0,00024	-0.5
B1	0,02751	0,00134	0.6
D1	0,02471	0,00059	-0.7
C3	0,02409	0,00077	-1.0
B2	2,70651	0,09294	1261.6
F4	0,02753	0,00039	0.6
D3	0,02493	0,00363	-0.6
G1	0,02312	0,00344	-1.5
E1	0,02680	0,00055	0.3
E5	0,02558	0,00111	-0.3
B3	0,05428	0,00431	13.2
A5	0,02207	0,00120	-2.0
A4	0,02301	0,00112	-1.5
H2	0,02924	0,00249	1.4
B4	0,02551	0,00154	-0.3
F1	0,02458	0,00393	-0.8
G3	0,02425	0,00137	-0.9
D5	0,02860	0,00152	1.1
F2	0,02698	0,00036	0.3
C1	0,02820	0,00095	0.9
E2	0,02616	0,00088	0.0
A3	0,02938	0,00314	1.5
F5	0,02628	0,00221	0.0
F3	2,54874	0,09627	1187.4
H3	0,04214	0,01531	7.5
G2	0,02506	0,00079	-0.6
D4	0,02604	0,00076	-0.1
G4	0,02542	0,00363	-0.4
C2	0,02682	0,00451	0.3
C4	0,02919	0,00400	1.4
H1	0,02852	0,00058	1.1
A2	0,02883	0,00680	1.2
E4	0,07580	0,00759	23.3
D2	0,02800	0,00274	0.8
B5*	0,09000	0,00000	30.0

Table 36.

Tube B	
Is₂/I_{TSP}	
Total number of data sets	39
Outliers	7
Number of data sets considered for statistics	32
Degrees of freedom	31
Average	0.03765
Interlaboratory standard deviation	0.00451
CV%	12.0
Minimum	0.02850
Maximum	0.04382
Range	0.01532
Median	0.03926
Repeatability variance	0.0000094645
Interlaboratory variance	0.0000184435
Reproducibility variance	0.0000279080
Confidence interval	0.00318
Minimum confidence limit	0.03607
Maximum confidence limit	0.03924
Reproducibility limit	0.01522

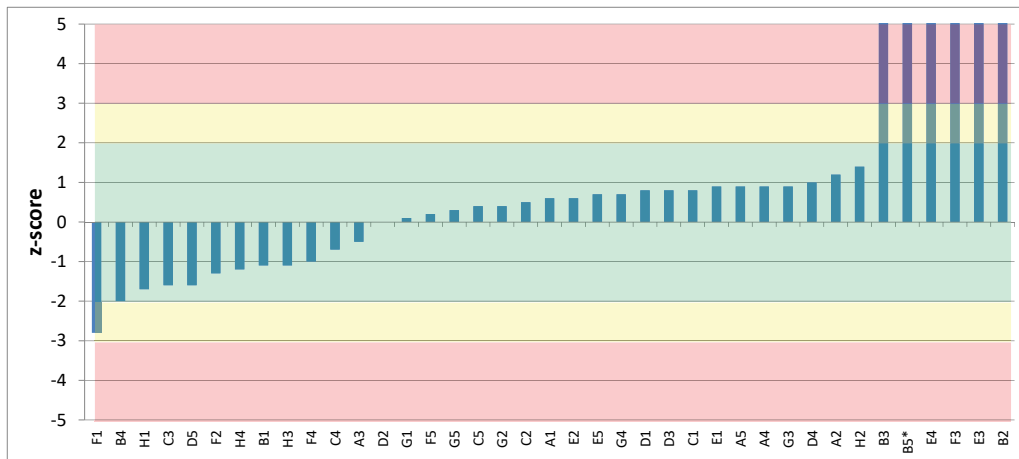

Figure 35. Is₂/I_{TSP}

Table 37.

Tube		B	
Integral ratio		Isz/ItSP	
Lab Code	Average	Standard deviation	Z-score
C5	0,03928	0,00270	0.4
E3	2,94878	0,35098	645.5
A1	0,04023	0,00609	0.6
H4	0,03206	0,00112	-1.2
G5	0,03880	0,00076	0.3
B1	0,03277	0,00084	-1.1
D1	0,04134	0,00050	0.8
C3	0,03051	0,00141	-1.6
B2	3,36674	0,31351	738.2
F4	0,03335	0,00032	-1.0
D3	0,04133	0,00264	0.8
G1	0,03826	0,00692	0.1
E1	0,04150	0,00135	0.9
E5	0,04070	0,00330	0.7
B3	0,06382	0,00544	5.8
A5	0,04164	0,00150	0.9
A4	0,04190	0,00140	0.9
H2	0,04382	0,00219	1.4
B4	0,02850	0,00396	-2.0
F1	0,02488	0,00524	-2.8
G3	0,04165	0,00077	0.9
D5	0,03040	0,00167	-1.6
F2	0,03170	0,00123	-1.3
C1	0,04121	0,00066	0.8
E2	0,04018	0,00140	0.6
A3	0,03552	0,00207	-0.5
F5	0,03862	0,00070	0.2
F3	0,30588	0,00997	59.5
H3	0,03276	0,00473	-1.1
G2	0,03924	0,00108	0.4
D4	0,04224	0,00072	1.0
G4	0,04072	0,00356	0.7
C2	0,03972	0,00644	0.5
C4	0,03431	0,00550	-0.7
H1	0,03002	0,00168	-1.7
A2	0,04301	0,00580	1.2
E4	0,07660	0,00715	8.6
D2	0,03760	0,00207	0.0
B5*	0,07600	0,00548	8.5

Table 38.

Tube B	
Is3/ITSP	
Total number of data sets	39
Outliers	9
Number of data sets considered for statistics	30
Degrees of freedom	29
Average	0.56499
Interlaboratory standard deviation	0.08910
CV%	15.8
Minimum	0.38344
Maximum	0.74550
Range	0.36206
Median	0.58661
Repeatability variance	0.0005281285
Interlaboratory variance	0.0078329502
Reproducibility variance	0.0083610787
Confidence interval	0.05676
Minimum confidence limit	0.53661
Maximum confidence limit	0.59337
Reproducibility limit	0.26409

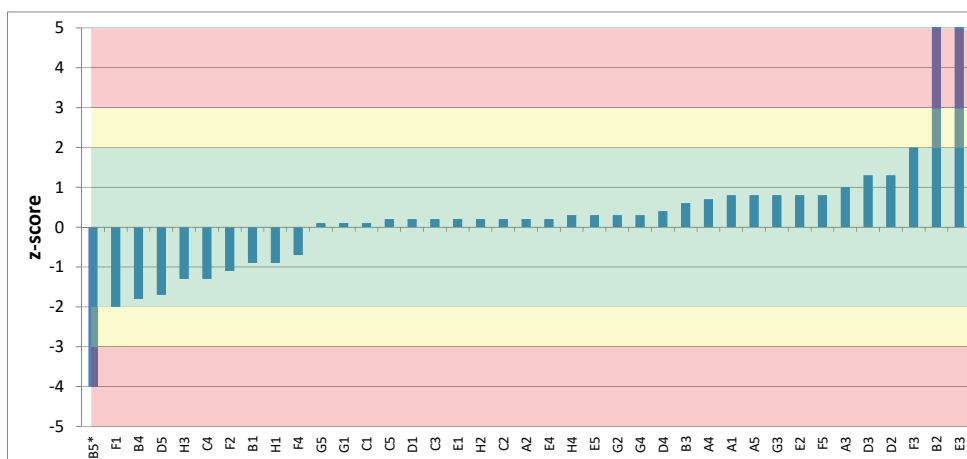

Figure 36. Is3/ITSP

Table 39.

Tube		B	
Integral ratio		Is _s /I _{TSP}	
Lab Code	Average	Standard deviation	Z-score
C5	0,5855	0,0498	0.2
E3	56,1503	2,2329	623.9
A1	0,6390	0,0525	0.8
H4	0,5916	0,0437	0.3
G5	0,5704	0,0090	0.1
B1	0,4834	0,0224	-0.9
D1	0,5790	0,0055	0.2
C3	0,5868	0,0093	0.2
B2	49,6125	0,5406	550.5
F4	0,5029	0,0050	-0.7
D3	0,6843	0,0393	1.3
G1	0,5719	0,1497	0.1
E1	0,5797	0,0145	0.2
E5	0,5919	0,0620	0.3
B3	0,6174	0,0379	0.6
A5	0,6393	0,0088	0.8
A4	0,6246	0,0099	0.7
H2	0,5868	0,0136	0.2
B4	0,4006	0,0183	-1.8
F1	0,3834	0,0367	-2.0
G3	0,6361	0,0203	0.8
D5	0,4174	0,0276	-1.7
F2	0,4648	0,0056	-1.1
C1	0,5704	0,0069	0.1
E2	0,6350	0,0179	0.8
A3	0,6513	0,0193	1.0
F5	0,6372	0,0645	0.8
F3	0,7455	0,0150	2.0
H3	0,4448	0,0155	-1.3
G2	0,5876	0,0049	0.3
D4	0,5996	0,0050	0.4
G4	0,5903	0,0297	0.3
C2	0,5864	0,0369	0.2
C4	0,4499	0,0351	-1.3
H1	0,4841	0,0049	-0.9
A2	0,5793	0,0313	0.2
E4	0,5796	0,0616	0.2
D2	0,6768	0,0324	1.3
B5*	0,2060	0,0152	-4.0

Table 40.

Tube B	
Is₄/I_{TSP}	
Total number of data sets	39
Outliers	9
Number of data sets considered for statistics	30
Degrees of freedom	29
Average	0.74968
Interlaboratory standard deviation	0.06380
CV%	8.5
Minimum	0.63460
Maximum	0.88120
Range	0.24660
Median	0.74787
Repeatability variance	0.0007467382
Interlaboratory variance	0.0039213138
Reproducibility variance	0.0046680520
Confidence interval	0.04241
Minimum confidence limit	0.72848
Maximum confidence limit	0.77089
Reproducibility limit	0.19732

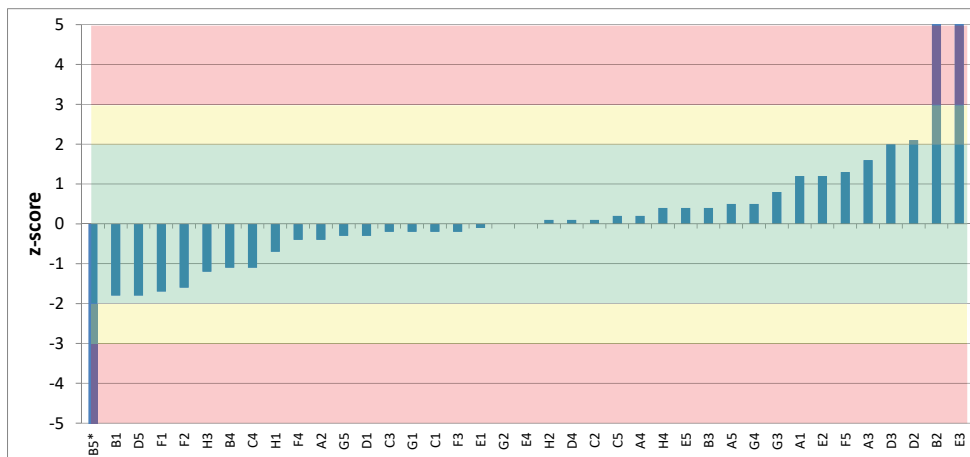

Figure 37. Is₄/I_{TSP}

Table 41.

Tube		B	
Integral ratio		Is4/I _{TSP}	
Lab Code	Average	Standard deviation	Z-score
C5	0,7608	0,0683	0.2
E3	74,6011	2,6281	1157.5
A1	0,8261	0,0774	1.2
H4	0,7776	0,0124	0.4
G5	0,7286	0,0118	-0.3
B1	0,6366	0,0188	-1.8
D1	0,7322	0,0123	-0.3
C3	0,7382	0,0143	-0.2
B2	71,0715	0,9789	1102.2
F4	0,7272	0,0058	-0.4
D3	0,8742	0,0514	2.0
G1	0,7345	0,2057	-0.2
E1	0,7453	0,0163	-0.1
E5	0,7726	0,0751	0.4
B3	0,7727	0,0171	0.4
A5	0,7843	0,0089	0.5
A4	0,7656	0,0103	0.2
H2	0,7504	0,0206	0.1
B4	0,6820	0,0332	-1.1
F1	0,6423	0,0696	-1.7
G3	0,8023	0,0356	0.8
D5	0,6346	0,0267	-1.8
F2	0,6499	0,0186	-1.6
C1	0,7382	0,0076	-0.2
E2	0,8254	0,0192	1.2
A3	0,8525	0,0173	1.6
F5	0,8315	0,0552	1.3
F3	0,7383	0,0343	-0.2
H3	0,6728	0,0042	-1.2
G2	0,7510	0,0117	0.0
D4	0,7538	0,0086	0.1
G4	0,7808	0,0348	0.5
C2	0,7531	0,0399	0.1
C4	0,6782	0,0451	-1.1
H1	0,7064	0,0104	-0.7
A2	0,7255	0,0409	-0.4
E4	0,7527	0,1467	0.0
D2	0,8812	0,0484	2.1
B5*	0,2120	0,0205	-8.4

Table 42.

Tube B	
I_{ss}/I_{TSP}	
Total number of data sets	39
Outliers	7
Number of data sets considered for statistics	32
Degrees of freedom	31
Average	0.87843
Interlaboratory standard deviation	0.22933
CV%	26.1
Minimum	0.24200
Maximum	1.29178
Range	1.04978
Median	0.91704
Repeatability variance	0.0030903940
Interlaboratory variance	0.0519751204
Reproducibility variance	0.0550655144
Confidence interval	0.14104
Minimum confidence limit	0.80791
Maximum confidence limit	0.94895
Reproducibility limit	0.67597

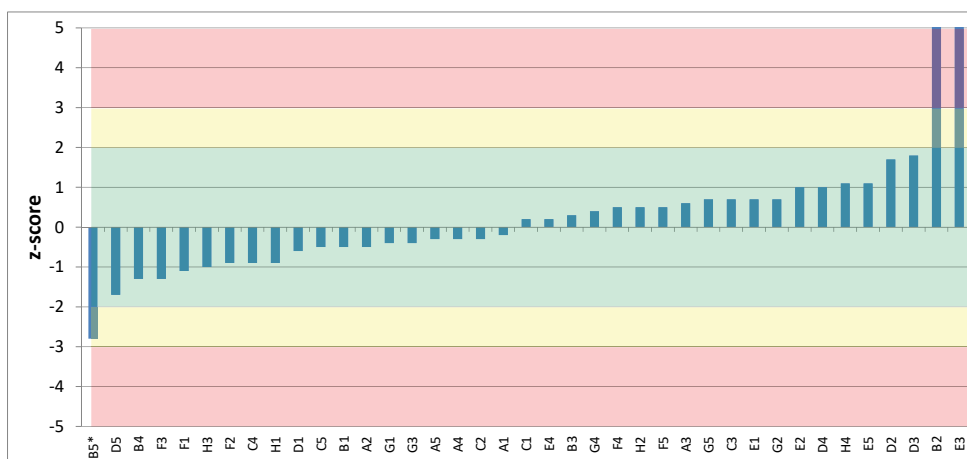

Figure 38. I_{ss}/I_{TSP}

Table 43.

Tube		B	
Integral ratio		I _{SS} /I _{TSP}	
Lab Code	Average	Standard deviation	Z-score
C5	0,759	0,124	-0.5
E3	94,673	3,081	409.0
A1	0,829	0,186	-0.2
H4	1,139	0,031	1.1
G5	1,031	0,042	0.7
B1	0,764	0,022	-0.5
D1	0,743	0,037	-0.6
C3	1,030	0,022	0.7
B2	94,378	2,334	407.7
F4	0,991	0,023	0.5
D3	1,292	0,098	1.8
G1	0,791	0,238	-0.4
E1	1,041	0,017	0.7
E5	1,130	0,101	1.1
B3	0,948	0,055	0.3
A5	0,818	0,012	-0.3
A4	0,806	0,012	-0.3
H2	0,991	0,094	0.5
B4	0,589	0,043	-1.3
F1	0,619	0,066	-1.1
G3	0,783	0,081	-0.4
D5	0,500	0,130	-1.7
F2	0,668	0,082	-0.9
C1	0,913	0,023	0.2
E2	1,119	0,037	1.0
A3	1,011	0,020	0.6
F5	0,993	0,243	0.5
F3	0,577	0,025	-1.3
H3	0,648	0,032	-1.0
G2	1,047	0,022	0.7
D4	1,100	0,026	1.0
G4	0,972	0,025	0.4
C2	0,812	0,104	-0.3
C4	0,662	0,059	-0.9
H1	0,664	0,050	-0.9
A2	0,766	0,087	-0.5
E4	0,921	0,104	0.2
D2	1,274	0,012	1.7
B5*	0,242	0,020	-2.8

Table 44.

Tube B	
Is₆/ITSP	
Total number of data sets	39
Outliers	16
Number of data sets considered for statistics	23
Degrees of freedom	22
Average	0.29320
Interlaboratory standard deviation	0.04059
CV%	13.8
Minimum	0.20814
Maximum	0.35960
Range	0.15146
Median	0.30812
Repeatability variance	0.0001353657
Interlaboratory variance	0.0016207838
Reproducibility variance	0.0017561495
Confidence interval	0.03006
Minimum confidence limit	0.27818
Maximum confidence limit	0.30823
Reproducibility limit	0.12260

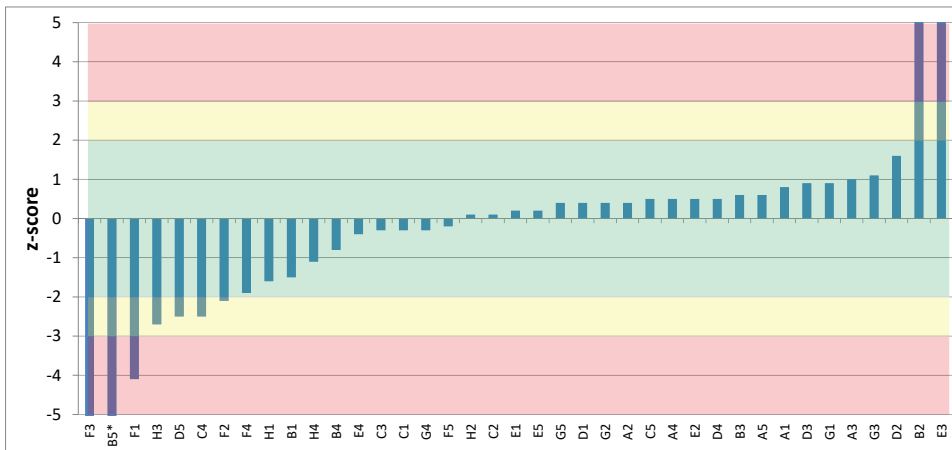

Figure 39. Is₆/ITSP

Table 45.

Tube		B	
Integral ratio		Is ₆ /I _{TSP}	
Lab Code	Average	Standard deviation	Z-score
C5	0,3119	0,0226	0.5
E3	26,2382	1,6483	639.1
A1	0,3249	0,0544	0.8
H4	0,2471	0,0029	-1.1
G5	0,3081	0,0112	0.4
B1	0,2313	0,0122	-1.5
D1	0,3084	0,0090	0.4
C3	0,2799	0,0129	-0.3
B2	21,1218	0,4162	513.1
F4	0,2146	0,0046	-1.9
D3	0,3284	0,0205	0.9
G1	0,3305	0,0388	0.9
E1	0,3028	0,0073	0.2
E5	0,3026	0,0178	0.2
B3	0,3160	0,0391	0.6
A5	0,3192	0,0024	0.6
A4	0,3115	0,0025	0.5
H2	0,2991	0,0251	0.1
B4	0,2618	0,0370	-0.8
F1	0,1269	0,0372	-4.1
G3	0,3363	0,0170	1.1
D5	0,1930	0,0107	-2.5
F2	0,2081	0,0033	-2.1
C1	0,2810	0,0047	-0.3
E2	0,3138	0,0138	0.5
A3	0,3327	0,0090	1.0
F5	0,2834	0,0292	-0.2
F3	0,0333	0,0046	-6.4
H3	0,1855	0,0037	-2.7
G2	0,3076	0,0077	0.4
D4	0,3145	0,0049	0.5
G4	0,2828	0,0137	-0.3
C2	0,2977	0,0633	0.1
C4	0,1933	0,0188	-2.5
H1	0,2301	0,0164	-1.6
A2	0,3113	0,0095	0.4
E4	0,2758	0,0426	-0.4
D2	0,3596	0,0048	1.6
B5*	0,0820	0,0110	-5.2

Table 46.

Tube B	
Is7/ItSP	
Total number of data sets	39
Outliers	12
Number of data sets considered for statistics	27
Degrees of freedom	26
Average	2.52876
Interlaboratory standard deviation	0.14126
CV%	5.58600
Minimum	2.24255
Maximum	2.87510
Range	0.63255
Median	2.53270
Repeatability variance	0.0019545571
Interlaboratory variance	0.0195624862
Reproducibility variance	0.0215170433
Confidence interval	0.09655
Minimum confidence limit	2.48049
Maximum confidence limit	2.57703
Reproducibility limit	0.42564

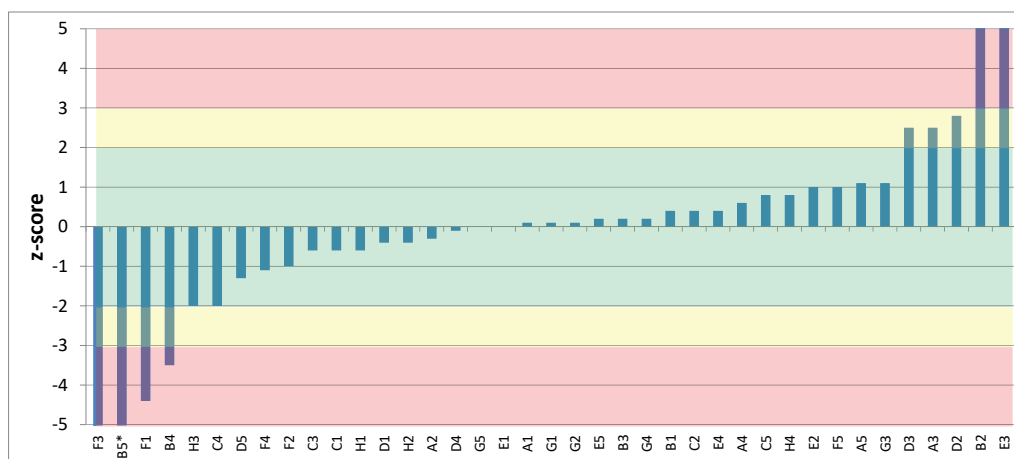

Figure 40. Is7/ItSP

Table 47.

Tube		B	
Integral ratio		Is7/IrSP	
Lab Code	Average	Standard deviation	Z-score
C5	2,6451	0,0890	0.8
E3	261,4345	8,7204	1832.9
A1	2,5462	0,1052	0.1
H4	2,6385	0,0298	0.8
G5	2,5218	0,0146	0.0
B1	2,5885	0,0668	0.4
D1	2,4755	0,0184	-0.4
C3	2,4453	0,0468	-0.6
B2	240,0408	3,3574	1681.4
F4	2,3804	0,0027	-1.1
D3	2,8846	0,1680	2.5
G1	2,5476	0,3011	0.1
E1	2,5327	0,0152	0.0
E5	2,5531	0,0305	0.2
B3	2,5541	0,1109	0.2
A5	2,6881	0,0087	1.1
A4	2,6172	0,0122	0.6
H2	2,4758	0,0213	-0.4
B4	2,0400	0,0993	-3.5
F1	1,9017	0,2320	-4.4
G3	2,6848	0,0703	1.1
D5	2,3466	0,0207	-1.3
F2	2,3917	0,0021	-1.0
C1	2,4427	0,0165	-0.6
E2	2,6682	0,0370	1.0
A3	2,8751	0,0491	2.5
F5	2,6734	0,0812	1.0
F3	0,0239	0,0049	-17.7
H3	2,2450	0,0300	-2.0
G2	2,5458	0,0227	0.1
D4	2,5200	0,0099	-0.1
G4	2,5636	0,0316	0.2
C2	2,5851	0,1821	0.4
C4	2,2426	0,0397	-2.0
H1	2,4436	0,0414	-0.6
A2	2,4818	0,0772	-0.3
E4	2,5894	0,0844	0.4
D2	2,9286	0,1682	2.8
B5*	0,5560	0,0695	-14.0

2.6.9 Tube C

Table 48.

Tube C	
Is₁/ITSP	
Total number of data sets	39
Outliers	11
Number of data sets considered for statistics	28
Degrees of freedom	27
Average	0.03918
Interlaboratory standard deviation	0.00249
CV%	6.4
Minimum	0.03398
Maximum	0.04332
Range	0.00934
Median	0.03896
Repeatability variance	0.0000023260
Interlaboratory variance	0.0000057415
Reproducibility variance	0.0000080675
Confidence interval	0.00184
Minimum confidence limit	0.03826
Maximum confidence limit	0.04010
Reproducibility limit	0.00823

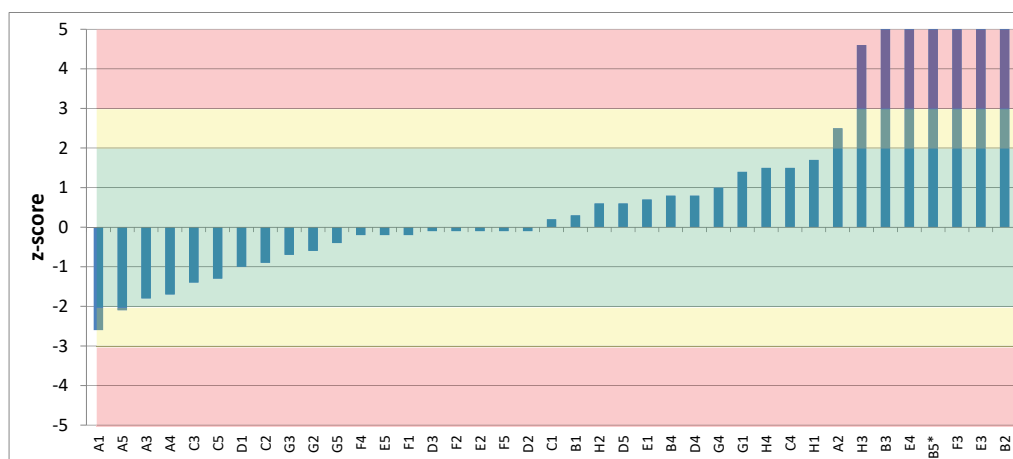

Figure 41. Is₁/ITSP

Table 49.

Tube		C	
Integral ratio		Is ₁ /I _{TSP}	
Lab Code	Average	Standard deviation	Z-score
C5	0,03582	0,00193	-1.3
E3	3,60146	0,21481	1429.9
A1	0,03272	0,00590	-2.6
H4	0,04284	0,00176	1.5
G5	0,03824	0,00090	-0.4
B1	0,04001	0,00183	0.3
D1	0,03680	0,00041	-1.0
C3	0,03559	0,00039	-1.4
B2	3,89741	0,05868	1548.7
F4	0,03874	0,00044	-0.2
D3	0,03898	0,00289	-0.1
G1	0,04272	0,00226	1.4
E1	0,04100	0,00051	0.7
E5	0,03866	0,00066	-0.2
B3	0,06828	0,00283	11.7
A5	0,03398	0,00119	-2.1
A4	0,03490	0,00127	-1.7
H2	0,04066	0,00179	0.6
B4	0,04121	0,00259	0.8
F1	0,03878	0,00133	-0.2
G3	0,03732	0,00087	-0.7
D5	0,04060	0,00114	0.6
F2	0,03894	0,00024	-0.1
C1	0,03958	0,00053	0.2
E2	0,03902	0,00147	-0.1
A3	0,03482	0,00855	-1.8
F5	0,03882	0,00049	-0.1
F3	2,36900	0,03624	935.2
H3	0,05056	0,00860	4.6
G2	0,03776	0,00055	-0.6
D4	0,04126	0,00138	0.8
G4	0,04164	0,00107	1.0
C2	0,03692	0,00143	-0.9
C4	0,04294	0,00208	1.5
H1	0,04332	0,00319	1.7
A2	0,04536	0,01154	2.5
E4	0,06902	0,00869	12.0
D2	0,03900	0,00424	-0.1
B5*	0,08800	0,00447	19.6

Table 50.

Tube C	
Is₂/I_{TSP}	
Total number of data sets	39
Outliers	11
Number of data sets considered for statistics	28
Degrees of freedom	27
Average	0.05362
Interlaboratory standard deviation	0.006392
CV%	11.92
Minimum	0.04167
Maximum	0.06200
Range	0.02033
Median	0.05620
Repeatability variance	0.0000033140
Interlaboratory variance	0.0000401823
Reproducibility variance	0.0000434963
Confidence interval	0.00426
Minimum confidence limit	0.05149
Maximum confidence limit	0.05575
Reproducibility limit	0.01911

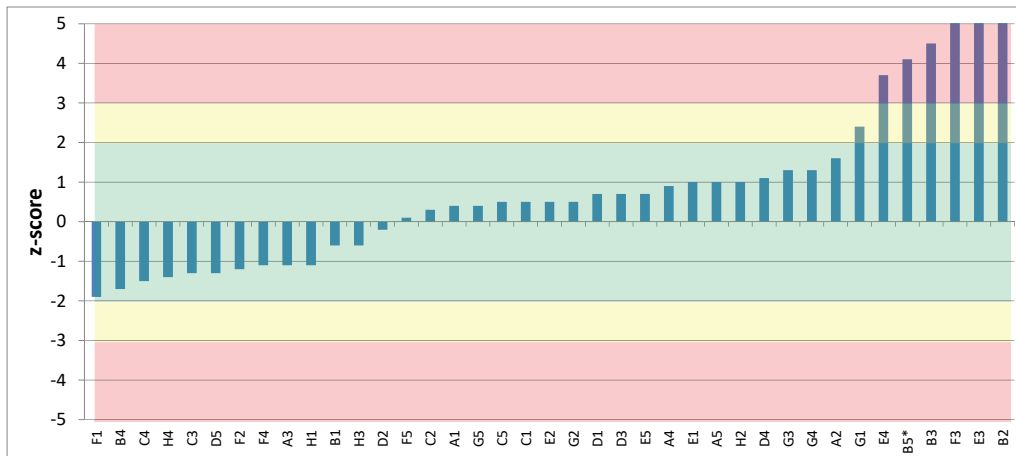

Figure 42. Is₂/I_{TSP}

Table 51.

Tube		C	
Integral ratio		Isz/I _{TSP}	
Lab Code	Average	Standard deviation	Z-score
C5	0,05652	0,00260	0.5
E3	4,08168	0,40017	630.3
A1	0,05611	0,00512	0.4
H4	0,04478	0,00179	-1.4
G5	0,05588	0,00221	0.4
B1	0,04957	0,00249	-0.6
D1	0,05780	0,00089	0.7
C3	0,04546	0,00122	-1.3
B2	4,75480	0,13314	735.6
F4	0,04643	0,00238	-1.1
D3	0,05779	0,00208	0.7
G1	0,06888	0,00629	2.4
E1	0,06032	0,00103	1.0
E5	0,05840	0,00186	0.7
B3	0,08244	0,00158	4.5
A5	0,05996	0,00165	1.0
A4	0,05971	0,00157	0.9
H2	0,05980	0,00222	1.0
B4	0,04280	0,00465	-1.7
F1	0,04167	0,00212	-1.9
G3	0,06200	0,00117	1.3
D5	0,04520	0,00217	-1.3
F2	0,04586	0,00089	-1.2
C1	0,05709	0,00048	0.5
E2	0,05690	0,00165	0.5
A3	0,04662	0,00963	-1.1
F5	0,05406	0,00054	0.1
F3	0,38260	0,02220	51.5
H3	0,04950	0,00225	-0.6
G2	0,05662	0,00036	0.5
D4	0,06044	0,00084	1.1
G4	0,06176	0,00144	1.3
C2	0,05528	0,00143	0.3
C4	0,04378	0,00187	-1.5
H1	0,04650	0,00201	-1.1
A2	0,06387	0,01072	1.6
E4	0,07700	0,00784	3.7
D2	0,05220	0,00356	-0.2
B5*	0,08000	0,00707	4.1

Table 52.

Tube C	
Is3/ITSP	
Total number of data sets	39
Outliers	6
Number of data sets considered for statistics	33
Degrees of freedom	32
Average	0.54392
Interlaboratory standard deviation	0.06772
CV%	12.5
Minimum	0.42015
Maximum	0.67400
Range	0.25385
Median	0.56252
Repeatability variance	0.0004506384
Interlaboratory variance	0.0044962241
Reproducibility variance	0.0049468625
Confidence interval	0.04163
Minimum confidence limit	0.52310
Maximum confidence limit	0.56473
Reproducibility limit	0.20237

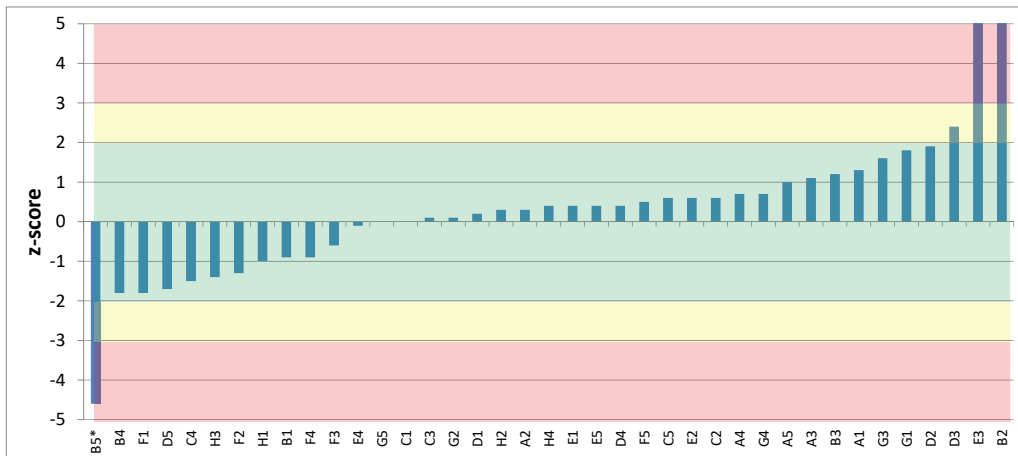

Figure 43. Is3/ITSP

Table 53.

Tube		C	
Integral ratio		Is ₃ /I _{TSP}	
Lab Code	Average	Standard deviation	Z-score
C5	0,5846	0,0281	0.6
E3	48,0898	4,7917	702.1
A1	0,6312	0,0378	1.3
H4	0,5682	0,0213	0.4
G5	0,5427	0,0114	0.0
B1	0,4826	0,0237	-0.9
D1	0,5543	0,0079	0.2
C3	0,5511	0,0372	0.1
B2	48,2522	0,7263	704.5
F4	0,4804	0,0031	-0.9
D3	0,7056	0,0544	2.4
G1	0,6646	0,0912	1.8
E1	0,5695	0,0085	0.4
E5	0,5678	0,0324	0.4
B3	0,6226	0,0135	1.2
A5	0,6092	0,0114	1.0
A4	0,5919	0,0145	0.7
H2	0,5625	0,0264	0.3
B4	0,4215	0,0167	-1.8
F1	0,4201	0,0188	-1.8
G3	0,6513	0,0253	1.6
D5	0,4294	0,0396	-1.7
F2	0,4549	0,0043	-1.3
C1	0,5441	0,0119	0.0
E2	0,5878	0,0131	0.6
A3	0,6160	0,0547	1.1
F5	0,5802	0,0209	0.5
F3	0,5058	0,0221	-0.6
H3	0,4465	0,0138	-1.4
G2	0,5504	0,0053	0.1
D4	0,5701	0,0099	0.4
G4	0,5944	0,0099	0.7
C2	0,5834	0,0222	0.6
C4	0,4414	0,0126	-1.5
H1	0,4741	0,0095	-1.0
A2	0,5637	0,0291	0.3
E4	0,5373	0,0345	-0.1
D2	0,6740	0,0203	1.9
B5*	0,2300	0,0200	-4.6

Table 54.

Tube C	
Is₄/It_{SP}	
Total number of data sets	39
Outliers	9
Number of data sets considered for statistics	30
Degrees of freedom	29
Average	0.53821
Interlaboratory standard deviation	0.05475
CV%	10.2
Minimum	0.43900
Maximum	0.66260
Range	0.22360
Median	0.54709
Repeatability variance	0.0003869745
Interlaboratory variance	0.0029196806
Reproducibility variance	0.0033066551
Confidence interval	0.03570
Minimum confidence limit	0.52037
Maximum confidence limit	0.55606
Reproducibility limit	0.16608

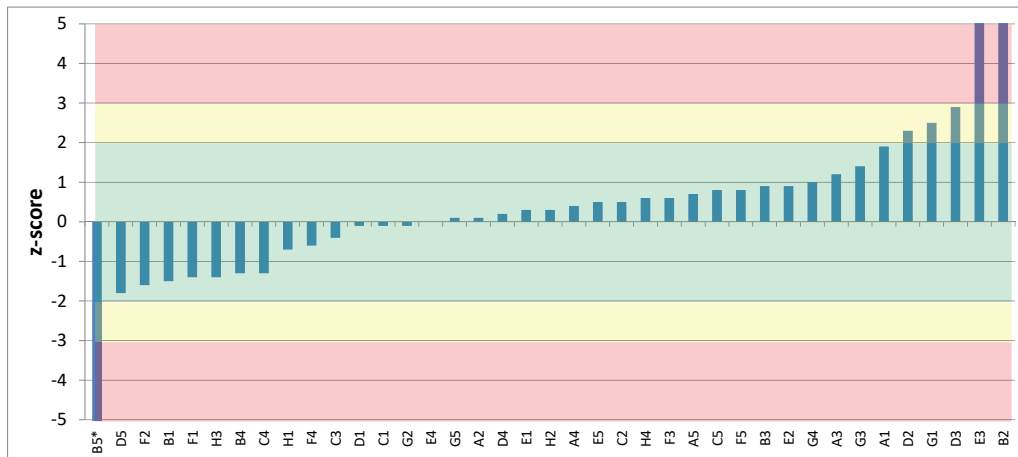

Figure 44. Is₄/It_{SP}

Table 55.

Tube		C	
Integral ratio		Is4/ITSP	
Lab Code	Average	Standard deviation	Z-score
C5	0,5815	0,0288	0.8
E3	48,9857	3,2240	885.0
A1	0,6405	0,0551	1.9
H4	0,5717	0,0210	0.6
G5	0,5414	0,0142	0.1
B1	0,4574	0,0192	-1.5
D1	0,5347	0,0082	-0.1
C3	0,5189	0,0206	-0.4
B2	50,1701	0,7514	906.6
F4	0,5054	0,0059	-0.6
D3	0,6968	0,0576	2.9
G1	0,6771	0,1200	2.5
E1	0,5563	0,0104	0.3
E5	0,5664	0,0352	0.5
B3	0,5858	0,0158	0.9
A5	0,5770	0,0109	0.7
A4	0,5607	0,0137	0.4
H2	0,5525	0,0465	0.3
B4	0,4693	0,0193	-1.3
F1	0,4606	0,0120	-1.4
G3	0,6127	0,0337	1.4
D5	0,4390	0,0378	-1.8
F2	0,4527	0,0123	-1.6
C1	0,5346	0,0115	-0.1
E2	0,5861	0,0147	0.9
A3	0,6046	0,0538	1.2
F5	0,5825	0,0260	0.8
F3	0,5694	0,0234	0.6
H3	0,4628	0,0167	-1.4
G2	0,5353	0,0079	-0.1
D4	0,5495	0,0129	0.2
G4	0,5939	0,0118	1.0
C2	0,5661	0,0244	0.5
C4	0,4657	0,0162	-1.3
H1	0,5018	0,0114	-0.7
A2	0,5446	0,0272	0.1
E4	0,5399	0,0524	0.0
D2	0,6626	0,0122	2.3
B5*	0,2140	0,0152	-5.9

Table 56.

Tube C	
I_{ss}/I_{TSP}	
Total number of data sets	39
Outliers	15
Number of data sets considered for statistics	24
Degrees of freedom	23
Average	0.62481
Interlaboratory standard deviation	0.16279
CV%	26.1
Minimum	0.22800
Maximum	0.93900
Range	0.71100
Median	0.64455
Repeatability variance	0.0005102349
Interlaboratory variance	0.0263994233
Reproducibility variance	0.0269096582
Confidence interval	0.11452
Minimum confidence limit	0.56755
Maximum confidence limit	0.68207
Reproducibility limit	0.47878

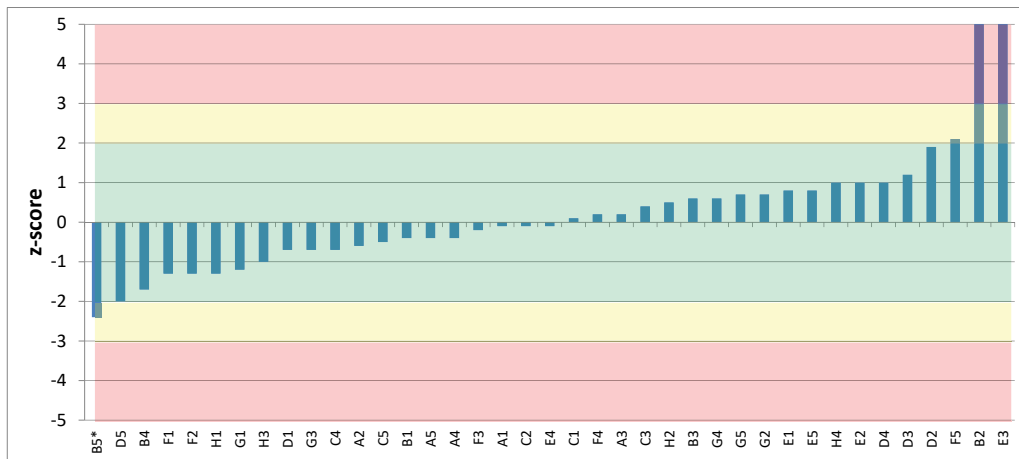

Figure 45. I_{ss}/I_{TSP}

Table 57.

Tube		C	
Integral ratio		I _{SS} /I _{TSP}	
Lab Code	Average	Standard deviation	Z-score
C5	0,5455	0,0412	-0.5
E3	63,5943	7,3593	386.8
A1	0,6112	0,1111	-0.1
H4	0,7918	0,0347	1.0
G5	0,7340	0,0253	0.7
B1	0,5544	0,0155	-0.4
D1	0,5107	0,0144	-0.7
C3	0,6953	0,0165	0.4
B2	62,4043	0,7822	379.5
F4	0,6528	0,0088	0.2
D3	0,8169	0,1810	1.2
G1	0,4357	0,2193	-1.2
E1	0,7496	0,0176	0.8
E5	0,7608	0,0258	0.8
B3	0,7161	0,0303	0.6
A5	0,5610	0,0108	-0.4
A4	0,5522	0,0084	-0.4
H2	0,6991	0,1233	0.5
B4	0,3541	0,0269	-1.7
F1	0,4158	0,0486	-1.3
G3	0,5101	0,0890	-0.7
D5	0,2972	0,0969	-2.0
F2	0,4176	0,0876	-1.3
C1	0,6363	0,0211	0.1
E2	0,7832	0,0160	1.0
A3	0,6599	0,0531	0.2
F5	0,9630	0,2443	2.1
F3	0,5921	0,0294	-0.2
H3	0,4646	0,0282	-1.0
G2	0,7418	0,0208	0.7
D4	0,7854	0,0157	1.0
G4	0,7171	0,0148	0.6
C2	0,6005	0,0581	-0.1
C4	0,5169	0,1099	-0.7
H1	0,4043	0,0112	-1.3
A2	0,5252	0,0257	-0.6
E4	0,6012	0,0795	-0.1
D2	0,9390	0,0150	1.9
B5*	0,2280	0,0286	-2.4

Table 58.

Tube C	
	Is₆/TSP
Total number of data sets	39
Outliers	9
Number of data sets considered for statistics	30
Degrees of freedom	29
Average	0.33682
Interlaboratory standard deviation	0.06419
CV%	19.1
Minimum	0.21598
Maximum	0.46060
Range	0.24462
Median	0.35581
Repeatability variance	0.0001705228
Interlaboratory variance	0.0040866252
Reproducibility variance	0.0042571480
Confidence interval	0.04050
Minimum confidence limit	0.31657
Maximum confidence limit	0.35707
Reproducibility limit	0.18844

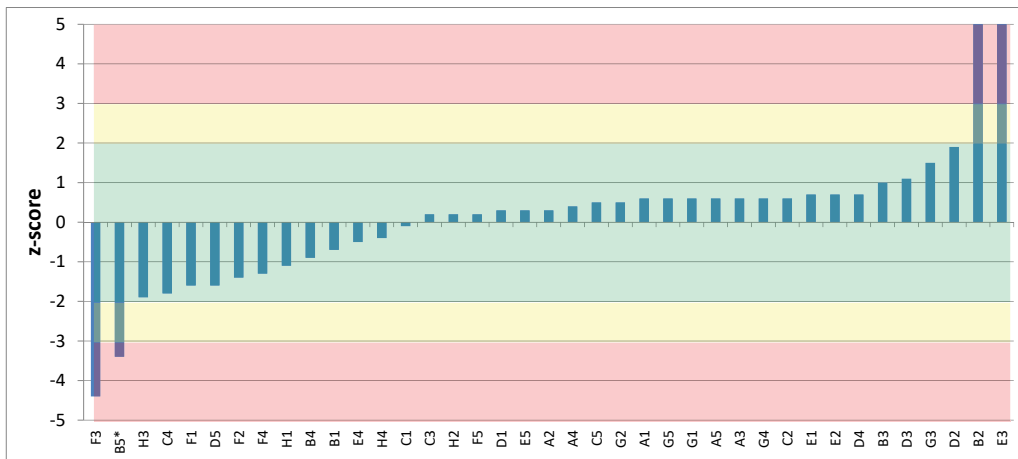

Figure 46. Is₆/TSP

Table 59.

Tube		C	
Integral ratio		Is ₆ /It _{SP}	
Lab Code	Average	Standard deviation	Z-score
C5	0,3695	0,0128	0.5
E3	34,0350	3,0935	525.0
A1	0,3733	0,0331	0.6
H4	0,3079	0,0235	-0.4
G5	0,3755	0,0130	0.6
B1	0,2926	0,0173	-0.7
D1	0,3567	0,0057	0.3
C3	0,3478	0,0224	0.2
B2	24,5066	0,2560	376.5
F4	0,2552	0,0059	-1.3
D3	0,4051	0,0113	1.1
G1	0,3732	0,0518	0.6
E1	0,3796	0,0028	0.7
E5	0,3557	0,0052	0.3
B3	0,4038	0,0098	1.0
A5	0,3729	0,0023	0.6
A4	0,3612	0,0047	0.4
H2	0,3506	0,0168	0.2
B4	0,2791	0,0358	-0.9
F1	0,2352	0,0123	-1.6
G3	0,4335	0,0079	1.5
D5	0,2346	0,0192	-1.6
F2	0,2493	0,0104	-1.4
C1	0,3333	0,0078	-0.1
E2	0,3827	0,0092	0.7
A3	0,3762	0,0328	0.6
F5	0,3480	0,0079	0.2
F3	0,0526	0,0010	-4.4
H3	0,2160	0,0066	-1.9
G2	0,3717	0,0051	0.5
D4	0,3822	0,0050	0.7
G4	0,3725	0,0177	0.6
C2	0,3756	0,0338	0.6
C4	0,2232	0,0217	-1.8
H1	0,2687	0,0059	-1.1
A2	0,3559	0,0144	0.3
E4	0,3030	0,0232	-0.5
D2	0,4606	0,0153	1.9
B5*	0,1160	0,0167	-3.4

Table 60.

Tube C	
Is7/ITSP	
Total number of data sets	39
Outliers	9
Number of data sets considered for statistics	30
Degrees of freedom	29
Average	2.33688
Interlaboratory standard deviation	0.17810
CV%	7.6
Minimum	1.98634
Maximum	2.77700
Range	0.79066
Median	2.34982
Repeatability variance	0.0017573614
Interlaboratory variance	0.0313674854
Reproducibility variance	0.0331248468
Confidence interval	0.11298
Minimum confidence limit	2.28039
Maximum confidence limit	2.39336
Reproducibility limit	0.52564

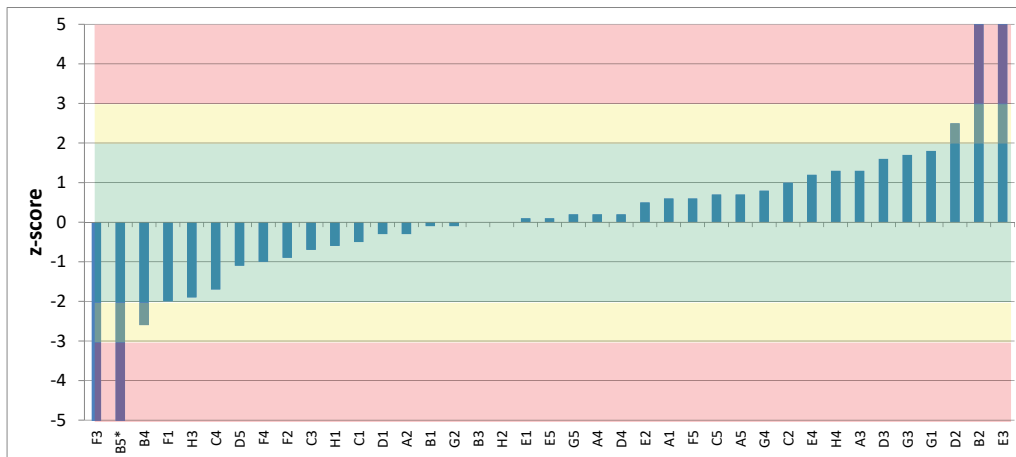

Figure 47. Is7/ITSP

Table 61.

Tube	C		
Integral ratio	Is7/I _{TSP}		
Lab Code	Average	Standard deviation	Z-score
C5	2,4640	0,0455	0.7
E3	218,3012	8,3242	1212.6
A1	2,4388	0,0535	0.6
H4	2,5765	0,1086	1.3
G5	2,3727	0,0686	0.2
B1	2,3160	0,0823	-0.1
D1	2,2838	0,0089	-0.3
C3	2,2210	0,0170	-0.7
B2	214,0738	1,1256	1188.9
F4	2,1504	0,0166	-1.0
D3	2,6282	0,1343	1.6
G1	2,6531	0,1481	1.8
E1	2,3573	0,0099	0.1
E5	2,3566	0,0223	0.1
B3	2,3431	0,0143	0.0
A5	2,4602	0,0177	0.7
A4	2,3799	0,0288	0.2
H2	2,3290	0,0473	0.0
B4	1,8733	0,1184	-2.6
F1	1,9863	0,0723	-2.0
G3	2,6416	0,0454	1.7
D5	2,1422	0,0268	-1.1
F2	2,1713	0,0180	-0.9
C1	2,2415	0,0395	-0.5
E2	2,4346	0,0357	0.5
A3	2,5659	0,1360	1.3
F5	2,4475	0,0265	0.6
F3	0,0391	0,0016	-12.9
H3	2,0043	0,0609	-1.9
G2	2,3267	0,0091	-0.1
D4	2,3688	0,0316	0.2
G4	2,4870	0,0304	0.8
C2	2,5094	0,0602	1.0
C4	2,0291	0,0065	-1.7
H1	2,2270	0,0199	-0.6
A2	2,2921	0,0504	-0.3
E4	2,5470	0,0268	1.2
D2	2,7770	0,0811	2.5
B5*	0,6320	0,0719	-9.6

2.6.10 Tube D

Table 62.

Tube D	
Is₁/I_{TSP}	
Total number of data sets	39
Outliers	11
Number of data sets considered for statistics	28
Degrees of freedom	27
Average	0.03409
Interlaboratory standard deviation	0.00218
CV%	6.4
Minimum	0.02761
Maximum	0.03748
Range	0.00987
Median	0.03468
Repeatability variance	0.0000024620
Interlaboratory variance	0.0000042525
Reproducibility variance	0.0000067145
Confidence interval	0.00167
Minimum confidence limit	0.03325
Maximum confidence limit	0.03493
Reproducibility limit	0.00751

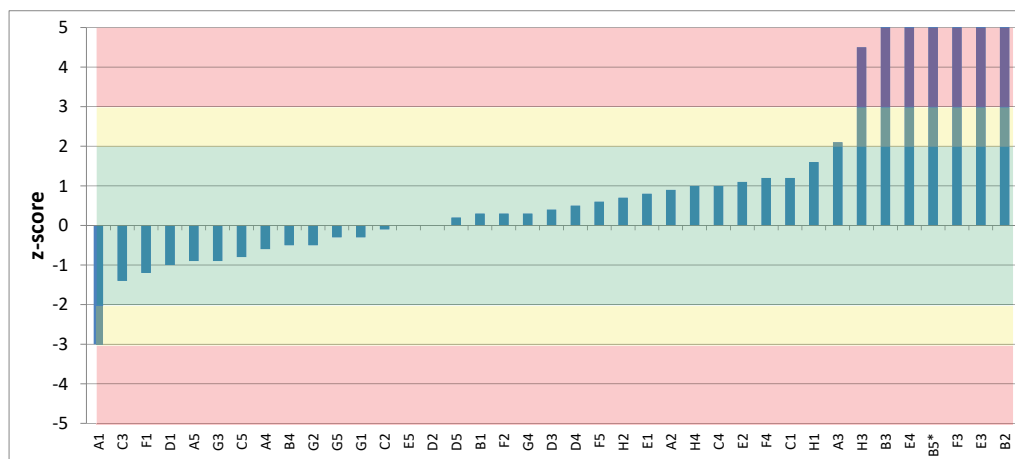

Figure 48. Is₁/I_{TSP}

Table 63.

Tube		D	
Integral ratio		I _{s1} /I _{TSP}	
Lab Code	Average	Standard deviation	Z-score
C5	0,03244	0,00209	-0.8
E3	3,26212	0,23150	1481.9
A1	0,02761	0,00292	-3.0
H4	0,03622	0,00209	1.0
G5	0,03334	0,00070	-0.3
B1	0,03477	0,00094	0.3
D1	0,03187	0,00059	-1.0
C3	0,03106	0,00092	-1.4
B2	3,45056	0,13305	1568.4
F4	0,03668	0,00288	1.2
D3	0,03497	0,00240	0.4
G1	0,03354	0,00338	-0.3
E1	0,03588	0,00058	0.8
E5	0,03402	0,00073	0.0
B3	0,06212	0,00851	12.9
A5	0,03210	0,00038	-0.9
A4	0,03270	0,00034	-0.6
H2	0,03554	0,00071	0.7
B4	0,03298	0,00206	-0.5
F1	0,03151	0,00227	-1.2
G3	0,03220	0,00111	-0.9
D5	0,03460	0,00207	0.2
F2	0,03476	0,00074	0.3
C1	0,03664	0,00136	1.2
E2	0,03640	0,00111	1.1
A3	0,03864	0,00508	2.1
F5	0,03538	0,00155	0.6
F3	3,04098	0,04989	1380.4
H3	0,04385	0,01123	4.5
G2	0,03310	0,00023	-0.5
D4	0,03526	0,00031	0.5
G4	0,03476	0,00079	0.3
C2	0,03392	0,00124	-0.1
C4	0,03632	0,00284	1.0
H1	0,03748	0,00145	1.6
A2	0,03607	0,00539	0.9
E4	0,06792	0,00887	15.5
D2	0,03400	0,00381	0.0
B5*	0,09000	0,00000	25.7

Table 64.

Tube D	
Is₂/TSP	
Total number of data sets	39
Outliers	10
Number of data sets considered for statistics	29
Degrees of freedom	28
Average	0.04410
Interlaboratory standard deviation	0.00392
CV%	8.89571
Minimum	0.03493
Maximum	0.04962
Range	0.01469
Median	0.04476
Repeatability variance	0.0000042055
Interlaboratory variance	0.0000145499
Reproducibility variance	0.0000187554
Confidence interval	0.00273
Minimum confidence limit	0.04273
Maximum confidence limit	0.04547
Reproducibility limit	0.01253

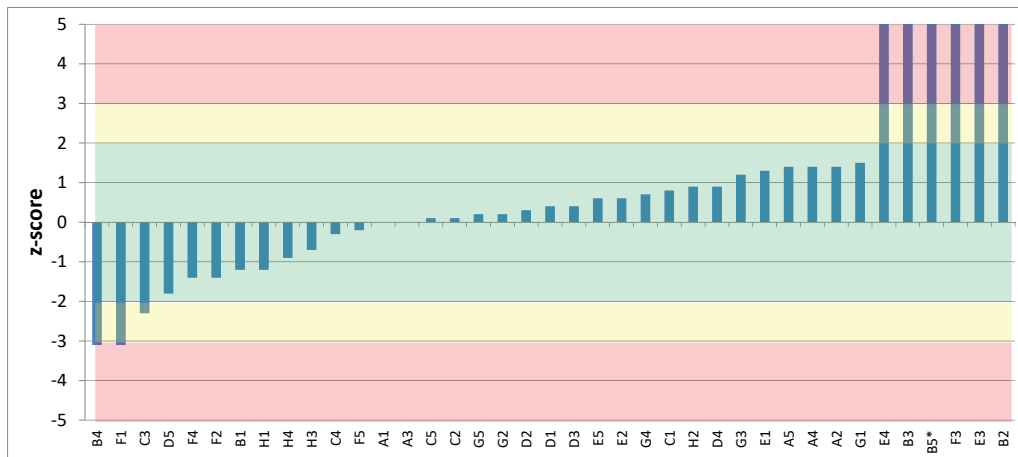

Figure 49. Is₂/TSP

Table 65.

Tube		D	
Integral ratio		Isz/Irsp	
Lab Code	Average	Standard deviation	Z-score
C5	0,04466	0,00124	0.1
E3	3,34780	0,20819	842.1
A1	0,04425	0,00365	0.0
H4	0,04044	0,00279	-0.9
G5	0,04476	0,00089	0.2
B1	0,03944	0,00063	-1.2
D1	0,04553	0,00071	0.4
C3	0,03493	0,00117	-2.3
B2	3,98950	0,11768	1005.7
F4	0,03866	0,00218	-1.4
D3	0,04562	0,00140	0.4
G1	0,05016	0,01007	1.5
E1	0,04914	0,00037	1.3
E5	0,04628	0,00344	0.6
B3	0,07090	0,01023	6.8
A5	0,04961	0,00139	1.4
A4	0,04962	0,00143	1.4
H2	0,04778	0,00184	0.9
B4	0,03209	0,00605	-3.1
F1	0,03187	0,00322	-3.1
G3	0,04879	0,00157	1.2
D5	0,03720	0,00311	-1.8
F2	0,03852	0,00056	-1.4
C1	0,04705	0,00115	0.8
E2	0,04662	0,00087	0.6
A3	0,04416	0,00326	0.0
F5	0,04324	0,00254	-0.2
F3	0,34088	0,00812	75.6
H3	0,04138	0,00422	-0.7
G2	0,04498	0,00065	0.2
D4	0,04762	0,00071	0.9
G4	0,04696	0,00172	0.7
C2	0,04432	0,00139	0.1
C4	0,04272	0,00130	-0.3
H1	0,03926	0,00222	-1.2
A2	0,04965	0,00623	1.4
E4	0,07042	0,00508	6.7
D2	0,04540	0,00288	0.3
B5*	0,07400	0,00548	7.6

Table 66

Tube D	
Is₃/I_{TSP}	
Total number of data sets	39
Outliers	5
Number of data sets considered for statistics	34
Degrees of freedom	33
Average	0.86759
Interlaboratory standard deviation	0.11282
CV%	13.0
Minimum	0.63057
Maximum	1.05540
Range	0.42483
Median	0.88884
Repeatability variance	0.0009030735
Interlaboratory variance	0.0125467678
Reproducibility variance	0.0134498413
Confidence interval	0.06762
Minimum confidence limit	0.83378
Maximum confidence limit	0.90140
Reproducibility limit	0.33330

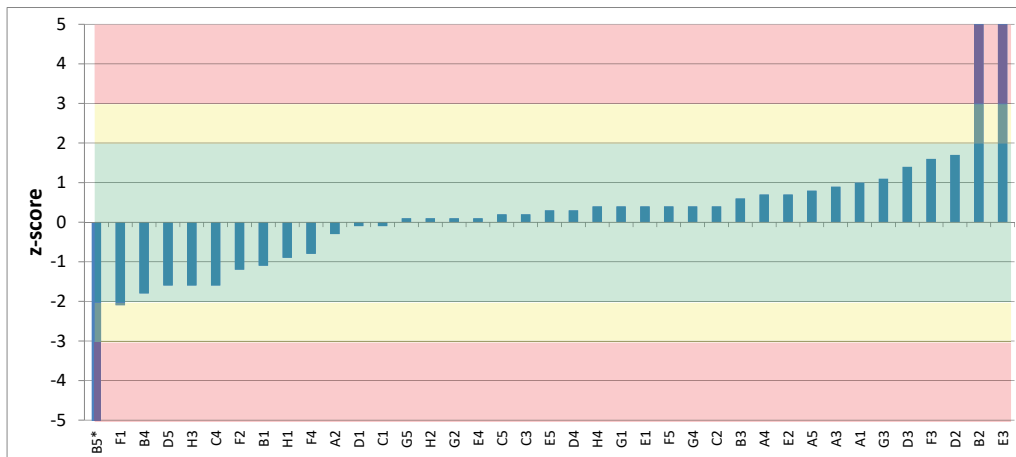

Figure 50. Is₃/I_{TSP}

Table 67.

Tube		D	
Integral ratio		Is3/ItSP	
Lab Code	Average	Standard deviation	Z-score
C5	0,8879	0,0208	0.2
E3	78,1639	4,9320	685.2
A1	0,9813	0,0603	1.0
H4	0,9074	0,0498	0.4
G5	0,8757	0,0155	0.1
B1	0,7406	0,0183	-1.1
D1	0,8526	0,0143	-0.1
C3	0,8898	0,0266	0.2
B2	77,1258	0,6998	676.0
F4	0,7780	0,0176	-0.8
D3	1,0210	0,0231	1.4
G1	0,9077	0,1567	0.4
E1	0,9102	0,0091	0.4
E5	0,8978	0,0573	0.3
B3	0,9304	0,0609	0.6
A5	0,9635	0,0060	0.8
A4	0,9430	0,0065	0.7
H2	0,8824	0,0180	0.1
B4	0,6634	0,0390	-1.8
F1	0,6306	0,0079	-2.1
G3	0,9896	0,0388	1.1
D5	0,6856	0,0391	-1.6
F2	0,7291	0,0118	-1.2
C1	0,8589	0,0071	-0.1
E2	0,9520	0,0194	0.7
A3	0,9728	0,0156	0.9
F5	0,9162	0,0649	0.4
F3	1,0528	0,0100	1.6
H3	0,6922	0,0207	-1.6
G2	0,8739	0,0084	0.1
D4	0,9026	0,0063	0.3
G4	0,9144	0,0318	0.4
C2	0,9118	0,0467	0.4
C4	0,6860	0,0389	-1.6
H1	0,7616	0,0128	-0.9
A2	0,8294	0,0376	-0.3
E4	0,8746	0,0345	0.1
D2	1,0554	0,0282	1.7
B5*	0,2640	0,0152	-5.4

Table 68.

Tube D	
Is₄/I_{TSP}	
Total number of data sets	39
Outliers	4
Number of data sets considered for statistics	35
Degrees of freedom	34
Average	1.02061
Interlaboratory standard deviation	0.09174
CV%	9.0
Minimum	0.85612
Maximum	1.23420
Range	0.37808
Median	1.02852
Repeatability variance	0.0012047494
Interlaboratory variance	0.0081757418
Reproducibility variance	0.0093804912
Confidence interval	0.05566
Minimum confidence limit	0.99278
Maximum confidence limit	1.04844
Reproducibility limit	0.27806

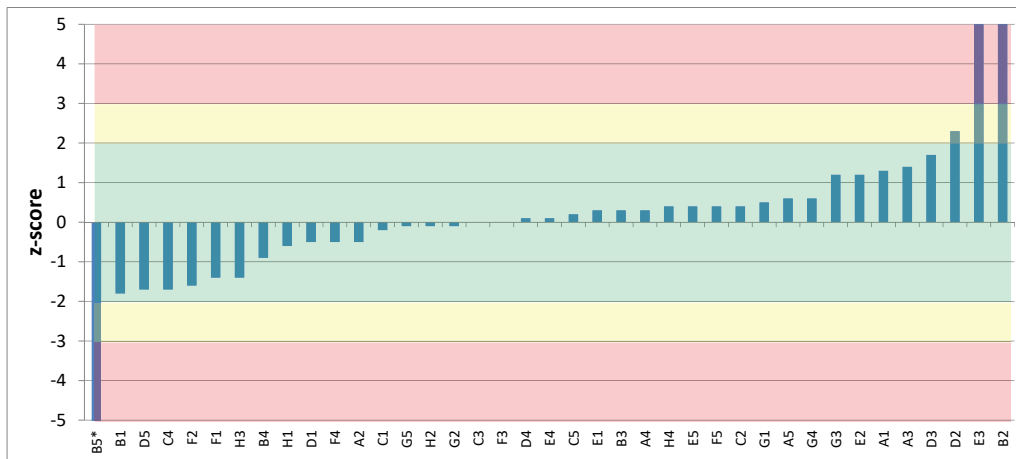

Figure 51. Is₄/I_{TSP}

Table 69.

Tube		D	
Integral ratio		Is4/ITSP	
Lab Code	Average	Standard deviation	Z-score
C5	1,0362	0,0252	0.2
E3	92,2372	7,0957	994.3
A1	1,1417	0,0613	1.3
H4	1,0583	0,0412	0.4
G5	1,0093	0,0190	-0.1
B1	0,8561	0,0270	-1.8
D1	0,9749	0,0179	-0.5
C3	1,0228	0,0431	0.0
B2	97,0381	1,1198	1046.6
F4	0,9785	0,0067	-0.5
D3	1,1777	0,0197	1.7
G1	1,0658	0,2029	0.5
E1	1,0499	0,0116	0.3
E5	1,0536	0,0697	0.4
B3	1,0487	0,0302	0.3
A5	1,0716	0,0067	0.6
A4	1,0486	0,0071	0.3
H2	1,0105	0,0270	-0.1
B4	0,9359	0,0377	-0.9
F1	0,8942	0,0266	-1.4
G3	1,1267	0,0628	1.2
D5	0,8602	0,0487	-1.7
F2	0,8773	0,0203	-1.6
C1	0,9989	0,0067	-0.2
E2	1,1326	0,0200	1.2
A3	1,1451	0,0124	1.4
F5	1,0618	0,0693	0.4
F3	1,0209	0,0127	0.0
H3	0,8912	0,0230	-1.4
G2	1,0102	0,0103	-0.1
D4	1,0285	0,0100	0.1
G4	1,0734	0,0299	0.6
C2	1,0562	0,0651	0.4
C4	0,8608	0,0193	-1.7
H1	0,9686	0,0183	-0.6
A2	0,9750	0,0119	-0.5
E4	1,0310	0,0610	0.1
D2	1,2342	0,0282	2.3
B5*	0,2800	0,0292	-8.1

Table 70.

Tube D	
Iss/ITSP	
	39
Outliers	8
Number of data sets considered for statistics	31
Degrees of freedom	30
Average	1.22506
Interlaboratory standard deviation	0.31189
CV%	25.5
Minimum	0.30800
Maximum	1.78200
Range	1.47400
Median	1.25069
Repeatability variance	0.0023075685
Interlaboratory variance	0.0968148820
Reproducibility variance	0.0991224505
Confidence interval	0.19226
Minimum confidence limit	1.12893
Maximum confidence limit	1.32119
Reproducibility limit	0.90808

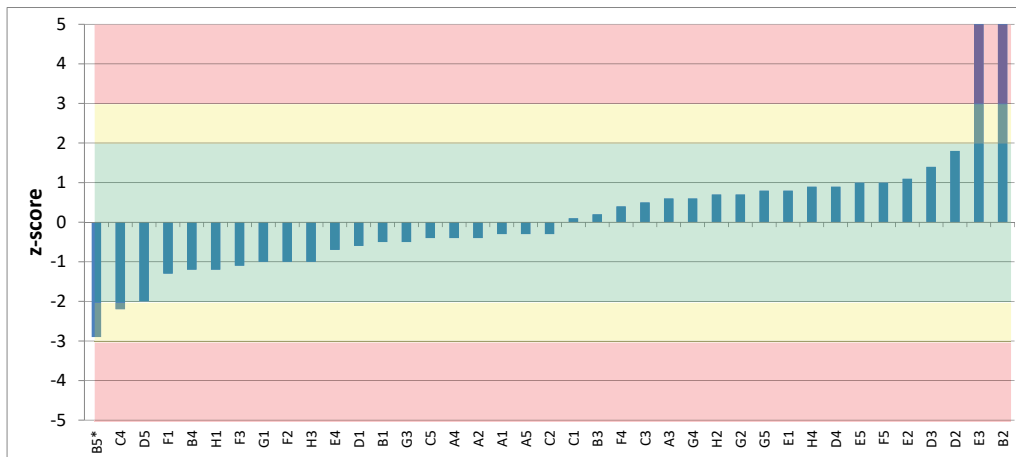

Figure 52. Iss/ITSP

Table 71.

Tube		D	
Integral ratio		I _{SS} /I _{TSP}	
Lab Code	Average	Standard deviation	Z-score
C5	1,0995	0,0339	-0.4
E3	127,4477	2,1634	404.7
A1	1,1238	0,0834	-0.3
H4	1,5131	0,0626	0.9
G5	1,4652	0,0318	0.8
B1	1,0632	0,0620	-0.5
D1	1,0306	0,0276	-0.6
C3	1,3815	0,0103	0.5
B2	129,5424	1,9204	411.4
F4	1,3491	0,0150	0.4
D3	1,6721	0,0683	1.4
G1	0,9254	0,2820	-1.0
E1	1,4719	0,0096	0.8
E5	1,5505	0,0893	1.0
B3	1,3013	0,0861	0.2
A5	1,1296	0,0050	-0.3
A4	1,1131	0,0050	-0.4
H2	1,4423	0,0408	0.7
B4	0,8643	0,0756	-1.2
F1	0,8285	0,0268	-1.3
G3	1,0796	0,0621	-0.5
D5	0,6048	0,2009	-2.0
F2	0,9073	0,1185	-1.0
C1	1,2507	0,0193	0.1
E2	1,5735	0,0347	1.1
A3	1,4227	0,0714	0.6
F5	1,5471	0,1758	1.0
F3	0,8896	0,0087	-1.1
H3	0,8980	0,0365	-1.0
G2	1,4447	0,0221	0.7
D4	1,5162	0,0279	0.9
G4	1,4175	0,0524	0.6
C2	1,1443	0,0736	-0.3
C4	0,5381	0,4384	-2.2
H1	0,8565	0,0164	-1.2
A2	1,0908	0,1971	-0.4
E4	0,9940	0,0232	-0.7
D2	1,7820	0,0428	1.8
B5*	0,3080	0,0356	-2.9

Table 72.

Tube D	
Is6/IrSP	
Total number of data sets	39
Outliers	18
Number of data sets considered for statistics	21
Degrees of freedom	20
Average	0.33451
Interlaboratory standard deviation	0.03617
CV%	10.8
Minimum	0.24402
Maximum	0.40220
Range	0.15818
Median	0.34724
Repeatability variance	0.0001756206
Interlaboratory variance	0.0012728828
Reproducibility variance	0.0014485034
Confidence interval	0.02857
Minimum confidence limit	0.32023
Maximum confidence limit	0.34880
Reproducibility limit	0.11193

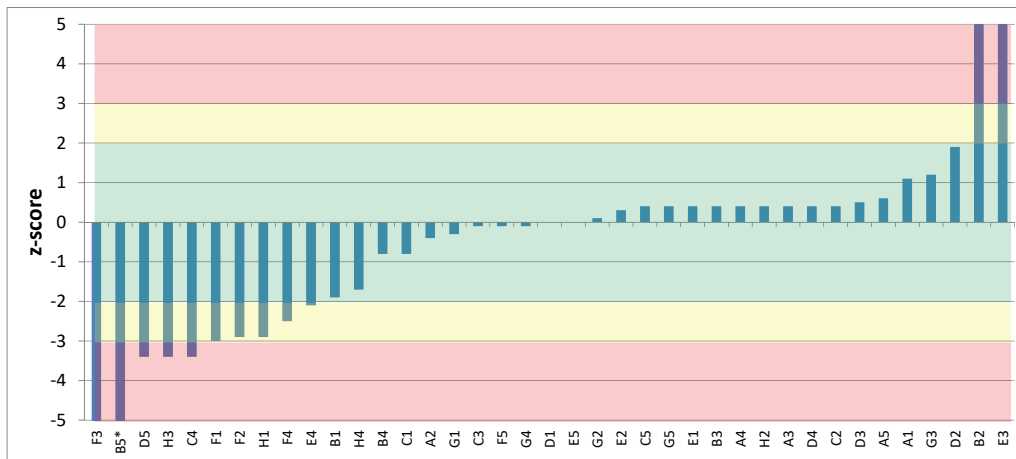

Figure 53. Is6/IrSP

Table 73

Tube	D		
Integral ratio	I ₆₆ /I _{TSP}		
Lab Code	Average	Standard deviation	Z-score
C5	0,3481	0,0175	0.4
E3	29,6168	1,4855	809.7
A1	0,3758	0,0354	1.1
H4	0,2735	0,0125	-1.7
G5	0,3499	0,0082	0.4
B1	0,2643	0,0109	-1.9
D1	0,3337	0,0059	0.0
C3	0,3321	0,0252	-0.1
B2	24,4148	0,2549	665.8
F4	0,2440	0,0045	-2.5
D3	0,3511	0,0129	0.5
G1	0,3222	0,0684	-0.3
E1	0,3484	0,0035	0.4
E5	0,3339	0,0219	0.0
B3	0,3473	0,0491	0.4
A5	0,3548	0,0024	0.6
A4	0,3475	0,0022	0.4
H2	0,3472	0,0063	0.4
B4	0,3048	0,0653	-0.8
F1	0,2244	0,0189	-3.0
G3	0,3770	0,0155	1.2
D5	0,2110	0,0103	-3.4
F2	0,2310	0,0028	-2.9
C1	0,3070	0,0041	-0.8
E2	0,3464	0,0168	0.3
A3	0,3475	0,0096	0.4
F5	0,3326	0,0388	-0.1
F3	0,0406	0,0026	-8.1
H3	0,2111	0,0231	-3.4
G2	0,3367	0,0072	0.1
D4	0,3490	0,0050	0.4
G4	0,3303	0,0192	-0.1
C2	0,3484	0,0480	0.4
C4	0,2112	0,0086	-3.4
H1	0,2313	0,0050	-2.9
A2	0,3218	0,0327	-0.4
E4	0,2576	0,0765	-2.1
D2	0,4022	0,0236	1.9
B5*	0,0980	0,0045	-6.5

Table 74.

Tube D	
Is7/ITSP	
Total number of data sets	39
Outliers	9
Number of data sets considered for statistics	30
Degrees of freedom	29
Average	3.00935
Interlaboratory standard deviation	0.24648
CV%	8.2
Minimum	2.34445
Maximum	3.55100
Range	1.20655
Median	3.00810
Repeatability variance	0.0041281032
Interlaboratory variance	0.0599276947
Reproducibility variance	0.0640557979
Confidence interval	0.15711
Minimum confidence limit	2.93080
Maximum confidence limit	3.08790
Reproducibility limit	0.73096

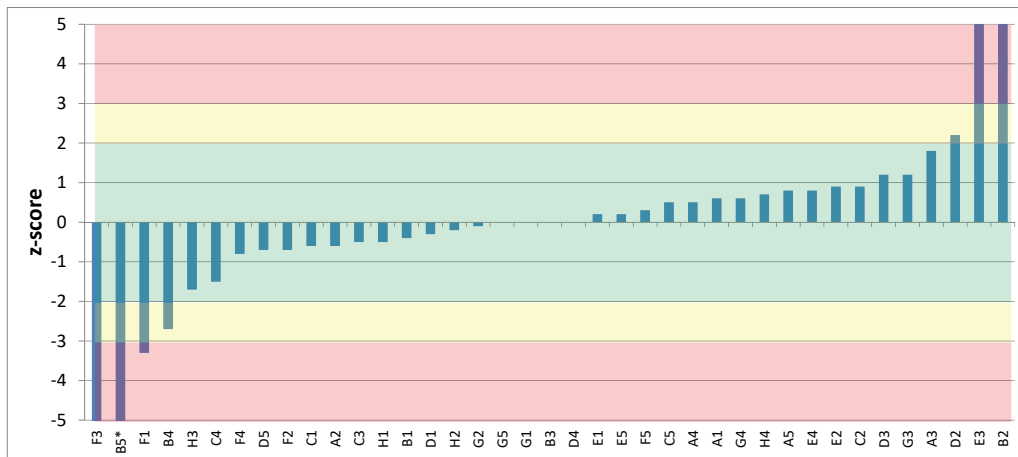

Figure 54. Is7/ITSP

Table 75.

Tube		D	
Integral ratio		Is7/IrSP	
Lab Code	Average	Standard deviation	Z-score
C5	3,1332	0,0377	0.5
E3	261,8702	26,5675	1050.2
A1	3,1645	0,0843	0.6
H4	3,1927	0,1406	0.7
G5	3,0139	0,0494	0.0
B1	2,9173	0,0169	-0.4
D1	2,9301	0,0281	-0.3
C3	2,8868	0,0305	-0.5
B2	281,4222	2,3956	1129.5
F4	2,8138	0,0307	-0.8
D3	3,3082	0,0586	1.2
G1	3,0178	0,2196	0.0
E1	3,0471	0,0218	0.2
E5	3,0559	0,0352	0.2
B3	3,0170	0,1590	0.0
A5	3,1956	0,0160	0.8
A4	3,1241	0,0142	0.5
H2	2,9594	0,0359	-0.2
B4	2,3445	0,1116	-2.7
F1	2,2017	0,0861	-3.3
G3	3,3095	0,2288	1.2
D5	2,8302	0,0223	-0.7
F2	2,8426	0,0215	-0.7
C1	2,8710	0,0257	-0.6
E2	3,2206	0,0551	0.9
A3	3,4471	0,1151	1.8
F5	3,0842	0,1155	0.3
F3	0,0323	0,0031	-12.1
H3	2,5875	0,1308	-1.7
G2	2,9903	0,0142	-0.1
D4	3,0023	0,0119	0.0
G4	3,1451	0,0463	0.6
C2	3,2220	0,1154	0.9
C4	2,6360	0,0463	-1.5
H1	2,8808	0,0081	-0.5
A2	2,8714	0,0343	-0.6
E4	3,2039	0,0774	0.8
D2	3,5510	0,1307	2.2
B5*	0,6440	0,0643	-9.6

2.6.11 Tube E

Table 76.

Tube E	
Is₁/I_{TSP}	
Total number of data sets	39
Outliers	12
Number of data sets considered for statistics	27
Degrees of freedom	26
Average	0.03831
Interlaboratory standard deviation	0.00242
CV%	6.3
Minimum	0.03281
Maximum	0.04412
Range	0.01131
Median	0.03868
Repeatability variance	0.0000029225
Interlaboratory variance	0.0000052575
Reproducibility variance	0.0000081800
Confidence interval	0.00188
Minimum confidence limit	0.03737
Maximum confidence limit	0.03925
Reproducibility limit	0.00830

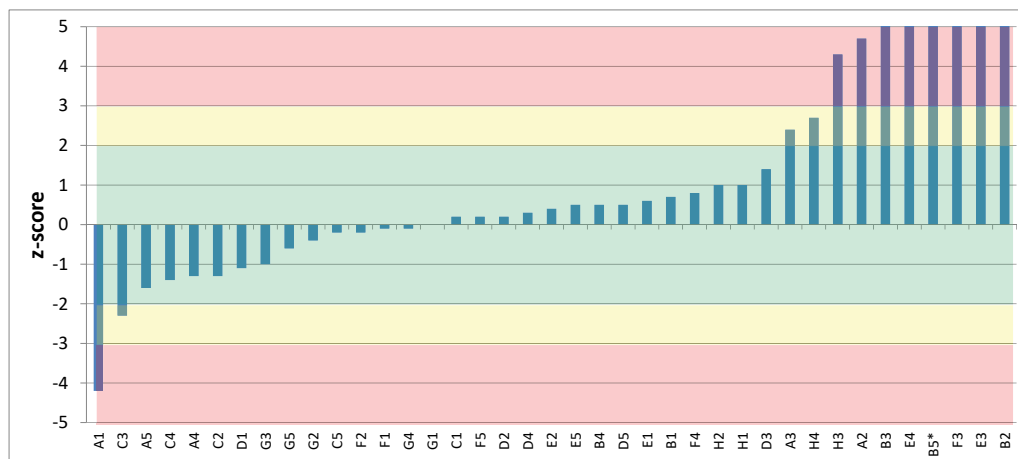

Figure 55. Is₁/I_{TSP}

Table 77.

Tube		E	
Integral ratio		Is1/ITSP	
Lab Code	Average	Standard deviation	Z-score
C5	0,03778	0,00194	-0.2
E3	3,45814	0,24715	1414.9
A1	0,02822	0,00376	-4.2
H4	0,04480	0,00728	2.7
G5	0,03688	0,00013	-0.6
B1	0,03992	0,00151	0.7
D1	0,03554	0,00064	-1.1
C3	0,03281	0,00124	-2.3
B2	3,73431	0,09979	1529.2
F4	0,04030	0,00130	0.8
D3	0,04167	0,00113	1.4
G1	0,03840	0,00105	0.0
E1	0,03970	0,00074	0.6
E5	0,03950	0,00208	0.5
B3	0,06682	0,00347	11.8
A5	0,03455	0,00110	-1.6
A4	0,03515	0,00105	-1.3
H2	0,04064	0,00143	1.0
B4	0,03940	0,00538	0.5
F1	0,03818	0,00103	-0.1
G3	0,03599	0,00121	-1.0
D5	0,03960	0,00167	0.5
F2	0,03772	0,00089	-0.2
C1	0,03879	0,00077	0.2
E2	0,03930	0,00120	0.4
A3	0,04412	0,00350	2.4
F5	0,03868	0,00134	0.2
F3	2,29444	0,02547	933.4
H3	0,04875	0,00632	4.3
G2	0,03726	0,00040	-0.4
D4	0,03910	0,00035	0.3
G4	0,03800	0,00371	-0.1
C2	0,03512	0,00318	-1.3
C4	0,03496	0,00477	-1.4
H1	0,04080	0,00176	1.0
A2	0,04962	0,02811	4.7
E4	0,07566	0,00908	15.5
D2	0,03880	0,00286	0.2
B5*	0,09000	0,00000	21.4

Table 78.

Tube E	
Is₂/ITSP	
Total number of data sets	39
Outliers	11
Number of data sets considered for statistics	28
Degrees of freedom	27
Average	0.05008
Interlaboratory standard deviation	0.00518
CV%	10.3
Minimum	0.04083
Maximum	0.05678
Range	0.01595
Median	0.05103
Repeatability variance	0.0000040672
Interlaboratory variance	0.0000260263
Reproducibility variance	0.0000300935
Confidence interval	0.00355
Minimum confidence limit	0.04831
Maximum confidence limit	0.05185
Reproducibility limit	0.01589

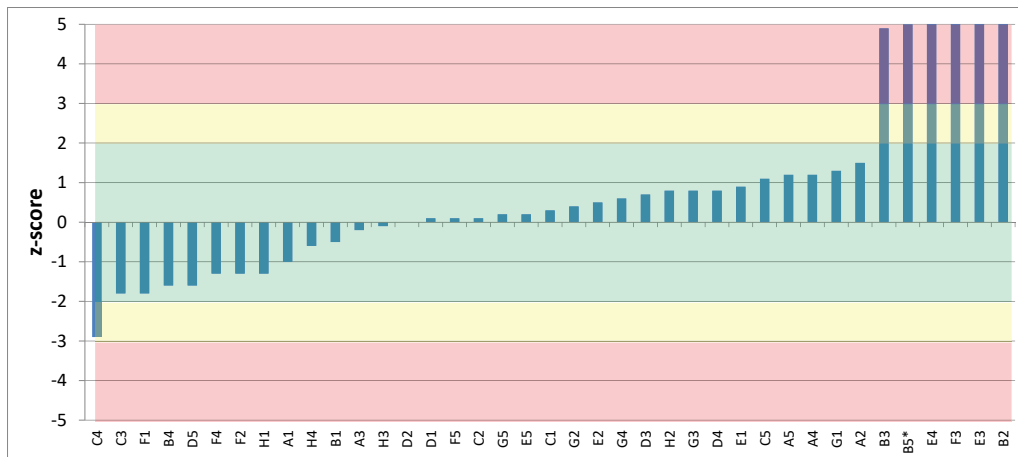

Figure 56. Is₂/ITSP

Table 79.

Tube		E	
Integral ratio		Isz/ItSP	
Lab Code	Average	Standard deviation	Z-score
C5	0,05592	0,00305	1.1
E3	3,81684	0,07423	727.1
A1	0,04471	0,00605	-1.0
H4	0,04708	0,00450	-0.6
G5	0,05094	0,00056	0.2
B1	0,04751	0,00129	-0.5
D1	0,05049	0,00157	0.1
C3	0,04092	0,00309	-1.8
B2	4,34548	0,09039	829.1
F4	0,04360	0,00088	-1.3
D3	0,05382	0,00205	0.7
G1	0,05678	0,00383	1.3
E1	0,05450	0,00195	0.9
E5	0,05112	0,00228	0.2
B3	0,07532	0,00204	4.9
A5	0,05655	0,00094	1.2
A4	0,05636	0,00095	1.2
H2	0,05434	0,00147	0.8
B4	0,04179	0,00407	-1.6
F1	0,04083	0,00203	-1.8
G3	0,05404	0,00104	0.8
D5	0,04160	0,00219	-1.6
F2	0,04326	0,00088	-1.3
C1	0,05151	0,00098	0.3
E2	0,05242	0,00126	0.5
A3	0,04920	0,00227	-0.2
F5	0,05082	0,00041	0.1
F3	0,31726	0,01538	51.6
H3	0,04951	0,00562	-0.1
G2	0,05194	0,00048	0.4
D4	0,05448	0,00098	0.8
G4	0,05334	0,00308	0.6
C2	0,05072	0,00185	0.1
C4	0,03509	0,00692	-2.9
H1	0,04322	0,00072	-1.3
A2	0,05773	0,01256	1.5
E4	0,08212	0,01091	6.2
D2	0,05020	0,00286	0.0
B5*	0,07600	0,00548	5.0

Table 80.

Tube E	
Is₃/I_{TSP}	
Total number of data sets	39
Outliers	9
Number of data sets considered for statistics	30
Degrees of freedom	29
Average	0.40371
Interlaboratory standard deviation	0.07357
CV%	18.2
Minimum	0.19400
Maximum	0.58610
Range	0.39210
Median	0.40963
Repeatability variance	0.0001945648
Interlaboratory variance	0.0053736886
Reproducibility variance	0.0055682534
Confidence interval	0.04632
Minimum confidence limit	0.38055
Maximum confidence limit	0.42687
Reproducibility limit	0.21551

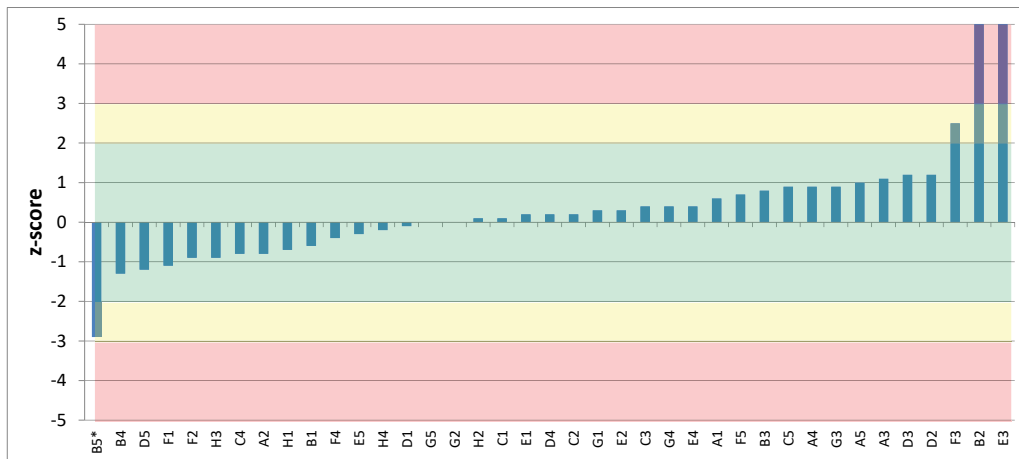

Figure 57. Is₃/I_{TSP}

Table 81.

Tube		E	
Integral ratio		Is3/ItSP	
Lab Code	Average	Standard deviation	Z-score
C5	0,4693	0,0520	0.9
E3	37,5849	1,9213	505.4
A1	0,4498	0,0196	0.6
H4	0,3917	0,0352	-0.2
G5	0,4047	0,0111	0.0
B1	0,3596	0,0176	-0.6
D1	0,3971	0,0099	-0.1
C3	0,4305	0,0726	0.4
B2	36,1929	0,3592	486.5
F4	0,3757	0,0022	-0.4
D3	0,4922	0,0118	1.2
G1	0,4277	0,0518	0.3
E1	0,4170	0,0136	0.2
E5	0,3782	0,0161	-0.3
B3	0,4595	0,0088	0.8
A5	0,4776	0,0082	1.0
A4	0,4683	0,0083	0.9
H2	0,4109	0,0076	0.1
B4	0,3115	0,0172	-1.3
F1	0,3239	0,0086	-1.1
G3	0,4676	0,0228	0.9
D5	0,3148	0,0184	-1.2
F2	0,3352	0,0049	-0.9
C1	0,4084	0,0059	0.1
E2	0,4283	0,0123	0.3
A3	0,4859	0,0180	1.1
F5	0,4534	0,0272	0.7
F3	0,5861	0,0107	2.5
H3	0,3411	0,0093	-0.9
G2	0,4071	0,0066	0.0
D4	0,4173	0,0060	0.2
G4	0,4324	0,0141	0.4
C2	0,4217	0,0118	0.2
C4	0,3418	0,0201	-0.8
H1	0,3502	0,0074	-0.7
A2	0,3456	0,1150	-0.8
E4	0,4368	0,0773	0.4
D2	0,4922	0,0340	1.2
B5*	0,1940	0,0219	-2.9

Table 82.

Tube E	
Is₄/I_{TSP}	
Total number of data sets	39
Outliers	7
Number of data sets considered for statistics	32
Degrees of freedom	31
Average	0.60666
Interlaboratory standard deviation	0.06122
CV%	10.1
Minimum	0.49440
Maximum	0.73900
Range	0.24460
Median	0.60422
Repeatability variance	0.00049
Interlaboratory variance	0.0036503348
Reproducibility variance	0.0041376130
Confidence interval	0.0386615144
Minimum confidence limit	0.58733
Maximum confidence limit	0.62599
Reproducibility limit	0.18529

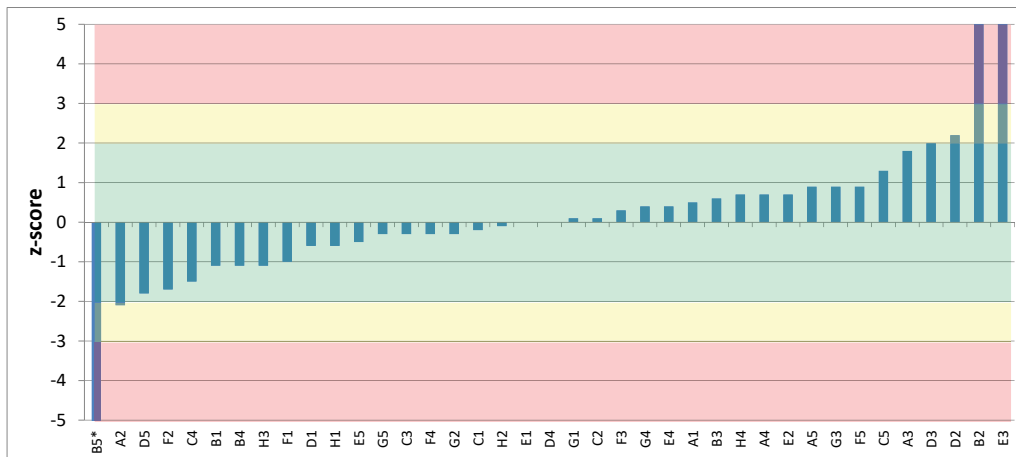

Figure 58. Is₄/I_{TSP}

Table 83.

Tube	E		
Integral ratio	Is4/ItSP		
Lab Code	Average	Standard deviation	Z-score
C5	0,6837	0,0689	1.3
E3	56,5253	2,4959	913.4
A1	0,6397	0,0442	0.5
H4	0,6468	0,0604	0.7
G5	0,5913	0,0212	-0.3
B1	0,5372	0,0312	-1.1
D1	0,5696	0,0144	-0.6
C3	0,5905	0,0390	-0.3
B2	55,5877	0,7349	898.1
F4	0,5889	0,0110	-0.3
D3	0,7266	0,0137	2.0
G1	0,6144	0,0748	0.1
E1	0,6072	0,0157	0.0
E5	0,5737	0,0222	-0.5
B3	0,6422	0,0110	0.6
A5	0,6644	0,0108	0.9
A4	0,6500	0,0109	0.7
H2	0,6030	0,0182	-0.1
B4	0,5408	0,0285	-1.1
F1	0,5476	0,0175	-1.0
G3	0,6633	0,0273	0.9
D5	0,4944	0,0313	-1.8
F2	0,5034	0,0065	-1.7
C1	0,5959	0,0063	-0.2
E2	0,6500	0,0164	0.7
A3	0,7190	0,0056	1.8
F5	0,6602	0,0299	0.9
F3	0,6225	0,0292	0.3
H3	0,5370	0,0158	-1.1
G2	0,5903	0,0137	-0.3
D4	0,6055	0,0074	0.0
G4	0,6339	0,0187	0.4
C2	0,6101	0,0108	0.1
C4	0,5142	0,0292	-1.5
H1	0,5686	0,0114	-0.6
A2	0,4808	0,2023	-2.1
E4	0,6332	0,0103	0.4
D2	0,7390	0,0415	2.2
B5*	0,2180	0,0259	-6.3

Table 84.

Tube E	
I_{ss}/I_{TSP}	
Total number of data sets	39
Outliers	10
Number of data sets considered for statistics	29
Degrees of freedom	28
Average	0.70581
Interlaboratory standard deviation	0.19066
CV%	27.0
Minimum	0.21200
Maximum	1.03900
Range	0.82700
Median	0.74115
Repeatability variance	0.0018193290
Interlaboratory variance	0.0359869705
Reproducibility variance	0.0378062995
Confidence interval	0.12276
Minimum confidence limit	0.64443
Maximum confidence limit	0.76719
Reproducibility limit	0.56238

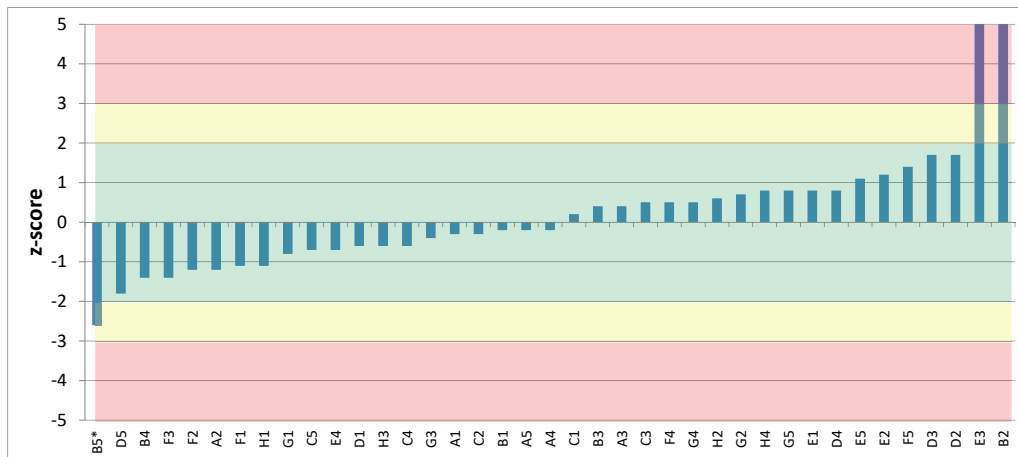

Figure 59. I_{ss}/I_{TSP}

Table 85.

Tube		E	
Integral ratio		Iss/I _{TSP}	
Lab Code	Average	Standard deviation	Z-score
C5	0,5818	0,1354	-0.7
E3	71,6558	3,7509	372.1
A1	0,6418	0,2152	-0.3
H4	0,8648	0,0267	0.8
G5	0,8554	0,0488	0.8
B1	0,6666	0,0261	-0.2
D1	0,5941	0,0129	-0.6
C3	0,8093	0,0340	0.5
B2	72,8975	0,6605	378.6
F4	0,8039	0,0051	0.5
D3	1,0289	0,0829	1.7
G1	0,5532	0,1681	-0.8
E1	0,8671	0,0106	0.8
E5	0,9076	0,1201	1.1
B3	0,7853	0,0605	0.4
A5	0,6681	0,0076	-0.2
A4	0,6627	0,0066	-0.2
H2	0,8156	0,0719	0.6
B4	0,4417	0,0330	-1.4
F1	0,4970	0,0209	-1.1
G3	0,6289	0,0651	-0.4
D5	0,3538	0,1057	-1.8
F2	0,4846	0,0672	-1.2
C1	0,7411	0,0205	0.2
E2	0,9317	0,0375	1.2
A3	0,7839	0,0615	0.4
F5	0,9808	0,2776	1.4
F3	0,4340	0,0268	-1.4
H3	0,5998	0,0126	-0.6
G2	0,8486	0,0844	0.7
D4	0,8678	0,0111	0.8
G4	0,8036	0,0375	0.5
C2	0,6558	0,0427	-0.3
C4	0,5961	0,1391	-0.6
H1	0,5031	0,0110	-1.1
A2	0,4835	0,2325	-1.2
E4	0,5740	0,0537	-0.7
D2	1,0390	0,0344	1.7
B5*	0,2120	0,0179	-2.6

Table 86.

Tube E	
Is6/ITSP	
Total number of data sets	39
Outliers	21
Number of data sets considered for statistics	18
Degrees of freedom	17
Average	0.29557
Interlaboratory standard deviation	0.04203
CV%	14.2
Minimum	0.21228
Maximum	0.33187
Range	0.11959
Median	0.31505
Repeatability variance	0.0000569311
Interlaboratory variance	0.0017551342
Reproducibility variance	0.0018120653
Confidence interval	0.03492
Minimum confidence limit	0.27812
Maximum confidence limit	0.31303
Reproducibility limit	0.12648

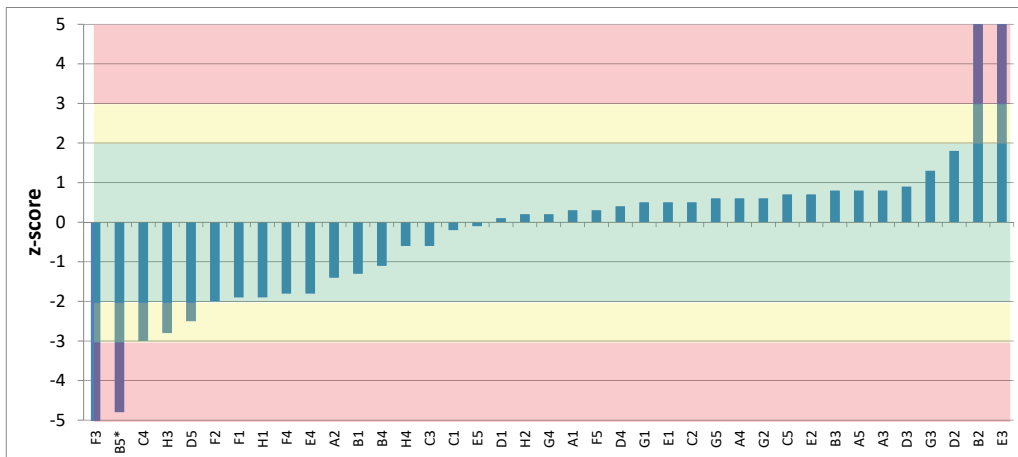

Figure 60. Is6/ITSP

Table 87.

Tube		E	
Integral ratio		I _{se} /I _{rsp}	
Lab Code	Average	Standard deviation	Z-score
C5	0,32424	0,02044	0.7
E3	26,79346	0,33025	630.5
A1	0,30784	0,04787	0.3
H4	0,27018	0,02516	-0.6
G5	0,31900	0,01285	0.6
B1	0,24278	0,01047	-1.3
D1	0,29795	0,00095	0.1
C3	0,27194	0,02250	-0.6
B2	22,03088	0,84042	517.1
F4	0,21978	0,00322	-1.8
D3	0,33187	0,00671	0.9
G1	0,31814	0,01396	0.5
E1	0,31724	0,00817	0.5
E5	0,29310	0,03378	-0.1
B3	0,33096	0,02587	0.8
A5	0,33044	0,00244	0.8
A4	0,32269	0,00265	0.6
H2	0,30582	0,01717	0.2
B4	0,25104	0,03068	-1.1
F1	0,21635	0,02183	-1.9
G3	0,35045	0,03367	1.3
D5	0,19260	0,00456	-2.5
F2	0,21228	0,00322	-2.0
C1	0,28676	0,00561	-0.2
E2	0,32462	0,01047	0.7
A3	0,33104	0,00515	0.8
F5	0,30982	0,00530	0.3
F3	0,04780	0,00066	-5.9
H3	0,17729	0,00573	-2.8
G2	0,32104	0,00805	0.6
D4	0,31286	0,00235	0.4
G4	0,30598	0,01190	0.2
C2	0,31760	0,04435	0.5
C4	0,16787	0,00554	-3.0
H1	0,21606	0,00115	-1.9
A2	0,23658	0,10561	-1.4
E4	0,21824	0,04805	-1.8
D2	0,37080	0,01788	1.8
B5*	0,09400	0,00548	-4.8

Table 88.

Tube E	
Is₇/I_{TSP}	
Total number of data sets	39
Outliers	7
Number of data sets considered for statistics	32
Degrees of freedom	31
Average	2.30293
Interlaboratory standard deviation	0.17705
CV%	7.7
Minimum	1.90117
Maximum	2.62695
Range	0.72578
Median	2.31319
Repeatability variance	0.0029520463
Interlaboratory variance	0.0307565937
Reproducibility variance	0.0337086400
Confidence interval	0.11035
Minimum confidence limit	2.24776
Maximum confidence limit	2.35811
Reproducibility limit	0.52888

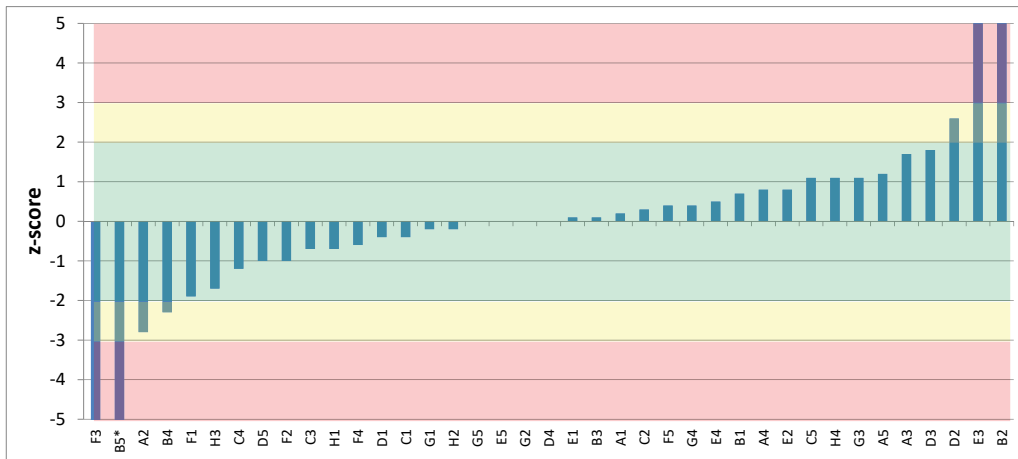

Figure 61. Is₇/I_{TSP}

Table 89.

Tube		E	
Integral ratio		I _{S7} /I _{TSP}	
Lab Code	Average	Standard deviation	Z-score
C5	2,50002	0,08034	1.1
E3	213,12496	8,42755	1190.7
A1	2,34267	0,03496	0.2
H4	2,49708	0,10223	1.1
G5	2,30964	0,04611	0.0
B1	2,42905	0,07195	0.7
D1	2,22469	0,01486	-0.4
C3	2,17494	0,02186	-0.7
B2	214,94180	0,85046	1201.0
F4	2,19640	0,00816	-0.6
D3	2,62695	0,04461	1.8
G1	2,26372	0,08868	-0.2
E1	2,31660	0,01513	0.1
E5	2,30464	0,11949	0.0
B3	2,32300	0,05859	0.1
A5	2,51555	0,01939	1.2
A4	2,45209	0,02112	0.8
H2	2,27286	0,02033	-0.2
B4	1,90117	0,09615	-2.3
F1	1,96692	0,06212	-1.9
G3	2,49147	0,09895	1.1
D5	2,11920	0,01521	-1.0
F2	2,11914	0,01195	-1.0
C1	2,22691	0,01493	-0.4
E2	2,44070	0,05259	0.8
A3	2,61276	0,05324	1.7
F5	2,36794	0,03915	0.4
F3	0,03712	0,00088	-12.8
H3	2,00563	0,08031	-1.7
G2	2,30978	0,00966	0.0
D4	2,29838	0,01205	0.0
G4	2,36818	0,04627	0.4
C2	2,35222	0,06093	0.3
C4	2,08375	0,04345	-1.2
H1	2,18600	0,01205	-0.7
A2	1,81052	0,90743	-2.8
E4	2,39850	0,09122	0.5
D2	2,75980	0,14913	2.6
B5*	0,55400	0,04278	-9.9

2.6.12 Final comments

Results presented above indicate that the NMR experiment (1D ^1H NOESY) proposed for the fingerprinting of wheat and flour aqueous extracts is a robust experiment. In fact, the majority of the participants (more than 70 %) produced NMR spectra that can be considered “statistically equivalent”. Thus, the main goal of this interlaboratory comparison, the validation of the 1D ^1H NOESY experiment, was achieved along with the indication of the participants able to produce NMR spectra with the highest possible performances.

Since no previous report is available for a comparative evaluation of the results, at this stage it is advisable to highlight some possible critical points taking into account z-scores and CV% values collected in this ILC.

Abnormal z-score values (hundreds or thousands) were obtained very frequently by three participants (E3, B2 and F3). Such participants should seriously investigate on the reasons for such anomalous results. Other participants obtained occasionally unsatisfactory z-scores. Since they obtained both satisfactory and unsatisfactory performances for signals recorded for the same NMR tube, a possible cause for such results might derive either from incorrect phase correction or incorrect baseline correction. It is not excluded a combination of errors in the two correction procedures.

CV% represent the values to be considered as starting point to evaluate the precision of the method in future ILC. CV% values do not depend on the magnitude of $I_{\text{signal}}/I_{\text{TSP}}$ ratio. The highest CV% values (25.5% – 27.0%) found for all the NMR tubes B-E are related to $I_{\text{S5}}/I_{\text{TSP}}$. This can be safely explained with the influence of the pre-saturation radiation acting in close proximity to the frequency of S5. Little differences in terms of soft pulse calibration, unavoidable in an ILC, can markedly affect the reproducibility of the $I_{\text{S5}}/I_{\text{TSP}}$ ratio. CV% higher than 10% were obtained also for $I_{\text{S2}}/I_{\text{TSP}}$, $I_{\text{S3}}/I_{\text{TSP}}$ and $I_{\text{S6}}/I_{\text{TSP}}$. In order to give a plausible explanation for such values it should be investigated the exact composition of the mixture with the aim to ascertain the response of the nuclei to the experienced excitation/relaxation conditions during spectrum acquisition. Indeed, as previously claimed (Gallo et al., 2015 a) the nuclei response depends on several factors including (i) hard excitation pulse which must be uniform throughout all the spectral width; (ii) proximity of the signals to the offsets; (iii) recycle delay, which must be long enough to allow for complete

magnetization recovery of all nuclei; (iv) energy exchange effects (NOE, spin diffusion, etc.) introduced by soft pulses.

In conclusion, future ILC using the same NMR experiment should be organized to confirm the results published and to pave the way to validation of NMR experiment on different matrixes.

CHAPTER VII

2.7 Validation of NMR fingerprinting methods: effects of processing on measure reproducibility and laboratory performance assessment

It was aimed to assess the performances of the NMR laboratories in the quantification of analytes. A five-component model mixture was considered and the calibration line approach was used for quantification. (Gallo et al, 2013)

Among the quantification approaches available for NMR spectroscopy (Bharti and Roy, 2012), the calibration line method was chosen because of its general applicability in analytical chemistry and because it has the advantage to nullify the effects of nuclei relaxation on quantitative accuracy, provided that all the acquisition parameters are kept constant for standard and test solutions (Bharti and Roy, 2012). Moreover, it minimized systematic errors deriving from hardware features or from the set of acquisition parameters.

Re-elaboration of the data produced during the first ILC allowed for identification of a theoretical line to be taken as reference in performance assessment. Thus, the performance assessment was carried out by means of the parameter (z-score) usually considered as performance index in single component quantifications as well as by means of a new parameter, named Qp-score, better suited for performance assessment in multi-component and fingerprinting analyses. In addition, a third index (NR), specific for each NMR signal, was introduced to gain insights into the possible effects of the acquisition parameters on signal intensities (Gallo et al., 2015 a). NR represents an index of the specific response of the various nuclei submitted to a definite NMR experiment. Qp-score and NR are parameters accounting for statistical equivalence of NMR spectra of model mixtures. In order to ascertain statistical equivalence of NMR spectra of real samples, a second interlaboratory comparison was organized. It consisted in the analysis of wheat and flours aqueous extracts (4 samples). 780 NMR spectra were produced by 32 participants using 39 different NMR spectrometers. Seven NMR signals were selected for elaboration by univariate internationally agreed statistics typically applied in performance assessment of ILC participants (Gallo et al., 2015 b).

Some unsuccessful performances of a limited number of participants prompted us to reconsider spectra processing. Thus, the 780 NMR spectra were submitted to 3 additional processing sessions differing from the first session (Gallo et al., 2015 b).for number of operators, processing procedure, software and integration mode.

The aim of this interlaboratory comparison is the evaluation of the effects of processing on measure reproducibility and laboratory performance assessment of a fingerprinting NMR method for classification of wheat and flours.

Seven NMR signals were selected for elaboration by univariate internationally agreed statistics typically applied in performance assessment of ILC participants (ISO 13528:2005). NMR data were generated submitting the 780 1D ¹H-NOESY spectra (4 NMR samples × 5 replicates × 39 NMR spectrometers) to 4 processing sessions differing for number of operators, processing procedure, software and integration mode. In the following table the details of the four processing sessions are listed.

Table 90.

Session	Number of operators	Processing procedure	Software	Integration mode
ILC1	many	phase and baseline correction according to operator expertise	no limitation	no limitation
ILC2	one	manual phase correction and automatic baseline correction	AMIX	integral
ILC3	one (different from session ILC2)	manual phase correction and automatic baseline correction	Mestre Nova	sum
ILC4	one (the same as in session ILC3)	manual phase correction and automatic baseline correction	Mestre Nova	peak

Common steps of the sessions 2-4 consisted in Fourier transformation applying exponential multiplication function with a line broadening of 0.1 Hz, manual phase and automatic baseline correction.

Signal integrals were calculated considering the ranges listed in table 91.

Table 91.

Signal label	Integration range(ppm)	
	Left limit	Right limit
TSP	0.50	-0.50
S1	9.50	9.40
S2	7.56	7.48
S3	5.46	5.32
S4	5.28	5.16
S5	4.68	4.60
S6	4.12	4.07
S7	3.33	3.14

Signals S1-7 were selected with the aim to appreciate the reproducibility limits of very weak signals (S1 and S2), of medium intensity signals (S3 and S6), of a very intense signal (S7) and of signals (S4 and S5) with the chemical shift in close proximity to pre-saturation frequency (ca. 4.70 ppm). Results are subdivided in four sections, one per NMR tube. Each section is subdivided into seven subsections, one per signal ratio. Each subsection contains a summary table and a z-score table.

The summary tables list the following parameters: Total number of data sets, Outliers, Number of data sets considered for statistics, Degrees of freedom, Average, Interlaboratory standard deviation, CV%, Minimum, Maximum, Range, Median, Repeatability variance, Interlaboratory variance, Reproducibility variance, Confidence interval, Minimum confidence limit, Maximum confidence limit, Reproducibility limit.

The z-score tables show the participant performances assessed by z-score. Values highlighted in cyan were identified as outliers according to Cochran test while those highlighted in violet were identified as outliers according to Huber test. Participant marked with * submitted non compliant signal ratio in terms of number of decimal places (2 decimal places instead of the expected 4). This resulted in null standard deviations in many cases. However, these non compliant data were always considered as outliers, independently on the outcome of the Cochran and Huber tests, and were included in the general data elaboration.

2.7.1 Tube B

Table 92.

Tube B				
	Is₁/I_{TSP}			
	ILC1	ILC2	ILC3	ILC4
Total number of data sets	39	39	39	39
Outliers	9	11	9	5
N. of data sets consid. for statistics	30	28	30	34
Degrees of freedom	29	27	29	33
Average	0.02626	0.02747	0.02515	0.03019
Interlaboratory standard deviation	0.00212	0.00096	0.00116	0.00122
CV%	8.1	3.5	4.6	4.1
Minimum	0.02207	0.02535	0.02288	0.02780
Maximum	0.03070	0.02947	0.02764	0.03254
Range	0.00862	0.00412	0.00476	0.00474
Median	0.02610	0.02765	0.02518	0.03033
Repeatability variance	0.0000045901	0.0000015257	0.0000023970	0.0000020316
Interlaboratory variance	0.0000035952	0.0000006252	0.0000008630	0.0000010900
Reproducibility variance	0.0000081853	0.0000021509	0.0000032600	0.0000031216
Confidence interval	0.00178	0.00095	0.00112	0.00103
Minimum confidence limit	0.02537	0.02699	0.02459	0.02967
Maximum confidence limit	0.02714	0.02794	0.02571	0.03070
Reproducibility limit	0.00826	0.00425	0.00521	0.00508

Table 93.

Tube	B							
Integral ratio	IsI/ITSP							
Lab Code	ILC1 Average	ILC1 Z-score	ILC2 Average	ILC2 Z-score	ILC3 Average	ILC3 Z-score	ILC4 Average	ILC4 Z-score
C5	0,02420	-1.0	0,02516	-2.4	0,02498	-0.1	0,03174	1.3
E3	2,63706	1228.9	0,02604	-1.5	0,02328	-1.6	0,02986	-0.3
A1	0,02383	-1.1	0,02493	-2.6	0,02172	-3.0	0,03194	1.4
H4	0,03070	2.1	0,02928	1.9	0,02526	0.1	0,03042	0.2
G5	0,02520	-0.5	0,02714	-0.3	0,02580	0.6	0,02822	-1.6
B1	0,02751	0.6	0,02742	-0.1	0,02498	-0.1	0,02862	-1.3
D1	0,02471	-0.7	0,02711	-0.4	0,02398	-1.0	0,02970	-0.4
C3	0,02409	-1.0	0,02415	-3.4	0,02246	-2.3	0,03036	0.1
B2	2,70651	1261.6	0,02706	-0.4	0,02532	0.1	0,03102	0.7
F4	0,02753	0.6	0,02535	-2.2	0,02498	-0.1	0,02834	-1.5
D3	0,02493	-0.6	0,02551	-2.0	0,02722	1.8	0,02956	-0.5
G1	0,02312	-1.5	0,02772	0.3	0,02504	-0.1	0,03252	1.9
E1	0,02680	0.3	0,02771	0.3	0,02612	0.8	0,03036	0.1
E5	0,02558	-0.3	0,02770	0.2	0,02470	-0.4	0,02868	-1.2
B3	0,05428	13.2	0,02455	-3.0	0,02394	-1.0	0,03254	1.9
A5	0,02207	-2.0	0,02765	0.2	0,02764	2.2	0,03090	0.6
A4	0,02301	-1.5	0,02765	0.2	0,02764	2.2	0,03090	0.6
H2	0,02924	1.4	0,02813	0.7	0,02538	0.2	0,02982	-0.3
B4	0,02551	-0.3	0,02742	-0.0	0,02448	-0.6	0,02924	-0.8
F1	0,02458	-0.8	0,02776	0.3	0,02338	-1.5	0,03062	0.4
G3	0,02425	-0.9	0,02947	2.1	0,02576	0.5	0,03274	2.1
D5	0,02860	1.1	0,02671	-0.8	0,02460	-0.5	0,03066	0.4
F2	0,02698	0.3	0,02779	0.3	0,02636	1.0	0,03024	0.0
C1	0,02820	0.9	0,02766	0.2	0,02528	0.1	0,03218	1.6
E2	0,02616	0.0	0,02697	-0.5	0,02564	0.4	0,03018	-0.0
A3	0,02938	1.5	0,02703	-0.4	0,02522	0.1	0,02870	-1.2
F5	0,02628	0.0	0,02778	0.3	0,02512	-0.0	0,03030	0.1
F3	2,54874	1187.4	0,02818	0.7	0,02524	0.1	0,02988	-0.3
H3	0,04214	7.5	0,02679	-0.7	0,02774	2.2	0,03216	1.6
G2	0,02506	-0.6	0,02738	-0.1	0,02546	0.3	0,02892	-1.0
D4	0,02604	-0.1	0,02800	0.6	0,02482	-0.3	0,02780	-2.0
G4	0,02542	-0.4	0,02574	-1.8	0,02288	-2.0	0,03104	0.7
C2	0,02682	0.3	0,02880	1.4	0,02354	-1.4	0,03128	0.9
C4	0,02919	1.4	0,02503	-2.5	0,02201	-2.7	0,02652	-3.0
H1	0,02852	1.1	0,02701	-0.5	0,02220	-2.5	0,03080	0.5
A2	0,02883	1.2	0,02758	0.1	0,02148	-3.2	0,03188	1.4
E4	0,07580	23.3	0,02725	-0.2	0,02848	2.9	0,03096	0.6
D2	0,02800	0.8	0,02393	-3.7	0,02562	0.4	0,03070	0.4
B5*	0,09000	30.0	0,02977	2.4	0,02826	2.7	0,02878	-1.2

Table 94.

Tube B				
	Is2/ITS_P			
	ILC1	ILC2	ILC3	ILC4
Total number of data sets	39	39	39	39
Outliers	7	2	6	7
N. of data sets consid. for statistics	32	37	33	32
Degrees of freedom	31	36	32	31
Average	0.03765	0.04297	0.03721	0.03224
Interlaboratory standard deviation	0.00451	0.00249	0.00269	0.00099
CV%	12.0	5.8	7.2	3.1
Minimum	0.02850	0.03941	0.02964	0.03060
Maximum	0.04382	0.04937	0.04028	0.03470
Range	0.01532	0.00997	0.01064	0.00410
Median	0.03926	0.04260	0.03754	0.03229
Repeatability variance	0.0000094645	0.0000072469	0.0000037799	0.0000024542
Interlaboratory variance	0.0000184435	0.0000047709	0.0000064842	0.0000004807
Reproducibility variance	0.0000279080	0.0000120178	0.0000102641	0.0000029349
Confidence interval	0.00318	0.00194	0.00190	0.00103
Minimum confidence limit	0.03607	0.04200	0.03626	0.03173
Maximum confidence limit	0.03924	0.04394	0.03815	0.03275
Reproducibility limit	0.01522	0.00993	0.00922	0.00493

Table 95.

Tube	B							
Integral ratio	Is2/ItSP							
Lab-Code	ILC1 Average	ILC1 Z-score	ILC2 Average	ILC2 Z-score	ILC3 Average	ILC3 Z-score	ILC4 Average	ILC4 Z-score
C5	0,03928	0.4	0,03968	-1.3	0,03644	-0.3	0,03430	2.1
E3	2,94878	645.5	0,04345	0.2	0,03468	-0.9	0,03234	0.1
A1	0,04023	0.6	0,04416	0.5	0,02964	-2.8	0,03208	-0.2
H4	0,03206	-1.2	0,04937	2.6	0,03986	1.0	0,03248	0.2
G5	0,03880	0.3	0,04100	-0.8	0,03872	0.6	0,03132	-0.9
B1	0,03277	-1.1	0,04058	-1.0	0,03754	0.1	0,03154	-0.7
D1	0,04134	0.8	0,04299	0.0	0,03648	-0.3	0,03234	0.1
C3	0,03051	-1.6	0,03941	-1.4	0,03474	-0.9	0,03084	-1.4
B2	3,36674	738.2	0,04224	-0.3	0,03734	0.0	0,03224	0.0
F4	0,03335	-1.0	0,04063	-0.9	0,03964	0.9	0,03060	-1.7
D3	0,04133	0.8	0,03960	-1.4	0,03964	0.9	0,02998	-2.3
G1	0,03826	0.1	0,04260	-0.1	0,03800	0.3	0,03268	0.4
E1	0,04150	0.9	0,04237	-0.2	0,03988	1.0	0,03220	-0.0
E5	0,04070	0.7	0,04287	-0.0	0,03970	0.9	0,03272	0.5
B3	0,06382	5.8	0,03972	-1.3	0,03932	0.8	0,03244	0.2
A5	0,04164	0.9	0,04510	0.9	0,03142	-2.2	0,03114	-1.1
A4	0,04190	0.9	0,04510	0.9	0,03142	-2.2	0,03114	-1.1
H2	0,04382	1.4	0,04322	0.1	0,03906	0.7	0,03198	-0.3
B4	0,02850	-2.0	0,04021	-1.1	0,03678	-0.2	0,03168	-0.6
F1	0,02488	-2.8	0,04385	0.4	0,03846	0.5	0,03282	0.6
G3	0,04165	0.9	0,04542	1.0	0,03834	0.4	0,03480	2.6
D5	0,03040	-1.6	0,04204	-0.4	0,03550	-0.6	0,03252	0.3
F2	0,03170	-1.3	0,04199	-0.4	0,03982	1.0	0,03146	-0.8
C1	0,04121	0.8	0,04161	-0.5	0,03722	0.0	0,03316	0.9
E2	0,04018	0.6	0,04287	-0.0	0,04028	1.1	0,03416	1.9
A3	0,03552	-0.5	0,04155	-0.6	0,03458	-1.0	0,02938	-2.9
F5	0,03862	0.2	0,04406	0.4	0,03952	0.9	0,03280	0.6
F3	0,30588	59.5	0,04254	-0.2	0,03648	-0.3	0,03092	-1.3
H3	0,03276	-1.1	0,03410	-3.6	0,01976	-6.5	0,03036	-1.9
G2	0,03924	0.4	0,04164	-0.5	0,03938	0.8	0,03222	-0.0
D4	0,04224	1.0	0,04357	0.2	0,03982	1.0	0,03316	0.9
G4	0,04072	0.7	0,04178	-0.5	0,03664	-0.2	0,03724	5.1
C2	0,03972	0.5	0,04590	1.2	0,03700	-0.1	0,03470	2.5
C4	0,03431	-0.7	0,03235	-4.3	0,02729	-3.7	0,02816	-4.1
H1	0,03002	-1.7	0,04675	1.5	0,03456	-1.0	0,03274	0.5
A2	0,04301	1.2	0,04490	0.8	0,03510	-0.8	0,03202	-0.2
E4	0,07660	8.6	0,03970	-1.3	0,03570	-0.6	0,03292	0.7
D2	0,03760	0.0	0,04661	1.5	0,03890	0.6	0,03238	0.1
B5*	0,07600	8.5	0,04888	2.4	0,03990	1.0	0,03080	-1.5

Table 96

Tube B				
	Is ₃ /I _{TS} P			
	ILC1	ILC2	ILC3	ILC4
Total number of data sets	39	39	39	39
Outliers	9	9	10	14
N. of data sets consid. for statistics	30	30	29	25
Degrees of freedom	29	29	28	24
Average	0.56499	0.59473	0.58901	0.43104
Interlaboratory standard deviation	0.08910	0.03080	0.02466	0.01643
CV%	15.8	5.2	4.2	3.8
Minimum	0.38344	0.53438	0.53840	0.40300
Maximum	0.74550	0.67124	0.64380	0.46420
Range	0.36206	0.13686	0.10540	0.06120
Median	0.58661	0.59016	0.59400	0.42960
Repeatability variance	0.0005281285	0.0004431654	0.0004844517	0.0002233320
Interlaboratory variance	0.0078329502	0.0008600774	0.0005110923	0.0002254303
Reproducibility variance	0.0083610787	0.0013032428	0.0009955440	0.0004487623
Confidence interval	0.05676	0.02241	0.01992	0.01449
Minimum confidence limit	0.53661	0.58353	0.57905	0.42380
Maximum confidence limit	0.59337	0.60594	0.59897	0.43828
Reproducibility limit	0.26409	0.10426	0.09126	0.06170

Table 97.

Tube		B						
Integral ratio		Is3/ItSP						
Lab Code	ILC1 Average	ILC1 Z-score	ILC2 Average	ILC2 Z-score	ILC3 Average	ILC3 Z-score	ILC4 Average	ILC4 Z-score
C5	0,58550	0.2	0,57058	-0.8	0,61200	0.9	0,44380	0.8
E3	56,15026	623.9	0,66953	2.4	0,59420	0.2	0,45640	1.5
A1	0,63895	0.8	0,70202	3.5	0,63420	1.8	0,47480	2.7
H4	0,59156	0.3	0,62840	1.1	0,60540	0.7	0,45200	1.3
G5	0,57038	0.1	0,56862	-0.8	0,57260	-0.7	0,42520	-0.4
B1	0,48342	-0.9	0,54427	-1.6	0,54660	-1.7	0,41900	-0.7
D1	0,57900	0.2	0,58159	-0.4	0,56900	-0.8	0,42020	-0.7
C3	0,58684	0.2	0,58125	-0.4	0,57560	-0.5	0,45240	1.3
B2	49,61248	550.5	0,58982	-0.2	0,58740	-0.1	0,53540	6.4
F4	0,50294	-0.7	0,58559	-0.3	0,62780	1.6	0,40620	-1.5
D3	0,68432	1.3	0,50654	-2.9	0,67720	3.6	0,55480	7.5
G1	0,57188	0.1	0,55253	-1.4	0,55160	-1.5	0,41600	-0.9
E1	0,57974	0.2	0,58282	-0.4	0,58080	-0.3	0,43860	0.5
E5	0,59194	0.3	0,59663	0.1	0,60140	0.5	0,52920	6.0
B3	0,61740	0.6	0,56775	-0.9	0,60820	0.8	0,43680	0.4
A5	0,63925	0.8	0,61820	0.8	0,67840	3.6	0,42960	-0.1
A4	0,62461	0.7	0,61820	0.8	0,67840	3.6	0,42960	-0.1
H2	0,58678	0.2	0,59447	-0.0	0,58660	-0.1	0,46080	1.8
B4	0,40063	-1.8	0,53438	-2.0	0,53840	-2.1	0,41720	-0.8
F1	0,38344	-2.0	0,56914	-0.8	0,58340	-0.2	0,43080	-0.0
G3	0,63611	0.8	0,58684	-0.3	0,57080	-0.7	0,47700	2.8
D5	0,41740	-1.7	0,57140	-0.8	0,57980	-0.4	0,40480	-1.6
F2	0,46482	-1.1	0,55193	-1.4	0,55420	-1.4	0,41740	-0.8
C1	0,57040	0.1	0,58644	-0.3	0,58380	-0.2	0,48980	3.6
E2	0,63498	0.8	0,60949	0.5	0,61080	0.9	0,50180	4.3
A3	0,65132	1.0	0,59050	-0.1	0,64380	2.2	0,44720	1.0
F5	0,63720	0.8	0,60782	0.4	0,60880	0.8	0,47840	2.9
F3	0,74550	2.0	0,57855	-0.5	0,56120	-1.1	0,42160	-0.6
H3	0,44485	-1.3	0,67124	2.5	0,67860	3.6	0,42140	-0.6
G2	0,58762	0.3	0,58719	-0.2	0,59860	0.4	0,46020	1.8
D4	0,59956	0.4	0,59524	0.0	0,59400	0.2	0,46420	2.0
G4	0,59032	0.3	0,60716	0.4	0,60920	0.8	0,55240	7.4
C2	0,58644	0.2	0,60977	0.5	0,59640	0.3	0,44100	0.6
C4	0,44990	-1.3	0,59288	-0.1	0,64240	2.2	0,40300	-1.7
H1	0,48406	-0.9	0,63507	1.3	0,60220	0.5	0,43540	0.3
A2	0,57929	0.2	0,60148	0.2	0,59600	0.3	0,43320	0.1
E4	0,57964	0.2	0,58520	-0.3	0,79280	8.3	0,42760	-0.2
D2	0,67680	1.3	0,64451	1.6	0,67420	3.5	0,45160	1.3
B5*	0,20600	-4.0	0,73801	4.7	0,78900	8.1	0,48340	3.2

Table 98.

Tube B				
	Is4/ITS_P			
	ILC1	ILC2	ILC3	ILC4
Total number of data sets	39	39	39	39
Outliers	9	9	9	4
N. of data sets consid. for statistics	30	30	30	35
Degrees of freedom	29	29	29	34
Average	0.74968	0.75024	0.77381	0.73691
Interlaboratory standard deviation	0.06380	0.04568	0.05127	0.04257
CV%	8.5	6.1	6.6	5.8
Minimum	0.63460	0.65234	0.66820	0.65100
Maximum	0.88120	0.85816	0.87240	0.82140
Range	0.24660	0.20582	0.20420	0.17040
Median	0.74787	0.74953	0.76480	0.74120
Repeatability variance	0.0007467382	0.0009320490	0.0007301533	0.0009833800
Interlaboratory variance	0.0039213138	0.0019005943	0.0024822340	0.0016152730
Reproducibility variance	0.0046680520	0.0028326433	0.0032123873	0.0025986530
Confidence interval	0.04241	0.03304	0.03518	0.02930
Minimum confidence limit	0.72848	0.73372	0.75622	0.72226
Maximum confidence limit	0.77089	0.76676	0.79140	0.75156
Reproducibility limit	0.19732	0.15371	0.16369	0.14635

Table 99.

Tube		B						
Integral ratio			Is4/ITSP					
Lab Code	ILC1 Average	ILC1 Z-score	ILC2 Average	ILC2 Z-score	ILC3 Average	ILC3 Z-score	ILC4 Average	ILC4 Z-score
C5	0,76082	0.2	0,73849	-0.3	0,78800	0.3	0,74460	0.2
E3	74,60106	1157.5	0,85816	2.4	0,78620	0.2	0,76500	0.7
A1	0,82606	1.2	0,90049	3.3	0,83580	1.2	0,74740	0.2
H4	0,77758	0.4	0,79703	1.0	0,78540	0.2	0,76480	0.7
G5	0,72856	-0.3	0,72265	-0.6	0,72800	-0.9	0,71880	-0.4
B1	0,63661	-1.8	0,66375	-1.9	0,66820	-2.1	0,66980	-1.6
D1	0,73220	-0.3	0,72993	-0.4	0,72840	-0.9	0,69660	-0.9
C3	0,73824	-0.2	0,71677	-0.7	0,72280	-1.0	0,78540	1.1
B2	71,07150	1102.2	0,74889	-0.0	0,75420	-0.4	0,80580	1.6
F4	0,72725	-0.4	0,76964	0.4	0,80440	0.6	0,69560	-1.0
D3	0,87423	2.0	0,65234	-2.1	0,87020	1.9	0,77500	0.9
G1	0,73452	-0.2	0,69714	-1.2	0,70280	-1.4	0,71400	-0.5
E1	0,74530	-0.1	0,74605	-0.1	0,74900	-0.5	0,74640	0.2
E5	0,77260	0.4	0,77430	0.5	0,78160	0.2	0,78440	1.1
B3	0,77268	0.4	0,72077	-0.6	0,78720	0.3	0,74440	0.2
A5	0,78435	0.5	0,75381	0.1	0,84980	1.5	0,69260	-1.0
A4	0,76555	0.2	0,75381	0.1	0,84980	1.5	0,69260	-1.0
H2	0,75044	0.1	0,76052	0.2	0,75820	-0.3	0,75540	0.4
B4	0,68200	-1.1	0,70400	-1.0	0,72480	-1.0	0,73240	-0.1
F1	0,64234	-1.7	0,72205	-0.6	0,76460	-0.2	0,72000	-0.4
G3	0,80227	0.8	0,73428	-0.3	0,72880	-0.9	0,75920	0.5
D5	0,63460	-1.8	0,70463	-1.0	0,72460	-1.0	0,65100	-2.0
F2	0,64988	-1.6	0,67463	-1.7	0,67600	-1.9	0,66060	-1.8
C1	0,73822	-0.2	0,75903	0.2	0,76020	-0.3	0,80820	1.7
E2	0,82542	1.2	0,79087	0.9	0,79480	0.4	0,80480	1.6
A3	0,85248	1.6	0,75666	0.1	0,83180	1.1	0,74120	0.1
F5	0,83148	1.3	0,78458	0.8	0,79180	0.4	0,76500	0.7
F3	0,73830	-0.2	0,72386	-0.6	0,71440	-1.2	0,68200	-1.3
H3	0,67276	-1.2	0,88544	3.0	0,92340	2.9	0,70740	-0.7
G2	0,75104	0.0	0,75017	-0.0	0,76380	-0.2	0,75140	0.3
D4	0,75382	0.1	0,74888	-0.0	0,75140	-0.4	0,75880	0.5
G4	0,78080	0.5	0,80021	1.1	0,81060	0.7	0,84020	2.4
C2	0,75308	0.1	0,76931	0.4	0,76500	-0.2	0,73780	0.0
C4	0,67823	-1.1	0,80587	1.2	0,86702	1.8	0,70500	-0.7
H1	0,70638	-0.7	0,80504	1.2	0,78320	0.2	0,72700	-0.2
A2	0,72549	-0.4	0,74503	-0.1	0,74800	-0.5	0,72520	-0.3
E4	0,75268	0.0	0,76517	0.3	1,05040	5.4	0,77920	1.0
D2	0,88120	2.1	0,83426	1.8	0,87240	1.9	0,79800	1.4
B5*	0,21200	-8.4	0,94722	4.3	1,03040	5.0	0,82140	2.0

Table 100.

Tube B				
	Iss/I _{TSP}			
	ILC1	ILC2	ILC3	ILC4
Total number of data sets	39	39	39	39
Outliers	7	12	8	7
N. of data sets consid. for statistics	32	27	31	32
Degrees of freedom	31	26	30	31
Average	0.87843	0.92267	0.95450	0.97366
Interlaboratory standard deviation	0.22933	0.21340	0.21002	0.16977
CV%	26.1	23.1	22.0	17.4
Minimum	0.24200	0.44940	0.46320	0.70440
Maximum	1.29178	1.41337	1.34400	1.24200
Range	1.04978	0.96397	0.88080	0.53760
Median	0.91704	0.92069	0.93500	0.98620
Repeatability variance	0.0030903940	0.0043285964	0.0061518903	0.0028500469
Interlaboratory variance	0.0519751204	0.0446726602	0.0428787309	0.0282523505
Reproducibility variance	0.0550655144	0.0490012566	0.0490306212	0.0311023974
Confidence interval	0.14104	0.14570	0.13522	0.10600
Minimum confidence limit	0.80791	0.84982	0.88689	0.92066
Maximum confidence limit	0.94895	0.99552	1.02211	1.02666
Reproducibility limit	0.67597	0.64232	0.63866	0.50802

Table 101.

Tube		B						
Integral ratio			Iss/I _{TSP}					
Lab Code	ILC1 Average	ILC1 Z-score	ILC2 Average	ILC2 Z-score	ILC3 Average	ILC3 Z-score	ILC4 Average	ILC4 Z-score
C5	0,75868	-0.5	0,73501	-0.9	0,75560	-0.9	0,83860	-0.8
E3	94,67266	409.0	0,82586	-0.5	0,88140	-0.3	1,06800	0.6
A1	0,82893	-0.2	0,83696	-0.4	0,87860	-0.4	1,06480	0.5
H4	1,13888	1.1	1,09150	0.8	1,15000	0.9	1,18400	1.2
G5	1,03080	0.7	1,01647	0.4	1,02520	0.3	1,10380	0.8
B1	0,76397	-0.5	0,78415	-0.6	0,79460	-0.8	0,85980	-0.7
D1	0,74254	-0.6	0,73449	-0.9	0,74700	-1.0	0,79920	-1.0
C3	1,03014	0.7	1,16414	1.1	1,15100	0.9	1,22400	1.5
B2	94,37778	407.7	1,15788	1.1	1,18200	1.1	1,13600	1.0
F4	0,99082	0.5	0,96752	0.2	1,07600	0.6	1,06400	0.5
D3	1,29178	1.8	1,41337	2.3	1,34400	1.9	1,14740	1.0
G1	0,79098	-0.4	0,78149	-0.7	0,79180	-0.8	0,79280	-1.1
E1	1,04138	0.7	1,04029	0.6	1,04800	0.4	1,11200	0.8
E5	1,13014	1.1	1,12650	1.0	1,13800	0.9	1,17800	1.2
B3	0,94812	0.3	0,95552	0.2	0,88500	-0.3	1,05340	0.5
A5	0,81757	-0.3	0,75035	-0.8	0,83620	-0.6	0,85340	-0.7
A4	0,80571	-0.3	0,75035	-0.8	0,83620	-0.6	0,85340	-0.7
H2	0,99090	0.5	1,00347	0.4	1,01800	0.3	1,04900	0.4
B4	0,58894	-1.3	0,77983	-0.7	0,71120	-1.2	0,70440	-1.6
F1	0,61938	-1.1	0,97066	0.2	0,88880	-0.3	1,01060	0.2
G3	0,78292	-0.4	0,71678	-1.0	0,73740	-1.0	0,83160	-0.8
D5	0,49960	-1.7	0,44940	-2.2	0,46320	-2.3	0,53100	-2.6
F2	0,66808	-0.9	0,69734	-1.1	0,70020	-1.2	0,75900	-1.3
C1	0,91305	0.2	0,93367	0.1	0,93500	-0.1	1,05600	0.5
E2	1,11886	1.0	1,08294	0.8	1,08800	0.6	1,18600	1.3
A3	1,01142	0.6	0,90015	-0.1	0,90880	-0.2	0,89960	-0.4
F5	0,99292	0.5	0,95379	0.1	0,97760	0.1	0,96180	-0.1
F3	0,57704	-1.3	0,71076	-1.0	0,72560	-1.1	0,76760	-1.2
H3	0,64773	-1.0	0,97013	0.2	1,27400	1.5	0,74860	-1.3
G2	1,04676	0.7	1,04644	0.6	1,06200	0.5	1,11800	0.9
D4	1,10000	1.0	1,10706	0.9	1,12200	0.8	1,08760	0.7
G4	0,97188	0.4	0,92069	-0.0	0,95980	0.0	1,21600	1.4
C2	0,81168	-0.3	0,71266	-1.0	0,72740	-1.1	0,83320	-0.8
C4	0,66168	-0.9	1,58941	3.1	2,28560	6.3	0,70720	-1.6
H1	0,66416	-0.9	1,02136	0.5	1,07140	0.6	0,78920	-1.1
A2	0,76589	-0.5	0,75624	-0.8	0,76520	-0.9	0,82260	-0.9
E4	0,92102	0.2	0,96274	0.2	0,87940	-0.4	1,46800	2.9
D2	1,27440	1.7	1,21011	1.3	1,24000	1.4	1,22600	1.5
B5*	0,24200	-2.8	1,17105	1.2	1,30200	1.7	1,24200	1.6

Table 102.

Tube B				
	Is6/ITS_P			
	ILC1	ILC2	ILC3	ILC4
Total number of data sets	39	39	39	39
Outliers	16	14	11	0
N. of data sets consid. for statistics	23	25	28	0
Degrees of freedom	22	24	27	38
Average	0.29320	0.30370	0.30534	0.26232
Interlaboratory standard deviation	0.04059	0.00876	0.01401	0.02039
CV%	13.8	2.9	4.6	7.8
Minimum	0.20814	0.28575	0.27760	0.21400
Maximum	0.35960	0.32141	0.33600	0.30980
Range	0.15146	0.03566	0.05840	0.09580
Median	0.30812	0.30409	0.30410	0.26180
Repeatability variance	0.0001353657	0.0001893407	0.0002841929	0.0003220667
Interlaboratory variance	0.0016207838	0.0000388674	0.0001395610	0.0003512932
Reproducibility variance	0.0017561495	0.0002282081	0.0004237539	0.0006733599
Confidence interval	0.03006	0.01033	0.01330	0.01404
Minimum confidence limit	0.27818	0.29854	0.29869	0.25530
Maximum confidence limit	0.30823	0.30887	0.31200	0.26935
Reproducibility limit	0.12260	0.04400	0.05963	0.07422

Table 103

Tube		B						
Integral ratio			Is6/ItSP					
Lab Code	ILC1 Average	ILC1 Z-score	ILC2 Average	ILC2 Z-score	ILC3 Average	ILC3 Z-score	ILC4 Average	ILC4 Z-score
C5	0,31192	0.5	0,30266	-0.1	0,32800	1.6	0,26040	-0.1
E3	26,23820	639.1	0,29940	-0.5	0,28080	-1.8	0,28580	1.2
A1	0,32493	0.8	0,34426	4.6	0,33220	1.9	0,25060	-0.6
H4	0,24714	-1.1	0,31950	1.8	0,31960	1.0	0,27080	0.4
G5	0,30812	0.4	0,30710	0.4	0,31060	0.4	0,26600	0.2
B1	0,23131	-1.5	0,30554	0.2	0,30940	0.3	0,26680	0.2
D1	0,30844	0.4	0,31050	0.8	0,30420	-0.1	0,26360	0.1
C3	0,27992	-0.3	0,32188	2.1	0,31016	0.3	0,29120	1.4
B2	21,12176	513.1	0,30409	0.0	0,30440	-0.1	0,27000	0.4
F4	0,21456	-1.9	0,27480	-3.3	0,31840	0.9	0,23780	-1.2
D3	0,32841	0.9	0,31520	1.3	0,33600	2.2	0,28500	1.1
G1	0,33054	0.9	0,32716	2.7	0,33000	1.8	0,25100	-0.6
E1	0,30276	0.2	0,30516	0.2	0,30360	-0.1	0,26600	0.2
E5	0,30256	0.2	0,30445	0.1	0,30580	0.0	0,27460	0.6
B3	0,31604	0.6	0,31611	1.4	0,29840	-0.5	0,23840	-1.2
A5	0,31922	0.6	0,29554	-0.9	0,32620	1.5	0,24920	-0.6
A4	0,31153	0.5	0,29554	-0.9	0,32620	1.5	0,24920	-0.6
H2	0,29914	0.1	0,30361	-0.0	0,30080	-0.3	0,27300	0.5
B4	0,26178	-0.8	0,33812	3.9	0,31420	0.6	0,26000	-0.1
F1	0,12689	-4.1	0,31641	1.5	0,28400	-1.5	0,25800	-0.2
G3	0,33630	1.1	0,30777	0.5	0,30240	-0.2	0,28660	1.2
D5	0,19300	-2.5	0,29040	-1.5	0,29760	-0.6	0,23820	-1.2
F2	0,20814	-2.1	0,29969	-0.5	0,30400	-0.1	0,26100	-0.1
C1	0,28101	-0.3	0,28836	-1.8	0,28580	-1.4	0,29300	1.5
E2	0,31378	0.5	0,30120	-0.3	0,30220	-0.2	0,25800	-0.2
A3	0,33266	1.0	0,29910	-0.5	0,31500	0.7	0,23080	-1.5
F5	0,28338	-0.2	0,27245	-3.6	0,27760	-2.0	0,27760	0.7
F3	0,03328	-6.4	0,30130	-0.3	0,29480	-0.8	0,25380	-0.4
H3	0,18554	-2.7	0,24959	-6.2	0,29880	-0.5	0,21400	-2.4
G2	0,30756	0.4	0,30668	0.3	0,31380	0.6	0,28100	0.9
D4	0,31450	0.5	0,31283	1.0	0,31440	0.6	0,30980	2.3
G4	0,28282	-0.3	0,28575	-2.0	0,29240	-0.9	0,29980	1.8
C2	0,29770	0.1	0,30804	0.5	0,30460	-0.1	0,24480	-0.9
C4	0,19334	-2.5	0,20767	-11.0	0,35340	3.4	0,22940	-1.6
H1	0,23014	-1.6	0,30978	0.7	0,30300	-0.2	0,26560	0.2
A2	0,31132	0.4	0,32141	2.0	0,32200	1.2	0,26180	-0.0
E4	0,27576	-0.4	0,24653	-6.5	0,24820	-4.1	0,25200	-0.5
D2	0,35960	1.6	0,33901	4.0	0,35680	3.7	0,26260	0.0
B5*	0,08200	-5.2	0,34325	4.5	0,37320	4.8	0,24340	-0.9

Table 104.

Tube B				
	Is7/ITS_P			
	ILC1	ILC2	ILC3	ILC4
Total number of data sets	39	39	39	39
Outliers	12	9	12	7
N. of data sets consid. for statistics	27	30	27	32
Degrees of freedom	26	29	26	31
Average	2.52876	2.51172	2.57207	2.76106
Interlaboratory standard deviation	0.14126	0.05218	0.06468	0.12038
CV%	5.6	2.1	2.5	4.4
Minimum	2.24255	2.41327	2.46600	2.55200
Maximum	2.87510	2.60822	2.68800	3.01800
Range	0.63255	0.19495	0.22200	0.46600
Median	2.53270	2.51871	2.56000	2.77400
Repeatability variance	0.0019545571	0.0011333796	0.0018592593	0.0100868750
Interlaboratory variance	0.0195624862	0.0024961681	0.0038113732	0.0124742339
Reproducibility variance	0.0215170433	0.0036295477	0.0056706325	0.0225611089
Confidence interval	0.09655	0.03740	0.04956	0.09028
Minimum confidence limit	2.48049	2.49302	2.54729	2.71592
Maximum confidence limit	2.57703	2.53042	2.59686	2.80620
Reproducibility limit	0.42564	0.17400	0.21851	0.43268

Table 105.

Tube		B						
Integral ratio		Is7/I _{TSP}						
Lab Code	ILC1 Average	ILC1 Z-score	ILC2 Average	ILC2 Z-score	ILC3 Average	ILC3 Z-score	ILC4 Average	ILC4 Z-score
C5	2,64512	0.8	2,56257	1.0	2,64000	1.1	2,77600	0.1
E3	261,43446	1832.9	2,52167	0.2	2,57400	0.0	2,78600	0.2
A1	2,54622	0.1	2,64172	2.5	2,67200	1.5	2,81800	0.5
H4	2,63850	0.8	2,57469	1.2	2,68400	1.7	2,80400	0.4
G5	2,52180	0.0	2,47936	-0.6	2,49600	-1.2	2,69200	-0.6
B1	2,58845	0.4	2,48079	-0.6	2,50800	-1.0	2,91200	1.3
D1	2,47553	-0.4	2,43482	-1.5	2,51400	-0.9	2,58800	-1.4
C3	2,44534	-0.6	2,51496	0.1	2,57600	0.1	2,95400	1.6
B2	240,04080	1681.4	2,53289	0.4	2,58800	0.2	2,83000	0.6
F4	2,38042	-1.1	2,59645	1.6	2,63600	1.0	2,61400	-1.2
D3	2,88459	2.5	2,60822	1.8	2,90200	5.1	2,70400	-0.5
G1	2,54756	0.1	2,40315	-2.1	2,44200	-2.0	2,65800	-0.9
E1	2,53270	0.0	2,52197	0.2	2,56000	-0.2	2,67000	-0.8
E5	2,55310	0.2	2,53879	0.5	2,57400	0.0	2,86800	0.9
B3	2,55414	0.2	2,49687	-0.3	2,62600	0.9	2,84200	0.7
A5	2,68807	1.1	2,48334	-0.5	2,87000	4.6	2,86800	0.9
A4	2,61720	0.6	2,48334	-0.5	2,87000	4.6	2,86800	0.9
H2	2,47584	-0.4	2,50541	-0.1	2,54800	-0.4	2,79200	0.3
B4	2,04004	-3.5	2,41327	-1.9	2,46600	-1.6	2,65400	-0.9
F1	1,90169	-4.4	2,44107	-1.4	2,55600	-0.2	2,67000	-0.8
G3	2,68485	1.1	2,44665	-1.2	2,53000	-0.7	2,91200	1.3
D5	2,34660	-1.3	2,49794	-0.3	2,61600	0.7	2,55200	-1.7
F2	2,39174	-1.0	2,51831	0.1	2,51200	-0.9	2,66800	-0.8
C1	2,44272	-0.6	2,48499	-0.5	2,51600	-0.9	2,87600	1.0
E2	2,66822	1.0	2,58412	1.4	2,59600	0.4	2,94400	1.5
A3	2,87510	2.5	2,51911	0.1	2,68800	1.8	2,58800	-1.4
F5	2,67340	1.0	2,51381	0.0	2,55400	-0.3	2,78800	0.2
F3	0,02394	-17.7	2,41367	-1.9	2,47600	-1.5	2,56000	-1.7
H3	2,24501	-2.0	2,53462	0.4	2,99200	6.5	2,32400	-3.6
G2	2,54578	0.1	2,54851	0.7	2,57400	0.0	2,70800	-0.4
D4	2,52004	-0.1	2,52095	0.2	2,55000	-0.3	3,01800	2.1
G4	2,56360	0.2	2,58220	1.4	2,67400	1.6	2,95200	1.6
C2	2,58510	0.4	2,54635	0.7	2,61400	0.6	2,76600	0.0
C4	2,24255	-2.0	2,44570	-1.3	2,70800	2.1	2,51400	-2.1
H1	2,44364	-0.6	2,55388	0.8	2,65000	1.2	2,84800	0.7
A2	2,48176	-0.3	2,45674	-1.1	2,51600	-0.9	2,73400	-0.2
E4	2,58942	0.4	2,58216	1.3	3,15800	9.1	2,70200	-0.5
D2	2,92860	2.8	2,76233	4.8	2,84600	4.2	2,83000	0.6
B5*	0,55600	-14.0	2,80903	5.7	3,12600	8.6	2,77200	0.1

2.7.2 Tube C

Table 106.

Tube C				
	Is₁/I_{TSP}			
	ILC1	ILC2	ILC3	ILC4
Total number of data sets	39	39	39	39
Outliers	11	8	6	2
N. of data sets consid. for statistics	28	31	33	37
Degrees of freedom	27	30	32	36
Average	0.03918	0.03984	0.03808	0.04402
Interlaboratory standard deviation	0.00249	0.00162	0.00118	0.00194
CV%	6.4	4.1	3.1	4.4
Minimum	0.03398	0.03604	0.03530	0.04022
Maximum	0.04332	0.04373	0.04100	0.04854
Range	0.00934	0.00770	0.00570	0.00832
Median	0.03896	0.03957	0.03804	0.04430
Repeatability variance	0.0000023260	0.0000015088	0.0000043964	0.0000058334
Interlaboratory variance	0.0000057415	0.0000023340	0.0000005246	0.0000026108
Reproducibility variance	0.0000080675	0.0000038428	0.0000049210	0.0000084442
Confidence interval	0.00184	0.00120	0.00131	0.00162
Minimum confidence limit	0.03826	0.03924	0.03743	0.04320
Maximum confidence limit	0.04010	0.04044	0.03874	0.04483
Reproducibility limit	0.00823	0.00565	0.00638	0.00833

Table 107.

Tube		C						
Integral ratio			Is/ItSP					
Lab Code	ILC1 Average	ILC1 Z-score	ILC2 Average	ILC2 Z-score	ILC3 Average	ILC3 Z-score	ILC4 Average	ILC4 Z-score
C5	0,03582	-1.3	0,03857	-0.8	0,03814	0.0	0,04328	-0.4
E3	3,60146	1429.9	0,04044	0.4	0,03802	-0.1	0,04654	1.3
A1	0,03272	-2.6	0,04000	0.1	0,03414	-3.3	0,04562	0.8
H4	0,04284	1.5	0,03996	0.1	0,03828	0.2	0,04430	0.1
G5	0,03824	-0.4	0,03997	0.1	0,03912	0.9	0,04096	-1.6
B1	0,04001	0.3	0,03933	-0.3	0,03714	-0.8	0,04022	-2.0
D1	0,03680	-1.0	0,03911	-0.5	0,03656	-1.3	0,04428	0.1
C3	0,03559	-1.4	0,03604	-2.3	0,03378	-3.6	0,04186	-1.1
B2	3,89741	1548.7	0,03892	-0.6	0,03760	-0.4	0,04462	0.3
F4	0,03874	-0.2	0,03925	-0.4	0,03892	0.7	0,04574	0.9
D3	0,03898	-0.1	0,03773	-1.3	0,04078	2.3	0,04384	-0.1
G1	0,04272	1.4	0,04512	3.3	0,04100	2.5	0,04854	2.3
E1	0,04100	0.7	0,04150	1.0	0,03878	0.6	0,04348	-0.3
E5	0,03866	-0.2	0,03996	0.1	0,03796	-0.1	0,04536	0.7
B3	0,06828	11.7	0,04373	2.4	0,03924	1.0	0,04534	0.7
A5	0,03398	-2.1	0,03904	-0.5	0,03724	-0.7	0,04166	-1.2
A4	0,03490	-1.7	0,03904	-0.5	0,03724	-0.7	0,04166	-1.2
H2	0,04066	0.6	0,04126	0.9	0,03858	0.4	0,04470	0.4
B4	0,04121	0.8	0,03929	-0.3	0,03762	-0.4	0,04280	-0.6
F1	0,03878	-0.2	0,03952	-0.2	0,03846	0.3	0,04254	-0.8
G3	0,03732	-0.7	0,04231	1.5	0,03804	-0.0	0,04464	0.3
D5	0,04060	0.6	0,03845	-0.9	0,03768	-0.3	0,04440	0.2
F2	0,03894	-0.1	0,03873	-0.7	0,03832	0.2	0,04278	-0.6
C1	0,03958	0.2	0,03853	-0.8	0,03662	-1.2	0,04480	0.4
E2	0,03902	-0.1	0,04021	0.2	0,03934	1.1	0,04206	-1.0
A3	0,03482	-1.8	0,03896	-0.5	0,03672	-1.2	0,04206	-1.0
F5	0,03882	-0.1	0,03959	-0.2	0,03754	-0.5	0,04476	0.4
F3	2,36900	935.2	0,04118	0.8	0,03748	-0.5	0,04362	-0.2
H3	0,05056	4.6	0,03769	-1.3	0,03920	0.9	0,04656	1.3
G2	0,03776	-0.6	0,03957	-0.2	0,03836	0.2	0,04266	-0.7
D4	0,04126	0.8	0,04246	1.6	0,03912	0.9	0,04022	-2.0
G4	0,04164	1.0	0,04214	1.4	0,03932	1.0	0,04544	0.7
C2	0,03692	-0.9	0,04125	0.9	0,03752	-0.5	0,04772	1.9
C4	0,04294	1.5	0,03316	-4.1	0,03740	-0.6	0,04424	0.1
H1	0,04332	1.7	0,04073	0.5	0,03530	-2.3	0,04620	1.1
A2	0,04536	2.5	0,03728	-1.6	0,03428	-3.2	0,04480	0.4
E4	0,06902	12.0	0,03377	-3.7	0,03642	-1.4	0,04440	0.2
D2	0,03900	-0.1	0,03908	-0.5	0,03830	0.2	0,04410	0.0
B5*	0,08800	19.6	0,03150	-5.1	0,03134	-5.7	0,03328	-5.5

Table 108.

Tube C				
	Is2/ITS_P			
	ILC1	ILC2	ILC3	ILC4
Total number of data sets	39	39	39	39
Outliers	11	4	5	5
N. of data sets consid. for statistics	28	35	34	34
Degrees of freedom	27	34	33	33
Average	0.05362	0.06044	0.05483	0.10074
Interlaboratory standard deviation	0.006392	0.00297	0.00290	0.00515
CV%	11.9	4.9	5.3	5.1
Minimum	0.04167	0.05413	0.04792	0.09056
Maximum	0.06200	0.06816	0.05944	0.11520
Range	0.02033	0.01403	0.01152	0.02464
Median	0.05620	0.06009	0.05517	0.10175
Repeatability variance	0.0000033140	0.0000040109	0.0000032989	0.0000464716
Interlaboratory variance	0.0000401823	0.0000079907	0.0000077335	0.0000172225
Reproducibility variance	0.0000434963	0.0000120016	0.0000110324	0.0000636941
Confidence interval	0.00426	0.00199	0.00194	0.00465
Minimum confidence limit	0.05149	0.05944	0.05386	0.09841
Maximum confidence limit	0.05575	0.06143	0.05580	0.10306
Reproducibility limit	0.01911	0.00994	0.00955	0.02294

Table 109.

Tubo		C						
Integral ratio			Isz/ITSP					
Lab Code	ILC1 Average	ILC1 Z-score	ILC2 Average	ILC2 Z-score	ILC3 Average	ILC3 Z-score	ILC4 Average	ILC4 Z-score
C5	0,05652	0.5	0,05856	-0.6	0,05210	-0.9	0,10198	0.2
E3	4,08168	630.3	0,06022	-0.1	0,05522	0.1	0,10276	0.4
A1	0,05611	0.4	0,06290	0.8	0,04792	-2.4	0,10280	0.4
H4	0,04478	-1.4	0,06485	1.5	0,05582	0.3	0,10338	0.5
G5	0,05588	0.4	0,05825	-0.7	0,05662	0.6	0,10000	-0.1
B1	0,04957	-0.6	0,05671	-1.3	0,05404	-0.3	0,09750	-0.6
D1	0,05780	0.7	0,05929	-0.4	0,05578	0.3	0,10190	0.2
C3	0,04546	-1.3	0,06011	-0.1	0,05346	-0.5	0,09630	-0.9
B2	4,75480	735.6	0,05802	-0.8	0,05464	-0.1	0,10164	0.2
F4	0,04643	-1.1	0,05974	-0.2	0,06016	1.8	0,09208	-1.7
D3	0,05779	0.7	0,05413	-2.1	0,05436	-0.2	0,09970	-0.2
G1	0,06888	2.4	0,06816	2.6	0,06036	1.9	0,10780	1.4
E1	0,06032	1.0	0,06036	-0.0	0,05650	0.6	0,08720	-2.6
E5	0,05840	0.7	0,05935	-0.4	0,05874	1.3	0,10560	0.9
B3	0,08244	4.5	0,06290	0.8	0,05780	1.0	0,09502	-1.1
A5	0,05996	1.0	0,06242	0.7	0,04896	-2.0	0,09478	-1.2
A4	0,05971	0.9	0,06242	0.7	0,04896	-2.0	0,09478	-1.2
H2	0,05980	1.0	0,06061	0.1	0,05722	0.8	0,10600	1.0
B4	0,04280	-1.7	0,05738	-1.0	0,05486	0.0	0,10362	0.6
F1	0,04167	-1.9	0,05925	-0.4	0,05694	0.7	0,10260	0.4
G3	0,06200	1.3	0,06312	0.9	0,05636	0.5	0,11520	2.8
D5	0,04520	-1.3	0,05748	-1.0	0,05252	-0.8	0,09990	-0.2
F2	0,04586	-1.2	0,05689	-1.2	0,05512	0.1	0,09478	-1.2
C1	0,05709	0.5	0,05713	-1.1	0,05384	-0.3	0,10562	0.9
E2	0,05690	0.5	0,06044	0.0	0,05862	1.3	0,09820	-0.5
A3	0,04662	-1.1	0,05899	-0.5	0,05396	-0.3	0,09664	-0.8
F5	0,05406	0.1	0,05976	-0.2	0,05568	0.3	0,10638	1.1
F3	0,38260	51.5	0,06009	-0.1	0,05402	-0.3	0,09056	-2.0
H3	0,04950	-0.6	0,04702	-4.5	0,03467	-7.0	0,06348	-7.2
G2	0,05662	0.5	0,05820	-0.8	0,05704	0.8	0,10226	0.3
D4	0,06044	1.1	0,06162	0.4	0,05834	1.2	0,10720	1.3
G4	0,06176	1.3	0,06306	0.9	0,05944	1.6	0,12120	4.0
C2	0,05528	0.3	0,06538	1.7	0,05798	1.1	0,09574	-1.0
C4	0,04378	-1.5	0,05473	-1.9	0,04938	-1.9	0,09718	-0.7
H1	0,04650	-1.1	0,06238	0.7	0,05262	-0.8	0,10176	0.2
A2	0,06387	1.6	0,05973	-0.2	0,05210	-0.9	0,10304	0.4
E4	0,07700	3.7	0,05899	-0.5	0,05038	-1.5	0,09436	-1.2
D2	0,05220	-0.2	0,06613	1.9	0,05626	0.5	0,10174	0.2
B5*	0,08000	4.1	0,05423	-2.1	0,04932	-1.9	0,08208	-3.6

Table 110.

Tube C				
	Is₃/I_{TSP}			
	ILC1	ILC2	ILC3	ILC4
Total number of data sets	39	39	39	39
Outliers	6	9	4	1
N. of data sets consid. for statistics	33	30	35	38
Degrees of freedom	32	29	34	37
Average	0.54392	0.57051	0.59228	0.51484
Interlaboratory standard deviation	0.06772	0.02950	0.04084	0.06870
CV%	12.5	5.2	6.9	13.3
Minimum	0.42015	0.50670	0.50800	0.39660
Maximum	0.67400	0.63512	0.68040	0.66280
Range	0.25385	0.12841	0.17240	0.26620
Median	0.56252	0.57048	0.58540	0.51510
Repeatability variance	0.0004506384	0.0003057306	0.0007091543	0.0018970658
Interlaboratory variance	0.0044962241	0.0008093880	0.0015260496	0.0043407991
Reproducibility variance	0.0049468625	0.0011151186	0.0022352039	0.0062378649
Confidence interval	0.04163	0.02073	0.02717	0.04343
Minimum confidence limit	0.52310	0.56014	0.57869	0.49306
Maximum confidence limit	0.56473	0.58087	0.60587	0.53649
Reproducibility limit	0.20237	0.09644	0.13573	0.22610

Table 111.

Tube	C							
Integral ratio	Is3/ItSP							
Lab Code	ILC1 Average	ILC1 Z-score	ILC2 Average	ILC2 Z-score	ILC3 Average	ILC3 Z-score	ILC4 Average	ILC4 Z-score
C5	0,58456	0.6	0,57650	0.2	0,58540	-0.2	0,46100	-0.8
E3	48,08980	702.1	0,60962	1.3	0,58360	-0.2	0,49940	-0.2
A1	0,63119	1.3	0,66484	3.2	0,59540	0.1	0,55380	0.6
H4	0,56818	0.4	0,59110	0.7	0,60620	0.3	0,51380	-0.0
G5	0,54272	0.0	0,54946	-0.7	0,56160	-0.8	0,54140	0.4
B1	0,48263	-0.9	0,50670	-2.2	0,50800	-2.1	0,50800	-0.1
D1	0,55433	0.2	0,55775	-0.4	0,57720	-0.4	0,42120	-1.4
C3	0,55110	0.1	0,61636	1.6	0,60420	0.3	0,61220	1.4
B2	48,25224	704.5	0,55489	-0.5	0,56240	-0.7	0,60400	1.3
F4	0,48042	-0.9	0,59134	0.7	0,62600	0.8	0,45580	-0.9
D3	0,70555	2.4	0,48294	-3.0	0,63920	1.1	0,54740	0.5
G1	0,66460	1.8	0,63274	2.1	0,63420	1.0	0,52000	0.1
E1	0,56948	0.4	0,56502	-0.2	0,56200	-0.7	0,56520	0.7
E5	0,56776	0.4	0,56068	-0.3	0,61840	0.6	0,59880	1.2
B3	0,62260	1.2	0,58222	0.4	0,61000	0.4	0,48100	-0.5
A5	0,60923	1.0	0,58791	0.6	0,63000	0.9	0,42700	-1.3
A4	0,59194	0.7	0,58791	0.6	0,63000	0.9	0,42700	-1.3
H2	0,56252	0.3	0,56933	-0.0	0,57760	-0.4	0,58680	1.0
B4	0,42148	-1.8	0,51695	-1.8	0,52580	-1.6	0,42960	-1.2
F1	0,42015	-1.8	0,53751	-1.1	0,54640	-1.1	0,46260	-0.8
G3	0,65131	1.6	0,57095	0.0	0,58180	-0.3	0,48840	-0.4
D5	0,42940	-1.7	0,50862	-2.1	0,55500	-0.9	0,39660	-1.7
F2	0,45494	-1.3	0,51293	-2.0	0,51980	-1.8	0,51640	0.0
C1	0,54406	0.0	0,55858	-0.4	0,57780	-0.4	0,60420	1.3
E2	0,58780	0.6	0,57821	0.3	0,58960	-0.1	0,57980	0.9
A3	0,61604	1.1	0,57268	0.1	0,67940	2.1	0,45520	-0.9
F5	0,58022	0.5	0,57007	-0.0	0,58560	-0.2	0,58060	1.0
F3	0,50578	-0.6	0,56458	-0.2	0,56360	-0.7	0,40880	-1.5
H3	0,44655	-1.4	0,65221	2.8	0,68040	2.2	0,47600	-0.6
G2	0,55042	0.1	0,55430	-0.5	0,57420	-0.4	0,57180	0.8
D4	0,57014	0.4	0,57088	0.0	0,59060	-0.0	0,56860	0.8
G4	0,59438	0.7	0,60884	1.3	0,62840	0.9	0,66280	2.2
C2	0,58342	0.6	0,61309	1.4	0,63220	1.0	0,48740	-0.4
C4	0,44139	-1.5	0,57846	0.3	0,69740	2.6	0,58000	0.9
H1	0,47414	-1.0	0,57493	0.1	0,57500	-0.4	0,44360	-1.0
A2	0,56370	0.3	0,56013	-0.4	0,57800	-0.3	0,42980	-1.2
E4	0,53734	-0.1	0,65220	2.8	0,69480	2.5	0,58020	1.0
D2	0,67400	1.9	0,63512	2.2	0,66080	1.7	0,51780	0.0
B5*	0,23000	-4.6	0,56615	-0.1	0,60140	0.2	0,36960	-2.1

Table 112.

Tube C				
	Is4/ITS_P			
	ILC1	ILC2	ILC3	ILC4
Total number of data sets	39	39	39	39
Outliers	9	15	6	11
N. of data sets consid. for statistics	30	24	33	28
Degrees of freedom	29	23	32	27
Average	0.53821	0.55106	0.57462	0.51270
Interlaboratory standard deviation	0.05475	0.02521	0.04210	0.02580
CV%	10.2	4.6	7.3	5.0
Minimum	0.43900	0.48487	0.47620	0.44940
Maximum	0.66260	0.60957	0.66860	0.56660
Range	0.22360	0.12470	0.19240	0.11720
Median	0.54709	0.55016	0.56960	0.51370
Repeatability variance	0.0003869745	0.0003078096	0.0007519333	0.0003751393
Interlaboratory variance	0.0029196806	0.0005741922	0.0016223352	0.0005904225
Reproducibility variance	0.0033066551	0.0008820018	0.0023742685	0.0009655618
Confidence interval	0.03570	0.02073	0.02884	0.02008
Minimum confidence limit	0.52037	0.54069	0.56020	0.50266
Maximum confidence limit	0.55606	0.56142	0.58904	0.52274
Reproducibility limit	0.16608	0.08668	0.14020	0.09002

Table 113.

Tube		C						
Integral ratio			Is4/ItSP					
Lab Code	ILC1 Average	ILC1 Z-score	ILC2 Average	ILC2 Z-score	ILC3 Average	ILC3 Z-score	ILC4 Average	ILC4 Z-score
C5	0,58152	0.8	0,57046	0.8	0,58140	0.2	0,51400	0.1
E3	48,98568	885.0	0,58666	1.4	0,56340	-0.3	0,53380	0.8
A1	0,64046	1.9	0,67265	4.8	0,60680	0.8	0,67780	6.4
H4	0,57166	0.6	0,58154	1.2	0,60160	0.6	0,55300	1.6
G5	0,54140	0.1	0,53641	-0.6	0,54660	-0.7	0,49300	-0.8
B1	0,45739	-1.5	0,47428	-3.0	0,47620	-2.3	0,43620	-3.0
D1	0,53475	-0.1	0,53599	-0.6	0,55240	-0.5	0,48700	-1.0
C3	0,51894	-0.4	0,62283	2.8	0,61660	1.0	0,51740	0.2
B2	50,17008	906.6	0,54665	-0.2	0,55180	-0.5	0,53960	1.0
F4	0,50539	-0.6	0,60341	2.1	0,60540	0.7	0,50340	-0.4
D3	0,69684	2.9	0,45639	-3.8	0,62720	1.2	0,55960	1.8
G1	0,67710	2.5	0,64545	3.7	0,65200	1.8	0,56660	2.1
E1	0,55626	0.3	0,55179	0.0	0,55160	-0.5	0,51080	-0.1
E5	0,56642	0.5	0,55959	0.3	0,61140	0.9	0,56200	1.9
B3	0,58584	0.9	0,53234	-0.7	0,58060	0.1	0,51480	0.1
A5	0,57696	0.7	0,55982	0.3	0,60660	0.8	0,47260	-1.6
A4	0,56072	0.4	0,55982	0.3	0,60660	0.8	0,47260	-1.6
H2	0,55252	0.3	0,55864	0.3	0,56680	-0.2	0,51720	0.2
B4	0,46926	-1.3	0,52116	-1.2	0,53060	-1.0	0,52980	0.7
F1	0,46058	-1.4	0,52463	-1.0	0,53620	-0.9	0,50020	-0.5
G3	0,61266	1.4	0,53831	-0.5	0,54880	-0.6	0,52740	0.6
D5	0,43900	-1.8	0,48487	-2.6	0,52580	-1.2	0,44940	-2.5
F2	0,45268	-1.6	0,48419	-2.7	0,48880	-2.0	0,43380	-3.1
C1	0,53460	-0.1	0,55016	-0.0	0,57280	-0.0	0,56300	1.9
E2	0,58608	0.9	0,57564	1.0	0,58680	0.3	0,51900	0.2
A3	0,60460	1.2	0,55555	0.2	0,66860	2.2	0,51340	0.0
F5	0,58248	0.8	0,56856	0.7	0,58640	0.3	0,55960	1.8
F3	0,56942	0.6	0,54249	-0.3	0,54440	-0.7	0,47500	-1.5
H3	0,46280	-1.4	0,68142	5.2	0,71240	3.3	0,51060	-0.1
G2	0,53532	-0.1	0,53882	-0.5	0,55540	-0.5	0,51220	-0.0
D4	0,54954	0.2	0,55016	-0.0	0,56960	-0.1	0,52960	0.7
G4	0,59394	1.0	0,60957	2.3	0,63140	1.3	0,59220	3.1
C2	0,56608	0.5	0,58945	1.5	0,60940	0.8	0,53560	0.9
C4	0,46574	-1.3	0,55485	0.2	0,68860	2.7	0,51020	-0.1
H1	0,50176	-0.7	0,54996	-0.0	0,55300	-0.5	0,51240	-0.0
A2	0,54464	0.1	0,54161	-0.4	0,55920	-0.4	0,50360	-0.4
E4	0,53986	0.0	0,69106	5.6	0,74480	4.0	0,67040	6.1
D2	0,66260	2.3	0,62208	2.8	0,64780	1.7	0,54160	1.1
B5*	0,21400	-5.9	0,58079	1.2	0,62040	1.1	0,45840	-2.1

Table 114.

Tube C				
	Iss/I _{TSP}			
	ILC1	ILC2	ILC3	ILC4
Total number of data sets	39	39	39	39
Outliers	15	12	8	5
N. of data sets consid. for statistics	24	27	31	34
Degrees of freedom	23	26	30	33
Average	0.62481	0.63740	0.65479	0.66038
Interlaboratory standard deviation	0.16279	0.14807	0.14994	0.11461
CV%	26.1	23.2	22.9	17.4
Minimum	0.22800	0.33345	0.34720	0.42800
Maximum	0.93900	0.86998	0.96100	0.90940
Range	0.71100	0.53652	0.61380	0.48140
Median	0.64455	0.65251	0.65480	0.70700
Repeatability variance	0.0005102349	0.0024441481	0.0044051484	0.0036052324
Interlaboratory variance	0.0263994233	0.0214351288	0.0216012303	0.0124133932
Reproducibility variance	0.0269096582	0.0238792769	0.0260063787	0.0160186256
Confidence interval	0.11452	0.10171	0.09848	0.07380
Minimum confidence limit	0.56755	0.58653	0.60555	0.62348
Maximum confidence limit	0.68207	0.68824	0.70403	0.69728
Reproducibility limit	0.47878	0.44839	0.46513	0.36374

Table 115.

Tube		C						
Integral ratio			Iss/I _{TSP}					
Lab Code	ILC1 Average	ILC1 Z-score	ILC2 Average	ILC2 Z-score	ILC3 Average	ILC3 Z-score	ILC4 Average	ILC4 Z-score
C5	0,54552	-0.5	0,52570	-0.8	0,53860	-0.8	0,55760	-0.9
E3	63,59426	386.8	0,70940	0.5	0,73020	0.5	0,75740	0.8
A1	0,61118	-0.1	0,55361	-0.6	0,65480	0.0	0,91620	2.2
H4	0,79184	1.0	0,79679	1.1	0,82960	1.2	0,90940	2.2
G5	0,73398	0.7	0,72359	0.6	0,73380	0.5	0,71760	0.5
B1	0,55443	-0.4	0,54656	-0.6	0,55040	-0.7	0,53840	-1.1
D1	0,51072	-0.7	0,50793	-0.9	0,51780	-0.9	0,56980	-0.8
C3	0,69532	0.4	0,53833	-0.7	0,54900	-0.7	0,72120	0.5
B2	62,40426	379.5	0,84808	1.4	0,85900	1.4	0,71480	0.5
F4	0,65279	0.2	0,60734	-0.2	0,91020	1.7	0,71540	0.5
D3	0,81690	1.2	1,08512	3.0	0,96100	2.0	0,70460	0.4
G1	0,43572	-1.2	0,42400	-1.4	0,42700	-1.5	0,76280	0.9
E1	0,74960	0.8	0,74282	0.7	0,74860	0.6	0,70940	0.4
E5	0,76080	0.8	0,75541	0.8	0,77040	0.8	0,79460	1.2
B3	0,71612	0.6	0,82417	1.3	0,71140	0.4	0,80500	1.3
A5	0,56097	-0.4	0,51186	-0.8	0,52160	-0.9	0,58100	-0.7
A4	0,55223	-0.4	0,51186	-0.8	0,52160	-0.9	0,58100	-0.7
H2	0,69910	0.5	0,70181	0.4	0,71280	0.4	0,72500	0.6
B4	0,35407	-1.7	0,50286	-0.9	0,51520	-0.9	0,45760	-1.8
F1	0,41578	-1.3	0,67251	0.2	0,67100	0.1	0,68260	0.2
G3	0,51006	-0.7	0,46008	-1.2	0,46660	-1.3	0,54620	-1.0
D5	0,29720	-2.0	0,33345	-2.1	0,34720	-2.1	0,31760	-3.0
F2	0,41756	-1.3	0,44124	-1.3	0,44840	-1.4	0,42800	-2.0
C1	0,63631	0.1	0,65715	0.1	0,63260	-0.1	0,74560	0.7
E2	0,78318	1.0	0,77162	0.9	0,77180	0.8	0,75820	0.9
A3	0,65994	0.2	0,63704	-0.0	0,57880	-0.5	0,60440	-0.5
F5	0,96296	2.1	0,89200	1.7	0,91360	1.7	0,61480	-0.4
F3	0,59208	-0.2	0,48582	-1.0	0,49320	-1.1	0,53060	-1.1
H3	0,46457	-1.0	0,64343	0.0	0,86840	1.4	0,53560	-1.1
G2	0,74184	0.7	0,74615	0.7	0,75980	0.7	0,75960	0.9
D4	0,78540	1.0	0,78879	1.0	0,78840	0.9	0,73880	0.7
G4	0,71708	0.6	0,65251	0.1	0,64500	-0.1	0,72300	0.5
C2	0,60052	-0.1	0,54946	-0.6	0,56120	-0.6	0,63720	-0.2
C4	0,51694	-0.7	1,62849	6.7	1,71020	7.0	0,58260	-0.7
H1	0,40434	-1.3	0,81708	1.2	0,84980	1.3	0,44720	-1.9
A2	0,52523	-0.6	0,52894	-0.7	0,51680	-0.9	0,56480	-0.8
E4	0,60116	-0.1	0,28333	-2.4	0,28364	-2.5	1,13360	4.1
D2	0,93900	1.9	0,86998	1.6	0,89120	1.6	0,77740	1.0
B5*	0,22800	-2.4	0,66536	0.2	0,72720	0.5	0,59300	-0.6

Table 116.

Tube C				
	Is₆/I_{TSP}			
	ILC1	ILC2	ILC3	ILC4
Total number of data sets	39	39	39	39
Outliers	9	11	9	4
N. of data sets consid. for statistics	30	28	30	35
Degrees of freedom	29	27	29	34
Average	0.33682	0.36363	0.37747	0.32478
Interlaboratory standard deviation	0.06419	0.01799	0.01571	0.02859
CV%	19.1	4.9	4.2	8.8
Minimum	0.21598	0.33044	0.34240	0.28180
Maximum	0.46060	0.41837	0.40960	0.38960
Range	0.24462	0.08793	0.06720	0.10780
Median	0.35581	0.36230	0.37800	0.32700
Repeatability variance	0.0001705228	0.0001355099	0.0002862200	0.0002835086
Interlaboratory variance	0.0040866252	0.0002966777	0.0001895762	0.0007608224
Reproducibility variance	0.0042571480	0.0004321876	0.0004757962	0.0010443310
Confidence interval	0.04050	0.01344	0.01354	0.01857
Minimum confidence limit	0.31657	0.35692	0.37070	0.31549
Maximum confidence limit	0.35707	0.37035	0.38424	0.33406
Reproducibility limit	0.18844	0.06022	0.06300	0.09278

Table 117.

Tube		C						
Integral ratio			Is ₆ /I _{TSP}					
Lab Code	ILC1 Average	ILC1 Z-score	ILC2 Average	ILC2 Z-score	ILC3 Average	ILC3 Z-score	ILC4 Average	ILC4 Z-score
C5	0,36950	0.5	0,36101	-0.1	0,37440	-0.2	0,32100	-0.1
E3	34,03500	525.0	0,41028	2.6	0,40340	1.7	0,34000	0.5
A1	0,37328	0.6	0,37414	0.6	0,37100	-0.4	0,33740	0.4
H4	0,30792	-0.4	0,37091	0.4	0,38620	0.6	0,31360	-0.4
G5	0,37554	0.6	0,37075	0.4	0,38260	0.3	0,33660	0.4
B1	0,29258	-0.7	0,36145	-0.1	0,36420	-0.8	0,33540	0.4
D1	0,35674	0.3	0,35904	-0.3	0,37740	-0.0	0,30060	-0.8
C3	0,34778	0.2	0,30542	-3.2	0,30160	-4.8	0,32640	0.1
B2	24,50664	376.5	0,35961	-0.2	0,37100	-0.4	0,36700	1.5
F4	0,25520	-1.3	0,33558	-1.6	0,41120	2.1	0,31400	-0.4
D3	0,40510	1.1	0,37491	0.6	0,40880	2.0	0,36100	1.3
G1	0,37318	0.6	0,35557	-0.4	0,35740	-1.3	0,35600	1.1
E1	0,37960	0.7	0,37562	0.7	0,37580	-0.1	0,32980	0.2
E5	0,35572	0.3	0,35078	-0.7	0,38340	0.4	0,37060	1.6
B3	0,40384	1.0	0,43583	4.0	0,40960	2.0	0,28760	-1.3
A5	0,37290	0.6	0,34383	-1.1	0,37180	-0.4	0,29460	-1.1
A4	0,36118	0.4	0,34383	-1.1	0,37180	-0.4	0,29460	-1.1
H2	0,35062	0.2	0,36638	0.2	0,37540	-0.1	0,35680	1.1
B4	0,27913	-0.9	0,36826	0.3	0,37860	0.1	0,33040	0.2
F1	0,23521	-1.6	0,36316	-0.0	0,36700	-0.7	0,31240	-0.4
G3	0,43346	1.5	0,37129	0.4	0,38440	0.4	0,35840	1.2
D5	0,23460	-1.6	0,33712	-1.5	0,37940	0.1	0,28500	-1.4
F2	0,24934	-1.4	0,34908	-0.8	0,35960	-1.1	0,29940	-0.9
C1	0,33331	-0.1	0,34220	-1.2	0,34380	-2.1	0,32700	0.1
E2	0,38270	0.7	0,37335	0.5	0,38080	0.2	0,30900	-0.6
A3	0,37624	0.6	0,34593	-1.0	0,38360	0.4	0,28180	-1.5
F5	0,34804	0.2	0,33044	-1.8	0,34240	-2.2	0,33860	0.5
F3	0,05264	-4.4	0,35594	-0.4	0,36020	-1.1	0,29180	-1.2
H3	0,21598	-1.9	0,30057	-3.5	0,36300	-0.9	0,28560	-1.4
G2	0,37166	0.5	0,37348	0.5	0,38920	0.7	0,33000	0.2
D4	0,38222	0.7	0,38153	1.0	0,39360	1.0	0,38360	2.1
G4	0,37252	0.6	0,37790	0.8	0,38660	0.6	0,38960	2.3
C2	0,37564	0.6	0,38509	1.2	0,40240	1.6	0,32880	0.1
C4	0,22322	-1.8	0,33143	-1.8	0,35660	-1.3	0,28240	-1.5
H1	0,26870	-1.1	0,37896	0.9	0,38920	0.7	0,31720	-0.3
A2	0,35591	0.3	0,35791	-0.3	0,37220	-0.3	0,29200	-1.1
E4	0,30300	-0.5	0,26491	-5.5	0,28520	-5.9	0,33040	0.2
D2	0,46060	1.9	0,41837	3.0	0,44340	4.2	0,33280	0.3
B5*	0,11600	-3.4	0,33573	-1.6	0,36460	-0.8	0,24180	-2.9

Table 118.

Tube C				
	Is7/ITS_P			
	ILC1	ILC2	ILC3	ILC4
Total number of data sets	39	39	39	39
Outliers	9	8	9	4
N. of data sets consid. for statistics	30	31	30	35
Degrees of freedom	29	30	29	34
Average	2.33688	2.33037	2.39980	2.51840
Interlaboratory standard deviation	0.17810	0.07366	0.08390	0.13358
CV%	7.6	3.2	3.5	5.3
Minimum	1.98634	2.23658	2.29000	2.22600
Maximum	2.77700	2.53305	2.57000	2.84600
Range	0.79066	0.29647	0.28000	0.62000
Median	2.34982	2.32749	2.37600	2.50800
Repeatability variance	0.0017573614	0.0008390800	0.0018663333	0.0126440000
Interlaboratory variance	0.0313674854	0.0052574064	0.0066662782	0.0153158588
Reproducibility variance	0.0331248468	0.0060964864	0.0085326115	0.0279598588
Confidence interval	0.11298	0.04768	0.05734	0.09610
Minimum confidence limit	2.28039	2.30653	2.37113	2.47035
Maximum confidence limit	2.39336	2.35421	2.42847	2.56645
Reproducibility limit	0.52564	0.22521	0.26678	0.48006

Table 119.

Tube	C							
Integral ratio	Is7/ITSP							
Lab Code	ILC1 Average	ILC1 Z-score	ILC2 Average	ILC2 Z-score	ILC3 Average	ILC3 Z-score	ILC4 Average	ILC4 Z-score
C5	2,46404	0.7	2,36058	0.4	2,45000	0.6	2,47800	-0.3
E3	218,30122	1212.6	2,29164	-0.5	2,32000	-1.0	2,56400	0.3
A1	2,43883	0.6	2,34412	0.2	2,47600	0.9	2,59000	0.5
H4	2,57652	1.3	2,40166	1.0	2,55200	1.8	2,62000	0.8
G5	2,37268	0.2	2,32380	-0.1	2,33800	-0.7	2,48400	-0.3
B1	2,31597	-0.1	2,26411	-0.9	2,29600	-1.2	2,50800	-0.1
D1	2,28384	-0.3	2,25500	-1.0	2,29800	-1.2	2,40000	-0.9
C3	2,22100	-0.7	2,40442	1.0	2,48000	1.0	2,55400	0.3
B2	214,07380	1188.9	2,32335	-0.1	2,34800	-0.6	2,58800	0.5
F4	2,15042	-1.0	2,40610	1.0	2,35600	-0.5	2,51800	-0.0
D3	2,62822	1.6	2,38454	0.7	2,64400	2.9	2,55600	0.3
G1	2,65308	1.8	2,55055	3.0	2,67600	3.3	2,83200	2.3
E1	2,35734	0.1	2,34159	0.2	2,38200	-0.2	2,44000	-0.6
E5	2,35658	0.1	2,33426	0.1	2,39400	-0.1	2,67800	1.2
B3	2,34306	0.0	2,34769	0.2	2,42600	0.3	2,51400	-0.0
A5	2,46022	0.7	2,26332	-0.9	2,53200	1.6	2,47800	-0.3
A4	2,37994	0.2	2,26332	-0.9	2,53200	1.6	2,47800	-0.3
H2	2,32896	0.0	2,32749	-0.0	2,37000	-0.4	2,57000	0.4
B4	1,87330	-2.6	2,24365	-1.2	2,29000	-1.3	2,48200	-0.3
F1	1,98634	-2.0	2,27209	-0.8	2,32400	-0.9	2,41400	-0.8
G3	2,64160	1.7	2,36600	0.5	2,43400	0.4	2,69200	1.3
D5	2,14220	-1.1	2,26555	-0.9	2,43200	0.4	2,41400	-0.8
F2	2,17128	-0.9	2,32810	-0.0	2,34200	-0.7	2,36600	-1.1
C1	2,24148	-0.5	2,29404	-0.5	2,33000	-0.8	2,66400	1.1
E2	2,43456	0.5	2,38660	0.8	2,40400	0.1	2,51600	-0.0
A3	2,56594	1.3	2,30860	-0.3	2,51800	1.4	2,38800	-1.0
F5	2,44752	0.6	2,28150	-0.7	2,36600	-0.4	2,62000	0.8
F3	0,03906	-12.9	2,23658	-1.3	2,29800	-1.2	2,31000	-1.6
H3	2,00433	-1.9	2,30770	-0.3	2,76200	4.3	2,22600	-2.2
G2	2,32672	-0.1	2,33808	0.1	2,36400	-0.4	2,47600	-0.3
D4	2,36880	0.2	2,36595	0.5	2,41800	0.2	2,84600	2.5
G4	2,48696	0.8	2,51559	2.5	2,57000	2.0	2,92400	3.0
C2	2,50942	1.0	2,45667	1.7	2,56800	2.0	2,64400	0.9
C4	2,02914	-1.7	2,31462	-0.2	2,62400	2.7	2,28800	-1.7
H1	2,22698	-0.6	2,26274	-0.9	2,36000	-0.5	2,58400	0.5
A2	2,29209	-0.3	2,28127	-0.7	2,33400	-0.8	2,50200	-0.1
E4	2,54698	1.2	2,56215	3.1	2,89400	5.9	2,47400	-0.3
D2	2,77700	2.5	2,53305	2.8	2,62800	2.7	2,56400	0.3
B5*	0,63200	-9.6	2,12352	-2.8	2,33000	-0.8	1,99800	-3.9

2.7.3 Tube D

Table 120.

Tube D				
	Is1/ItSP			
	ILC1	ILC2	ILC3	ILC4
Total number of data sets	39	39	39	39
Outliers	11	9	7	3
N. of data sets consid. for statistics	28	30	32	36
Degrees of freedom	27	29	31	35
Average	0.03409	0.03488	0.03279	0.03841
Interlaboratory standard deviation	0.00218	0.00147	0.00123	0.00141
CV%	6.4	4.2	3.8	3.7
Minimum	0.02761	0.03095	0.029320	0.03588
Maximum	0.03748	0.03713	0.034800	0.04118
Range	0.00987	0.00619	0.005480	0.00530
Median	0.03468	0.03487	0.033000	0.03840
Repeatability variance	0.0000024620	0.0000011876	0.0000035579	0.0000035249
Interlaboratory variance	0.0000042525	0.0000019256	0.0000008062	0.0000012953
Reproducibility variance	0.0000067145	0.0000031132	0.0000043641	0.0000048202
Confidence interval	0.00167	0.00110	0.00126	0.00124
Minimum confidence limit	0.03325	0.03433	0.03216	0.03779
Maximum confidence limit	0.03493	0.03543	0.03341	0.03903
Reproducibility limit	0.00751	0.00510	0.006018	0.00630

Table 121.

Tube		D						
Integral ratio		IsI/ItSP						
Lab Code	ILC1 Average	ILC1 Z-score	ILC2 Average	ILC2 Z-score	ILC3 Average	ILC3 Z-score	ILC4 Average	ILC4 Z-score
C5	0,03244	-0.8	0,03333	-1.1	0,03408	1.1	0,03956	0.8
E3	3,26212	1481.9	0,03431	-0.4	0,03192	-0.7	0,03884	0.3
A1	0,02761	-3.0	0,03615	0.9	0,02932	-2.8	0,03906	0.5
H4	0,03622	1.0	0,03870	2.6	0,03356	0.6	0,03894	0.4
G5	0,03334	-0.3	0,03460	-0.2	0,03360	0.7	0,03598	-1.7
B1	0,03477	0.3	0,03468	-0.1	0,03218	-0.5	0,03638	-1.4
D1	0,03187	-1.0	0,03384	-0.7	0,03224	-0.4	0,03888	0.3
C3	0,03106	-1.4	0,03021	-3.2	0,03198	-0.7	0,03886	0.3
B2	3,45056	1568.4	0,03335	-1.0	0,03432	1.2	0,03898	0.4
F4	0,03668	1.2	0,03375	-0.8	0,03370	0.7	0,03836	-0.0
D3	0,03497	0.4	0,03488	-0.0	0,03786	4.1	0,03620	-1.6
G1	0,03354	-0.3	0,03446	-0.3	0,03152	-1.0	0,03980	1.0
E1	0,03588	0.8	0,03623	0.9	0,03298	0.2	0,03812	-0.2
E5	0,03402	-0.0	0,03552	0.4	0,03326	0.4	0,03934	0.7
B3	0,06212	12.9	0,03559	0.5	0,03316	0.3	0,04070	1.6
A5	0,03210	-0.9	0,03711	1.5	0,03800	4.2	0,04030	1.3
A4	0,03270	-0.6	0,03711	1.5	0,03800	4.2	0,04030	1.3
H2	0,03554	0.7	0,03564	0.5	0,03352	0.6	0,03732	-0.8
B4	0,03298	-0.5	0,03538	0.3	0,03286	0.1	0,03736	-0.7
F1	0,03151	-1.2	0,03519	0.2	0,03228	-0.4	0,03814	-0.2
G3	0,03220	-0.9	0,03624	0.9	0,03212	-0.5	0,04004	1.2
D5	0,03460	0.2	0,03156	-2.3	0,03044	-1.9	0,03894	0.4
F2	0,03476	0.3	0,03389	-0.7	0,03430	1.2	0,03756	-0.6
C1	0,03664	1.2	0,03387	-0.7	0,03302	0.2	0,03812	-0.2
E2	0,03640	1.1	0,03487	-0.0	0,03472	1.6	0,03826	-0.1
A3	0,03864	2.1	0,03137	-2.4	0,03306	0.2	0,03700	-1.0
F5	0,03538	0.6	0,03473	-0.1	0,03306	0.2	0,03660	-1.3
F3	3,04098	1380.4	0,03503	0.1	0,03244	-0.3	0,03688	-1.1
H3	0,04385	4.5	0,02295	-8.1	0,02938	-2.8	0,03708	-0.9
G2	0,03310	-0.5	0,03447	-0.3	0,03326	0.4	0,03730	-0.8
D4	0,03526	0.5	0,03713	1.5	0,03398	1.0	0,03588	-1.8
G4	0,03476	0.3	0,03597	0.7	0,03480	1.6	0,03914	0.5
C2	0,03392	-0.1	0,03559	0.5	0,03274	-0.0	0,04118	2.0
C4	0,03632	1.0	0,03321	-1.1	0,03468	1.5	0,03754	-0.6
H1	0,03748	1.6	0,03660	1.2	0,03266	-0.1	0,04044	1.4
A2	0,03607	0.9	0,03511	0.2	0,03102	-1.4	0,03972	0.9
E4	0,06792	15.5	0,03453	-0.2	0,03108	-1.4	0,03794	-0.3
D2	0,03400	-0.0	0,03095	-2.7	0,03314	0.3	0,03844	0.0
B5*	0,09000	25.7	0,02552	-6.4	0,02640	-5.2	0,02876	-6.8

Table 122.

Tube D				
	Is2/ITS_P			
	ILC1	ILC2	ILC3	ILC4
Total number of data sets	39	39	39	39
Outliers	10	5	9	2
N. of data sets consid. for statistics	29	34	30	37
Degrees of freedom	28	33	29	36
Average	0.04410	0.04863	0.04370	0.03982
Interlaboratory standard deviation	0.00392	0.00284	0.00172	0.00145
CV%	8.9	5.8	3.9	3.6
Minimum	0.03493	0.04361	0.04046	0.03684
Maximum	0.04962	0.05528	0.04674	0.04282
Range	0.01469	0.01166	0.00628	0.00598
Median	0.04476	0.04813	0.04387	0.03982
Repeatability variance	0.0000042055	0.0000057409	0.0000035057	0.0000030377
Interlaboratory variance	0.0000145499	0.0000068948	0.0000022543	0.0000015047
Reproducibility variance	0.0000187554	0.0000126357	0.0000057600	0.0000045424
Confidence interval	0.00273	0.00207	0.00149	0.00119
Minimum confidence limit	0.04273	0.04759	0.04295	0.03923
Maximum confidence limit	0.04547	0.04966	0.04444	0.04042
Reproducibility limit	0.01253	0.01022	0.00693	0.00611

Table 123.

Tube		D						
Integral ratio			Isz/I _{TSP}					
Lab Code	ILC1 Average	ILC1 Z-score	ILC2 Average	ILC2 Z-score	ILC3 Average	ILC3 Z-score	ILC4 Average	ILC4 Z-score
C5	0,04466	0.1	0,04564	-1.1	0,04080	-1.7	0,04084	0.7
E3	3,34780	842.1	0,04797	-0.2	0,04186	-1.1	0,03956	-0.2
A1	0,04425	0.0	0,05158	1.0	0,03702	-3.9	0,03996	0.1
H4	0,04044	-0.9	0,05528	2.3	0,04288	-0.5	0,04250	1.8
G5	0,04476	0.2	0,04610	-0.9	0,04432	0.4	0,03814	-1.2
B1	0,03944	-1.2	0,04557	-1.1	0,04306	-0.4	0,03872	-0.8
D1	0,04553	0.4	0,04708	-0.5	0,04434	0.4	0,03926	-0.4
C3	0,03493	-2.3	0,03710	-4.1	0,04154	-1.3	0,03926	-0.4
B2	3,98950	1005.7	0,04631	-0.8	0,04308	-0.4	0,03968	-0.1
F4	0,03866	-1.4	0,04508	-1.3	0,04500	0.8	0,03684	-2.1
D3	0,04562	0.4	0,04361	-1.8	0,04184	-1.1	0,03806	-1.2
G1	0,05016	1.5	0,04813	-0.2	0,04200	-1.0	0,03998	0.1
E1	0,04914	1.3	0,04912	0.2	0,04478	0.6	0,04020	0.3
E5	0,04628	0.6	0,04833	-0.1	0,04648	1.6	0,04144	1.1
B3	0,07090	6.8	0,04992	0.5	0,04724	2.1	0,04010	0.2
A5	0,04961	1.4	0,05233	1.3	0,03716	-3.8	0,03932	-0.3
A4	0,04962	1.4	0,05233	1.3	0,03716	-3.8	0,03932	-0.3
H2	0,04778	0.9	0,04834	-0.1	0,04544	1.0	0,04120	0.9
B4	0,03209	-3.1	0,04737	-0.4	0,04380	0.1	0,03982	-0.0
F1	0,03187	-3.1	0,04950	0.3	0,04394	0.1	0,03912	-0.5
G3	0,04879	1.2	0,05160	1.0	0,04380	0.1	0,04224	1.7
D5	0,03720	-1.8	0,04583	-1.0	0,04108	-1.5	0,03994	0.1
F2	0,03852	-1.4	0,04575	-1.0	0,04502	0.8	0,03846	-0.9
C1	0,04705	0.8	0,04612	-0.9	0,04350	-0.1	0,03930	-0.4
E2	0,04662	0.6	0,04720	-0.5	0,04674	1.8	0,04032	0.3
A3	0,04416	0.0	0,04657	-0.7	0,04358	-0.1	0,03800	-1.3
F5	0,04324	-0.2	0,04794	-0.2	0,04462	0.5	0,03800	-1.3
F3	0,34088	75.6	0,04812	-0.2	0,04250	-0.7	0,03792	-1.3
H3	0,04138	-0.7	0,03368	-5.3	0,02896	-8.6	0,03788	-1.3
G2	0,04498	0.2	0,04601	-0.9	0,04494	0.7	0,04006	0.2
D4	0,04762	0.9	0,04940	0.3	0,04564	1.1	0,04122	1.0
G4	0,04696	0.7	0,04964	0.4	0,04450	0.5	0,04318	2.3
C2	0,04432	0.1	0,05107	0.9	0,04400	0.2	0,04282	2.1
C4	0,04272	-0.3	0,05215	1.2	0,03568	-4.7	0,03984	0.0
H1	0,03926	-1.2	0,05175	1.1	0,04046	-1.9	0,04186	1.4
A2	0,04965	1.4	0,05031	0.6	0,04076	-1.7	0,04176	1.3
E4	0,07042	6.7	0,05168	1.1	0,03866	-2.9	0,03888	-0.6
D2	0,04540	0.3	0,05470	2.1	0,04620	1.5	0,04162	1.2
B5*	0,07400	7.6	0,03814	-3.7	0,03226	-6.7	0,03310	-4.6

Table 124.

Tube D				
	Is3/ITS_P			
	ILC1	ILC2	ILC3	ILC4
Total number of data sets	39	39	39	39
Outliers	5	8	8	12
N. of data sets consid. for statistics	34	30	31	27
Degrees of freedom	33	29	30	26
Average	0.86759	0.88632	0.91859	0.70330
Interlaboratory standard deviation	0.11282	0.03978	0.05807	0.03402
CV%	13.0	4.5	6.3	4.8
Minimum	0.63057	0.80818	0.83300	0.64400
Maximum	1.05540	0.96014	1.02680	0.76920
Range	0.42483	0.15196	0.19380	0.12520
Median	0.88884	0.88773	0.91200	0.70260
Repeatability variance	0.0009030735	0.0004610060	0.0003756710	0.0008301333
Interlaboratory variance	0.0125467678	0.0014900036	0.0032964150	0.0009915899
Reproducibility variance	0.0134498413	0.0019510096	0.0036720860	0.0018217232
Confidence interval	0.06762	0.02742	0.03700	0.02809
Minimum confidence limit	0.83378	0.87261	0.90008	0.68926
Maximum confidence limit	0.90140	0.90003	0.93709	0.71735
Reproducibility limit	0.33330	0.12757	0.17478	0.12385

Table 125.

Tube		D						
Integral ratio			Is3/ItSP					
Lab Code	ILC1 Average	ILC1 Z-score	ILC2 Average	ILC2 Z-score	ILC3 Average	ILC3 Z-score	ILC4 Average	ILC4 Z-score
C5	0,88786	0.2	0,87509	-0.3	0,92120	0.0	0,69580	-0.2
E3	78,16394	685.2	0,96014	1.9	0,90140	-0.3	0,73380	0.9
A1	0,98133	1.0	0,96196	1.9	0,93720	0.3	0,76220	1.7
H4	0,90738	0.4	0,94256	1.4	0,97960	1.1	0,76920	1.9
G5	0,87574	0.1	0,86785	-0.5	0,88300	-0.6	0,71780	0.4
B1	0,74055	-1.1	0,81325	-1.8	0,83360	-1.5	0,65360	-1.5
D1	0,85260	-0.1	0,85941	-0.7	0,90760	-0.2	0,67720	-0.8
C3	0,88982	0.2	0,80057	-2.2	0,86020	-1.0	0,79100	2.6
B2	77,12582	676.0	0,88507	-0.0	0,94440	0.4	0,90840	6.0
F4	0,77798	-0.8	0,87088	-0.4	0,91520	-0.1	0,65820	-1.3
D3	1,02096	1.4	0,80818	-2.0	1,02200	1.8	0,79340	2.6
G1	0,90774	0.4	0,84949	-0.9	0,83300	-1.5	0,67520	-0.8
E1	0,91022	0.4	0,90134	0.4	0,90560	-0.2	0,68680	-0.5
E5	0,89784	0.3	0,90366	0.4	0,95080	0.6	0,89160	5.5
B3	0,93036	0.6	0,91777	0.8	0,99160	1.3	0,71000	0.2
A5	0,96346	0.8	0,89920	0.3	1,01120	1.6	0,71040	0.2
A4	0,94296	0.7	0,89920	0.3	1,01120	1.6	0,71040	0.2
H2	0,88236	0.1	0,89126	0.1	0,91200	-0.1	0,74400	1.2
B4	0,66336	-1.8	0,83094	-1.4	0,83460	-1.4	0,70520	0.1
F1	0,63057	-2.1	0,87295	-0.3	0,87420	-0.8	0,69100	-0.4
G3	0,98960	1.1	0,89997	0.3	0,88540	-0.6	0,75480	1.5
D5	0,68560	-1.6	0,81939	-1.7	0,86200	-1.0	0,64400	-1.7
F2	0,72906	-1.2	0,83143	-1.4	0,83320	-1.5	0,65180	-1.5
C1	0,85895	-0.1	0,88469	-0.0	0,90600	-0.2	0,75660	1.6
E2	0,95200	0.7	0,92056	0.9	0,94000	0.4	0,85340	4.4
A3	0,97276	0.9	0,88688	0.0	0,97560	1.0	0,71860	0.4
F5	0,91622	0.4	0,88858	0.1	0,89980	-0.3	0,70240	-0.0
F3	1,05280	1.6	0,86034	-0.7	0,83860	-1.4	0,68080	-0.7
H3	0,69218	-1.6	0,94099	1.4	1,02340	1.8	0,68000	-0.7
G2	0,87388	0.1	0,87580	-0.3	0,90820	-0.2	0,74260	1.2
D4	0,90260	0.3	0,90694	0.5	0,91320	-0.1	0,74200	1.1
G4	0,91444	0.4	0,95379	1.7	0,94460	0.4	0,83080	3.7
C2	0,91184	0.4	0,90814	0.5	0,91660	-0.0	0,73400	0.9
C4	0,68595	-1.6	0,95124	1.6	0,99840	1.4	0,69960	-0.1
H1	0,76164	-0.9	0,93250	1.2	0,92020	0.0	0,70260	-0.0
A2	0,82938	-0.3	0,86939	-0.4	0,86160	-1.0	0,67580	-0.8
E4	0,87456	0.1	0,98230	2.4	1,07740	2.7	0,72760	0.7
D2	1,05540	1.7	0,99998	2.9	1,02680	1.9	0,72640	0.7
B5*	0,26400	-5.4	0,88227	-0.1	0,96800	0.9	0,62980	-2.2

Table 126.

Tube D				
	Is4/ITS_P			
	ILC1	ILC2	ILC3	ILC4
Total number of data sets	39	39	39	39
Outliers	4	9	8	3
N. of data sets consid. for statistics	35	30	31	36
Degrees of freedom	34	29	30	35
Average	1.02061	1.02572	1.06176	1.01497
Interlaboratory standard deviation	0.09174	0.05280	0.07700	0.05988
CV%	9.0	5.1	7.3	5.9
Minimum	0.85612	0.91620	0.90720	0.89320
Maximum	1.23420	1.13331	1.24000	1.14200
Range	0.37808	0.21711	0.33280	0.24880
Median	1.02852	1.02706	1.04800	1.01360
Repeatability variance	0.0012047494	0.0009730150	0.0008641710	0.0012608861
Interlaboratory variance	0.0081757418	0.0025930744	0.0057561989	0.0033330468
Reproducibility variance	0.0093804912	0.0035660894	0.0066203699	0.0045939329
Confidence interval	0.05566	0.03707	0.04969	0.03841
Minimum confidence limit	0.99278	1.00719	1.03692	0.99576
Maximum confidence limit	1.04844	1.0443	1.08660	1.03417
Reproducibility limit	0.27806	0.17247	0.23468	0.19439

Table 127.

Tube		D						
Integral ratio			Isa/ItSP					
Lab Code	ILC1 Average	ILC1 Z-score	ILC2 Average	ILC2 Z-score	ILC3 Average	ILC3 Z-score	ILC4 Average	ILC4 Z-score
C5	1,03624	0.2	1,01806	-0.1	1,07400	0.2	0,99800	-0.3
E3	92,23722	994.3	1,09439	1.3	1,03800	-0.3	1,05000	0.6
A1	1,14173	1.3	1,10954	1.6	1,10200	0.5	1,00340	-0.2
H4	1,05834	0.4	1,09010	1.2	1,14600	1.1	1,10000	1.4
G5	1,00930	-0.1	0,99459	-0.6	1,00840	-0.7	0,99940	-0.3
B1	0,85612	-1.8	0,89208	-2.5	0,90720	-2.0	0,91600	-1.7
D1	0,97494	-0.5	0,97744	-0.9	1,02660	-0.5	0,96400	-0.9
C3	1,02278	0.0	0,80829	-4.1	0,84760	-2.8	1,07200	1.0
B2	97,03806	1046.6	1,03217	0.1	1,09800	0.5	1,11000	1.6
F4	0,97851	-0.5	1,00549	-0.4	1,02860	-0.4	0,98700	-0.5
D3	1,17769	1.7	0,93290	-1.8	1,18600	1.6	1,08600	1.2
G1	1,06582	0.5	1,00206	-0.4	0,99580	-0.9	0,98260	-0.5
E1	1,04986	0.3	1,04048	0.3	1,04800	-0.2	1,03400	0.3
E5	1,05356	0.4	1,05561	0.6	1,10600	0.6	1,14200	2.1
B3	1,04868	0.3	1,05571	0.6	1,17800	1.5	1,02720	0.2
A5	1,07164	0.6	0,99772	-0.5	1,14000	1.0	0,95840	-0.9
A4	1,04858	0.3	0,99772	-0.5	1,14000	1.0	0,95840	-0.9
H2	1,01046	-0.1	1,01886	-0.1	1,04400	-0.2	1,07200	1.0
B4	0,93588	-0.9	0,99392	-0.6	0,99160	-0.9	1,04460	0.5
F1	0,89425	-1.4	1,02982	0.1	1,02660	-0.5	0,97460	-0.7
G3	1,12665	1.2	1,01717	-0.2	1,01340	-0.6	1,01920	0.1
D5	0,86020	-1.7	0,91620	-2.1	0,95840	-1.3	0,89320	-2.0
F2	0,87732	-1.6	0,91848	-2.0	0,91820	-1.9	0,89540	-2.0
C1	0,99891	-0.2	1,03075	0.1	1,05600	-0.1	1,06100	0.8
E2	1,13258	1.2	1,09250	1.3	1,11200	0.7	1,07400	1.0
A3	1,14514	1.4	1,03446	0.2	1,13600	1.0	1,00980	-0.1
F5	1,06178	0.4	1,02430	-0.0	1,04180	-0.3	1,00000	-0.3
F3	1,02090	0.0	0,97811	-0.9	0,96340	-1.3	0,93460	-1.3
H3	0,89123	-1.4	1,13331	2.0	1,24000	2.3	0,95320	-1.0
G2	1,01022	-0.1	1,01251	-0.3	1,04200	-0.3	1,04120	0.4
D4	1,02852	0.1	1,03254	0.1	1,04200	-0.3	1,06200	0.8
G4	1,07336	0.6	1,11886	1.8	1,11400	0.7	1,12600	1.9
C2	1,05622	0.4	1,03953	0.3	1,05840	-0.0	1,03800	0.4
C4	0,86076	-1.7	1,09428	1.3	1,18620	1.6	0,99540	-0.3
H1	0,96862	-0.6	1,06727	0.8	1,06800	0.1	0,99820	-0.3
A2	0,97504	-0.5	1,01109	-0.3	1,01060	-0.7	0,97400	-0.7
E4	1,03102	0.1	1,17186	2.8	1,30200	3.1	1,01740	0.0
D2	1,23420	2.3	1,16516	2.6	1,20400	1.8	1,08800	1.2
B5*	0,28000	-8.1	1,03386	0.2	1,14600	1.1	0,92600	-1.5

Table 128.

Tube D				
	I_{SS}/I_{TSP}			
	ILC1	ILC2	ILC3	ILC4
Total number of data sets	39	39	39	39
Outliers	8	14	13	3
N. of data sets consid. for statistics	31	25	26	36
Degrees of freedom	30	24	25	35
Average	1.22506	1.29466	1.33332	1.36777
Interlaboratory standard deviation	0.31189	0.24753	0.25112	0.23682
CV%	25.5	19.1	18.8	17.3
Minimum	0.30800	0.96922	0.95140	0.98860
Maximum	1.78200	1.78622	1.82000	1.72400
Range	1.47400	0.81699	0.86860	0.73540
Median	1.25069	1.30137	1.30400	1.38100
Repeatability variance	0.0023075685	0.0029006218	0.0037379962	0.0041424306
Interlaboratory variance	0.0968148820	0.0606931314	0.0623140045	0.0552557862
Reproducibility variance	0.0991224505	0.0635937532	0.0660520007	0.0593982168
Confidence interval	0.19226	0.17249	0.17238	0.13811
Minimum confidence limit	1.12893	1.20841	1.24713	1.29872
Maximum confidence limit	1.32119	1.38090	1.41950	1.43683
Reproducibility limit	0.90808	0.73449	0.74709	0.69899

Table 129.

Tube		D						
Integral ratio			Iss/I _{TSP}					
Lab Code	ILC1 Average	ILC1 Z-score	ILC2 Average	ILC2 Z-score	ILC3 Average	ILC3 Z-score	ILC4 Average	ILC4 Z-score
C5	1,09946	-0.4	1,07394	-0.9	1,11600	-0.9	1,11800	-1.1
E3	127,44774	404.7	1,37850	0.3	1,39600	0.2	1,45600	0.4
A1	1,12378	-0.3	1,04919	-1.0	1,12200	-0.8	1,29200	-0.3
H4	1,51314	0.9	1,53271	1.0	1,63000	1.2	1,61400	1.0
G5	1,46522	0.8	1,44628	0.6	1,46800	0.5	1,54800	0.8
B1	1,06317	-0.5	1,07692	-0.9	1,12600	-0.8	1,21400	-0.6
D1	1,03062	-0.6	1,02834	-1.1	1,07400	-1.0	1,12600	-1.0
C3	1,38152	0.5	2,02277	2.9	2,08260	3.0	1,70000	1.4
B2	129,54240	411.4	1,54814	1.0	1,64400	1.2	1,56200	0.8
F4	1,34915	0.4	1,49418	0.8	1,62000	1.1	1,53200	0.7
D3	1,67214	1.4	1,78622	2.0	1,82000	1.9	1,62600	1.1
G1	0,92536	-1.0	0,88241	-1.7	0,89620	-1.7	1,11000	-1.1
E1	1,47188	0.8	1,45697	0.7	1,47600	0.6	1,56000	0.8
E5	1,55050	1.0	1,54226	1.0	1,59600	1.0	1,66800	1.3
B3	1,30134	0.2	1,22337	-0.3	1,04620	-1.1	1,46600	0.4
A5	1,12955	-0.3	1,04067	-1.0	1,22400	-0.4	1,21000	-0.7
A4	1,11309	-0.4	1,04067	-1.0	1,22400	-0.4	1,21000	-0.7
H2	1,44232	0.7	1,45066	0.6	1,48800	0.6	1,61800	1.1
B4	0,86425	-1.2	0,99835	-1.2	1,04860	-1.1	0,98860	-1.6
F1	0,82845	-1.3	1,20807	-0.3	1,31200	-0.1	1,39600	0.1
G3	1,07957	-0.5	0,96922	-1.3	0,98440	-1.4	1,10400	-1.1
D5	0,60480	-2.0	0,66679	-2.5	0,68360	-2.6	0,72100	-2.7
F2	0,90732	-1.0	0,95089	-1.4	0,95140	-1.5	1,05200	-1.3
C1	1,25069	0.1	1,30137	0.0	1,29600	-0.1	1,36600	-0.0
E2	1,57346	1.1	1,51705	0.9	1,52000	0.7	1,64200	1.2
A3	1,42274	0.6	1,26121	-0.1	1,28600	-0.2	1,21600	-0.6
F5	1,54714	1.0	1,50093	0.8	1,52000	0.7	1,28200	-0.4
F3	0,88962	-1.1	0,99841	-1.2	1,00060	-1.3	1,05800	-1.3
H3	0,89795	-1.0	1,47026	0.7	1,68600	1.4	1,01800	-1.5
G2	1,44472	0.7	1,44815	0.6	1,48600	0.6	1,56000	0.8
D4	1,51620	0.9	1,52271	0.9	1,54800	0.9	1,56200	0.8
G4	1,41752	0.6	1,35533	0.2	1,40600	0.3	1,62200	1.1
C2	1,14432	-0.3	1,04846	-1.0	1,08320	-1.0	1,19200	-0.7
C4	0,53807	-2.2	1,70202	1.6	2,03900	2.8	1,03860	-1.4
H1	0,85646	-1.2	1,27646	-0.1	1,33400	0.0	1,02320	-1.5
A2	1,09083	-0.4	1,13949	-0.6	1,14040	-0.8	1,18000	-0.8
E4	0,99396	-0.7	0,62701	-2.7	0,76860	-2.2	1,62400	1.1
D2	1,78200	1.8	1,66513	1.5	1,73600	1.6	1,72400	1.5
B5*	0,30800	-2.9	1,34131	0.2	1,48400	0.6	1,37400	0.0

Table 130.

Tube D				
	Is₆/I_{TSP}			
	ILC1	ILC2	ILC3	ILC4
Total number of data sets	39	39	39	39
Outliers	18	14	11	5
N. of data sets consid. for statistics	21	25	28	34
Degrees of freedom	20	24	27	33
Average	0.33451	0.33707	0.35149	0.28577
Interlaboratory standard deviation	0.03617	0.01665	0.01800	0.02594
CV%	10.8	4.9	5.1	9.1
Minimum	0.24402	0.30758	0.31880	0.23020
Maximum	0.40220	0.38364	0.39540	0.34140
Range	0.15818	0.07606	0.07660	0.11120
Median	0.34724	0.33613	0.35310	0.27600
Repeatability variance	0.0001756206	0.0001043742	0.0003089429	0.0001820118
Interlaboratory variance	0.0012728828	0.0002564668	0.0002622512	0.0006364610
Reproducibility variance	0.0014485034	0.0003608410	0.0005711941	0.0008184728
Confidence interval	0.02857	0.01299	0.01545	0.01668
Minimum confidence limit	0.32023	0.33057	0.34376	0.27743
Maximum confidence limit	0.34880	0.34357	0.35921	0.29411
Reproducibility limit	0.11193	0.05533	0.06923	0.08222

Table 131.

Tube	D							
Integral ratio	Is6/ItSP							
Lab Code	ILC1 Average	ILC1 Z-score	ILC2 Average	ILC2 Z-score	ILC3 Average	ILC3 Z-score	ILC4 Average	ILC4 Z-score
C5	0,34806	0.4	0,34431	0.4	0,36220	0.6	0,27600	-0.4
E3	29,61680	809.7	0,38855	3.1	0,37000	1.0	0,30500	0.7
A1	0,37579	1.1	0,36697	1.8	0,36360	0.7	0,27140	-0.6
H4	0,27350	-1.7	0,36277	1.5	0,37660	1.4	0,28100	-0.2
G5	0,34990	0.4	0,34687	0.6	0,35640	0.3	0,31600	1.2
B1	0,26430	-1.9	0,33455	-0.2	0,35520	0.2	0,29480	0.3
D1	0,33368	0.0	0,33981	0.2	0,36580	0.8	0,27200	-0.5
C3	0,33210	-0.1	0,48722	9.0	0,53460	10.2	0,34440	2.3
B2	24,41484	665.8	0,32393	-0.8	0,35220	0.0	0,31120	1.0
F4	0,24402	-2.5	0,34201	0.3	0,39260	2.3	0,26020	-1.0
D3	0,35114	0.5	0,33759	0.0	0,36760	0.9	0,33340	1.8
G1	0,32222	-0.3	0,29911	-2.3	0,29140	-3.3	0,27100	-0.6
E1	0,34836	0.4	0,34480	0.5	0,34580	-0.3	0,31620	1.2
E5	0,33390	0.0	0,33695	-0.0	0,35800	0.4	0,34140	2.1
B3	0,34728	0.4	0,32316	-0.8	0,26900	-4.6	0,26860	-0.7
A5	0,35483	0.6	0,32651	-0.6	0,36780	0.9	0,27500	-0.4
A4	0,34750	0.4	0,32651	-0.6	0,36780	0.9	0,27500	-0.4
H2	0,34724	0.4	0,35159	0.9	0,36020	0.5	0,30960	0.9
B4	0,30478	-0.8	0,36004	1.4	0,37800	1.5	0,27600	-0.4
F1	0,22444	-3.0	0,31455	-1.4	0,33940	-0.7	0,27480	-0.4
G3	0,37697	1.2	0,33962	0.2	0,32860	-1.3	0,29660	0.4
D5	0,21100	-3.4	0,32167	-0.9	0,34620	-0.3	0,25260	-1.3
F2	0,23098	-2.9	0,32448	-0.8	0,32780	-1.3	0,29020	0.2
C1	0,30705	-0.8	0,31896	-1.1	0,32040	-1.7	0,30600	0.8
E2	0,34642	0.3	0,33613	-0.1	0,34420	-0.4	0,29500	0.4
A3	0,34746	0.4	0,32551	-0.7	0,34540	-0.3	0,24700	-1.5
F5	0,33262	-0.1	0,32456	-0.8	0,33020	-1.2	0,30100	0.6
F3	0,04056	-8.1	0,33095	-0.4	0,31880	-1.8	0,25920	-1.0
H3	0,21107	-3.4	0,30758	-1.8	0,33940	-0.7	0,23020	-2.1
G2	0,33672	0.1	0,33750	0.0	0,35400	0.1	0,31740	1.2
D4	0,34902	0.4	0,35087	0.8	0,35420	0.2	0,32660	1.6
G4	0,33034	-0.1	0,33598	-0.1	0,33980	-0.6	0,31920	1.3
C2	0,34838	0.4	0,34879	0.7	0,35160	0.0	0,27580	-0.4
C4	0,21121	-3.4	0,27065	-4.0	0,30684	-2.5	0,26000	-1.0
H1	0,23134	-2.9	0,35637	1.2	0,35280	0.1	0,26120	-0.9
A2	0,32182	-0.4	0,34768	0.6	0,34420	-0.4	0,26820	-0.7
E4	0,25760	-2.1	0,16375	-10.4	0,17806	-9.6	0,26720	-0.7
D2	0,40220	1.9	0,38364	2.8	0,39540	2.4	0,28840	0.1
B5*	0,09800	-6.5	0,31604	-1.3	0,34300	-0.5	0,21740	-2.6

Table 132.

Tube D				
	Is7/ITS_P			
	ILC1	ILC2	ILC3	ILC4
Total number of data sets	39	39	39	39
Outliers	9	9	8	6
N. of data sets consid. for statistics	30	30	31	33
Degrees of freedom	29	29	30	32
Average	3.00935	2.99099	3.11645	3.30679
Interlaboratory standard deviation	0.24648	0.06704	0.16258	0.15878
CV%	8.2	2.2	5.2	4.8
Minimum	2.34445	2.86959	2.91000	2.99800
Maximum	3.55100	3.16531	3.45600	3.63400
Range	1.20655	0.29573	0.54600	0.63600
Median	3.00810	2.98575	3.07400	3.29000
Repeatability variance	0.0041281032	0.0012543742	0.0044932258	0.0123339394
Interlaboratory variance	0.0599276947	0.0042434267	0.0255332774	0.0227439470
Reproducibility variance	0.0640557979	0.0054978009	0.0300265032	0.0350778864
Confidence interval	0.15711	0.04603	0.10582	0.11085
Minimum confidence limit	2.93080	2.96798	3.06354	3.25136
Maximum confidence limit	3.08790	3.01401	3.16936	3.36221
Reproducibility limit	0.73096	0.21414	0.49979	0.53888

Table 133.

Tube		D						
Integral ratio			Is7/ItSP					
Lab Code	ILC1 Average	ILC1 Z-score	ILC2 Average	ILC2 Z-score	ILC3 Average	ILC3 Z-score	ILC4 Average	ILC4 Z-score
C5	3,13324	0.5	3,05353	0.9	3,19200	0.5	3,24600	-0.4
E3	261,87020	1050.2	2,96265	-0.4	2,98000	-0.8	3,27800	-0.2
A1	3,16448	0.6	2,96271	-0.4	3,12800	0.1	3,29800	-0.1
H4	3,19270	0.7	3,10446	1.7	3,31000	1.2	3,47200	1.0
G5	3,01390	0.0	2,97874	-0.2	2,99600	-0.7	3,29400	-0.1
B1	2,91728	-0.4	2,92269	-1.0	2,95400	-1.0	3,29600	-0.1
D1	2,93014	-0.3	2,90179	-1.3	2,98800	-0.8	3,20200	-0.7
C3	2,88682	-0.5	2,79234	-3.0	2,73200	-2.4	3,56600	1.6
B2	281,42220	1129.5	3,03838	0.7	3,18400	0.4	3,34200	0.2
F4	2,81375	-0.8	3,04526	0.8	3,03400	-0.5	3,13200	-1.1
D3	3,30821	1.2	3,08397	1.4	3,45600	2.1	3,23000	-0.5
G1	3,01782	0.0	2,90170	-1.3	2,96600	-0.9	3,41400	0.7
E1	3,04712	0.2	3,02673	0.5	3,07400	-0.3	3,20800	-0.6
E5	3,05590	0.2	3,03118	0.6	3,10000	-0.1	3,49400	1.2
B3	3,01704	0.0	3,04751	0.8	3,27600	1.0	3,29000	-0.1
A5	3,19562	0.8	2,92181	-1.0	3,45600	2.1	3,57000	1.7
A4	3,12408	0.5	2,92181	-1.0	3,45600	2.1	3,57000	1.7
H2	2,95940	-0.2	2,97262	-0.3	3,04200	-0.5	3,42400	0.7
B4	2,34445	-2.7	2,90870	-1.2	2,91200	-1.3	3,26600	-0.3
F1	2,20167	-3.3	2,95371	-0.6	3,00400	-0.7	3,18000	-0.8
G3	3,30950	1.2	2,99276	0.0	3,09200	-0.2	3,33400	0.2
D5	2,83020	-0.7	2,96875	-0.3	3,06200	-0.3	3,10800	-1.3
F2	2,84264	-0.7	3,01017	0.3	2,99400	-0.8	3,17400	-0.8
C1	2,87099	-0.6	2,95884	-0.5	2,99400	-0.8	3,25400	-0.3
E2	3,22062	0.9	3,11181	1.8	3,10600	-0.1	3,37600	0.4
A3	3,44706	1.8	3,01469	0.4	3,17800	0.4	3,09800	-1.3
F5	3,08424	0.3	2,95760	-0.5	2,99400	-0.8	3,11200	-1.2
F3	0,03232	-12.1	2,86959	-1.8	2,91000	-1.3	2,99800	-1.9
H3	2,58751	-1.7	3,04375	0.8	3,46200	2.1	2,78800	-3.3
G2	2,99034	-0.1	3,00041	0.1	3,03800	-0.5	3,22800	-0.5
D4	3,00230	0.0	3,00947	0.3	3,06000	-0.3	3,63400	2.1
G4	3,14512	0.6	3,20114	3.1	3,28400	1.0	3,43800	0.8
C2	3,22198	0.9	3,06824	1.2	3,19000	0.5	3,54600	1.5
C4	2,63600	-1.5	2,88219	-1.6	3,40400	1.8	2,96000	-2.2
H1	2,88080	-0.5	3,01171	0.3	3,12800	0.1	3,29600	-0.1
A2	2,87143	-0.6	2,90564	-1.3	2,94200	-1.1	3,21400	-0.6
E4	3,20388	0.8	3,16531	2.6	3,67800	3.5	3,19400	-0.7
D2	3,55100	2.2	3,31306	4.8	3,44000	2.0	3,43000	0.8
B5*	0,64400	-9.6	2,71111	-4.2	3,02000	-0.6	2,74000	-3.6

2.7.4 Tube E

Table 134.

TUBE E				
	I _{s1} /I _{TSP}			
	ILC1	ILC2	ILC3	ILC4
Total number of data sets	39	39	39	39
Outliers	12	9	9	3
N. of data sets consid. for statistics	27	30	30	36
Degrees of freedom	26	29	29	35
Average	0.03831	0.03921	0.03716	0.04272
Interlaboratory standard deviation	0.00242	0.00114	0.00161	0.00150
CV%	6.3	2.9	4.3	3.5
Minimum	0.03281	0.03680	0.03386	0.03938
Maximum	0.04412	0.04101	0.04056	0.04560
Range	0.01131	0.00421	0.00670	0.00622
Median	0.03868	0.03906	0.03727	0.04289
Repeatability variance	0.0000029225	0.0000016486	0.0000017709	0.0000048469
Interlaboratory variance	0.0000052575	0.0000009721	0.0000022303	0.0000012814
Reproducibility variance	0.0000081800	0.0000026207	0.0000040012	0.0000061283
Confidence interval	0.00188	0.00100	0.00124	0.00140
Minimum confidence limit	0.03737	0.03871	0.03654	0.04202
Maximum confidence limit	0.03925	0.03971	0.03778	0.04343
Reproducibility limit	0.00830	0.00468	0.00578	0.00710

Table 135.

Tube		E						
Integral ratio		Is/ItSP						
Lab Code	ILC1 Average	ILC1 Z-score	ILC2 Average	ILC2 Z-score	ILC3 Average	ILC3 Z-score	ILC4 Average	ILC4 Z-score
C5	0,03778	-0.2	0,03975	0.5	0,03760	0.3	0,04430	1.1
E3	3,45814	1414.9	0,03774	-1.3	0,03536	-1.1	0,04234	-0.3
A1	0,02822	-4.2	0,04069	1.3	0,03420	-1.8	0,04308	0.2
H4	0,04480	2.7	0,03926	0.0	0,03714	-0.0	0,04560	1.9
G5	0,03688	-0.6	0,03850	-0.6	0,03802	0.5	0,03988	-1.9
B1	0,03992	0.7	0,03860	-0.5	0,03678	-0.2	0,03956	-2.1
D1	0,03554	-1.1	0,03683	-2.1	0,03570	-0.9	0,04162	-0.7
C3	0,03281	-2.3	0,03279	-5.6	0,02731	-6.1	0,04180	-0.6
B2	3,73431	1529.2	0,03729	-1.7	0,03724	0.0	0,04292	0.1
F4	0,04030	0.8	0,03884	-0.3	0,03120	-3.7	0,04340	0.5
D3	0,04167	1.4	0,03885	-0.3	0,04330	3.8	0,04432	1.1
G1	0,03840	0.0	0,03984	0.6	0,03624	-0.6	0,04144	-0.9
E1	0,03970	0.6	0,04013	0.8	0,03800	0.5	0,04336	0.4
E5	0,03950	0.5	0,04041	1.0	0,03796	0.5	0,04358	0.6
B3	0,06682	11.8	0,04086	1.4	0,03922	1.3	0,04494	1.5
A5	0,03455	-1.6	0,03999	0.7	0,04056	2.1	0,04396	0.8
A4	0,03515	-1.3	0,03999	0.7	0,04056	2.1	0,04396	0.8
H2	0,04064	1.0	0,04092	1.5	0,03846	0.8	0,04296	0.2
B4	0,03940	0.5	0,03886	-0.3	0,03730	0.1	0,04202	-0.5
F1	0,03818	-0.1	0,03878	-0.4	0,03690	-0.2	0,04344	0.5
G3	0,03599	-1.0	0,03996	0.7	0,03676	-0.3	0,04184	-0.6
D5	0,03960	0.5	0,03680	-2.1	0,03548	-1.0	0,04276	0.0
F2	0,03772	-0.2	0,03816	-0.9	0,03786	0.4	0,04160	-0.7
C1	0,03879	0.2	0,03846	-0.7	0,03668	-0.3	0,04416	1.0
E2	0,03930	0.4	0,03911	-0.1	0,03924	1.3	0,04286	0.1
A3	0,04412	2.4	0,04254	2.9	0,04022	1.9	0,04176	-0.6
F5	0,03868	0.2	0,04006	0.7	0,03786	0.4	0,04544	1.8
F3	2,29444	933.4	0,03885	-0.3	0,03540	-1.1	0,04122	-1.0
H3	0,04875	4.3	0,03138	-6.9	0,04232	3.2	0,04326	0.4
G2	0,03726	-0.4	0,03891	-0.3	0,03754	0.2	0,04088	-1.2
D4	0,03910	0.3	0,04101	1.6	0,03818	0.6	0,03938	-2.2
G4	0,03800	-0.1	0,03917	-0.0	0,03702	-0.1	0,04366	0.6
C2	0,03512	-1.3	0,03995	0.7	0,03636	-0.5	0,04392	0.8
C4	0,03496	-1.4	0,02991	-8.1	0,03440	-1.7	0,04230	-0.3
H1	0,04080	1.0	0,04083	1.4	0,03516	-1.2	0,04226	-0.3
A2	0,04962	4.7	0,03902	-0.2	0,03386	-2.1	0,04186	-0.6
E4	0,07566	15.5	0,03608	-2.7	0,03140	-3.6	0,04500	1.5
D2	0,03880	0.2	0,03711	-1.8	0,03738	0.1	0,04426	1.0
B5*	0,09000	21.4	0,03079	-7.4	0,02564	-7.2	0,03172	-7.3

Table 136

TUBE E				
	Is2/ITS _P			
	ILC1	ILC2	ILC3	ILC4
Total number of data sets	39	39	39	39
Outliers	11	9	7	5
N. of data sets consid. for statistics	28	30	32	34
Degrees of freedom	27	29	31	33
Average	0.05008	0.05480	0.04970	0.04460
Interlaboratory standard deviation	0.00518	0.00269	0.00247	0.00171
CV%	10.3	4.9	5.0	3.8
Minimum	0.04083	0.04990	0.04408	0.04158
Maximum	0.05678	0.06137	0.05400	0.04826
Range	0.01595	0.01147	0.00992	0.00668
Median	0.05103	0.05469	0.05010	0.04442
Repeatability variance	0.0000040672	0.0000033780	0.0000022910	0.0000033423
Interlaboratory variance	0.0000260263	0.0000065474	0.0000056418	0.0000022728
Reproducibility variance	0.0000300935	0.0000099254	0.0000079328	0.0000056151
Confidence interval	0.00355	0.00196	0.00169	0.00138
Minimum confidence limit	0.04831	0.05383	0.04885	0.04391
Maximum confidence limit	0.05185	0.05578	0.05054	0.04529
Reproducibility limit	0.01589	0.00910	0.00811	0.00681

Table 137.

Tube		E						
Integral ratio		Isz/ItSP						
Lab Code	ILC1 Average	ILC1 Z-score	ILC2 Average	ILC2 Z-score	ILC3 Average	ILC3 Z-score	ILC4 Average	ILC4 Z-score
C5	0,05592	1.1	0,05559	0.3	0,04786	-0.7	0,04654	1.1
E3	3,81684	727.1	0,05450	-0.1	0,04856	-0.5	0,04348	-0.7
A1	0,04471	-1.0	0,05916	1.6	0,04154	-3.3	0,04426	-0.2
H4	0,04708	-0.6	0,06619	4.2	0,05006	0.1	0,04822	2.1
G5	0,05094	0.2	0,05262	-0.8	0,05172	0.8	0,04252	-1.2
B1	0,04751	-0.5	0,05164	-1.2	0,04990	0.1	0,04206	-1.5
D1	0,05049	0.1	0,05223	-1.0	0,04788	-0.7	0,04444	-0.1
C3	0,04092	-1.8	0,05094	-1.4	0,04186	-3.2	0,04320	-0.8
B2	4,34548	829.1	0,05214	-1.0	0,05014	0.2	0,04420	-0.2
F4	0,04360	-1.3	0,05641	0.6	0,04330	-2.6	0,04164	-1.7
D3	0,05382	0.7	0,04990	-1.8	0,05152	0.7	0,04608	0.9
G1	0,05678	1.3	0,05574	0.3	0,04914	-0.2	0,04420	-0.2
E1	0,05450	0.9	0,05471	-0.0	0,05170	0.8	0,04496	0.2
E5	0,05112	0.2	0,05525	0.2	0,05334	1.5	0,04628	1.0
B3	0,07532	4.9	0,05467	-0.0	0,05100	0.5	0,04390	-0.4
A5	0,05655	1.2	0,05999	1.9	0,04454	-2.1	0,04430	-0.2
A4	0,05636	1.2	0,05999	1.9	0,04454	-2.1	0,04430	-0.2
H2	0,05434	0.8	0,05529	0.2	0,05162	0.8	0,04666	1.2
B4	0,04179	-1.6	0,05255	-0.8	0,05038	0.3	0,04442	-0.1
F1	0,04083	-1.8	0,05330	-0.6	0,05054	0.3	0,04500	0.2
G3	0,05404	0.8	0,05665	0.7	0,04948	-0.1	0,04528	0.4
D5	0,04160	-1.6	0,05269	-0.8	0,04744	-0.9	0,04514	0.3
F2	0,04326	-1.3	0,05165	-1.2	0,05066	0.4	0,04160	-1.8
C1	0,05151	0.3	0,05168	-1.2	0,04878	-0.4	0,04642	1.1
E2	0,05242	0.5	0,05499	0.1	0,05400	1.7	0,04496	0.2
A3	0,04920	-0.2	0,05673	0.7	0,04932	-0.2	0,04346	-0.7
F5	0,05082	0.1	0,05582	0.4	0,05130	0.6	0,04778	1.9
F3	0,31726	51.6	0,05435	-0.2	0,04758	-0.9	0,04158	-1.8
H3	0,04951	-0.1	0,03620	-6.9	0,03458	-6.1	0,04336	-0.7
G2	0,05194	0.4	0,05307	-0.6	0,05210	1.0	0,04442	-0.1
D4	0,05448	0.8	0,05635	0.6	0,05286	1.3	0,04562	0.6
G4	0,05334	0.6	0,05466	-0.1	0,05068	0.4	0,04826	2.1
C2	0,05072	0.1	0,05824	1.3	0,04980	0.0	0,04678	1.3
C4	0,03509	-2.9	0,03934	-5.8	0,03122	-7.5	0,03930	-3.1
H1	0,04322	-1.3	0,05666	0.7	0,04408	-2.3	0,04414	-0.3
A2	0,05773	1.5	0,05575	0.4	0,04626	-1.4	0,04514	0.3
E4	0,08212	6.2	0,05697	0.8	0,04402	-2.3	0,04290	-1.0
D2	0,05020	0.0	0,06137	2.4	0,05150	0.7	0,04624	1.0
B5*	0,07600	5.0	0,04521	-3.6	0,03686	-5.2	0,03654	-4.7

Table 138.

TUBE E				
	Is3/ITS _P			
	ILC1	ILC2	ILC3	ILC4
Total number of data sets	39	39	39	39
Outliers	9	12	7	4
N. of data sets consid. for statistics	30	27	32	35
Degrees of freedom	29	26	31	34
Average	0.40371	0.42439	0.42453	0.35466
Interlaboratory standard deviation	0.07357	0.02863	0.02792	0.05008
CV%	18.2	6.7	6.6	14.1
Minimum	0.19400	0.37910	0.37640	0.28560
Maximum	0.58610	0.48993	0.47360	0.48320
Range	0.39210	0.11083	0.09720	0.19760
Median	0.40963	0.42071	0.41980	0.35260
Repeatability variance	0.0001945648	0.0002129189	0.0001821281	0.0011306943
Interlaboratory variance	0.0053736886	0.0007773396	0.0007433643	0.0022818371
Reproducibility variance	0.0055682534	0.0009902585	0.0009254924	0.0034125314
Confidence interval	0.04632	0.02071	0.01828	0.03357
Minimum confidence limit	0.38055	0.41403	0.41539	0.33788
Maximum confidence limit	0.42687	0.43474	0.43367	0.37145
Reproducibility limit	0.21551	0.09131	0.08763	0.16771

Table 139.

Tube		E						
Integral ratio		Is3/ITSP						
Lab Code	ILC1 Average	ILC1 Z-score	ILC2 Average	ILC2 Z-score	ILC3 Average	ILC3 Z-score	ILC4 Average	ILC4 Z-score
C5	0,46928	0.9	0,43937	0.5	0,42040	-0.1	0,33200	-0.5
E3	37,58492	505.4	0,47721	1.8	0,43140	0.2	0,35880	0.1
A1	0,44983	0.6	0,52345	3.5	0,43380	0.3	0,43960	1.7
H4	0,39168	-0.2	0,49962	2.6	0,46900	1.6	0,35660	0.0
G5	0,40472	0.0	0,40396	-0.7	0,41600	-0.3	0,36580	0.2
B1	0,35957	-0.6	0,37910	-1.6	0,38020	-1.6	0,32900	-0.5
D1	0,39709	-0.1	0,40813	-0.6	0,39360	-1.1	0,29740	-1.1
C3	0,43046	0.4	0,45072	0.9	0,43060	0.2	0,43700	1.6
B2	36,19288	486.5	0,41571	-0.3	0,42460	0.0	0,42640	1.4
F4	0,37572	-0.4	0,47689	1.8	0,41400	-0.4	0,29380	-1.2
D3	0,49216	1.2	0,34280	-2.8	0,46200	1.3	0,48320	2.6
G1	0,42768	0.3	0,40326	-0.7	0,37640	-1.7	0,29680	-1.2
E1	0,41698	0.2	0,41635	-0.3	0,41840	-0.2	0,38340	0.6
E5	0,37818	-0.3	0,42331	-0.0	0,44160	0.6	0,46340	2.2
B3	0,45954	0.8	0,42171	-0.1	0,45180	1.0	0,32240	-0.6
A5	0,47765	1.0	0,47019	1.6	0,46900	1.6	0,31760	-0.7
A4	0,46834	0.9	0,47019	1.6	0,46900	1.6	0,31760	-0.7
H2	0,41090	0.1	0,42071	-0.1	0,42040	-0.1	0,39840	0.9
B4	0,31150	-1.3	0,38138	-1.5	0,39200	-1.2	0,35860	0.1
F1	0,32390	-1.1	0,40373	-0.7	0,41980	-0.2	0,31260	-0.8
G3	0,46764	0.9	0,42977	0.2	0,41000	-0.5	0,34760	-0.1
D5	0,31480	-1.2	0,38341	-1.4	0,38400	-1.5	0,28560	-1.4
F2	0,33524	-0.9	0,37944	-1.6	0,39200	-1.2	0,32480	-0.6
C1	0,40836	0.1	0,41459	-0.3	0,41920	-0.2	0,39820	0.9
E2	0,42828	0.3	0,42926	0.2	0,44420	0.7	0,42800	1.5
A3	0,48590	1.1	0,45341	1.0	0,45900	1.2	0,37980	0.5
F5	0,45336	0.7	0,42978	0.2	0,41400	-0.4	0,38560	0.6
F3	0,58610	2.5	0,41309	-0.4	0,39140	-1.2	0,30600	-1.0
H3	0,34108	-0.9	0,46536	1.4	0,49060	2.4	0,30400	-1.0
G2	0,40712	0.0	0,40644	-0.6	0,41920	-0.2	0,39300	0.8
D4	0,41734	0.2	0,42006	-0.2	0,41980	-0.2	0,38940	0.7
G4	0,43238	0.4	0,43992	0.5	0,45020	0.9	0,41020	1.1
C2	0,42166	0.2	0,44160	0.6	0,41620	-0.3	0,31880	-0.7
C4	0,34182	-0.8	0,34494	-2.8	0,39048	-1.2	0,35260	-0.0
H1	0,35022	-0.7	0,45344	1.0	0,40600	-0.7	0,30960	-0.9
A2	0,34556	-0.8	0,43021	0.2	0,40960	-0.5	0,29920	-1.1
E4	0,43682	0.4	0,48096	2.0	0,51200	3.1	0,44780	1.9
D2	0,49220	1.2	0,48993	2.3	0,47360	1.8	0,36700	0.2
B5*	0,19400	-2.9	0,41807	-0.2	0,44120	0.6	0,26120	-1.9

Table 140.

TUBO E				
	Is4/ItSP			
	ILC1	ILC2	ILC3	ILC4
Total number of data sets	39	39	39	39
Outliers	7	12	7	7
N. of data sets consid. for statistics	32	27	32	32
Degrees of freedom	31	26	31	31
Average	0.60666	0.60740	0.62037	0.58192
Interlaboratory standard deviation	0.06122	0.04509	0.04690	0.03663
CV%	10.1	7.4	7.6	6.3
Minimum	0.49440	0.52696	0.52840	0.50220
Maximum	0.73900	0.70731	0.70580	0.65520
Range	0.24460	0.18035	0.17740	0.15300
Median	0.60422	0.60667	0.61370	0.58460
Repeatability variance	0.0004872782	0.0003711831	0.0005737938	0.0004104781
Interlaboratory variance	0.0036503348	0.0019592281	0.0020851486	0.0012594060
Reproducibility variance	0.0041376130	0.0023304112	0.0026589424	0.0016698841
Confidence interval	0.03866	0.03177	0.03099	0.02456
Minimum confidence limit	0.58733	0.59152	0.60487	0.56964
Maximum confidence limit	0.62599	0.62329	0.63587	0.59420
Reproducibility limit	0.18529	0.14008	0.14854	0.11771

Table 141.

Tube	E							
Integral ratio	Is4/ITSP							
Lab Code	ILC1 Average	ILC1 Z-score	ILC2 Average	ILC2 Z-score	ILC3 Average	ILC3 Z-score	ILC4 Average	ILC4 Z-score
C5	0,68368	1.3	0,63872	0.7	0,63040	0.2	0,59420	0.3
E3	56,52534	913.4	0,66992	1.4	0,62440	0.1	0,60000	0.5
A1	0,63967	0.5	0,71435	2.4	0,62920	0.2	0,74480	4.4
H4	0,64676	0.7	0,70359	2.1	0,69520	1.6	0,65020	1.9
G5	0,59130	-0.3	0,58629	-0.5	0,59980	-0.4	0,56740	-0.4
B1	0,53724	-1.1	0,52820	-1.8	0,52840	-2.0	0,50220	-2.2
D1	0,56958	-0.6	0,57829	-0.6	0,56900	-1.1	0,55260	-0.8
C3	0,59046	-0.3	0,61874	0.3	0,60620	-0.3	0,59840	0.5
B2	55,58770	898.1	0,61021	0.1	0,62340	0.1	0,63080	1.3
F4	0,58886	-0.3	0,71628	2.4	0,66640	1.0	0,57240	-0.3
D3	0,72663	2.0	0,52696	-1.8	0,69500	1.6	0,67560	2.6
G1	0,61444	0.1	0,58171	-0.6	0,56420	-1.2	0,54320	-1.1
E1	0,60724	0.0	0,60497	-0.1	0,61140	-0.2	0,58940	0.2
E5	0,57372	-0.5	0,62663	0.4	0,65020	0.6	0,65520	2.0
B3	0,64220	0.6	0,60681	-0.0	0,66700	1.0	0,58180	-0.0
A5	0,66441	0.9	0,64299	0.8	0,68140	1.3	0,56580	-0.4
A4	0,65002	0.7	0,64299	0.8	0,68140	1.3	0,56580	-0.4
H2	0,60298	-0.1	0,61433	0.2	0,61900	-0.0	0,61820	1.0
B4	0,54083	-1.1	0,57916	-0.6	0,59700	-0.5	0,59920	0.5
F1	0,54763	-1.0	0,58723	-0.4	0,62740	0.1	0,57660	-0.1
G3	0,66334	0.9	0,59987	-0.2	0,58900	-0.7	0,57860	-0.1
D5	0,49440	-1.8	0,53303	-1.6	0,54120	-1.7	0,51560	-1.8
F2	0,50342	-1.7	0,52957	-1.7	0,54180	-1.7	0,50580	-2.1
C1	0,59591	-0.2	0,60532	-0.0	0,61580	-0.1	0,62960	1.3
E2	0,65000	0.7	0,64217	0.8	0,66040	0.9	0,61560	0.9
A3	0,71898	1.8	0,64900	0.9	0,67200	1.1	0,61160	0.8
F5	0,66018	0.9	0,61585	0.2	0,60340	-0.4	0,62880	1.3
F3	0,62250	0.3	0,58116	-0.6	0,56860	-1.1	0,52980	-1.4
H3	0,53700	-1.1	0,69101	1.9	0,75240	2.8	0,56500	-0.5
G2	0,59028	-0.3	0,59041	-0.4	0,60600	-0.3	0,58400	0.1
D4	0,60546	0.0	0,60667	-0.0	0,61160	-0.2	0,60000	0.5
G4	0,63392	0.4	0,64234	0.8	0,66300	0.9	0,64260	1.7
C2	0,61008	0.1	0,62301	0.3	0,60760	-0.3	0,59040	0.2
C4	0,51416	-1.5	0,46929	-3.1	0,62482	0.1	0,53960	-1.2
H1	0,56860	-0.6	0,63632	0.6	0,59980	-0.4	0,58800	0.2
A2	0,48076	-2.1	0,60345	-0.1	0,60120	-0.4	0,56660	-0.4
E4	0,63316	0.4	0,71310	2.3	0,79840	3.8	0,58520	0.1
D2	0,73900	2.2	0,70731	2.2	0,70580	1.8	0,62940	1.3
B5*	0,21800	-6.3	0,61476	0.2	0,66760	1.0	0,52020	-1.7

Table 142.

TUBE E				
	I_{ss}/I_{TSP}			
	ILC1	ILC2	ILC3	ILC4
Total number of data sets	39	39	39	39
Outliers	10	10	10	5
N. of data sets consid. for statistics	29	29	29	34
Degrees of freedom	28	28	28	33
Average	0.70581	0.76212	0.77903	0.72945
Interlaboratory standard deviation	0.19066	0.17284	0.17889	0.14464
CV%	27.0	22.7	23.0	19.8
Minimum	0.21200	0.50720	0.42520	0.35640
Maximum	1.03900	1.24152	1.13200	0.95240
Range	0.82700	0.73432	0.70680	0.59600
Median	0.74115	0.76559	0.76540	0.74740
Repeatability variance	0.0018193290	0.0046613533	0.0053079897	0.0040414794
Interlaboratory variance	0.0359869705	0.0289429100	0.0309391956	0.0201123885
Reproducibility variance	0.0378062995	0.0336042633	0.0362471853	0.0241538679
Confidence interval	0.12276	0.11574	0.12020	0.09062
Minimum confidence limit	0.64443	0.70425	0.71893	0.68414
Maximum confidence limit	0.76719	0.81999	0.83913	0.77476
Reproducibility limit	0.56238	0.53021	0.55067	0.44666

Table 143.

Tube	E							
Integral ratio	Iss/I _{TSP}							
Lab Code	ILC1 Average	ILC1 Z-score	ILC2 Average	ILC2 Z-score	ILC3 Average	ILC3 Z-score	ILC4 Average	ILC4 Z-score
C5	0,58182	-0.7	0,55843	-1.2	0,58140	-1.1	0,74920	0.1
E3	71,65580	372.1	0,72468	-0.2	0,76540	-0.1	0,79540	0.5
A1	0,64178	-0.3	0,54497	-1.3	0,63980	-0.8	0,99500	1.8
H4	0,86484	0.8	0,90233	0.8	0,97140	1.1	0,93320	1.4
G5	0,85542	0.8	0,84959	0.5	0,85840	0.4	0,81740	0.6
B1	0,66656	-0.2	0,63835	-0.7	0,65820	-0.7	0,64300	-0.6
D1	0,59412	-0.6	0,59492	-1.0	0,59720	-1.0	0,59660	-0.9
C3	0,80934	0.5	0,70567	-0.3	0,89200	0.6	0,89580	1.2
B2	72,89754	378.6	0,95701	1.1	0,97040	1.1	0,82320	0.6
F4	0,80393	0.5	0,54809	-1.2	0,62620	-0.9	0,79640	0.5
D3	1,02887	1.7	1,24152	2.8	1,13200	2.0	0,95240	1.5
G1	0,55320	-0.8	0,53100	-1.3	0,52560	-1.4	0,63820	-0.6
E1	0,86714	0.8	0,86316	0.6	0,87780	0.6	0,80020	0.5
E5	0,90764	1.1	0,93554	1.0	0,94700	0.9	0,89480	1.1
B3	0,78528	0.4	0,83321	0.4	0,71020	-0.4	0,74560	0.1
A5	0,66809	-0.2	0,60994	-0.9	0,72000	-0.3	0,65980	-0.5
A4	0,66269	-0.2	0,60994	-0.9	0,72000	-0.3	0,65980	-0.5
H2	0,81564	0.6	0,82413	0.4	0,83500	0.3	0,87580	1.0
B4	0,44166	-1.4	0,59803	-0.9	0,59580	-1.0	0,48940	-1.7
F1	0,49701	-1.1	0,76559	0.0	0,67400	-0.6	0,80360	0.5
G3	0,62892	-0.4	0,56422	-1.1	0,57540	-1.1	0,56920	-1.1
D5	0,35380	-1.8	0,39905	-2.1	0,40060	-2.1	0,35640	-2.6
F2	0,48462	-1.2	0,50720	-1.5	0,51900	-1.5	0,52060	-1.4
C1	0,74115	0.2	0,75871	-0.0	0,75440	-0.1	0,73420	0.0
E2	0,93170	1.2	0,90842	0.8	0,90740	0.7	0,87500	1.0
A3	0,78394	0.4	0,74597	-0.1	0,76440	-0.1	0,67460	-0.4
F5	0,98078	1.4	0,97019	1.2	1,01060	1.3	0,73260	0.0
F3	0,43396	-1.4	0,55976	-1.2	0,57640	-1.1	0,52600	-1.4
H3	0,59977	-0.6	0,93253	1.0	1,11780	1.9	0,65620	-0.5
G2	0,84856	0.7	0,85311	0.5	0,86440	0.5	0,78420	0.4
D4	0,86778	0.8	0,86916	0.6	0,87920	0.6	0,83520	0.7
G4	0,80358	0.5	0,77765	0.1	0,77760	-0.0	0,83260	0.7
C2	0,65576	-0.3	0,58916	-1.0	0,60520	-1.0	0,66760	-0.4
C4	0,59614	-0.6	1,25217	2.8	1,49900	4.0	0,63260	-0.7
H1	0,50312	-1.1	0,84568	0.5	0,91380	0.8	0,51600	-1.5
A2	0,48353	-1.2	0,55210	-1.2	0,61280	-0.9	0,66900	-0.4
E4	0,57400	-0.7	0,38225	-2.2	0,42520	-2.0	1,17200	3.1
D2	1,03900	1.7	0,96472	1.2	0,99060	1.2	0,92040	1.3
B5*	0,21200	-2.6	0,72157	-0.2	0,77620	-0.0	0,69960	-0.2

Table 144.

TUBE E				
	Is ₆ /I _{TSP}			
	ILC1	ILC2	ILC3	ILC4
Total number of data sets	39	39	39	39
Outliers	21	9	7	2
N. of data sets consid. for statistics	18	30	32	37
Degrees of freedom	17	29	31	36
Average	0.29557	0.31023	0.31346	0.27042
Interlaboratory standard deviation	0.04203	0.01351	0.01814	0.02427
CV%	14.2	4.4	5.8	9.0
Minimum	0.21228	0.29170	0.27480	0.20680
Maximum	0.33187	0.35040	0.35280	0.32180
Range	0.11959	0.05870	0.07800	0.11500
Median	0.31505	0.30662	0.31230	0.26840
Repeatability variance	0.0000569311	0.0002601116	0.0004755531	0.0003103622
Interlaboratory variance	0.0017551342	0.0001304956	0.0002340564	0.0005270582
Reproducibility variance	0.0018120653	0.0003906072	0.0007096095	0.0008374204
Confidence interval	0.03492	0.01227	0.01601	0.01618
Minimum confidence limit	0.27812	0.30410	0.30545	0.26233
Maximum confidence limit	0.31303	0.31637	0.32146	0.27851
Reproducibility limit	0.12648	0.05708	0.07674	0.08292

Table 145.

Tube		E						
Integral ratio			Is ₆ /I _{TSP}					
Lab Code	ILC1 Average	ILC1 Z-score	ILC2 Average	ILC2 Z-score	ILC3 Average	ILC3 Z-score	ILC4 Average	ILC4 Z-score
C5	0,32424	0.7	0,30459	-0.4	0,30500	-0.5	0,27840	0.3
E3	26,79346	630.5	0,32901	1.4	0,31940	0.3	0,28460	0.6
A1	0,30784	0.3	0,31087	0.0	0,30320	-0.6	0,25400	-0.7
H4	0,27018	-0.6	0,33500	1.8	0,34260	1.6	0,27180	0.1
G5	0,31900	0.6	0,31623	0.4	0,32680	0.7	0,28080	0.4
B1	0,24278	-1.3	0,30622	-0.3	0,31560	0.1	0,26640	-0.2
D1	0,29795	0.1	0,30455	-0.4	0,29880	-0.8	0,26140	-0.4
C3	0,27194	-0.6	0,26444	-3.4	0,31440	0.1	0,28580	0.6
B2	22,03088	517.1	0,29839	-0.9	0,30920	-0.2	0,26500	-0.2
F4	0,21978	-1.8	0,23647	-5.5	0,21502	-5.4	0,24520	-1.0
D3	0,33187	0.9	0,32658	1.2	0,33880	1.4	0,31440	1.8
G1	0,31814	0.5	0,29827	-0.9	0,28220	-1.7	0,25160	-0.8
E1	0,31724	0.5	0,31626	0.4	0,32220	0.5	0,27160	0.0
E5	0,29310	-0.1	0,31840	0.6	0,32980	0.9	0,32180	2.1
B3	0,33096	0.8	0,34276	2.4	0,31300	-0.0	0,24360	-1.1
A5	0,33044	0.8	0,30402	-0.5	0,33800	1.4	0,26680	-0.1
A4	0,32269	0.6	0,30402	-0.5	0,33800	1.4	0,26680	-0.1
H2	0,30582	0.2	0,31194	0.1	0,31560	0.1	0,30140	1.3
B4	0,25104	-1.1	0,32077	0.8	0,32580	0.7	0,27420	0.2
F1	0,21635	-1.9	0,30609	-0.3	0,27480	-2.1	0,26380	-0.3
G3	0,35045	1.3	0,31134	0.1	0,30620	-0.4	0,28840	0.7
D5	0,19260	-2.5	0,29657	-1.0	0,30540	-0.4	0,24620	-1.0
F2	0,21228	-2.0	0,29459	-1.2	0,31040	-0.2	0,26840	-0.1
C1	0,28676	-0.2	0,29170	-1.4	0,29240	-1.2	0,29160	0.9
E2	0,32462	0.7	0,32022	0.7	0,32880	0.8	0,28180	0.5
A3	0,33104	0.8	0,30595	-0.3	0,31420	0.0	0,25780	-0.5
F5	0,30982	0.3	0,29561	-1.1	0,29820	-0.8	0,30720	1.5
F3	0,04780	-5.9	0,29453	-1.2	0,28860	-1.4	0,23780	-1.3
H3	0,17729	-2.8	0,25906	-3.8	0,29800	-0.9	0,20680	-2.6
G2	0,32104	0.6	0,32085	0.8	0,33140	1.0	0,28560	0.6
D4	0,31286	0.4	0,31296	0.2	0,31600	0.1	0,31420	1.8
G4	0,30598	0.2	0,30702	-0.2	0,31080	-0.1	0,30400	1.4
C2	0,31760	0.5	0,31998	0.7	0,31380	0.0	0,27640	0.2
C4	0,16787	-3.0	0,32470	1.1	0,33572	1.2	0,22660	-1.8
H1	0,21606	-1.9	0,31047	0.0	0,30400	-0.5	0,26260	-0.3
A2	0,23658	-1.4	0,29442	-1.2	0,29960	-0.8	0,25540	-0.6
E4	0,21824	-1.8	0,19019	-8.9	0,20434	-6.0	0,24960	-0.9
D2	0,37080	1.8	0,35040	3.0	0,35280	2.2	0,28300	0.5
B5*	0,09400	-4.8	0,26760	-3.2	0,28660	-1.5	0,20620	-2.6

Table 146.

TUBE E				
	Is7/ITS_P			
	ILC1	ILC2	ILC3	ILC4
Total number of data sets	39	39	39	39
Outliers	7	8	11	3
N. of data sets consid. for statistics	32	31	28	36
Degrees of freedom	31	30	27	35
Average	2.30293	2.28198	2.33679	2.51639
Interlaboratory standard deviation	0.17705	0.06563	0.08782	0.12829
CV%	7.7	2.9	3.8	5.1
Minimum	1.90117	2.14288	2.21600	2.17000
Maximum	2.62695	2.44938	2.62600	2.76000
Range	0.72578	0.30650	0.4100	0.59000
Median	2.31319	2.27830	2.33100	2.51600
Repeatability variance	0.0029520463	0.0008336899	0.0023310714	0.0098966667
Interlaboratory variance	0.0307565937	0.0041410689	0.0072461825	0.0144779968
Reproducibility variance	0.0337086400	0.0049747588	0.0095772539	0.0243746635
Confidence interval	0.11035	0.04307	0.06325	0.08847
Minimum confidence limit	2.24776	2.26044	2.30516	2.47215
Maximum confidence limit	2.35811	2.30351	2.36841	2.56062
Reproducibility limit	0.52888	0.20343	0.28350	0.44777

Table 147.

Tube		E						
Integral ratio			Is7/ITSP					
Lab Code	ILC1 Average	ILC1 Z-score	ILC2 Average	ILC2 Z-score	ILC3 Average	ILC3 Z-score	ILC4 Average	ILC4 Z-score
C5	2,50002	1.1	2,35304	1.1	2,43000	1.1	2,49800	-0.1
E3	213,12496	1190.7	2,23758	-0.7	2,26400	-0.8	2,43200	-0.7
A1	2,34267	0.2	2,25133	-0.5	2,34800	0.1	2,51800	0.0
H4	2,49708	1.1	2,43062	2.3	2,57000	2.7	2,68400	1.3
G5	2,30964	0.0	2,27830	-0.1	2,28200	-0.6	2,48600	-0.2
B1	2,42905	0.7	2,24883	-0.5	2,25600	-0.9	2,51400	-0.0
D1	2,22469	-0.4	2,21367	-1.0	2,24400	-1.1	2,37800	-1.1
C3	2,17494	-0.7	2,31305	0.5	2,34800	0.1	2,58200	0.5
B2	214,94180	1201.0	2,31812	0.6	2,34800	0.1	2,60600	0.7
F4	2,19640	-0.6	2,46761	2.8	2,48200	1.7	2,52400	0.1
D3	2,62695	1.8	2,44938	2.6	2,67400	3.8	2,58600	0.5
G1	2,26372	-0.2	2,18151	-1.5	2,23400	-1.2	2,38400	-1.0
E1	2,31660	0.1	2,30768	0.4	2,33800	0.0	2,41200	-0.8
E5	2,30464	0.0	2,36714	1.3	2,40200	0.7	2,73200	1.7
B3	2,32300	0.1	2,32904	0.7	2,43400	1.1	2,50200	-0.1
A5	2,51555	1.2	2,30494	0.3	2,67400	3.8	2,62400	0.8
A4	2,45209	0.8	2,30494	0.3	2,67400	3.8	2,62400	0.8
H2	2,27286	-0.2	2,29326	0.2	2,32800	-0.1	2,68000	1.3
B4	1,90117	-2.3	2,23363	-0.7	2,27200	-0.7	2,51000	-0.0
F1	1,96692	-1.9	2,25607	-0.4	2,33400	-0.0	2,45200	-0.5
G3	2,49147	1.1	2,25046	-0.5	2,31200	-0.3	2,54400	0.2
D5	2,11920	-1.0	2,22564	-0.9	2,27800	-0.7	2,36400	-1.2
F2	2,11914	-1.0	2,25013	-0.5	2,25400	-0.9	2,32200	-1.5
C1	2,22691	-0.4	2,24919	-0.5	2,28400	-0.6	2,56400	0.4
E2	2,44070	0.8	2,37984	1.5	2,38800	0.6	2,58000	0.5
A3	2,61276	1.7	2,35275	1.1	2,47000	1.5	2,43400	-0.6
F5	2,36794	0.4	2,24319	-0.6	2,27000	-0.8	2,66200	1.1
F3	0,03712	-12.8	2,14288	-2.1	2,21600	-1.4	2,26800	-1.9
H3	2,00563	-1.7	2,32783	0.7	2,72400	4.4	2,17000	-2.7
G2	2,30978	0.0	2,32421	0.6	2,34400	0.1	2,48000	-0.3
D4	2,29838	0.0	2,29140	0.1	2,32600	-0.1	2,76000	1.9
G4	2,36818	0.4	2,36623	1.3	2,42800	1.0	2,70000	1.4
C2	2,35222	0.3	2,30801	0.4	2,38200	0.5	2,54400	0.2
C4	2,08375	-1.2	2,08930	-2.9	2,38800	0.6	2,12800	-3.0
H1	2,18600	-0.7	2,24307	-0.6	2,33800	0.0	2,54200	0.2
A2	1,81052	-2.8	2,18706	-1.4	2,36800	0.4	2,46400	-0.4
E4	2,39850	0.5	2,39663	1.7	2,83000	5.6	2,47800	-0.3
D2	2,75980	2.6	2,54313	4.0	2,62600	3.3	2,64800	1.0
B5*	0,55400	-9.9	1,97161	-4.7	2,16800	-1.9	1,99200	-4.1

2.7.5 Final comments

In line with the results reported in the previous chapter, the new data elaboration indicate that the NMR experiment (1D ^1H NOESY) proposed for the fingerprinting of wheat and flour aqueous extracts is a robust experiment. In fact, the majority of the participants produced NMR spectra that can be considered “statistically equivalent”. Thus, the main goal of this interlaboratory comparison, the validation of the 1D ^1H NOESY experiment, was achieved. It is important to point out that laboratory performance assessment is strongly dependent on the operator. It was found that laboratories obtaining unacceptable $|z\text{-scores}| (>10)$ in the first elaboration, ILC1, gained better results in the new elaborations ILC2-4 carried out by a single operator and in many cases their performance were satisfactory. No substantial effects of the software and of the integration procedure were found.

For each signal, considering the average obtained from all laboratories, results were substantially the same, as is possible to see in evidence in figures 62-63.

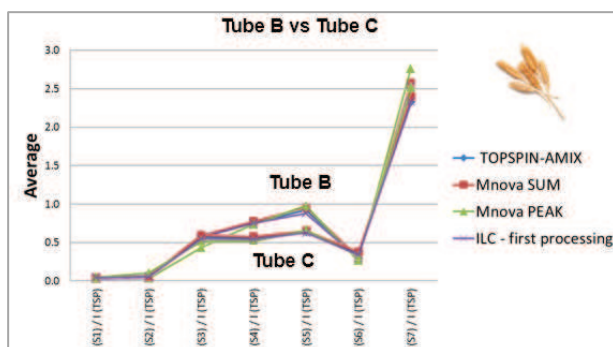

Figure 62..

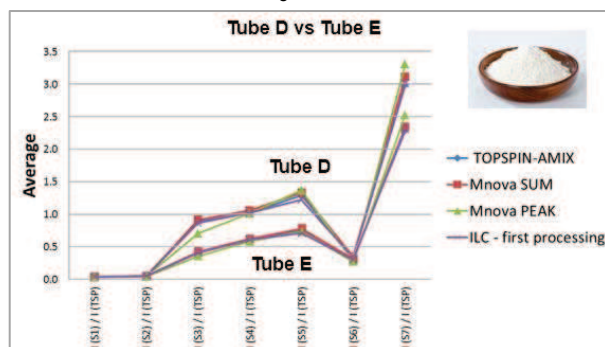

Figure 63.

As a general trend, CV% was lower in the new elaborations ILC2-4 with respect to ILC1 and this can be attributed to the reduction of the casual errors deriving from the processing by many operators. (Gallo et al, 2016)

In line with ILC1, CV% values do not depend on the magnitude of $I_{\text{signal}}/I_{\text{TSP}}$ ratio. As is possible see from figures 64, 66, 68, 70, the signal I_{S3}/I_{TSP} has the same trend in all tubes considering averages, but in CV% graphics gives some high values (Figures 65, 67, 69, 71). Again, the highest CV% values found for all the NMR tubes B-E are related to I_{S5}/I_{TSP} . This was explained with the influence of the pre-saturation radiation acting in close proximity to S5. Little differences in terms of soft pulse calibration, unavoidable in a ILC, can markedly affect the reproducibility I_{S5}/I_{TSP} ratio.

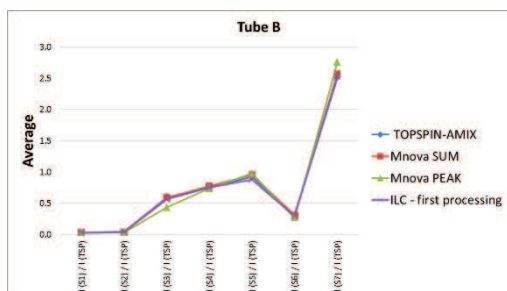

Figure 64.

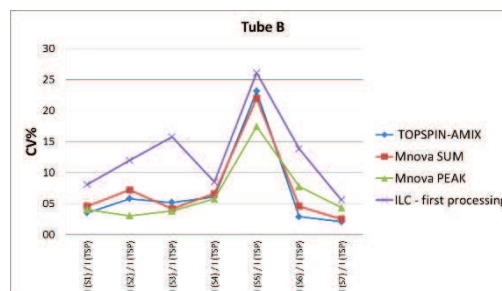

Figure 65.

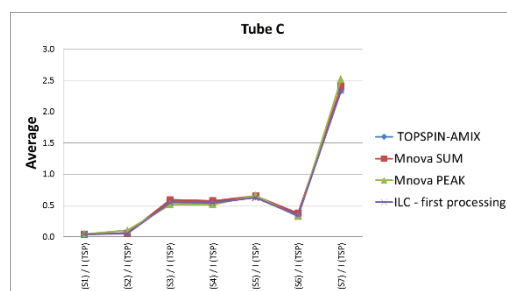

Figure 66.

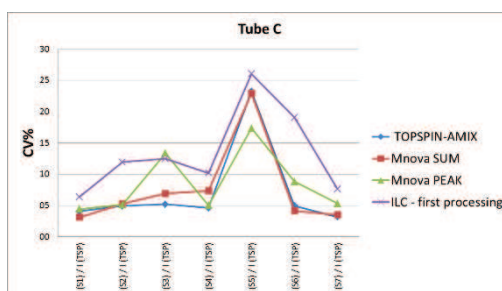

Figure 67.

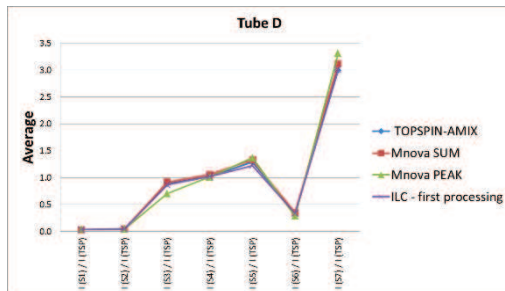

Figure 68.

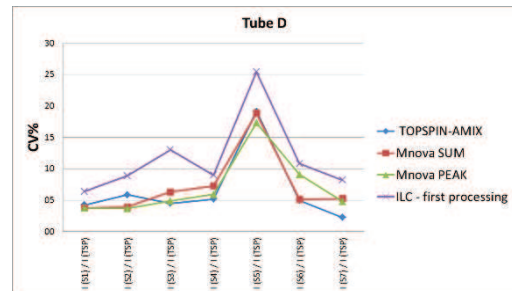

Figure 69.

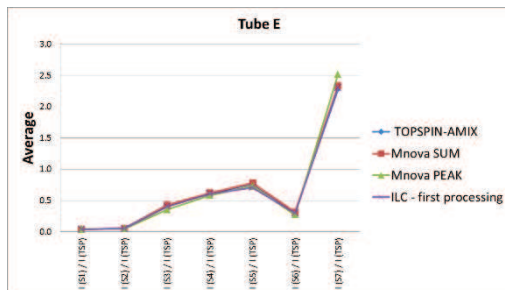

Figure 70.

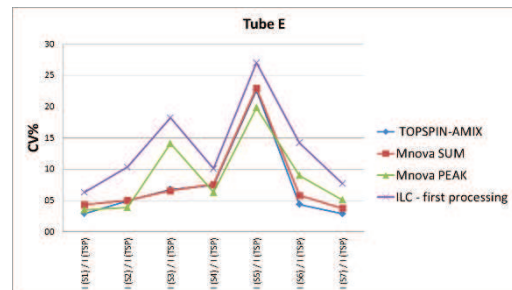

Figure 71.

In general CV% values associated to each signal are rather high, so it will be necessary investigate, in future, in order to understand the reason.

The Fisher test should had give an answer, but it is too much expensive in terms of time, so we decided to perform PCA, that is more fast and equal precise, choosing seven different variables. All samples of wheat and flour were considered for analysis and the bucket table was realized on the entire spectrum. PCA was performed on data and the scores plot shows as samples were grouped in 2 cluster depending on samples.

As shown in figures 72-73 during PCA, considering first 7 variables and than regular bucketing on wheat samples, we have in both cases two different clusters corresponding to B-C sets confirming results shown above. A clear subdivision was observed between samples of wheat. Sample B is grouped in the first and fourth quadrant and sample C in the second and third quadrant.

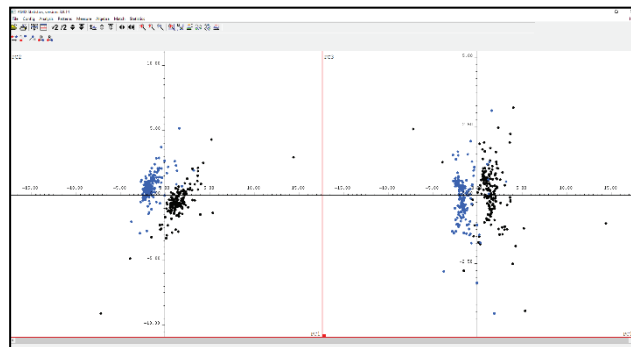

Figure 72. PCA with 7 variables on tubes B (black) and C (blue)

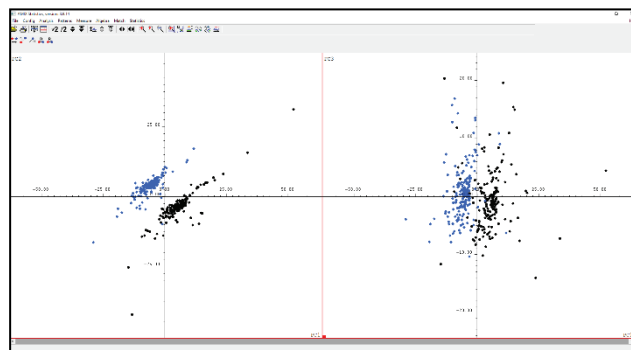

Figure 73. PCA regular bucketing tubes B (black) and C (blue)

The same situation resulted from PCA performed on flour samples D and E: the first sample is grouped in the first and fourth quadrant and second sample in the second and third quadrant. (Figures 74-75)

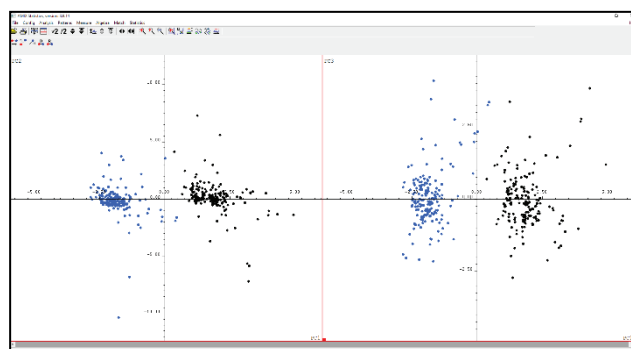

Figure 74. PCA with 7 variables on tubes D (black) and E (blue)

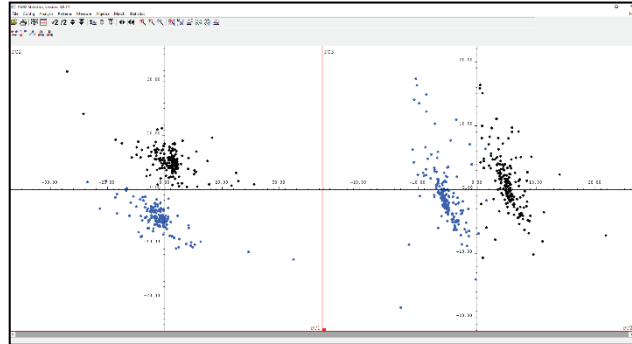

Figure 75. PCA regular bucketing tubes D (black) and E (blue)

So, PCA had confirmed that results depend from samples and not from laboratories

CONCLUSION

3.0 Conclusion

Results presented above indicate that the NMR experiment (1D ^1H NOESY) proposed for the fingerprinting of wheat and flour aqueous extracts is a robust experiment. In fact, the majority of the participants (more than 70 %) produced NMR spectra that can be considered “statistically equivalent”.

Only three laboratories obtained abnormal z-score (parameter used to compare results) very frequently.

For laboratories that obtained both satisfactory and unsatisfactory performances for signals recorded for the same NMR tube, a possible cause for such results might derive either from incorrect phase correction or incorrect baseline correction. It is not excluded a combination of errors in the two correction procedures.

It was found that laboratories obtaining unacceptable |z-scores| (>10) in the first elaboration, gained better results in the new elaborations carried out by a single operator and in many cases their performance were satisfactory. No substantial effects of the software and of the integration procedure were found.

So it is important to point out that laboratory performance assessment is strongly dependent on the operator.

Thus, the main goal of this interlaboratory comparison, the validation of the 1D ^1H NOESY experiment, was achieved along with the indication of the participants able to produce NMR spectra with the highest possible performances.

In conclusion, future ILC using 1D ^1H NOESY experiment should be organized to confirm the results published and to pave the way to validation of NMR experiment on different matrixes.

REFERENCES

4.0 References

Abdi, H., and Williams, L.J. (2010) Principal component analysis

Andreini, P. (1995) Certificare la qualità. Strumenti, metodi e servizi per sistemi aziendali e prodotti. Ed. Hoepli Milano

AOAC Guidelines for Single Laboratory Validation of Chemical Methods for Dietary Supplements and Botanicals (2002)

Baldoni, R., Giardini, L. (2000) Coltivazioni erbacee. Cereali e proteaginose. Patron Editore. Bologna.

Bharti S. K., Roy, R. (2012) Trends in Analytical Chemistry 35, 5-26.

Beleggia, R., Platani, R., Papa, R., Di Chio, A.G., Barros, E., Mashaba, C., Wirth, J., Fammartino, A., Sautter, C., Conner, S., Rauscher, J., Stewart, D., Cattivelli, L. (2011) Metabolomics and food processing: from semolina to pasta. *Journal of Agricultural and Food Chemistry*, 59 (17), 9366-9377

Bloch, F., Hansen, W. and Packard, M. E. (1946) "Nuclear induction" *Physical Review*, 70, 474 -485;

Bonnet, OT. (1966) Inflorescence of maize, wheat, rye, barley and oats: their initiation and development. University of Illinois College of Agriculture, Agricultural Experiment Station, Bulletin 721,100.

Chinnici, G., Pecorino, B. (2008) Le imprese della filiera del grano duro in Puglia. Parte quinta. Dipartimento di scienze Economico-Agrarie ed Estimative - Università degli Studi di Catania.

Claridge, T.D.W. (2009) High Resolution NMR techniques in Organic Chemistry. 2nd edition. Elsevier

Colquhoun, I.L., Lees, M. (1998) Nuclear magnetic resonance for food – Analytical methods for food authentication. Editors Ashurst, P.R and Dennis M.J., London

Decree of Ministry of Agricultural, Food and Forestry Policies "Disposizioni per l'individuazione dei requisiti minimi delle procedure di prelievo di campioni di prodotti bio-

logici da analizzare in attuazione dei regolamenti (CE) n.834/2007, n.889/2008, n.1235/2008 e successive modifiche riguardanti la produzione biologica e l'etichettatura dei prodotti biologici".

Dixon, S.J., Xu, Y., Brereton, R.G., Soini, H.A., Novotny, M V., Oberzaucher, E., Grammer, K., and Penn, D.J (2007). Pattern recognition of gas chromatography mass spectrometry of human volatiles in sweat to distinguish the sex of subjects and determine potential discriminatory marker peaks. *Chemometrics and Intelligent Laboratory Systems*. 87, 161–172.

Food and Agriculture Organization of the United Nations.[Online] 2015. <http://faostat.fao.org/>.

Fellows, H. (1928) Infection of wheat by *Ophiobolus graminis*. *Journal of Agricultural Research* 37 (11)

Findeisen, M., Brand, T. and Berger, S. (2007) *Magnetic Resonance in Chemistry* 45, 175-178

Gallo, V., Scapicchio, P, Vezzoso, M. and Fanizzi, P. (2013) "Risonanza magnetica e controllo qualità – Presentazione dei risultati del primo confronto interlaboratorio nazionale", published by Camera di Commercio, Industria, Artigianato e Agricoltura di Bari, Bari (Italy) ISBN: 978-88-909404-6-0

Gallo, V., Matorilli, P., Cafagna, I., Nitti, G.I., Latronico, M., Longobardi, F., Minoja, A.P., Napoli, C., Romito, V.A., Schafer, H., Schutz, B., Spraul M. (2014) Effects of agronomical practices on chemical composition of table grapes evaluated by NMR spectroscopy. *Journal of Food Composition and Analysis* 35(1), 44-52

Gallo, V., Intini, N., Matorilli, P., Latronico, M., Scapicchio, P., Triggiani, M., Bevilacqua, V., Fanizzi, P., Acquotti, D., Airoldi, C., Arnesano, F., Assfalg, M., Benevelli, F., Bertelli, D., Cagliani, L., Casadei, L., Cesare Marincola, F., Colafemmina, G., Consonni, R., Cosentino, C., Davalli, S., De Pascali, S., D'Aiuto, V., Faccini, A., Gobetto, R., Lamanna, R., Liguori, F., Longobardi, F., Mallamace, D., Mazzei, P., Menegazzo, I., Milone, S., Mucci, A., Napoli, C., Pertinhez, T., Rizzuti, A, Rocchigiani, L., Schievano, E., Sciubba, F., Sobolev, A., Tenori, L., Valerio, M. (2015 a) "Performance assessment in fingerprinting and multi component quantitative NMR analyses" *Analytical Chemistry*, 87, 6709-6717

Gallo, V., Mastrorilli, P., Latronico, M., Intini, N., Scapicchio, P., Cremonini, M. A., Benevelli, F., Milella, A., Rizzuti, A., Cafagna, I. (2015 b) "Validation of a 1D ^1H -NOESY experiment for fingerprinting of wheat and flour", vol. 1 of the series "NMR Interlaboratory Comparisons" Ed. NeP Edizioni, Rome. ISBN 788899 259112

Gallo, V., M., Intini, Mastrorilli, P., Latronico, N., Scapicchio, Milella, A., Rizzuti, A., Todisco, S., Pascazio, A., Triggiani, M., Bevilacqua, V., Cobas, C., Mari, S. (2016) "Validation of NMR fingerprinting methods: effects of processing on measure reproducibility and laboratory performance assessment" vol. 2 of the series "NMR Interlaboratory Comparisons" Ed. NeP Edizioni, Rome ISBN 788899 259709.

Gorter, C. J. (1936). Negative result of an attempt to detect nuclear magnetic spins. *Physica*. 3 (9), 995-998.

Graham, S.F., Amigues, E., Migaud, M., and Browne, R. (2009) Application of NMR based metabolomics for mapping metabolite variation in European wheat. *Springer*. 5 (3), 302-306

Gutowsky, H. S., Kistiakowsky, G. B., Pake, G. E., and Purcell, E. M. (1949) Structural investigations by means of nuclear magnetism. 1. Rigid crystal lattices. *Journal of Chemical Physics*, 17(10), 972-981

Horwitz, W. (1995), *Pure and Applied Chemistry* 67, 331-343

International Grains Council. [Online] 2015. <http://www.igc.int/>

ISO 5725:1994 – Accuracy (trueness and precision) of measurement methods and results, Parts 1-6

ISO 13528:2005 – Statistical methods for use in proficiency testing by interlaboratory comparisons

ISO/IEC Guide 43:1997 Proficiency testing by interlaboratory comparisons

Jacobsen, N. E. (2007). *NMR spectroscopy explained: Simplified theory, Applications and Examples for Organic Chemistry and Structural Biology*. John Wiley & Sons, Inc.

Jackman, L.M and Sternhell, S. (2013) *Nuclear magnetic resonance spectroscopy in organic chemistry*

- Jungnickel, J. L. and Forbes, J. W., (1963) Quantitative measurement of hydrogen types by integrated nuclear magnetic resonance intensities. *Analytical Chemistry*. 35(8), 938-942
- Kavraki, L. (2012). Geometric methods in structural computational biology. Retrieved from <http://cnx.org/content/col10344/1.6/>
- Keeler, J. (2010). *Understanding NMR Spectroscopy*. 2nd Ed. John Wiley & Sons
- Kirby EJM. (1974). Ear development in spring wheat. *Journal of Agricultural Science* 82, 437-447.
- Kirby EJM. (2002). Botany of the wheat plant. [http: www.fao.org](http://www.fao.org)
- Krishnan, P., Kruger, N.J., and Ratcliffe, R.G. (2004) Metabolite fingerprinting and profiling in plants using NMR. *Journal of Experimental Botany* 56.(410), 255-265
- Lamanna, R., Cattivelli, L., Miglietta, M.L. and Troccoli, A. (2011) Geographical origin of durum wheat studied by ¹H-NMR profiling. *Magnetic resonance in Chemistry*, 49 (1), 1-5
- Lin, C., Guo, G., Mennel, D.L. (2008) *Wheat antioxidants*, edited by Liangli Yu
- Manuale UNICHIM 179-1/2001. "Linee guida per la validazione di metodi analitici nei laboratori chimici"
- Marcone, M. F., Wang, S., Albabish W., Nie, S., Somnarain, D. and Hill, A. (2013). Diverse food-based applications of nuclear magnetic resonance (NMR) technology. *Food - research international*, 51, 729-747
- Sacco, A., Neri Bolsi, I., Massini, R., Spraul, M., Humpfer, E., and Ghelli, S., (1998) Preliminary investigation on the characterization of durum wheat flours coming from some areas of south Italy by means of ¹H high resolution magic angle spinning nuclear magnetic resonance. *Journal of Agricultural and Food Chemistry*, 46 (10), 4242-4249
- Sanders, J. K. M. and Hunter, B. K. (1988). *Modern NMR spectroscopy: a guide for chemist*. Oxford University press.

Silverstein, R. M. and Webster, F. X. (2004). Identificazione spettroscopica di composti organici. Casa editrice Ambrosiana.

Smith L.I. (2002) "A tutorial on Principal Components Analysis"

Pacchili, M.T and Bussi, E.(2003). Definire la tracciabilità per garantire la sicurezza alimentare. *L'informatore agrario*. 8, 51-54

Pirouz, D.M. (2006) "An Overview of Partial Least Squares" – The Paul Merage School of Business University of California, Irvine.

Purcell, E.M., Torrey, H.C. and Pound, R.V. (1946) "Resonance Absorption by Nuclear Magnetic Moments in a Solid" *Physical Review*. 69, 37-38.

Regolamento CE n. 178/2002 del Parlamento Europeo e del Consiglio del 28/01/2002 (Gazzetta Ufficiale C.E. L 31 del 01/02/2002)

Thompson, M., Ellison, S. L. R., and Wood, R., (2006) *Pure and Applied Chemistry*, 78, 145–196.

UNI CEI EN ISO/IEC 17043:2010 "General requirements for proficiency testing"

UNI ISO 5725-2:2004. Accuracy (trueness and precision) of measurement methods and results - part 2: basic method for the determination of repeatability and reproducibility of a standard measurement method

Ward, J. L., Baker, J.M., Miller, S. J., Deborde, C., Maucourt, M., Biais, B., Rolin, D., Moing, A., Moco, A., Vervoort, J., Lommen, A., Schäfer, H., Humpfer, E. and Beale, M. H.(2010) An interlaboratory comparison demonstrates that ¹H-NMR metabolite fingerprinting is a robust technique for collaborative plant metabolomic data collection. *Metabolomics*. 6(2) 263-273

Westerhuis, J. A, Hoefsloot, H. C. J., Smit, S., Vis, D.J., Smilde, A.K., Van Velzen, E.J.J., Van Duijnhoven, J.P.M. & Van Dorsten, F.A (2008). Assessment of PLS-DA cross validation. *Metabolomics*. 4 (1), 81–89.

Winnig, H., Viereck, N., Wollenweber, B., Larsen, F.H., Jacobsen, S., Sondergaard I., Engelsen, S. B.(2008) Exploring abiotic stress on asynchronous protein metabolism in single kernels of wheat studied by NMR spectroscopy and chemometrics. *Journal of Experimental Botany*, 60 (1), 291–300.

ACKNOWLEDGEMENTS

5.0 Acknowledgements

First I would like to thank Professor Vito Gallo and Professor Mario Latronico, I am grateful to both my supervisors. They have helped and supported me during these three years of PhD.

I would like to thank to Dr. Isabella Cafagna for teaching me, in the first year, the secrets of nuclear magnetic resonance to metabolomics, for her high availability and for her friendly help.

Thanks to all DICATECh department. I am grateful to Prof. Piero Mastrorilli and to all my colleague: Dr. Antonino Rizzuti, Dr. Matilda Mali, Dr. Valentina Censi, Dr. Stefano Todisco, Dr. Stefania Pontrelli, Dr. Giuseppe Romanazzi, Prof. Gian Paolo Suranna, Dr. Roberto Grisorio, Dr. Maria Michela Dell'Anna, Anna Scardicchio, and Leo Papagni, for their help as well as constructive and inspiring critique.

Furthermore i would like to thank to Carlo Cobas, the President of Mestrelab Research, for give me the possibility to work in his company in Santiago de Compostela, to his fantastic teamwork and to my personal tutor Dr. Silvia Mari, always optimistic and warm person. They were very hospitable and always ready to help me and to solve any kind of problem. My work with them has represented an essential contribution to my thesis.

Thanks also to laboratories from all over the world that allowed us to organize ILCs.

The most important acknowledgement is to family, especially to my parents,. Thanks to my mother for the huge support and encouragement during all my life, and thanks to my father for his availability and for never leaving me alone. Thanks to my boyfriend Michele that, despite differing opinions about this PhD faced without a scholarship, has always believed in me.

CURRICULUM

6.0 Curriculum



Alessandra Milella was born on 07.21.1986 in Bari, Italy
In the same city she attended scientific high school, and she took diploma with 93 /100
In the year 2004, she joined food technologies degree course in “Science, technologies and management of agri-food system” at Faculty of Agriculture of University of Bari.
At 23 years old she obtained a 110/110 bachelor’s degree with praise of Committee and an honorable mention by rector Petrocelli as the best graduate of 2009/2010 session.
She was awarded an international master degree in European Project in 2010, specializing in traceability of food, organized by University of Salento and University of Warsaw in three different cities: first part in Lecce, second part in Warsaw and last part in Brussels, where she worked for Apulia Region in collaboration with European Parliament.
Thereafter in 2014 she started her PhD in Risk and environmental, territorial and building development, curriculum food chemistry at Technical University of Bari. During her PhD she carried out a research period in Mestrelab Research, Santiago de Compostela, Spain. Results of her PhD research are presented in this thesis.