

Innovative Medical Devices for Telemedicine Applications

Agostino Giorgio
*Dipartimento di Elettrotecnica ed Elettronica, Politecnico di Bari, Bari
Italy*

1. Introduction

Telemedicine is a term generally used to describe a type of patient care which involves monitoring of a patient's condition by a healthcare worker located at a healthcare facility which is remote with respect to the location of the patient. Demand for electronic patient monitoring systems will appreciably grow in next years, bolstered by technological advances. Wireless multi-parameter monitors and stations will place gains in equipment sales.

Although telemedicine systems have been implemented for many years, Ethernet has just begun to be implemented in the last decade. A much more cost-effective solution would be to take advantage of the already existing Internet. Moreover, the spread of wireless technology allows the development of more telemedicine devices with a low or no cost connections, at short or long distance, and also wearable and easily portable.

From this point of view, telemedicine is defined as the delivery of health care and sharing of medical knowledge over distance using telecommunication means. Thus, telemedicine aims to provide expert-based health care to understaffed remote sites and advanced emergency care through modern telecommunication and information technologies. This concept of telemedicine was introduced about 30 years ago through the use of nowadays-common technologies like telephone and facsimile machines. Nowadays, telemedicine integrates network and medical technology, generally comprising remote diagnosis, expert consultation, information service, online checkups, remote communication, etc. Based on computers and network communication, it implements remote transfer, storage, query, comparison, display, and sharing of video and audio information and medical data of a patient.

The availability of prompt and expert medical care can meaningfully improve health care services at understaffed rural or remote areas. Then, telemedicine, if adequately employed, is capable of providing enormous benefits to society. One such benefit is that patients can be examined without having to travel to a healthcare facility. This feature is particularly important for patients who live in remote areas who may not be able to easily travel to the nearest healthcare facility, or who need to be examined by a healthcare worker located far away from the patient, in another State, for example. Another benefit of telemedicine is that it is capable of allowing a patient to be examined more often than would be possible if the patient were required to travel to a healthcare facility due to the ease with which it can be administered.

The only drawback of telemedicine is the risk to dramatically reduce the human contact and the feeling between the patient and the doctor which is the fundamental behind the success of any therapy.

In the chapter are described some of innovative devices invented by the author, patented or patent pending, employing the most advanced information and communication technologies, to show the enormous potential of telemedicine.

2. A remote health monitoring system

The effective and modern health monitoring system as that described in this section, designed and patented by the author (Giorgio, 2009), is a system intended to bring about innovation in remote health monitoring in terms of simplicity, economy and effectiveness in both domestic and hospital applications. It also aims at allowing real-time rescue operations in case of emergency without the necessity for data to be constantly monitored by a practitioner.

Its special management software enables a practitioner or other person authorized to monitor any number of patients simultaneously leaving them free to move, as well as to create and manage an electronic case sheet for each of them.

The system thus conceived meets the needs of both patients and their families. It can be suitably used in hospitals, nursing and care homes, and might be useful not only to GPs but also to sportsmen.

2.1 The concept and the functions

The system is designed for both Bluetooth/Zig Bee (wireless, short-distance) monitoring and UMTS/GPRS (wireless, long-distance) monitoring and data transmission. The Bluetooth-based version also allows to monitor a patient at any distance provided that he/she has a mobile phone with Bluetooth interface.

The system collects data relevant to the health status continuously. These are stored in an on-board flash memory and analysed real-time with an automatic diagnosis program.

Data can be transmitted in the following modes:

- a. real time continuously;
- b. real time not continuously as follows:
 - i. at programmable intervals (for 30 seconds every hour, for example);
 - ii. automatically, when a danger is identified by the on board alarm system (explained later);
 - iii. on demand, i.e. whenever required by the monitoring centre;
- c. offline (not real-time), i.e. by downloading previously recorded (over 24 hours, for example) data to a PC.

In all cases patients do not need to do anything but supply power by simply switching on.

The monitored parameters are: electrocardiogram (and then heart frequency); respiratory frequency; body kinetics (activity of the patient); body temperature; oxygen saturation of haemoglobin (SpO₂); environmental pressure, temperature and humidity; position (by GPS); arterial pressure; blood glucose, not invasively measured.

Each monitored patient is given a case sheet on a Personal Computer (PC) functioning as a server (online doctor). Data can also be downloaded by any other PC, handheld or smartphone equipped with a browser. The system reliability rests on the use of a distributed server environment, which allows its functions non to depend on a single PC and gives

more online doctors the chance to use them simultaneously. Its functioning scheme is presented in Figure 1. The whole system consists of three units:

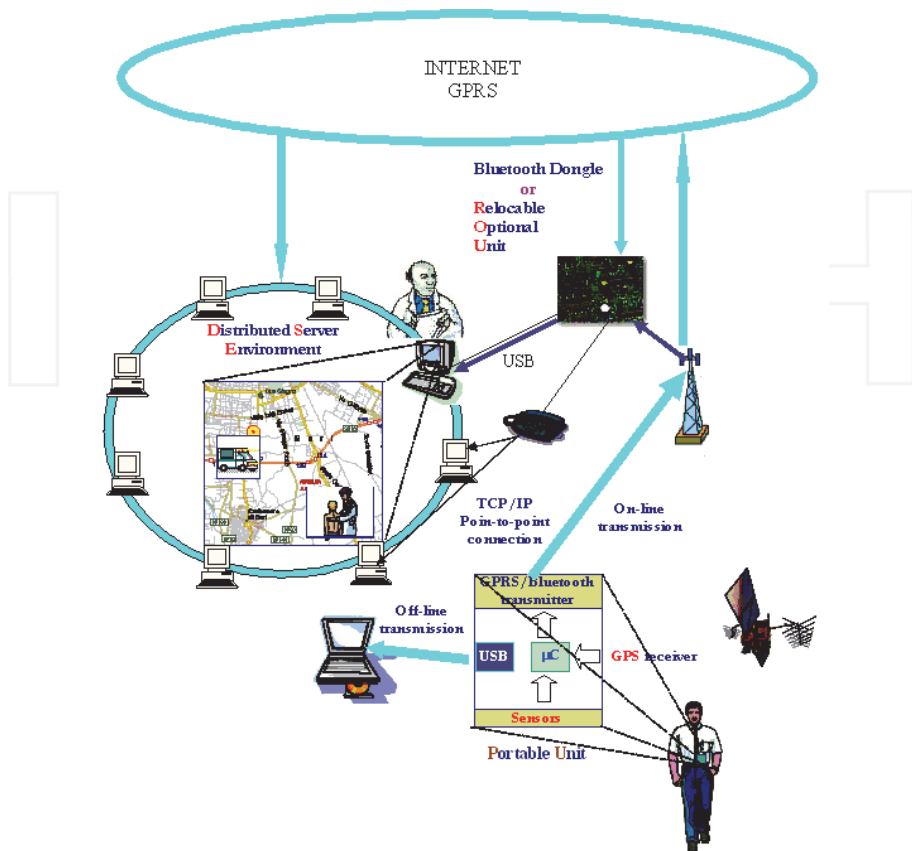

Fig. 1. Functioning scheme of the remote health monitoring system

1. Sensor unit: includes the sensors for the measurement of health parameters and their analog interfaces. The sensors are partly embedded in an elastic band to be round the patient’s chest and partly are posed on the patient body;
2. Portable remote transmission unit (PU), miniaturized and wearable. It is designed for both real-time and delayed data transmission (high-speed USB connection to the server) to the patient’s case sheet.

The main features of the PU are: 16 analog channels; wireless and wireline transmission capability; GPS location system on-board; automatic real-time diagnostic system; electronic alarm service (automatic sending of warning SMS messages); on-board memory for 24 hours recording and USB port for (offline) data transfer to PC ; rechargeable battery-operated.

3. Relocable Optional Unit, ROU, for local transmission and reception: it ensures system reliability by replacing the PC server when it is out of order. The ROU communicates with the PU by simulation of a point-to-point connection via UMTS/GPRS. It can be

connected via USB to the PC server for on-demand data transmission. This unit is also equipped with an embedded modem which allows a real TCP/IP point-to-point connection to other remote PCs for data transfer when the server is out of order. The unit for Bluetooth transmission simply consists of the Bluetooth dongle.

The whole system is governed by a management software. The main operations it performs are:

GPS real-time location of the patient (city, street, number) and address- and phone-number-searching of the nearest first-aid stations; simultaneous monitoring of many patients; remote (computerized) medical consultation service; creation and management of electronic case sheets accessible on Internet by login and password.

The PU monitors the patient's health status storing data in the on-board memory. Data can be sent to the local receiver, directly to the PC server (online doctor), or to an internet server, which allows anyone to download them by his/her own login and password.

As above mentioned, data transmission can be performed at regular intervals or on the online doctor's demand and because of the detection of any warning sign through the electronic diagnosing system.

The block diagram of the PU is shown in figure 2.

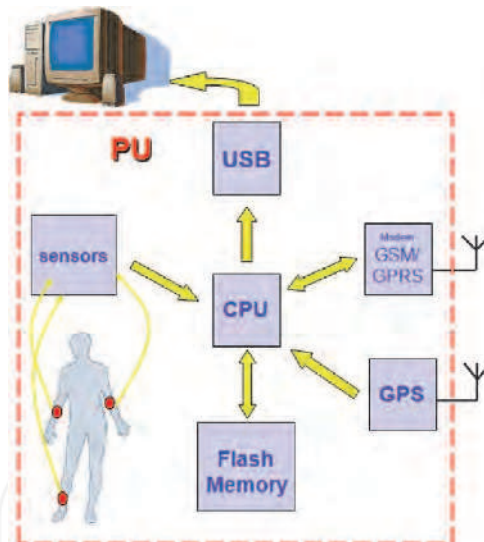

Fig. 2. PU block diagram

In order to ensure the highest levels of security and autonomy, the ROU is also directly connected to the common telephone network: this allows it to keep all its functions even if the server is off or broken down. In fact, a direct call by internal modem allows data transfer to any remote PC.

ROU operates in two modes:

- *Normal mode*: the unit can be used connected to a PC for the transmission on demand.
- *Emergency (alarm) mode*: the unit behaves as a server: it receives the warning signal by the PU and downloads the data transmitted by the PU by GPRS, sending them to the connected PC via USB or to a remote PC by dial-up modem, via telephone cable.

In figure 3 the block diagram of the ROU is shown.

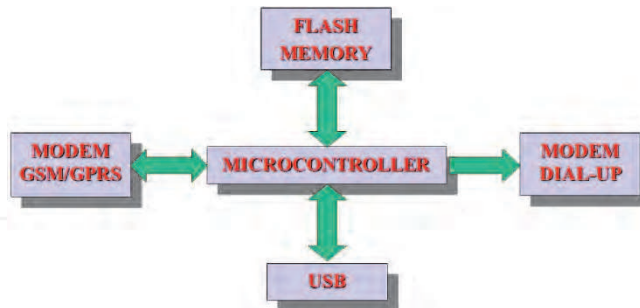

Fig. 3. ROU hardware block diagram

2.2 Example of system operation

The data for the monitoring of the subject's health status are acquired by the remote unit (PU) through sensors which are partly attached to the body, partly to the board. Data are then stored in an embedded flash memory, ready to be transmitted to the ROU or directly to the server PC where the management software has been installed, or to any Internet provider where they can be accessed with permission by login and password.

Data acquisition through the remote PU is immediately followed by an automatic real-time diagnosis performed by the microcontroller of the PU itself.

When a danger is detected the system not only automatically sends a warning SMS message to pre-registered people (doctors, relatives) who are able to arrange for the patient's rescue, but also transmits all data acquired since the detection and the coordinates (GPS mapping) of the subject's position. If the server PC is out of order data are acquired by the ROU or directly sent to a pre-set Internet Provider from which they can be downloaded by any other PC. This accounts for the high system reliability.

The alarm system also includes the automatic GPS location of the patient. Once he/she has been found the management program proceeds to map his/her position thereby indicating the name of the place and the nearest street number as well as the address and telephone number of the nearest hospitals. All these functions do not require any human intervention and are automatically operated only a few seconds after the detection of a danger. Fig.4 shows an example of GPS mapping with the above mentioned informations for a prompt rescue.

The alarm system can be deactivated at any time, whenever the user wishes to stop SMS sending and GPS mapping.

Data can also be transmitted on demand ("ON DEMAND" mode) to the monitoring centre or to any authorized person (i.e. anyone who has been given a login and password). This mode allows the user to fully control the PU through his/her PC. Thereby he/she is not only able to request data transmission at any time, but also to choose the parameters to be transmitted and to deactivate/reset the alarm system.

All "on line" functioning modes enable to set a data acquisition profile peculiar to each patient through the server PC of the monitoring centre.

The management software is also designed to display graphs and maps on handhelds, smartphones and Linux-based PCs.



Fig. 4. Location of the patient and the nearest first-aid station

2.3 Diagnostic equipment

2.3.1 ECG and heart frequency monitoring

An electrocardiogram (ECG) is a recording of the electrical activity on the body surface generated by the heart (Carr & Brown, 2001). ECG measurement is performed by skin electrodes properly placed on the body. The ECG signal is characterized by six peaks and valleys labeled with successive letters of the alphabet P, Q, R, S, T, and U (see Figure 5). Each segment between two letters or piece of wave is due to a particular step of the heart cycle and therefore we distinguish among the P wave, the QRS complex, the ST-T segment, the T wave, the QT interval, the U wave. All these waves must have specific characteristics in terms of shape and time extension; different values far from the appropriate ones are symptoms of cardiac diseases.



Fig. 5. Typical ECG wave period

The front end of an electrocardiograph must be able to detect extremely weak signals ranging from 0.5 mV to 5.0 mV, combined with a dc component of up to 300 mV—resulting from the electrode-skin contact—plus a common-mode component of up to 1.5 V, resulting from the potential between the electrodes and ground. The useful bandwidth of an ECG signal, depending on the application, can range from 0.5 Hz to 50 Hz—for a monitoring application in intensive care units—up to 1 kHz for late-potential measurements and pacemaker detection. A standard clinical ECG application has a bandwidth of 0.05 Hz to 100 Hz. 10 electrodes needs to detect the 12-lead electrocardiogram. This implies a serious inconvenience for the monitored patient to be free to move.

To solve this problem the remote health monitoring system is equipped with an electrocardiograph that measures body cardiac potentials by using only 5 electrodes placed on the chest (see figure 6) and implements an algorithm able to mathematically reconstruct very accurately all 12 leads. This method is named EASI 12-Leads and was proposed for the first time in 1988 by Gordon Dower (Dower, 1988).

In figure 6 the position of the electrodes is shown to detect the potentials V_I, V_S, V_E, V_A , all referred to the potential V_N . Then, the generic cardiac potential V_i can be calculated by means of the following vectorial relation:

$$V_i = a_i V_{ES} + b_i V_{AS} + c_i V_{AI} \tag{1}$$

where a_i, b_i, c_i are constants and V_{xy} denotes the potential difference $V_x - V_y$.

In table 1 are listed the coefficient values allowing to determine each of the 12 derivations:

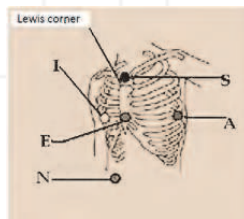

Fig. 6. Position on the chest of the 5 electrodes for the EASI ECG

lead	a_i	b_i	c_i
V_I	0.026	-0.174	0.701
V_{II}	-0.002	1.098	-0.763
V_{III}	-0.028	1.272	-1.464
aV_F	-0.012	-0.462	0.031
aV_R	0.027	-0.723	1.082
aV_L	-0.015	1.185	-1.114
V_1	0.641	-0.391	0.080
V_2	1.229	-1.050	1.021
V_3	0.947	-0.539	0.987
V_4	0.525	0.004	0.841
V_5	0.179	0.278	0.630
V_6	-0.043	0.431	0.213

Table 1. Coefficients useful to determine the 12 derivations of the standard ECG by the EASI ECG

The EASI ECG front end consists of an instrumentation amplifier together with an integrator (low frequency - 0.05 hz - noise filter) and an active low pass filter (for limiting the bandwidth - 40 hz - and the amplitude of the signal) that are the building block for each channel of the electrocardiograph. The right led driving circuit is used to remove the common mode voltage.

The heart frequency is calculated from the ECG signal by evaluating the distance between QRS complex.

2.3.2 Blood glucose monitoring

It is well known that high values of blood glucose can indicate serious illnesses, such as diabetes, which in the long-term can produce several complications affecting many body tissues and organs.

Non-invasive glucose monitoring based approaches are very attractive, particularly for patients which require frequent measurements without any inconvenience (Caduff et al, 2003). There are several methods which are based on non invasive approaches. The most interesting technologies are the 1) near infrared light (NIR) spectroscopy, 2) far infrared radiation (FIR) spectroscopy, 3) reverse iontophoresis, 4) optical rotation of polarized light, 5) impedance spectroscopy. Each method has technical problems to overcome.

The measurement of the glucose concentration can be made only indirectly, by measuring the AC conductivity change which is related to the blood's glucose levels (Hayashi et al, 2002). This conductivity variation affects the electric polarization of cell membranes, thus resulting in the skin permittivity change.

In order to not lose the sensitivity to this effect, we must choose a working frequency not greater than 200 MHz. At the same time, the working frequency has not to be too low in order to avoid the electrode polarization.

Then, our approach for monitoring the glucose level changes makes use of an AC analysis of the skin impedance over a wide frequency range, which is scanned until the optimal frequency, corresponding to the best sensitivity, has been reached. The sensor design has been optimized to work in frequency range 1-200MHz, in which the best performances in terms of electrical changes in the blood can be provided.

The general scheme of our sensor is shown in figure 7.

The sensor evaluates the glucose level by comparing a sine signal with the same signal passed through the passive filter constituted by the skin impedance and the resistor R. The skin impedance, which depends on the glucose concentration, is calculated by the following, well known, voltage divider based relationship in equation (2):

$$z = R \frac{V_1}{V_2 - V_1} \quad (2)$$

The above calculation has to be made for several values of frequency in the range 1-200MHz, in order to evaluate the impedance minimum which provides the best sensor sensitivity. To investigate this wide frequency range a suitable voltage controlled oscillator (VCO) has been employed to provide a sine signal with a high linearity. The output signal, coming from the impedance evaluation block, can be processed by the microcontroller which finds the minimum frequency and stores it in a semiconductor memory. The general scheme is, then, constituted by an analog part, which provides the high frequency sine signal, and a digital section which processes this signal.

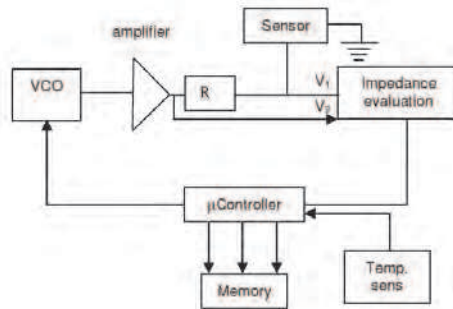

Fig. 7. Block diagram of the impedance spectroscopy based blood glucose sensor

The equation (2) can be easily solved in log forms. To this purpose, the impedance evaluation block is constituted by two differential and two logarithmic amplifiers, as shown in Figure 8:

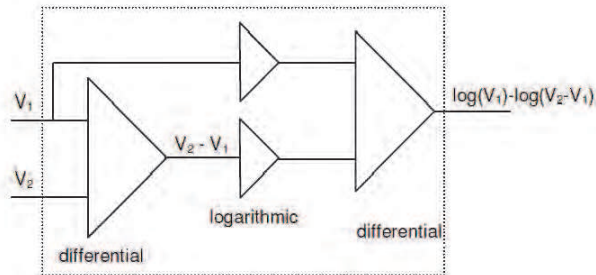

Fig. 8. Block diagram of the impedance evaluation circuit

The VCO has to produce a sine function with a frequency changing in a wide range. The sensor makes continue noninvasive blood glucose monitoring and is more comfortable than other solutions for patients which require frequent measurements without any pain. The device is constituted by commercial integrated circuit and is, then, compact, light and easily wearable.

2.3.3 Physical activity (body kinetics) monitoring

In the meanwhile health status is monitored it is very important to know the activities the patient is performing. For example consider how could be different the meaning of an high heart rate whether the subject is running or standing or let's think about how everyday activities such as climbing stairs could "normally" modify heart frequency and/or breathing rate.

For this reason, to make the diagnosis as accurate as possible, the remote health monitoring system includes appropriate sensors for body kinetics monitoring. To this aim we use an accelerometer.

In fact we observed that root mean square (r.m.s.) values of acceleration (passed through a high pass filter) is fully correlated with walking speed. Experimental data show that vertical acceleration on the shoulder of a running patient peaks from -1g to 2g, while power spectrum spans up to 20Hz. Peaks comes from each impact of foots on ground.

This signal includes a contribute coming from the gravity that is $g\cos\theta$ where θ is the angle between the sense direction of the accelerometer and the gravity. The angle θ is not constant at all when the accelerometer is fixed on the clothes of a patient, and varies widely when a subject bows or stand up. Fortunately the power spectrum of θ is concentrated at frequency below 1Hz (typical), much lower than the frequencies of the acceleration of a walking (running) patient. In conclusion it's necessary and also enough to use a high pass filter to cut off the gravity.

Then, the signal maximum amplitude is $+2g$ (20 m/s^2) and the maximum frequency is 20 Hz. The accelerometer must be high precision (i.e. 0.5mg @ 20Hz) and low power (i.e. $700\mu\text{A}$ @ 5Volt).

The acquisition signal chain is quite simple, it requires a band pass filter to cut off low frequencies at 0.7Hz (related to gravity) and high frequencies at 20Hz to clean unforeseen unwanted signal outside the signal band. Then, the filtered signal pass to a cheap and effective r.m.s. converter. The r.m.s. converter output is filtered to cut off frequencies over 0.1Hz to kill off the residual ripple observed on running patients.

The analog filter signal is clean and spanned voltage range is matched to input span of the ADC of the portable unit.

In figure 9 it is shown the plot of the output of the physical activity monitoring equipment during a running (upper plot) and during a walking (lower plot).

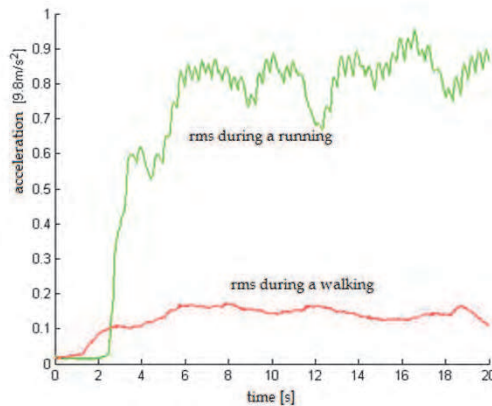

Fig. 9. Plot during a running (the upper one) and during a walking (the lower one)

This kinetic sensor has been tested on several subjects, for each patient it was clearly possible to recognized whether the subject was standing, walking or running.

The observed signal is correlated to the physical activity but also to the weight of the subject, and (we suppose) also the way subject walks. For simple qualitative analysis this is not a problem, if a quantitative analysis were required then a subject by subject calibration would be used, or more simply a statistical parametrization of calibration on some biological parameter (weight, height, sex, age).

With this calibration, we hope that this physical activity measurement would allow a also good quantitative estimator of the energetic expenses to what concern walking and running, and we hope that (using also other biological parameters to evaluate basic metabolism) could be possible to estimate the daily energetic expenses.

This would be very interesting since available method that measure the CO₂ (with mouth and nose tubing,) and the heat production (in a calorimetric box) are not suited for 24 hour measurements and long time monitoring.

2.3.4 Breathing frequency monitoring

For breathing sensing we use an already known method involving a belt to sense the thorax dilatation, but we apply a new kind of belt dilatation sensor on the belt. We sense the resistance changes of the rubber due to stress elongation, the voltage drop on the rubber is amplified (suppressing the DC component).

As much as we know the application of the conductive rubber is new in breathing detection, it is quite cheap and sensitive.

In literature it is possible to find two main methods for breathing monitoring (Webster, 2009). In the first one, the air flow is sensed while in the second one the breast dilatation is sensed.

Air flow monitoring is accurate but is very uncomfortable, since it requires tubing mouth and nose or placing sensors in mouth and in nose. This would rule out 24 hours logging. For remote health monitoring system we are so forced toward the breast dilatation monitoring. This may be quite less accurate, it is sensitive to arms movements but it is much more comfortable.

For breast dilatation monitoring, piezoelectric strain gauge sensor are quite problematic, since the charge generated at typical breathing frequencies (0.25Hz) are difficult to amplify. Accelerometers are not suitable, because the tiny acceleration available (about 0.02g) compares with the gravity acceleration. But the situation is even worse since the accelerometer only sees the vertical component of the gravity, that is $g\cos\theta$ (where θ is inclination angle of the patient), that could vary largely with times comparable with respiration times according to the variations of the angle θ when patient bows. Breast dilatation monitoring is well accomplished using a breast elastic belt, so sensing the belt stress makes it possible to sense breathing.

Aside from several stress sensor we have designed a new, very interesting conductive rubbers sensor, being it also quite cheap and easy tailored. Conductive rubbers are made mixing carbon or iron powder in the chemical reactants used to produce rubbers. They have been applied as flexible conductors and as pressure sensors, but we did not found application as dilatation sensors. Indeed conductivity of these rubbers are sensitive to stress, but among the large kind of conductive rubbers available, not all are suited for this application.

We look for conductive rubber satisfying the following specifications: high sensitivity to the stress; rubber should stand the stress applied to the breast belt, about 10N; moderate conductivity, between 0.1 Ω m and 10 Ω m.

After performing a great number of tests on various kinds of conductivity rubber we chose a sample of conductive rubber from Xilor, whose resistivity was only 7.10⁻⁵ Ω m, constituted by an aggregate of small conductive spheroids, about 20 μ m wide. The conductivity is controlled by the contact surface area between spheroids, this area varies according to the mechanical stress, so that resistivity is high sensitive to the mechanical stress.

We took a sample 120mm long, 20mm large and 0.3mm thick that was fit in the breast belt, at the place of a piece of belt. Since the sample is not capable to stand all the belt stress, it is not feasible a full belt built only with this kind of conductive rubber. To solve this problem, a non conductive rubber was added in a mechanical parallel to our conductive rubber.

Two couples of small iron plates where tightened to each end of the rubbers sandwich to ensure electrical connections.

The resistance of conductive rubber is about 1Ω , measured with the four wires method.

While the breathing rate ranges from about 0.1Hz to 3Hz but the breast movement spectrum has more power in the range from about 0.4Hz to 3Hz, the front end amplifier is connected to the sensor through a capacitor with a low frequency cut off at 0.4Hz, while another capacitor produces upper a cut off at 3Hz.

The dilatation signal after the front end was clear, but it is sensitive to arms movements. After the first amplification stage, signal went through more stages: a peak detection, a pulse shaper and a frequency to voltage converter.

As shown in figure 10, the resulting signal is clear and noiseless; it is also shown the signal from the peak detector which is well behaved.

As already said, the system has been successfully tested on a wide breathing rates interval, but still remain the ageing problem.

Indeed the rubber resistivity raised tenfold after few hour of usage on the belt. While this could be compensated with an automatic gain control at the front end amplifier, much better would be to use the compression method.

A second problem is the sensibility to the arms movements, which could trigger false breathing pulses. This is intrinsic to the belt method, but the effect is not so frequent compared to the breathing rate.

In conclusion, our sensor has been successfully tested, the remaining problems are minor. Anyway, it is recommended to look for other kind of conductive rubbers, cheaper or with better ageing to further improve performances.

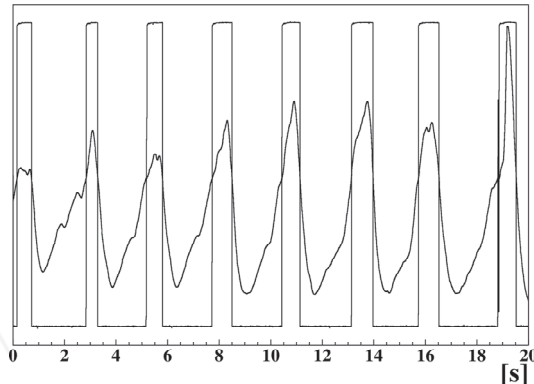

Fig. 10. Sampled signals: the wavy signal is from the sensor while pulses are from peak detector.

2.3.5 Oximetry monitoring

Pulse oximetry provides continuous measurements of blood oxygen saturation, and is from 40 years ago an important medical technique both for emergency and critical care use and for everyday medical checkups (Aoyagi et al, 1974). The theory upon which pulse oximetry operates involves measuring the amount of emitted waves that are transmitted through or absorbed by tissue containing blood. The absorption spectrum of oxygen-rich blood differs

from that of oxygen-lacking blood, and oxygen saturation can be measured based on this difference in absorption.

Then, we remember that the coloured substance in blood, haemoglobin, was also its carrier of oxygen. (Haemoglobin is a protein which is bound to the red blood cells.) At the same time, it was noticed that the absorption of visible light by a haemoglobin solution varied with oxygenation. This is because the two common forms of the molecule, oxidized haemoglobin (HbO₂) and reduced haemoglobin (Hb), have significantly different optical spectra in the wavelength range from 500nm to 1000nm

The oxygen chemically combined with hemoglobin inside the red blood cells makes up nearly all of the oxygen present in the blood (there is also a very small amount which is dissolved in the plasma). Oxygen saturation, which is often referred to as SaO₂ or SpO₂, is defined as the ratio of oxyhemoglobin (HbO₂) to the total concentration of hemoglobin present in the blood (i.e. oxyhemoglobin + reduced hemoglobin):

Arterial SaO₂ is a parameter measured with oximetry and is normally expressed as a percentage. Under normal physiological conditions arterial blood is 97% saturated, whilst venous blood is 75% saturated.

It is possible to use the difference in absorption spectra of HbO₂ and Hb for the measurement of arterial oxygen saturation in vivo because the wavelength range between 600 nm and 1000 nm is also the range for which there is least attenuation of light by body tissues. By measuring the light transmitted through the fingertip (or the earlobe) at two different wavelengths, one in the red and the other in the near infra-red frequencies of the spectrum, the oxygen saturation of the arterial blood in the finger (or ear) is measured.

The medical device useful to this aim is the pulse oximeter. Then, a pulse oximeter is integrated in the remote health monitoring system.

The pulse oximeter is interfaced to the human body by a sensor consisting of two LEDs, one emitting red (660 nm) and one that emits infrared (940 nm) light, that flash alternately, controlled by a dedicated circuit and polarization piloting. The light emitted through the tissues undergoing different attenuation for each wavelength. The resulting light intensity or the light radiation that was absorbed by the tissues is received by a photodetector (photodiode or phototransistor) which varies its resistance according to the amount of light incident from a few ohms to hundreds of MΩ.

The signal is then obtained in current and subsequently is converted into a voltage signal, so a transimpedance amplifier needs. The output signal is sampled by two sample and hold (S / H) amplifier (one for each channel) and sent to two parallel and identical sets of filters: bandpass filter for the extraction of a pulsatile component and a low-pass one having a very low cut off frequency (about 0.2 Hz) to extract the DC component for each signal R and IR. The signal such conditioned is managed by the microcontroller of the PU.

2.3.6 Arterial pressure monitoring

Blood pressure systemic (erroneously known only as blood pressure) is the pressure difference per unit area that exists between an artery and the surrounding environment.

We distinguish between systolic blood pressure (or max) and diastolic (or min). The most used method for measuring blood pressure is the auscultatory one which is based on the use of a sphygmomanometer having a cuff, which inflates and deflates, equipped with a pressure sensor well positioned on the arm in correspondence of the brachial artery and a stethoscope to listen to the sounds of Korotkoff heard during the cuff slow deflation.

This method, although fairly accurate if the dimensions of the cuff are large enough, has some limitations due to the presence of various source of noise and due to acoustic performance of the operator: is the sound of Korotkoff included in a range of frequencies (<200 Hz) where the hearing Human beings are not very sensitive. Moreover, in patients with hypotension, the moment to read the diastolic pressure may be difficult to interpret, as a reduction of blood flow also causes a degradation of Korotkoff sounds.

In place of the auscultatory method, there are other important indirect methods such as the oscillometric method.

This method really provides the mean value of the arterial pressure, but by a numerical algorithm can also provide the systolic and diastolic values. It is based on the measure of the fluctuation of the pressure inside the cuff. In fact, when the blood passes through the artery occlusion caused by inflation of the sphygmomanometer the pressure inside the cuff undergoes small changes. These oscillations are due to the fact that the flow of blood in these conditions appears to be turbulent, so the pressure that the turbulent blood exerts on the walls of the cuff is not constant.

The maximum value of the oscillations occurs at the value average pressure (MAP, mean arterial pressure). Therefore, to assess the values of systolic and diastolic pressure, you should resort to an algorithm mathematician. This algorithm does is to assess the maximum oscillation and calculate the two fractions of correspondence relating to fluctuations in systolic and diastolic pressures. In particular, typical values well correlated with the auscultatory method, are 50% and 80%, respectively for systolic and diastolic pressure. This will involve read the pressure values at these amplitudes of oscillations.

The system designed for arterial pressure monitoring, linked to the portable unit, is based on the oscillometric method and consists of the following main blocks: pressure transducer; band-pass filter for the extrapolation of the oscillations; analog to digital converter (ADC) for signal acquisition output to the transducer and its filtered version; microcontroller for the signal processing; after deflation of the cuff, the microcontroller determines the peak of the pulsatile component and determine the diastolic and systolic pressure as a percentage of that maximum. Figure 11 shows the signals after the filter (oscillating curve) and the output of the sensor (solid curve)

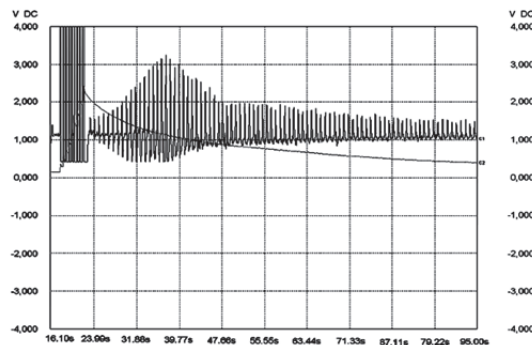

Fig. 11. Arterial pressure monitoring: sensor output (solid curve) and filter output (oscillating curve)

Alternatively the oscillometric method can be implemented the tonometric method that lets you record continuously and non-invasive pulse pressure by compressing superficial artery,

usually the radial artery, the underlying bony structures. The registration of the measured pressure values is done through the use of a piezoelectric transducer applied externally over the artery pulse. The main advantages are: absence of a sphygmomanometer; provides a continuous measurement during the entire cardiac cycle; speed and accuracy.

2.3.7 Body temperature

The body temperature monitoring is performed using an NTC (negative temperature coefficient) sensor with the corresponding signal conditioning circuit based on the Wheatstone bridge method, connected to the microcontroller of the portable unit.

The measure of temperature occurs every hour or other time interval to be programmed or on demand.

2.3.8 Environmental parameters

The values of the environmental pressure, temperature and moisture are essentially correlated to the health status of a person. In fact, it is well known that under certain environmental conditions, especially with high temperature and moisture, a person, especially the children and elderly, may have an illness.

For this reason among the parameters monitored by the described system there are also the environmental ones.

To this aim commercial sensors are used, mounted on the portable unit board. These sensors are interfaced with the PU by buffered amplifiers.

Firmware diagnostics correlate environmental parameters with those of health and correctly interpret the situations of real danger if it occurs.

3. The internet tele-stethoscope: The last generation of the electronic stethoscopes

This device aims at solving the problem of objectification in cardio-pulmonary auscultation, currently not objectifiable, and the ability to perform real-time tele-auscultation in order to improve the diagnostic potential of telemedicine, at present mainly limited to the tele-electrocardiography, the tele-consultation and the sending of delayed reports.

In fact, auscultation of lung sounds and heart sounds is one of the classic diagnostic methods commonly used in medical practice, and runs through stethoscope. Although useful, not-invasive and of rapid implementation, it is a diagnostic test particularly sensitive to the physician's subjectivity, both in the reception quality of biological sounds and in their interpretation for the purpose of diagnosis.

From several years by now amplified electronic stethoscopes with noise filtering systems have been developed to improve diagnostic accuracy.

As far as these solutions have allowed a better perception of biological sounds by the physician and even the recording and the archiving of sounds acquired, however there remains the problem of subjectivity by which the interpretation of sounds is conditioned, and the need for the doctor to be close to the patient, since it is currently impossible the real-time remote transmission of sounds, but only deferred, or upon registration.

The device, which represents a technological evolution in comparison to electronic stethoscopes, allows you to transmit sounds at any distance via internet in real time without suffering any distortion or alteration and allows to correlate, in real-time, spectrum of heart

and lung sounds with diseases, thereby allowing an objective diagnosis. In fact there is a deterministic relationship between the spectrum of biological sounds and pathologies.

The device can also store the recorded sounds useful for comparisons over time to monitor the evolution of diseases.

The device was successfully validated for both heart sounds and lung sounds and showed a considerable educational value for physicians in training who need to gain experience in correlating correctly and objectively biological sounds to diseases. In the following subsections after just a reminder about the origin of biological sounds in Human beings, necessary to understand the method implemented for objectification, the device is described.

3.1 Origin and spectral properties of respiratory sounds

Organic sounds originate from mechanical vibrations in compressible media and are transmitted through tissues as sound waves. The lung sounds, in particular, are generated in large airways, where high speed and air turbulences induce vibrations along the walls of the breathing tubes. Such vibrations are then transmitted through the tissue of the lungs and the chest walls, up to the surface, where they can easily be perceived with the aid of a stethoscope. The generation of lung sounds is directly related to the speed of airflow and to the architecture of the airways. The velocity of air flow is mainly determined by pulmonary ventilation and cross-section of the airways at every level of the lungs.

Terminal airways or alveoli illnesses are responsible for changes in the lung sounds heard on the surface, because the diseased tissues are responsible for the increase or decrease of the sound transmitted. Differences in intensity and characteristics of perceived sounds are, therefore, of great help in identifying specific diseases of the chest, as changes in tissue density involve acoustic attenuation, reflection and refraction of sound waves. Furthermore, the properties of the sound heard on the surface are determined by factors that affect the sound generation and characteristics of the intermediate tissues: every type of tissue is able to attenuate the sound vibrations of different frequencies and in different quantities, which translates in an alteration of the sound spectrum and a lower amplitude sound in certain frequencies (Jingping et al., 1997). When the acoustic properties of tissues through which the sound propagates differ greatly, as between the air-filled lungs and muscles of the chest wall, much of the sound wave is reflected and sound intensity decreases. Then, the large-spectrum sound, generated in the large airways, it is first filtered by the lung parenchyma (the organic material that constitutes the lungs) and chest wall, then reaches into the skin without the high-frequency spectral components: ultimately the lung-thorax system behaves as low-pass filter for respiratory sounds.

When, due to disease, the spongy and full of air tissue of the lungs is replaced by clusters and liquid and becomes a solid mass, the lung-thorax system is capable of transmitting high tones. Therefore, the presence of high frequency components in lung sounds is a symptom of respiratory diseases. The frequency range of the lung sounds in healthy people extends up to 1000 Hz, although the greatest concentration of power is observed between 60 Hz and 600 Hz. With increasing age there is a small increase in power in the band between 330 Hz and 600 Hz. Spectral differences exist between women and men in general, women have tones of breath sounds higher than men.

The best frequency band to obtain the average power is the band between 100 Hz and 600 Hz, because here we have a probability of error less than the band between 100 Hz and 800 Hz, and the information that is lost is negligible because the power is almost entirely concentrated in the first band.

In addition to the chest, another common position to auscultate breath sounds with a stethoscope is on the neck in the hollow above the breastbone to the extrathoracic trachea. The sounds recorded here are called tracheal sounds. These sounds have an amplitude large enough, on average, greater than about 20 dB at low frequencies, and have a frequency range wider than the sounds listened from the chest.

The intensity of breath sounds is greater during expiration than during inspiration. Their spectral power density does not show a peak at low frequency, rather it extends nearly flat in amplitude between 100 Hz and 700 Hz, where the first peak appears, then decreases down to the second peak at about 1500 Hz.

However, the spectral characteristic of tracheal sounds varies considerably among patients, and also depends on the width of the trachea and physiology and physique of the patient. It has been shown that patients with tracheal stenosis have a spectrum with a significant increase both in power, with a peak at about 1 KHz, and in bandwidth, with spectral power that extends from 600 Hz to 1300 Hz.

3.2 Origin and spectral properties of heart sounds

Heart sounds are produced by the movement of the valves and the turbulent flow of blood. The normal heart sounds consist of two parts: a first pulse due to the closure of the atrio-ventricular valves, which denotes the complete passage of blood in the ventricle, a second pulse due to the closing of the valves between ventricles and great vessels, which denotes the complete passage of blood from the ventricles to the aorta and pulmonary arteries.

The blood is pushed through the arteries by the mechanical movement of the heart, but if the arteries are partially occluded blood flow is disturbed, and this creates turbulence in the arterial. Following this pressure variations are produced and heart sounds called murmurs due to blockage of his arteries, can be heard on the surface of the chest, matching the outbreaks of auscultation. The murmurs are high frequency sounds that cover a range between 250 Hz and 1000 Hz. They become appreciable when the occluded area of the arteries reaches 75% of the total. Several studies confirm that the frequency range between 400 and 800 Hz is associated with coronary artery stenosis.

The spectrum of non-pathological heart frequencies extends between 10 and 400 Hz, but the range that provides more info is between 20 and 150 Hz. The lung sounds and the muscle noise contained within the bandwidth of 100 Hz interfere with the heart sounds and this makes difficult the distinction necessary for diagnosis. With the use of electronic devices and appropriate numerical algorithms (Yang-Sheng et al, 1998) it is possible to distinguish the heart sounds and lung sounds by filtering out noise.

3.3 Description of the internet tele-stethoscope

The device permits the acquisition of lung sounds and heart sounds, the real time spectral analysis and transmission via internet to a remote PC, both for sounds and for its spectrum. The device is PC-based being connected to a PC to function, and has a hardware component consisting of a sensor and a filter-amplifier and a software driver.

The hardware side, respiratory and cardiac sounds are picked up by the microphone capsule, housed in a bell stethoscope to be affixed to the patient's chest. The transduced signal is amplified and filtered. The user can select the type of filtering to be applied to the signal, so as to enhance the cardiac and respiratory components. The conditioned signal is then sampled and quantized by a form of A/D conversion.

The system is powered by a rechargeable battery in the device itself using a special charger.

It has not been allowed the use of any compression algorithm, so as to preserve the quality of the transmitted signal.

The connection to a PC is possible as with a cable to the sound card of the PC as via Bluetooth. A microcontroller is necessary to oversee the management of the device functioning.

The prototype of the internet tele-stethoscope has the same chassis of the typical well known electronic stethoscope but it can also be redesigned assuming the appearance similar to that of a normal PC mouse, as shown in figure 12.



Fig. 12. Possible new mechanical design of the internet tele-stethoscope, alternatively to the classical chassis

The software allows the acquisition of sound through a PC and real-time transmission of audio streams, via web, to another PC; the software implements, moreover, all the digital filtering necessary to optimize the auscultation including the osculation, the Fourier transform to perform spectral analysis, environmental and muscle noise filtering, heart sounds from lung sounds filtering (Paris et al, 2000). The interface, shown in figure 13, allows archiving of sounds, playback, deferred analysis, spectrum printing, zoom, sending audio files.

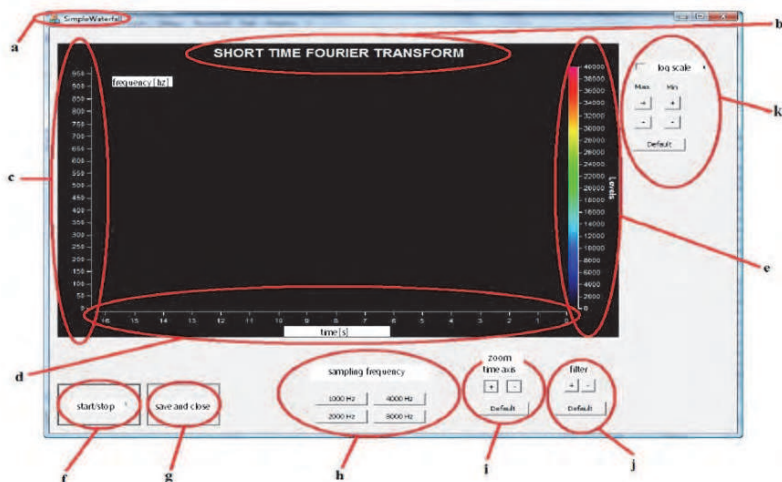

Fig. 13. Software User Interface: (a) Program name. (b) Title. (c) Frequency axis. (d) Time axis. (e) Intensity scale. (f) Start button: to start the program, pause it and restart it. (g) Quit button. (h) Sampling rate selection buttons: 1 - 2 - 4 to 8 kHz. (i) Zoom of the times. (j) Filter: allows you to increase or decrease the application of the video filter; if the limit is decreased, the filter is not applied. (k) Management of the intensity scale: allows you to switch between linear and logarithmic scale, and vice versa, and to vary the range of the scale. Move your mouse over the image appear zoom options, files, etc...

3.4. Validation

Several acquisitions of lung sounds and heart sounds have been made and compared, both with the new device and with a reference electronic stethoscope of the best commercially available. The comparable results indicate the reliability of the new diagnostic device. A few pictures are shown as examples of the sound spectrum. Figure 14 shows the sound spectrum of a tracheal sound acquired and recorded by the reference stethoscope (a) and by the new device (b).

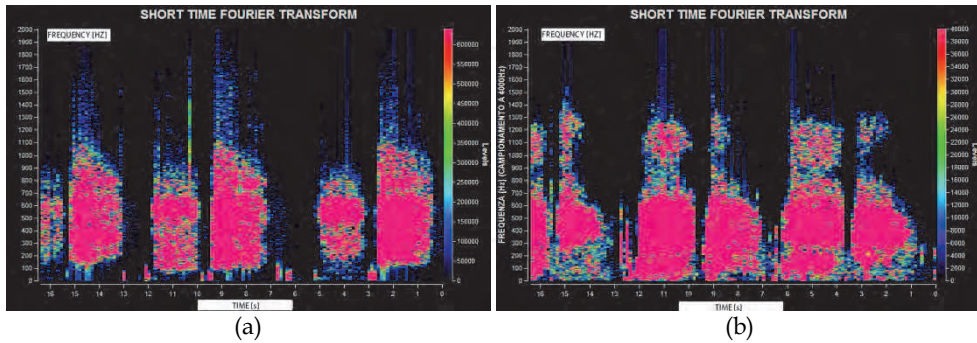

Fig. 14. Spectrum of a tracheal sound acquired by the reference electronic stethoscope (a) and by the new device (b)

Figure 15 shows the sound spectrum of a heart sound concerning the aortic acquired using the reference electronic stethoscope (a) and by the new device (b), respectively.

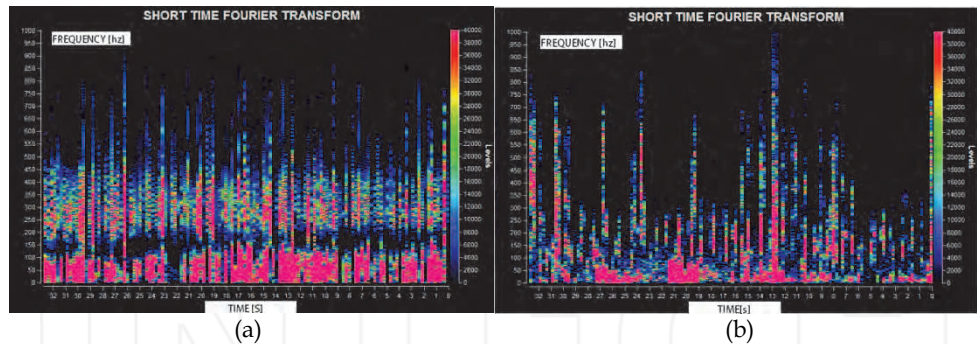

Fig. 15. Spectrum of the heart sound in aortic area by electronic stethoscope (a) and by the new device (b)

Figure 16 shows the sound spectrum of a heart sound concerning the tricuspid outbreak acquired and recorded by the reference electronic stethoscope (a) and by the new device (b). In all cases, the diagnosis obtained via the new device and by reference stethoscope is the same.

Remote transmission test were also performed to assess the feasibility and accuracy of Web-based Heart and Lung sounds Auscultation (W) HLA in comparison to Traditional (T) HLA. For this purpose have been studied 21 patients in a routine setting of the Cardiomyopathy Unit of Policlinico di Bari. Each patient was assessed by two expert cardiologists (Obs1-2) in

two consecutive steps (W-HLA and T-HLA) using a cross-over study design. W-HLA was performed by using the internet tele-stethoscope. The high-quality audio signal was transmitted over the Internet by standard ADSL connection from the internet tele-stethoscope to a remote personal computer where the observer was able to hear and record HLA audio for W-HLA

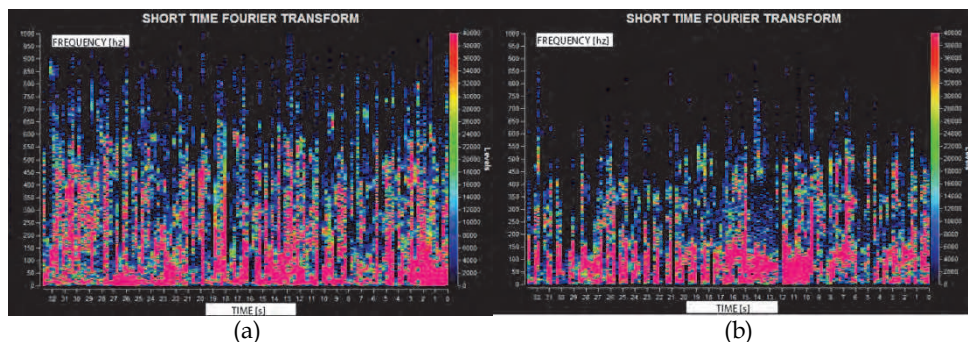

Fig. 16. Spectrum of the heart sound in tricuspid area by the electronic stethoscope (a) and by the new device (b)

A trained nurse positioned the stethoscope on topographical areas under webcam-assisted audiovisual guidance. T-HLA was performed by traditional binaural stethoscopes. Auscultatory findings were assessed by pre-classified values. Data were analyzed for concordance and tested by Fisher’s exact test ($p < 0.05$) and kappa-test.

The results are summarized in table 2 in terms of intraobserver concordance of W- vs T-HLA (No. of concordant findings, (%)) for Obs1 and Obs2 for the overall findings, for heart sounds, and for pulmonary findings; and in terms of interobserver concordance of Obs1 vs Obs2 for the same findings.

FINDINGS	INTRA		INTER	
	WEB versus ACOUSTIC		OBS 1 versus OBS 2	
	OBS 1	OBS 2	WEB	ACOUSTIC
Overall	217/231 (93.9%)	214/231 (92.7%)	224/231 (96.8%)	219/231 (94.8%)
Heart sounds	81/84 (95.2%)	79/84 (94.1%)	79/84 (94.0%)	83/84 (98.8%)
Pulmonary	60/63 (95.2%)	59/63 (93.6%)	59/63 (93.6%)	62/63 (98.4%)
Systolic heart murmur chronology	19/21 (90.5%) $\kappa=0.82$	18/21 (85.7%)	17/21 (80.1%)	19/21 (90.5%) $\kappa=0.82$
Pulmonary rales	20/21 (95.2%) $\kappa=0.64$	19/21 (90.4%)	20/21 (95.2%)	21/21 (100%) $\kappa=0.47$

Table 2. Validation statistics for the internet tele-stethoscope

Therefore, heart and lung auscultation, as assessed by concordance analysis in our patient series, yielded high concordance of auscultatory findings for the traditional and web approach. Intra- and interobserver concordance were not different for the two observers in

the two settings. Thus, web heart and lung auscultation is a promising method for telemonitoring of patients affected by heart failure and the designed internet telestethoscope is reliable.

4. A pain button for real-time rescue of patients having heart failure and high risk of life

The purpose of the pain button device described in this section is the provision of extended monitoring for patients under therapy after infarction, data collection in some particular cases, remote consultation, and low-cost ECG monitoring for the elderlies that are unable to announce their failure condition. So the system allows real-time rescue of patients having heart failure and high risk of life. The pain button is based on the SMTP (Simple Mail Transport Protocol) and SMS (Short Message Service). The device will be described in to two different configurations:

- i. Pain Button (PB), that features GSM/GPRS technology for data transmission. It is suitable for outdoor use.
- ii. Wireless Pain Button (WiPB), that features Wi-Fi 802.11g technology (over and above GSM/GPRS) for data transmission. It is suitable for indoor and outdoor use.

Communication between PB (or WiPB) and a remote PC (or portable phone) server is achieved through programming the device by an user-friendly web server interface. Through the use of Wi-Fi connection is possible to configure the device while the patient wear it remaining free to move (without using wired connections).

Access to web interface to configuring the device is granted only to users that have right permissions by a login/password access form.

The device can send automatic and manual alarm status reports. In case of illness the patient presses the Pain Button. Otherwise, PB acquires and processes ECG signal and reports automatically abnormal cardiac behaviour (automatic status report). The system performs analog-to-digital conversion and analyzes in real-time any variation in shape, duration, amplitude and frequency of ECG. So it is able to examine and identify a disease from its symptoms identifying: tachycardia, bradycardia, arrhythmia, sinoatrial node block and ventricular extra systole, ischemia and infarct.

Digital data are stored into internal flash memory or in external memory card MMC/SD. The system embodies a GPS (Global Positioning System) receiver to acquire the real-time patient position.

To ensure the resilience of system, PB uses three different transmission technology: GSM to send SMS (Short Message Service), GPRS and Wi-Fi 802.11g to send verbose alarm report (ECG signal and GPS coordinate) to PC. The remote observer can monitor the patient ECG and his position, simply by typing the connection parameter.

4.1 Concept and design

As we have stated, the device purpose is the provision of extended monitoring for patients under therapy after health disease (especially after infarction), health status data collection, remote consultation and low-cost ECG monitoring for the elderlies that are unable to announce their failure condition. So the system allows also real-time rescue.

The device has been designed and prototyped into two configurations.

The former configuration, named Pain Button (PB), features GSM/GPRS wireless technology for data transmission. It is suitable for outdoor use. The block diagram is shown in figure 17.

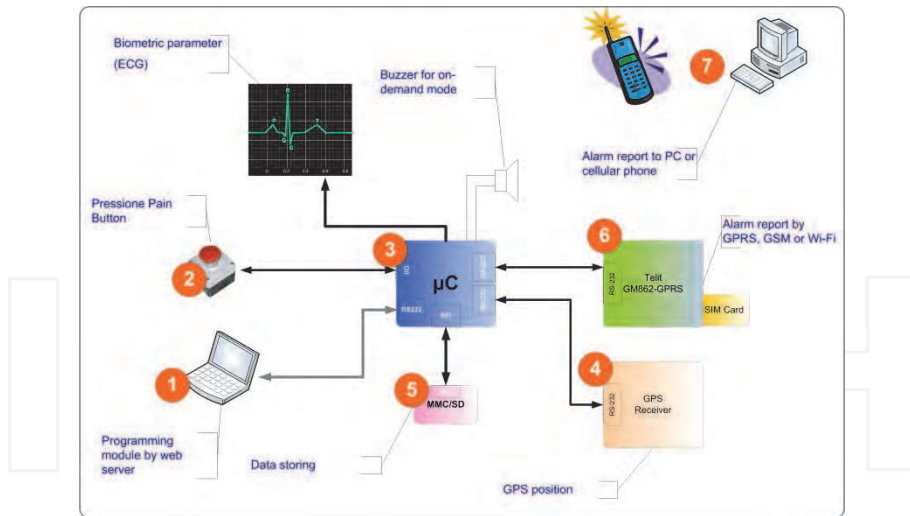

Fig. 17. Pain Button (PB) block diagram

The latter configuration, named Wireless Pain Button (WiPB), features Wi-Fi 802.11g wireless technology (over and above GSM/GPRS) for data transmission. It is suitable for indoor and outdoor use. Its block diagram is shown in figure 18.

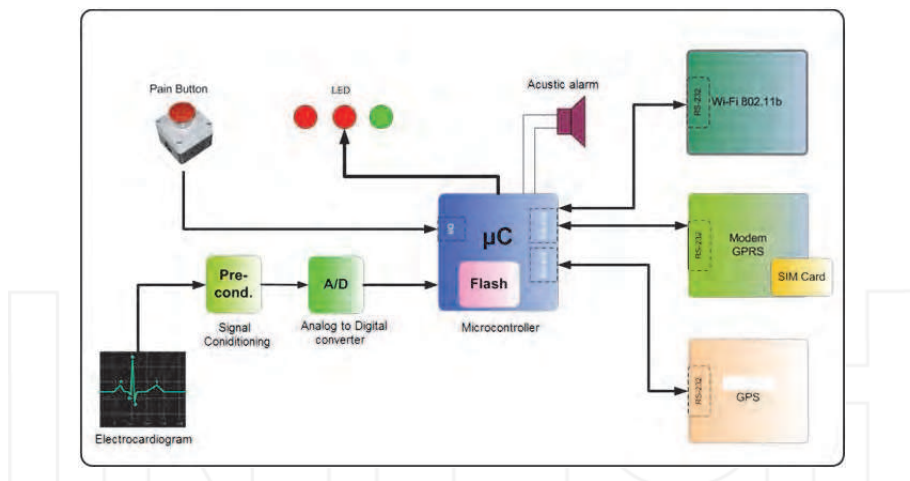

Fig. 18. Wireless Pain Button (WiPB) block diagram

Both configurations are equipped with a GPS receiver to signalling the exact patient position. It is a basic requirement for a telemedicine system, since it is necessary to allow an immediate assistance in case of disease.

Both configurations are equipped with an analog-to-digital front-end to convert data and transmit them to the central unit. An external sensor port is provided in patient home communication interface device.

The ECG device is integrated in PB and WiPB. It is because ECG parameter is the main factor to determine the patient condition and possible risk of life.

In the following paragraph the method implemented in PB/WiPB to automatically determine heart disease will be described.

4.2 ECG automatic interpretation and the algorithm for heart disease detection

As already reminded in section 2. electrocardiography is a transthoracic interpretation of the electrical activity of the heart over time captured and externally recorded by skin electrodes by an electrocardiographic device.

A typical ECG tracing of a normal heartbeat (or cardiac cycle) consists of a P wave, a QRS complex and a T wave. A small U wave is normally visible in 50 to 75% of ECGs. The baseline voltage of the electrocardiogram is known as the isoelectric line. Typically the isoelectric line is measured as the portion of the tracing following the T wave and preceding the next P wave. Figure 19 shows the model a typical ECG waveform (which real shape is shown in figure 5) .

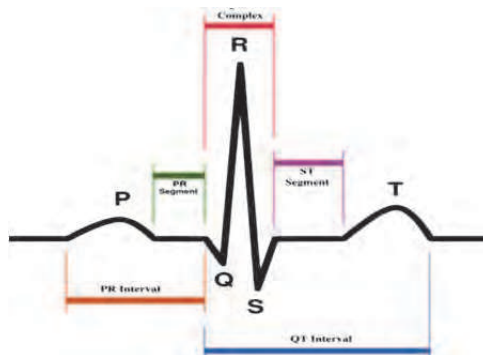

Fig. 19. Electrocardiogram waveform model

The shape, length and amplitude of ECG allows to determine the heart condition and possible heart disease. To reveal all ECG parameters, the system uses a QRS detection algorithms based on threshold method. Since the QRS is the wave complex with higher amplitude, it is a simpler method to calculate the heart beat. The problem associated with this method is right threshold choice.

To this aim, according to (Evans, 1998), the equation (3) has been used:

$$U_{TH} = \frac{A}{2} + \frac{N}{A} \cdot \ln\left(\frac{P_0}{P_1}\right) \quad (3)$$

where P_1 and P_0 are respectively the probability to have and not to have a QRS complex, A is the ECG signal amplitude and N is noise variance. So, assuming typical value for this parameter (according to AAMI - Association for the Advancement of Medical Instrumentation), it results a threshold of 70%. This value was the starting point for microprocessor data processing to calculate the heart beat (HB). In fact, when HB is found it is simple to identify various heart disease like tachycardia ($HB > HB_{tach}[\text{bpm}]$) or bradycardia ($HB < HB_{brady}[\text{bpm}]$).

The parameter HB_{tach} and HB_{brady} could change from patient to patient. So the system implements a simply web interface to change these reference parameter.

Moreover, the algorithm implemented in the device (as PB as WiPB) allows to automatically identify arrhythmia, beyond tachicardia and bradycardia. In this case, we defined an arrhythmia factor α as in equation (4):

$$\alpha = \frac{\Delta T_1}{\Delta T_2} \quad (4)$$

where ΔT_1 and ΔT_2 are respectively the time between three consecutive QRS complex, like Figure 20 shows. In an ideal case, we will have an arrhythmic complex when $\alpha \neq 1$, while in the real case, we define the following range by equation (5):

$$\Delta T_1 < (\Delta T_1 + \Delta T_2) \cdot 40\% \quad (5)$$

that is,

$$(\alpha < 0.25) \text{ and } (\alpha > 4) \quad (6)$$

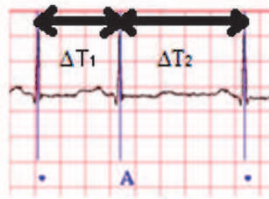

Fig. 20. arrhythmia factor α and detection method

4.3 Operation example: Wireless alarm and data transmission

The device can send automatic and manual alarm status reports. In case of illness the patient presses Pain Button to signalling his condition (manual status report). Otherwise, PB/WiPB acquires and processes ECG signal and reports automatically abnormal cardiac behaviour (automatic status report). The system performs analog-to-digital conversion and analyzes any variation in shape, duration, amplitude and frequency of ECG in real-time accordingly to the previous described algorithm.

Digital data are stored into internal flash memory or in an external memory card MMC/SD, based on overall data.

In order to ensure the resilience of the system, PB/WiPB uses three different transmission technology: GSM to send SMS, GPRS and Wi-Fi 802.11g to send verbose alarm report (ECG signal and GPS coordinate) to PC. Figure 21 shows all possible transmission method implemented in PB/WiPB.

Thanks to Wi-Fi 802.11g interface, it is possible to configure the system without using any cable and while the patient wears it, even directly by clinic. Moreover, the system integrates a web server to make simpler the configuration step. Simply connecting trough a web browser (like Internet Explore, Firefox or Safari) and inserting the IP address of device, is possible to enter the ECG parameter, phone number to send the alarm report or email address of PB-Client, like shown in Figure 22.

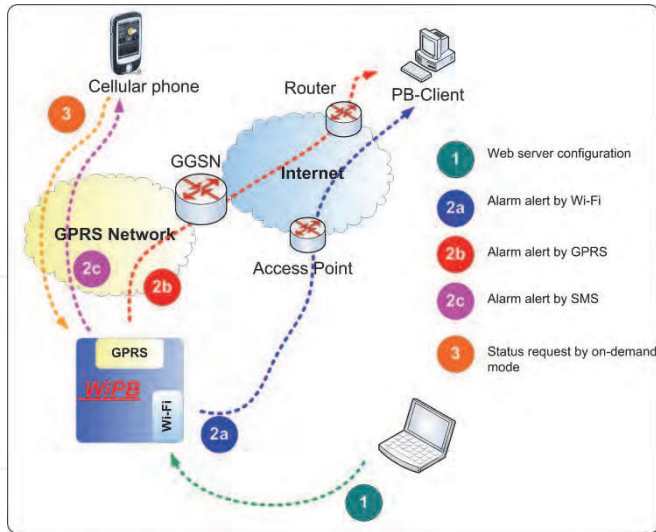

Fig. 21. Data transmission from PB to PC and cellular phone

The screenshot shows the web interface for programming the WiPB. It is titled "Wireless Pain Button" and has a logo. The interface is divided into two main sections: "SMS CONFIGURATION" and "EMAIL CONFIGURATION".

SMS CONFIGURATION:

- SMS Enable:** Radio buttons for "Enable" (selected) and "Disable".
- Recipient Cellular Phone:** Text input field containing "3401234567".
- Submit:** A button to save the SMS configuration.

EMAIL CONFIGURATION:

- EMAIL Enable:** Radio buttons for "Enable" (selected) and "Disable".
- Recipient Email:** Text input field containing "email@poliba.it".
- Submit:** A button to save the email configuration.

Below the email configuration, there are additional fields for SMTP settings:

- Server SMTP:** Text input field.
- SMTP Port:** Text input field.
- Sender Email:** Text input field.
- Username:** Text input field.
- Password:** Password input field (masked with dots).
- Email Authentication:** A checkbox labeled "checked" which is checked.
- Debug:** Text input field.
- Submit:** A button to save the SMTP settings.

Fig. 22. Web Interface to programming WiPB by Wi-Fi

To allow the security access to the system, all web pages access has been protected with username and password.

In this project data transmission by GPRS or Wi-Fi 802.11g uses application layer protocol (SMTP) based on reliable TCP protocol as it offers permanent connection channels and data integrity.

4.4 Management software

To be useful, a telemedicine system have to be supervised by an integrated client software. The software for PB/WiPB (named PB-Client) was developed using Delphi language. It is capable to supervising more than one PB/WiPB, showing for each PB/WiPB alarm status and type, ECG trace and geographical position.

4.5 GPS

A reliable telemedicine system have to automatically notify an illness. Beyond this main requirement, it is necessary, for example in case of heart failure or high risk of life, to know exactly where the patient is. In this way it's possible to reduce the rescue time. So the PB/WiPB device embodies a GPS receiver to acquire the real-time patient position. It has been also developed the client-side software with a Graphical User Interface (GUI), able to capture alarm status report, showing exact patient position by interaction with software for geographical visualization and analysis, like Microsoft Mappoint and Google Maps (however it is possible to integrate with other software for geographical visualization). So the remote observer can monitor the patient ECG and his position, simply by typing the connection parameter.

4.6 Features and future of the pain button

A working prototype of PB/WiPB has been realized. The dimensions are 9.5x5.5 cm², so it is easily wearable.

PB and WiPB consists of a set of WiFi/GPRS-enabled instruments that communicate wirelessly over Internet. Equipped with a miniature circuit board, devices such as a ECG monitor or other external sensors can communicate with clinic until they are within range of an access point (only in WiPB configuration); if no access points are found, the device uses a GPRS connection to access to Internet; even if no GPRS signal is detected, the device uses the GSM network. It sends the encrypted data to the clinic, which consists of multiple redundant servers and makes the data available to authorized specialist via web server. The same advanced communication technologies allow the transmission of data dealing with implantable devices such as defibrillators and pacemaker.

The PB/WiPB is easy to operate, so patients with limited abilities or patient with heart disease can use it without difficulty: they only have to press the pain button if needed, but even if they can't press this button, the device automatically sends data.

Due to its features the PB should be a very nice solution in the future to improve the quality of life and the life expectancy of diseased, high risk subjects.

5. RFID technology application improving the health-care quality and efficiency

The effect of information and automation technology is manifesting more and more widely in medical procedures, bringing substantial benefits to the health and welfare of all patients.

We can think about already existing applications as the ability to book a medical examination via internet, or use sophisticated diagnostic techniques (CT, MRI, PET), or the possibility to perform minimally invasive endoscopic techniques, or telemedicine.

Among these, data processing certainly is a crucial aspect for patient care. Health management and control, indeed, are based on using, transmitting and comparing a large amount of data, information and heterogeneous knowledge. However, in recent years the need to exchange data has increased dramatically, both within a health facility (among different subjects and specialized units.), and among geographically distant facilities. Amongst other things, with the rising organization cost and complexity, we can't think to disregard an adequate information system consisting of management software and complex databases which ensure organization control and optimization (Mori et al, 2001).

Although computerization drastically increases the efficiency and effectiveness of data processing procedures, has less impact in terms of increasing the care quality or the patients' quality of life, especially for elderly, chronically ill, accident-prone patients. Nevertheless, these benefits not always improve patient's health directly. For example, in the case of an emergency relief to an injured or sick person, it is essential to obtain timely patient's past medical history, in order to prevent the supply of incorrect treatments which could further aggravate the situation.

Then, the computerization of health services through the use of complex software and data base, allows a more efficient organization of service and care but doesn't usually have a significant impact in terms of improving the care or patients' life quality, especially for elderly, chronically ill, accident-prone patients and in need of urgent assistance. In order to address this shortage, it is useful a system invented by the author based on RFID (Radio Frequency Identification) technology, consisting of both hardware and software part, described in this section.

It wants to demonstrate how to dramatically improve medical history acquisition procedures and face the most serious situations, using RFID technology; not forgetting, among others, further important advantages as integration into an existing computer system, or the economic factor.

5.1 A quick reminder about RFID Technology

RFID is a wireless technology that represents an innovative solution in the field of processes automation. Although its origin is not recent, it will provoke a veritable revolution in every productive sector in the coming years. The reason why only in recent years RFID has spread, is because its use has changed over times and, if until recently, RFID could be considered as a still evolving technology, currently is moving towards a stage of expression maturity.

The very acronym definition is very clear in specifying and limiting the technology involved:

- Is a technology that allows the identification (i.e. the unique recognition) of an object or living being.
- Is a technology that uses radio frequency.

At the basis of its operation there is an intuitive idea of being able to identify, through an intelligent label (called "tag", "transponder" or "data-carrier device") without any need for physical connection, any object such as products, animal or people. These transponders, unlike their predecessors bar codes, have the ability to store on a chip an information that

can be transmitted via radio waves to the appropriate reading devices (readers or interrogators). Then data is sent to a central computer to be interpreted and processed.

To understand the significance of this mechanism is enough to think that on a single chip you can put several pieces of information (from the serial identification code, name, last name, etc.) and that the readers, depending on applications, are able to capture tags information at a distance ranging from a few centimeters to several meters.

The best RFID transponder package matching the described project criteria is compliant to the ISO 7816 standard, where we find credit cards, personal identification cards and especially smart cards. In fact, these are often used when transactions must be processed quickly or hands-free, such as on mass transit systems, where a smart card can be used without even removing it from a wallet.

RFID technology has a very large presence in the smart cards field.

There are standards like ISO/IEC 14443 or ISO/IEC 15693 that allow for communications at distance ranging from a few centimeters up to a meter at operative frequency of 13,56 Mhz, or also ISO/IEC 11784 ISO/IEC 11785 allow for communication at 134,2 KHz frequency and the just mentioned distance.

Smart cards are advertised as suitable for personal identification tasks, because they are engineered to be tamper resistant.

The embedded chip of several smart card models usually implements some cryptographic algorithm.

Last but not least, the amount of embedded memory varies from a few bits up to a megabyte and allows us to insert all necessary personal and clinical data.

5.2 The advantages of RFID technology applied to the health-care services

The RFID-based system we are describing, allows to improve the health care quality because it allows doctors a very quick consulting of the clinical data of a patient; moreover, the system is perfectly integrated into any local/national or international health information system and data base.

The importance of having promptly the patient's medical history is also crucial to speed up healing process and reduce risk likelihood. Consider, for example, a patient must be urgently admitted to hospital and does not know or cannot report all the critical information needed before surgery, he should be first subjected to a series of investigations and then undergo surgery, or suffer intervention without collecting the above information with high risk of mortality.

Therefore, by equipping any person of an RFID smart card and by equipping any hospital of an RFID wireless smart card reader for patient identification connected to a computer, we have implemented the instantaneous and automatic access to all patient's clinical/medical history information stored in a personal folder of files into database containing one folder for each patient.

The database should be world wide and everywhere located, not necessarily on the hospital computer, if the hospital computer is internet connected.

The designed system meets requirements and benefits ranging from simple procedures streamlining for acquisition of individual's clinical data, to the access to all clinical / history data for patients unable to exhibit them (because they are unconscious, or because don't remember, etc.), to the automatic creation of a database in compliance with health service computerization requirements.

In the following subsections will be discussed the support technologies and the system characteristics in particular.

5.3 RFID-based system technical and operation features

The hardware part of the device consists of RFID smart card (tags) and a receiver (reader). As already stated, their radio frequency interaction allows the unambiguous recognition of people, objects or animals at distance.

In the patient tag are stored the main patient's data (i.e. name, surname, age, address, main pathologies, eventual allergies, etc, depending on the integrated memory available).

The software, however, is composed primarily of a relational data base which is a health facility database with patient's information and clinical details inside, and secondly of a very intuitive graphic interface to manage both the RFID device and the data base. The data base is self-creating, as will be explained later.

Any health facility user is delivered with an RFID tag card, which stores his data (and clinical details). By equipping any person of an RFID smart card, and by equipping any hospital of an RFID wireless smart card reader for patient identification connected to a computer, the system allows the instantaneous and automatic access to all patient's clinical/medical history information stored in a personal folder of files into data base containing one folder for each patient. The data base should be world wide and everywhere located, not necessarily on the hospital computer, if the hospital computer is internet connected.

Assuming the use of the system in the hospital or nursing home reception, if the user comes with wearing the tag within the detection distance (less than a meter), the system automatically recognizes the individual and searches his data within the central data base, which then are also printed on the screen of an operator.

If a detected tag contains invalid reference data in the database, or if the patient is inserted for the first time in the database, it is quite automatically updated by the system by creating, without any human intervention, a new record that contains the data taken directly from the tag and possibly displaying the new acquired information. Then, for the new patient, the system provides the automatic creation of the personal folder as the patient has been identified by the RFID reader, and the automatic transfer of the main data from the personal smart card (self-creating data base).

Therefore, the system allows you to create a dynamic database that updates itself without the aid of any employee and that makes immediately available to health professionals (doctors, paramedics, etc..) all information relating to patient data stored in the its own RFID smart card, such as medical history including current therapies, diseases, examinations reports, specialist reports and all that is deemed useful to include in the data base. The remarkable feature is that the access to the patient's folder occurs suddenly and automatically on a computer connected to the RFID reader, as the patient has been identified. In this way is not needed for any description by the same patient about its own clinical history thus reducing drastically the misunderstanding and the forgetfulness.

To fulfill these tasks, the system was modeled according to the block diagram in figure 23.

From the left, we have the presence of the RFID tag assigned to each patient which interfaces to the reader through the appropriate antenna; the reader, in turn, is connected via serial cable to the port available on the PC and controlled by a dedicated software class. The data flow goes directly into the main form, which provides data management and visualization through the dedicated forms. Finally, the same core module provides the graphical interface for input / output with the healthcare professional.

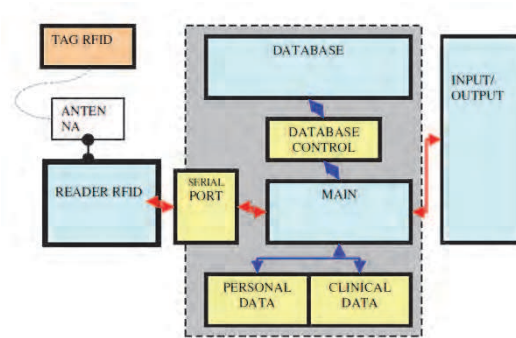

Fig. 23. Block diagram of the hardware part of the designed RFID-based system

The software part of the system, developed in Visual Studio environment, consists primarily of a relational database simulating a health facility database with patients' clinical data inside, and secondly of a very intuitive graphic interface to manage both the RFID device and the data base.

The software interface is designed to provide maximum ease of use and maximum usability of the information by using a rational approach that privileges the automatic rather than total control of the instrument but without sacrificing functionality.

In the main window of the software, shown in figure 24, are condensed all necessary controls to access software features as the data table and controls for managing records and information related to them. These controls reproduce features like search, delete, edit, create new record, regardless of the particular format of the database connected to the system (Access, SQLServer, MySQL). Indeed, designing the database control class through ADO.NET methods and the SQL language, allows a certain independence from the data source, which, in this context, translates into a great ease of integration with existing databases.

In addition there are buttons for connecting and disconnecting the RFID device from database.

Buttons for RFID reader are only two, allowing the connection and disconnection from the device. The procedures for reading the tags, recognizing and displaying information, are autonomously managed by the software, which requires the reader to make cyclical readings every two seconds. The device responds in three main ways:

- Tag not found
- Tag found
- Tag is invalid or not recognized

An answer like "tag not found" occurs in the absence of a transponder within the operative range. A message such as "tag detected", however, starts procedures for the recognition and eventual data drawing, which takes about one second of operation. The third message ("Invalid tag or not recognized") involves the display of warning messages in circumstances of incorrectly coded or partially damaged tags.

Even if reader detects a valid tag that does not match any reference in the database, or if the patient is included for the first time in the database, he is quite automatically updated by the system by creating, without any human intervention, a new record that contains the data taken directly from the tag and possibly displaying the new acquired information. Then, for

the new patient, the designed system provides the automatic creation of the personal folder as the patient has been identified by the RFID reader, and the automatic transfer of the main data from the personal smart card. This important feature allows you to create a dynamic database that updates itself without the aid of any employee. Moreover, the speed of data exchange with the effectiveness of a good RFID system spares the transponder owner to show his card, and linger near the recognition point, in the interest of timely intervention in urgent cases.

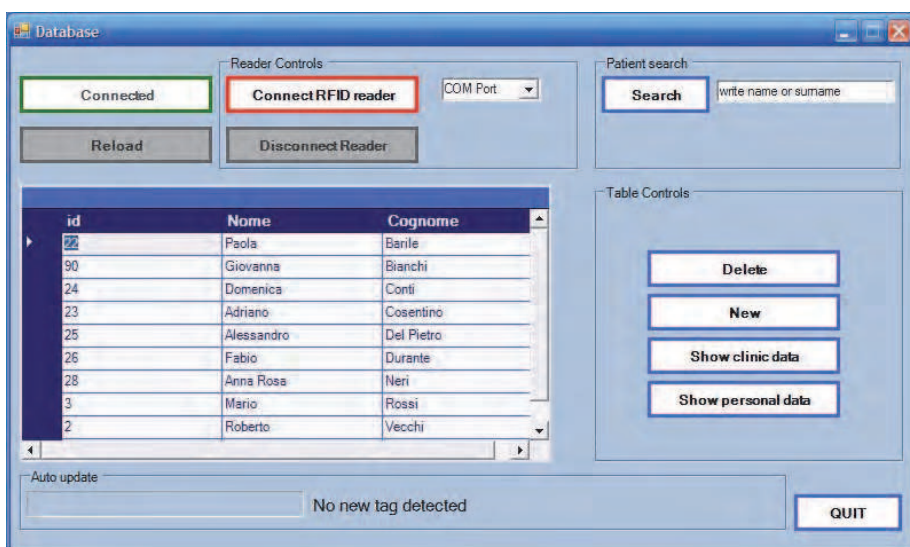

Fig. 24. Main menu of the software part of the RFID-based system

Finally, we should highlight that the system also has the possibility of writing information on transponder, so any new intervention, examination or, a more general clinical and medical history data updating can be always recorded on the patient smart card.

5.4 System usefulness

The use of well designed system actually allows a drastic reduction in recognition time and the immediate availability of patients' generic and clinical data. For example, in the case of manual recognition and data acquisition, the time ranges from a minimum of a few minutes to a maximum of about 40 minutes, while exploiting the automation of our system, we need about one or two seconds. It's obvious that in a urgency situation, the immediate availability of the subject's medical history provides the choice of an effective and especially timely cure. Another remarkable feature is that the access to the patient's folder or the creation of it occurs suddenly and automatically on a computer connected to the RFID reader, as the patient has been identified. In this way is not needed for any description by the same patient about its own clinical history thus reducing drastically the misunderstanding and the forgetfulness.

Furthermore, the particular system architecture with the extreme simplicity and high automation, do not steal time to health personnel to assimilate new procedures, contributing to an effective integration in any existing health facility information systems.

Also the economic sphere should not be underestimated, in fact the cost of RFID devices for such applications is, after all, quite low; just think that now transponders price varies from a few cents to a few dollars depending on the amount of memory or the complexity of the integrated circuit. Thus, a system conceived in this way is capable to combine an information procedures streamlining with a cost containment policy.

Ultimately, the system can operate in a simple and efficient data flow (medical records, personal data) that is immediately available and always updated, providing a definite advantage for both the medical staff and patients.

6. A PC-based system for remote medical visits oriented to home care applications

In this section it is presented a highly innovative system aimed at the home tele-assistance, prototyped and verified by the heart specialists of the U.O. of Cardiology in the general hospital (Polyclinic) of the University of Bari. The system, invented by the author, is patent pending (Giorgio, 2008).

In the context of telemedicine it must be considered as a really innovative product in which all the most advanced technologies of biomedical engineering, information and communication converge to guarantee an efficient and reliable home assistance that allows the patient a highly better quality of life in terms of prophylaxis, treatment and reduction of discomfort connected to periodic out - patient controls and/or hospitalization, and allows considerable savings on the sanitary expenses.

The most recent developments in the field of electronics (technology), informatics and telecommunications let imagine applications in the telemedicine and home care sector which could mark a turning in the quality of the services for sanitary assistance prevention and care.

It above all deals with home care services of chronic patients or patients afflicted by pathologies (such as cardiac decompensation or obstructive chronic bronchopathy), for which the home monitoring, as sketched in figure 25, can often substitute the hospitalization with significant advantages in terms of the patient's quality of life and of sanitary expense saving.

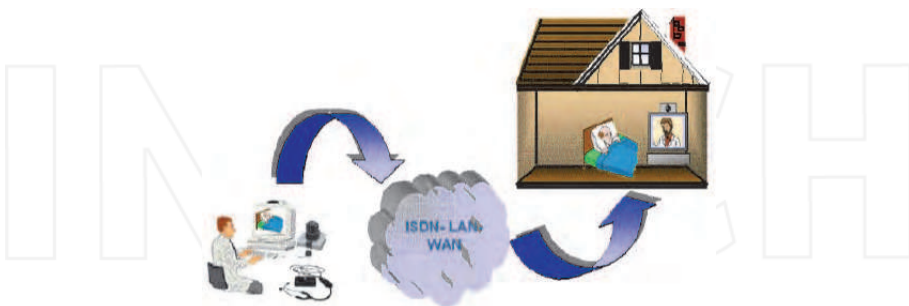

Fig. 25. Typical telemonitoring application for home care

Although there are already available instruments for the remote detection of the electrocardiogram, the cardiac and pulmonary tele-auscultating is not carried out yet.

Moreover, the known tele-electrocardiographs are able to transfer the electrocardiograms only after the acquisition, not in real time and are mostly and strongly orientated towards

the sanitary emergencies. In fact they are typically installed on ambulances and need experienced staff for the utilization.

On the other hand it is essential to observe that, through the electrocardiogram is extremely important, it is not the only source of information useful to evaluate the patient's health.

It is obvious, therefore, that there is a rather limited offer of the current market with regard to the requirements which a health service should meet, if it is in the lead with regard to the effective potentialities offered by the present technology.

Particularly we recognize deficiency or total absence of reliable and valid telemedicine platforms which allow the follow up of patients with cardiac decomposition or of chronic ones or which allow the execution of medical examinations with a doctor in a different place regard to the patient but the doctor must be able to execute a complete and meticulous control of all the main vital parameters presently measurable: electrocardiograms, spirometry, oximetry cardiac tones, pulmonary sounds. The described system aims to compensate for these shortcomings.

6.1. Main features and diagnostic capabilities of the remote medical visits system

As previously stated, the remote medical visits system is a medical electronic and informational platform for diagnostic use, which permits the doctor to carry out a complete cardio-respiratory control on remote patients in real time.

The system consists of two parts: a patient station and a doctor position, both compact and light easily transportable both the positions are composed of committed laptop, hardware and software.

The patient position is equipped with miniaturized PC-based diagnostic instruments and is suitable for pediatric use. It is possible to get also many patient positions for only one doctor position.

The diagnostic instruments are connected to the host PC via USB or via Bluetooth or zig bee. Then, the system is made up of the following basis items:

- a. Server placing (posting) (used by the patient) or rather PC/notebook equipped with:
 - Diagnostic instruments (electrocardiograph, electronic stethoscope, pulse oximeter, etc.)
 - Software tool put in beforehand and used for the transmission of the data in real time and filing of the data acquired also by different patients
 - Kit for the audio/video communication and the remote transmission of the sounds.
- b. Remote client posting (used by the doctor) or PC/notebook equipped with:
 - Software tool put in beforehand and used for the acquisition of the data in real time and for the filing of the data coming also from different patients
 - Kit for the audio/video communication.

Although there are many diagnostic tools, the system is contained in a small suitcase, as shown in figure 26, easy to move and carry. This is because miniaturized and PC-based diagnostic tools, are used.

As if the doctor is present personally near the patient, the system allows him to receive, the data simultaneously at the acquisition (in real time):

- auscultation of cardiac tones and broncho-pulmonary sounds;
- oximetry;
- arterial blood pressure;
- electrocardiogram and heart frequency;
- phonocardiography;

- spirometry;
- image and audio of the patient, of professional quality.



Fig. 26. The remote medical visit system, prototyped for experimental validation, assembled in a small suitcase

6.2 Electrocardiograph

The electrocardiogram can be registered by the remote medical visit system up to 12 derivations and is interpretative, or automatically carries out the reading and the diagnosis of the tracing which the doctor must reaffirm.

It is possible to carry out monitoring without time limits and always in real time. This makes possible the capture of uneven heartbeats or also intermittent ones of other nature. The acquire tracing is registered and filed.

The ECG is PC-based and high resolution (HRECG), very useful to find the late potentials in the heart potentials. They are potentials of very very small amplitude (μV) at high frequencies (300 Hz typically, up to 500 hz), localized in the ST-T segment of the ECG (see figure 27), arising in people with heart diseases and having high risk of life. They are because of a delayed ventricular activation which happens in case of ischemia as a result of a disturbance of the electrical conductance of the heart and then they announce that serious heart fatal failures probably are incoming, especially arrhythmias and sustained ventricular tachycardia. Then, the early detection of late potentials allows to undertake promptly therapies able to reduce the risk of death.

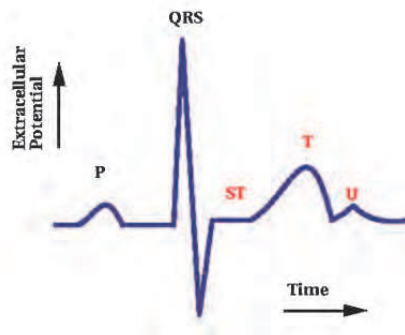

Fig. 27. Typical ECG wave period

Late potentials characteristics detected by the ECG are the following (see table 3):

Parameter	Description	Value if late potentials occur
QRSD	QRS cycle	>114 ms
RMS40	Mean value of the last 40 ms of the QRS cycle	<20 μ V
LAS40	Duration of the signal with amplitude < 40 μ V at the end of the QRS cycle	>38 ms

Table 3. Features of the ECG wave (one period) in presence of late potentials

The PC-based HRECG has been designed according to the specifications for late potentials detection: the bandwidth ranges from 0.03 hz to 500 hz due to the expected value of the maximum frequency of late potentials; the ADC resolution is 24 bit due to the very very small amplitude of late potentials. The connection with PC is possible as via USB as via Bluetooth.

The device has an hardware part and a software part (the driver of the hardware). The use of a PC allows to perform a lot of functions (i.e. filtering, real time elaboration, storage, printing, etc.) via software thus making very light the hardware part. This makes the electrocardiograph miniaturized and easy to use.

One of the most interesting functions implemented in the HRECG software is the spectral analysis of the ECG waveform (which is measured in the time domain, obviously). This analysis allows a more accurate and deep diagnosis than the only time domain analysis. In figure 28 is shown as an example the spectral analysis of the ECG of an healthy subject.

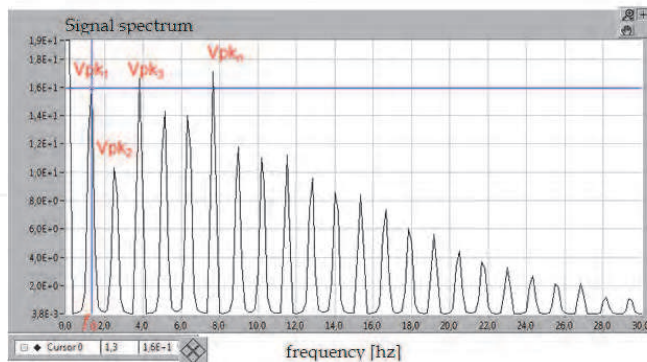

Fig. 28. Spectral analysis of the ECG of an healthy subject

Experimental results have shown us that there is a correlation between the frequencies and the amplitudes of the peaks of the ECG spectrum and cardiac diseases. These results are summarized in table 4 where:

f_0 is the fundamental frequency of the spectrum, corresponding to the hearth frequency; V_{pk_n} the amplitude of the n-th peak in the spectrum; f_{taglio} is the frequency of the harmonic which peak is 1/10 of that of the fundamental harmonic.

Pathology	Spectrum features
Tachycardia	$f_0 > 1.66 \text{ hz}$
Bradycardia	$f_0 < 1 \text{ hz}$
Ischemia	$Vpk_1 < Vpk_2$ and $Vpk_3 < Vpk_2$
Miocardial infarction	$Vpk_3 < Vpk_2$ and $Vpk_{n-1} / Vpk_n > 1.8$ e $Vpk_{n+1} / Vpk_n > 1.9$ in 66.7% of examined cases n=4
Left bundle branch block	$f_{taglio} / f_0 < 16.5$ in V5 and V6
Right bundle branch block	$f_{taglio} / f_0 < 16.5$ in V1 and V2

Table 4. Correspondence between spectrum features of the ECG signal and cardiac pathologies

Then, the remote health monitoring system uses a very advanced electrocardiograph, that goes beyond the nowadays clinical practice.

The joint use of the electrocardiograph and of the stethoscope lets you perform also phonocardiograph.

6.3 Stethoscope

The tele-stethoscope is of electronic kind (as described in section 3) and obtains biological sounds in the 20 Hz - 2 kHz band and can be used in three modes in order to improve the cardiac and pulmonary auscultation: membrane modality, bell modality and extensive one. Moreover, it allows the 75% (seventy-five percent) abatement of the external noise. It is equipped with software for the spectrum analysis in real time and it automatically starts at the beginning of the auscultation procedure.

The positioning of the stethoscope is led by a remote doctor thanks to the full time audio/video communication and the biological sounds can be simultaneously heard either by the patient (or by an operator helping the patient in the completion of the examination) or by the doctor in remote.

The biological sounds are also registered during the acquisition with significant advantages in accuracy terms of the diagnosis and possibility of carrying out diagnostic comparisons in the course of time.

The technical specifications for audio acquisition and transmission are the following:

Audio band from about 0 Hz to 4 KHz

Sampling frequency (transmission) 16 KHz

A/V Codec 16 KHz; H323-based

Sampling frequency (record) 8 KHz

6.4 Oximeter and spirometer

The tele-spirometer is of USB kind and it allows to carry out the FVC, VC, MVV tests and to determine the respiratory frequency and is autodiagnostic. The system is compatible with any commercial USB or Bluetooth spirometer.

The finger (optic) tele-saturimeter allows to carry out the monitoring of the SpO_2 value as it is equipped with plug-in which permits the tracing of a curve of blood oxygen saturation and of heart frequency values in time function, the curve will be knowledgeable in real time and visualized by the practitioner. The PC-based spirometer is often equipped with the saturimeter.

6.5 Arterial pressure measurement

The arterial pressure measurement is performed by a PC-based sphygmomanometer which consists of a classical cuff with a pump and having a valve for inflating and deflating the cuff, as shown in figure 29.



Fig. 29. Prototype of the arterial pressure measurement instrument, PC-based and wi fi connected to PC

The measure is performed by a stethoscope placed under the cuff that hear the Korotkov sounds. The instrument is connected to a PC by a wireless short distance connection. A software properly developed calculates the min and max values of arterial pressure. These values are sent real time to the remote practitioner and are stored on the patient's station. Alternatively, the instruments based on the oscillometric method can be plugged-in to the system. The PC connectivity is in this case via bluetooth or via USB interface.

6.6 Other capabilities

The filing of the data concerning the carried out examination occurs in a dynamic data base both on the patient post and the doctor post; the data will be filed by ordering them for each patient.

Thus to each patient a clinical record will be associated with all the reports as regards him. This kind of filing is very useful to carry out diagnostic comparisons on the evolution of a disease or on the outcome of a therapy, and it eases him of the burden of having the record documentation regarding him personally. In the patient data base there is also a filed schedule containing the personal details of the patient, the case history in addition to various notes, values of blood tests, the outcome of other diagnostic tests, treatments undertaken during the time, therapy in course, etc.

The system also makes possible the transmission of echograms, X-rays radiograms/other tests in digital form to the doctor and also the filing in the patient data base.

The doctor can also prescribe other subsequent clinical tests advised and/or treatments to undertake and he can subscribe with electronic signature using a smart card.

The patient data can be transferred by RFID smart card, as described in section 5.

The system doesn't present connectivity limits of any kind find and requires a 320 Kb/s minimum band or a UMTS mobile telephone is able to allow the execution of a medical examination.

The system has a user-friendly software interface of very simple employment, which implements the one touch philosophy, and requires extremely reduced operating costs. In figure 30 a draft is shown of the interface, by the patient side (part "a") and by the doctor side (part "b").

The patient can ask for a medical examination and the doctor can accept or refuse to examine him under the availability of the moment. As a result of the doctor's availability the medical examination can start and the doctor can ask for the necessary tests through a simple "click".

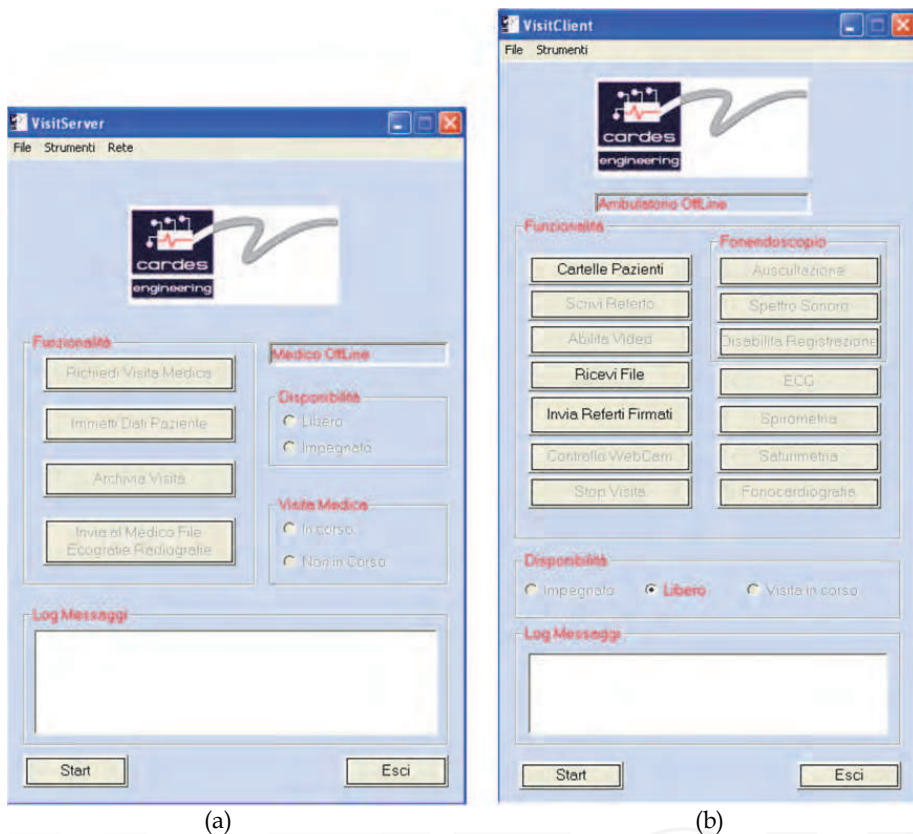

Fig. 30. Software interface: patient side (a) and doctor side (b)

The system has been planned/ designed in the observance of the current regulations in the order of medical devices and of computer security and privacy:

Audio-Video Communication: AES - 256 bit (Advanced Encryption Standard)

Login and password for user ID

Data acquired unchangeable

Asynchronous transmission: SSL connection

Virtual LAN: AES - 256 C-B-C in Tx; 96-bit version of HMAC - SHA1 for user ID

Possible implementation of the electronic signature.

It is possible to conclude that the system is marked by three distinct and basic fundamental characteristics:

1. the transmission of data in real time, by assuring the remote doctor the simultaneous control of the data at the acquisition of the same ones;

2. the possibility to carry out a complete telematic medical examination, including the teleauscultation, or all the operations the doctor performs when he examines the patient directly at home or at the surgery and even more as the system is equipped with typically diagnostic instruments not available at the family doctor's but at hospital units;
3. the possibility to establish a continuous audio/video communication during the examination, in order that the same doctor can intervene with the patient, verify the correct positioning of the sensors and of the tele-stethoscope and he can also have a very high quality image of the patient, image of ten useful for diagnostic aims.

Among the most evident and important applications we can indicate the following ones:

- home teleassistance of cardiac patients in decompensation or of chronic sufferers with pathologies attributed to the cardio-circulatory or respiratory apparatus;
- mass prophylaxis with complete cardio-respiratory control which is frequent and at low cost;
- teleconsultation;
- follow-up of patients discharged early (precociously) and in need of teleprotection;
- closed-circuit monitoring of the health of patients waiting for hospitalization.
- opportunity of a complete cardio-respiratory check up in real time at home (much more complete than a classic visit at home or at surgery) but also at a chemist's or in other equipped centres of services;
- To cut down the number of calls to emergency services (118, first aid, etc.) and the number or/and the times of admission to hospital;
- To carry out specialistic check up frequently and at low cost;
- To give the prescription of the suggested therapy or of the possible further specialistic suggested examinations at the visit result;
- To have (get) mass prevention not only at cardiac level but also at respiratory one.

7. Conclusions

In this chapter 5 examples of innovative telemedicine devices have been described.

First of all, the remote health monitoring system has been described, which is patented and each its part has been designed, prototyped and successfully tested. Currently a process of design optimization is in progress; the next step is the validation and system certification. The system is useful especially to improve the quality of life of patients who require continuous monitoring in order to prevent sudden serious damages without long stays in hospital. The system is wearable and allows the patient to be free to move.

Secondly, the internet tele-stethoscope, able to objectify and to send biological sounds in real-time via web, has been described. It seems to be of great interest both to improve the diagnostic potential of one of the most simple, fast, and completely devoid of drawbacks medical examination such auscultation, and for telemedicine applications that now seems a fixed course for reducing healthcare costs and improve quality of life of chronically ill patients through the implementation of treatment protocols in home care. The device is also very useful for monitoring patients during therapy and to evaluate through accurate comparisons of auscultation reports the evolution of a disease. This type of monitoring, being objective, is to be shared with other doctors. For the academic point of view, the internet tele-stethoscope could be a great training tool.

Third, the pain button and the Wi-Fi pain button (PB/WiPB) have been described. They are a sort of electronic caregiver very useful to allow a prompt rescue in case of illness. The best of the well known GPS, internet and wireless transmission technologies are employed in the design of these devices. The interpretative algorithm implemented on board, able to detect in real time cardiac diseases, makes the PB/WiPB more than a warning source when the disease has occurred because incoming pathologies are promptly detected thus appearing very useful to prevent damages.

Fourth, the RFID based system for automatic identification of a patient and his clinical history has been described: the requirements to which the system meets, therefore the benefits and innovations from it, range from simple procedures streamlining for acquisition of individual's clinical data, to the access to all clinical/history data for patients unable to exhibit them (because they are unconscious, or because don't remember, etc.), the automatic creation of a data base in compliance with health service computerization requirements. Moreover, the system allows a drastic reduction in recognition time and the immediate availability of patients' generic and clinical data. In a urgency situation, the immediate availability of the subject's medical history provides the choice of an effective and especially timely cure.

Finally, the remote medical visits system has been described: the system is patent pending. The system aims at offering home care services for chronic patients or people afflicted with pathologies (for example, some forms of cardiac decompensation or chronic obstructive bronchopathy) for which the domestic monitoring can quietly avoid the admission to hospital with significant advantages in terms of quality of the patient's life and of cutting down the sanitary expenses. The described system allows to carry out remote complete medical examinations, or rather with a doctor placed in another place as to the patient but able to effect a check-up more complete and precise than that one effected with the current available means if the doctor goes the patient's house or even if he examines the patient at his own surgery. Then, the system could permit a significant saving of the health care expenses and an improvement of the quality of chronic patient's life by offering them frequent and easy check-up in the privacy of the home and by avoiding expensive hospitalization.

Among the developments of the system we expect the use of pocket PC (palmar) as base element of the doctor station.

The reduction of hospitalization time, because of home teleprotection, and the possibility to avoid the hospitalization of patients in decompensation monitored from home imply an economic assured saving.

It is also manifest that we can reduce the waiting lists in a remarkable way.

By the applications described it results that wireless transmission technology, at short or long distance, is the best way to realize a remote patient control. It results that it is necessary to transmit, beyond patient health status data, also video and audio signal to have a complete patient diagnose and a mean for a human interaction between the doctor and the patient. So the amount of the information to be transmitted is more and more high. This move the development of telemedicine systems towards those technology, like Wi-Fi and Wimax, that assure more bandwidth.

Telemedicine systems can severely reduce health certificate expense, but to do this it is necessary a centralized monitoring system, based on a database engine to which each

hospital can connect and download the information. In such a way the patient is free to move away from hospital and even from his home. In fact, the trend of this system is to use GPS to track patient's position.

We conclude by saying that the success of those systems also depends on their wearability: if it is small enough the patient wears it. So the biggest challenge is to integrate more and more the dimension of microcontroller and sensors embedded.

8. References

- [1] Aoyagi, T., Kishi, M., Yamaguchi, K., Watanabe, S., (1974), Improvement of the earpiece oximeter, *Proceedings of 13-th Annual Meeting of the Japan Society of Medical Electronic and Biological Engineering*, Osaka, April, 1974, pp. 90–91.
- [2] Caduff, A., Hirt, E., Feldman, Y., Ali, Z. & Heinemann, L., (2003) First human experiments with a novel non-invasive, non-optical continuous glucose monitoring system, *Journal of Biosensors and Bioelectronics*, Vol. 19, issue 3, pp. 209-217, ISSN: 0956 – 5663
- [3] Carr, J. J. & Brown J. M., (2001). *Introduction to biomedical equipment technology*, 4/E, Prentice Hall, ISBN: 0-13-010492-2, Upper Saddle River - New Jersey.
- [4] Dower, G. E., Yakush, A., Nazzal, S. B., Jutzi, R. V. & Ruiz, C. E., (1988). Deriving the 12-lead Electrocardiogram from four (EASI) electrodes. *Journal of Electrocardiology*, Vol. 21, supplement 1, pp. S182- S187, ISSN 0022-0736
- [5] Evans, T., (1998), Cardiac Arrests Outside Hospital, *British Medical Journal*, Vol. 316, No. 7137, (1998), pp. 1031-1032, ISSN: 0959-8138
- [6] Giorgio, A. (2008). Sistema per visite mediche in remoto, *Italian Patent Pending N. BA2008A000054*
- [7] Giorgio, A. (2009). Sistema Universale di Monitoraggio delle Attività Vitali Umane e Dispositivi Dedicati, *Italian Patent N. 0001354840*
- [8] Hayashi, Y., Livshits, L., Caduff, A. & Feldman, Y., (2003) Dielectric spectroscopy study of specific glucose influence on human erythrocyte membranes, *Journal of Physics D: Applied Physics*, Vol. 36, N. 4., pp. 369-375, ISSN: 022 – 3727
- [9] Jingping, X., Cheng, J. & Yanjun, W., (1998), A Cepstral Method for Analysis of Acoustic Transmission Characteristics of Respiratory System. *IEEE Transactions On Biomedical Engineering*, Vol. 45, No. 5, (May 1998), pp. 660-663, ISSN: 0018-9294
- [10] Paris, D., Mastrorocostas, A., Tolia, Y. A., Theocharis, J. B., Hadjilentiadis, L. J. & Panas, S. M., (2000), An Orthogonal Least Squares-Based Fuzzy Filter for Real-Time Analysis of Lung Sounds, *IEEE Transactions On Biomedical Engineering*, Vol. 47, No. 9, (September 2000), pp. 1165-1176, ISSN: 0018-9294
- [11] Rossi Mori A., Ricci, F. & Maceratini, R., (March 2001). *Il Medico on Line: Manuale di informatica medica*. Verduci editore, ISBN: 9788876205750.
- [12] Yang-Sheng Lu, Wen-Hui Liu & Guang-Xia Quin, (1988). Removal of The Heart Sound Noise From The Breath Sound. *Proceedings of the 10-th Annual International Conference of the IEEE Engineering In Medicine And Biology Society*, ISBN 0-7803-0785-2, New Orleans, LA, USA, November 1988, pp. 175-176.

- [13] Webster, J. G., ed., (2009) *Medical instrumentation, Application and design*, J. Wiley, ISBN: 978-0-471-67600-3

INTECH

INTECH

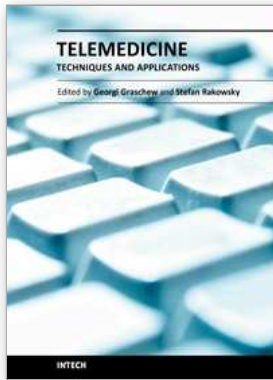

Telemedicine Techniques and Applications

Edited by Prof. Georgi Graschew

ISBN 978-953-307-354-5

Hard cover, 514 pages

Publisher InTech

Published online 20, June, 2011

Published in print edition June, 2011

Telemedicine is a rapidly evolving field as new technologies are implemented for example for the development of wireless sensors, quality data transmission. Using the Internet applications such as counseling, clinical consultation support and home care monitoring and management are more and more realized, which improves access to high level medical care in underserved areas. The 23 chapters of this book present manifold examples of telemedicine treating both theoretical and practical foundations and application scenarios.

How to reference

In order to correctly reference this scholarly work, feel free to copy and paste the following:

Agostino Giorgio (2011). Innovative Medical Devices for Telemedicine Applications, Telemedicine Techniques and Applications, Prof. Georgi Graschew (Ed.), ISBN: 978-953-307-354-5, InTech, Available from: <http://www.intechopen.com/books/telemedicine-techniques-and-applications/innovative-medical-devices-for-telemedicine-applications>

INTECH
open science | open minds

InTech Europe

University Campus STeP Ri
Slavka Krautzeka 83/A
51000 Rijeka, Croatia
Phone: +385 (51) 770 447
Fax: +385 (51) 686 166
www.intechopen.com

InTech China

Unit 405, Office Block, Hotel Equatorial Shanghai
No.65, Yan An Road (West), Shanghai, 200040, China
中国上海市延安西路65号上海国际贵都大饭店办公楼405单元
Phone: +86-21-62489820
Fax: +86-21-62489821